



# target | T2S services

Target2-Securities

User Handbook

R2025.JUN

13 March 2025

---

# Table of Contents

|   |           |
|---|-----------|
| <b>Index.....</b>   | <b>19</b> |
| <b>Disclaimer.....</b>  | <b>21</b> |
| <b>Terms and Abbreviations.....</b>                                   | <b>22</b> |
| <b>1 Introduction.....</b>  | <b>25</b> |
| <b>1.1 Overview of the User Handbook.....</b>                         | <b>25</b> |
| <b>1.1.1 UHB Methodology.....</b>                                     | <b>25</b> |
| <b>1.1.2 UHB Structure.....</b>                                       | <b>28</b> |
| <b>1.2 Overview of the Graphical User Interface for T2S GUI.....</b>  | <b>30</b> |
| <b>1.2.1 Setup and Login Procedures.....</b>                          | <b>30</b> |
| <b>1.2.2 GUI Structure.....</b>                                       | <b>31</b> |
| 1.2.2.1 Menu Structure.....   | 31        |
| 1.2.2.2 Screen Structure.....   | 32        |
| 1.2.2.3 Screen Types.....   | 34        |
| 1.2.2.4 Field Types and Properties.....                               | 36        |
| 1.2.2.5 Common Buttons and Icons.....                                 | 42        |
| <b>1.2.3 Validation.....</b>  | <b>48</b> |
| <b>1.2.4 Communication Network and Services.....</b>                  | <b>53</b> |
| <b>1.2.5 User Administration.....</b>                                 | <b>53</b> |
| <b>1.2.6 Security and Certification Service.....</b>                  | <b>53</b> |
| <b>1.2.7 Online Help.....</b>   | <b>53</b> |
| <b>1.3 Overview of the Graphical User Interface for CoCo GUI.....</b> | <b>54</b> |
| <b>1.3.1 Setup and Login Procedures.....</b>                          | <b>55</b> |
| <b>1.3.2 GUI Structure.....</b>                                       | <b>56</b> |
| 1.3.2.1 Menu Structure.....   | 57        |
| 1.3.2.2 Screen Structure.....   | 57        |
| 1.3.2.3 Screen Types.....   | 59        |
| 1.3.2.4 Field Types and Properties.....                               | 60        |
| 1.3.2.5 Common Buttons and Icons.....                                 | 67        |
| <b>1.3.3 Validation.....</b>  | <b>72</b> |
| <b>1.3.4 Communication Network and Services.....</b>                  | <b>74</b> |
| <b>1.3.5 User Administration.....</b>                                 | <b>74</b> |
| <b>1.3.6 Security and Certification Services.....</b>                 | <b>75</b> |
| <b>1.3.7 Online Help.....</b>   | <b>75</b> |
| <b>2 Screen Reference Part.....</b>                                   | <b>76</b> |
| <b>2.1 General.....</b>   | <b>76</b> |
| <b>2.2 Securities.....</b>  | <b>81</b> |
| <b>2.2.1 Securities Account.....</b>                                  | <b>81</b> |

|              |  |            |
|--------------|--|------------|
| 2.2.1.1      | Securities Positions - Search/List Screen.....   | 81         |
| 2.2.1.2      | Securities Position - Details Screen .....   | 81         |
| 2.2.1.3      | Securities Postings - Search/List Screen .....   | 81         |
| 2.2.1.4      | Securities Restriction Details - Search/List Screen .....                                  | 85         |
| <b>2.2.2</b> | <b>Settlement.....</b>   | <b>89</b>  |
| 2.2.2.1      | Allegement Instructions - Search/List Screen.....  | 89         |
| 2.2.2.2      | Allegement Instruction - Details Screen .....  | 93         |
| 2.2.2.3      | Amendment Securities Instruction - Details Screen .....                                    | 97         |
| 2.2.2.4      | Amendment Securities Instruction - New Screen .....  | 102        |
| 2.2.2.5      | Cancellation Securities Instruction - Details Screen.....                                  | 112        |
| 2.2.2.6      | Cancellation Securities Instruction - New Screen.....                                      | 116        |
| 2.2.2.7      | Data Changes - Search/List Screen .....  | 121        |
| 2.2.2.8      | Data Change - Details Screen.....  | 121        |
| 2.2.2.9      | Hold/Release Instruction - Details Screen.....   | 121        |
| 2.2.2.10     | Hold/Release Instruction - New Screen.....   | 125        |
| 2.2.2.11     | Intra-Position Movements - Search/List Screen .....  | 136        |
| 2.2.2.12     | Intra-Position Movement - Details Screen .....   | 143        |
| 2.2.2.13     | Intra-Position Movement - New Screen.....  | 150        |
| 2.2.2.14     | Maintenance Securities Instructions - Search/List Screen .....                             | 163        |
| 2.2.2.15     | Securities Positions - Search/List Screen.....   | 168        |
| 2.2.2.16     | Securities Position - Details Screen .....   | 173        |
| 2.2.2.17     | Settlement Instructions - Search/List Screen .....   | 176        |
| 2.2.2.18     | Settlement Instruction - Details Screen .....  | 191        |
| 2.2.2.19     | Settlement Instruction - New Screen .....  | 210        |
| 2.2.2.20     | Status History - Details Screen.....   | 266        |
| 2.2.2.21     | Insolvency procedure Settlement Instructions - Search/List Screen<br>.....                 | 269        |
| 2.2.2.22     | Links Preventing Settlement - List Screen.....   | 276        |
| 2.2.2.23     | Penalty - Search/List Screen .....   | 278        |
| 2.2.2.24     | Penalty - Details Screen .....   | 290        |
| 2.2.2.25     | Monthly Net Penalty Amounts - Search/List Screen.....                                      | 309        |
| 2.2.2.26     | Penalty - Removal Screen.....  | 314        |
| 2.2.2.27     | Penalty - Re-allocation Screen .....   | 317        |
| 2.2.2.28     | Penalty - Switch Screen .....  | 321        |
| <b>2.3</b>   | <b>Cash .....</b>  | <b>323</b> |
| <b>2.3.1</b> | <b>Cash Account.....</b>   | <b>323</b> |
| 2.3.1.1      | Cash Forecasts - Search/List Screen.....   | 323        |
| 2.3.1.2      | Cash Forecast - Details Screen.....  | 331        |
| 2.3.1.3      | Cash Restriction Details - Search/List Screen.....   | 337        |
| 2.3.1.4      | Collateral Values of a Security - Search/List Screen .....                                 | 340        |
| 2.3.1.5      | Collateral Values per T2S Dedicated Cash Account and Security -<br>Search/List Screen..... | 344        |

---

|              |  |            |
|--------------|--|------------|
| 2.3.1.6      | Limits - Search/list Screen .....  | 347        |
| 2.3.1.7      | Limit - New/Edit Screen .....  | 347        |
| 2.3.1.8      | Limit Utilisation - Search/List Screen .....   | 348        |
| 2.3.1.9      | Limit Utilisation Journal - Search/List Screen .....                                       | 352        |
| 2.3.1.10     | T2S DCA Balances - Search/List Screen .....  | 357        |
| 2.3.1.11     | T2S DCA Balance - Details Screen .....   | 361        |
| 2.3.1.12     | T2S DCA Postings - Search/List Screen .....  | 363        |
| 2.3.1.13     | Total Collateral Values per T2S Dedicated Cash Account - Search/<br>List Screen .....      | 369        |
| <b>2.3.2</b> | <b>Liquidity .....</b>   | <b>373</b> |
| 2.3.2.1      | Data Changes - Search/List Screen .....  | 373        |
| 2.3.2.2      | Data Change - Details Screen .....   | 373        |
| 2.3.2.3      | Immediate Liquidity Transfers - Search/List Screen .....                                   | 373        |
| 2.3.2.4      | Immediate Liquidity Transfer - Details Screen.....   | 381        |
| 2.3.2.5      | Immediate Liquidity Transfer - New Screen .....  | 386        |
| 2.3.2.6      | Outstanding Auto-Collateralisation Credits - Search/List Screen ..                         | 392        |
| 2.3.2.7      | Overall Liquidity - Search/List Screen .....   | 396        |
| 2.3.2.8      | Standing/Predefined Liquidity Transfer Orders - Search/List Screen<br>.....                | 400        |
| 2.3.2.9      | Standing/Predefined Liquidity Transfer Order - Details Screen.....                         | 400        |
| 2.3.2.10     | Standing/Predefined Liquidity Transfer Order - New/Edit Screen .                           | 400        |
| 2.3.2.11     | Standing/Predefined Liquidity Transfer Order Link Sets - Search/List<br>Screen .....       | 400        |
| 2.3.2.12     | Standing/Predefined Liquidity Transfer Order Link Set - Details<br>Screen .....            | 400        |
| 2.3.2.13     | Standing/Predefined Liquidity Transfer Order Link Set - New/Edit<br>Screen .....           | 400        |
| 2.3.2.14     | Total Amount of Standing/Predefined Liquidity Transfer Orders -<br>Search/List Screen..... | 400        |
| <b>2.3.3</b> | <b>Settlement.....</b>   | <b>404</b> |
| 2.3.3.1      | Amendment Cash Instruction - Details Screen.....   | 404        |
| 2.3.3.2      | Amendment Cash Instruction - New Screen .....  | 409        |
| 2.3.3.3      | Cancellation Cash Instruction - Details Screen .....                                       | 416        |
| 2.3.3.4      | Cancellation Cash Instruction - New Screen .....   | 419        |
| 2.3.3.5      | Intra-Balance Movements - Search/List Screen .....   | 422        |
| 2.3.3.6      | Intra-Balance Movement - Details Screen.....   | 429        |
| 2.3.3.7      | Intra-Balance Movement - New Screen.....   | 436        |
| 2.3.3.8      | Maintenance Cash Instructions - Search/List Screen.....                                    | 447        |
| 2.3.3.9      | Status History - Details Screen.....   | 451        |
| <b>2.4</b>   | <b>Services .....</b>  | <b>451</b> |
| <b>2.4.1</b> | <b>Additional Services.....</b>  | <b>451</b> |
| 2.4.1.1      | Available Reports - Search/List Screen .....   | 451        |

---

---

|          |  |     |
|----------|--|-----|
| 2.4.1.2  | Available Report - Details Screen.....   | 456 |
| 2.4.1.3  | Available Report - Current Settlement Day Cash Information (Following Settlement Day Cash Forecast) Report - Details Screen..                      | 458 |
| 2.4.1.4  | Available Report - Statement of Accounts - Details Screen .....  | 463 |
| 2.4.1.5  | Available Report - Statement of Executed Amendment Instructions for Intra-Balance Movements - Details Screen .....                                 | 466 |
| 2.4.1.6  | Available Report - Statement of Executed Amendment Instructions for Intra-Position Movements and Settlement Instructions - Details Screen .....    | 471 |
| 2.4.1.7  | Available Report - Statement of Executed Cancellation Instructions for Intra-Balance Movements - Details Screen .....                              | 480 |
| 2.4.1.8  | Available Report - Statement of Executed Cancellation Instructions for Intra-Position Movements and Settlement Instructions - Details Screen ..... | 484 |
| 2.4.1.9  | Available Report - Statement of Holdings - Details Screen .....  | 492 |
| 2.4.1.10 | Available Report - Statement of Pending Amendment Instructions for Intra-Balance Movements - Details Screen.....                                   | 497 |
| 2.4.1.11 | Available Report - Statement of Pending Amendment Instructions for Intra-Position Movements and Settlement Instructions - Details Screen.....      | 502 |
| 2.4.1.12 | Available Report - Statement of Pending Cancellation Instructions for Intra-Balance Movements - Details Screen.....                                | 511 |
| 2.4.1.13 | Available Report - Statement of Pending Cancellation Instructions for Intra-Position Movements and Settlement Instructions - Details Screen.....   | 515 |
| 2.4.1.14 | Available Report - Statement of Pending Instructions - Details Screen .....  | 523 |
| 2.4.1.15 | Available Report - Statement of Pending Intra-Balance Movements - Details Screen.....  | 532 |
| 2.4.1.16 | Available Report - Statement of Pending Intra-Position Movements - Details Screen.....   | 537 |
| 2.4.1.17 | Available Report - Statement of Settled Intra-Balance Movements - Details Screen.....  | 542 |
| 2.4.1.18 | Available Report - Statement of Settled Intra-Position Movements - Details Screen.....   | 547 |
| 2.4.1.19 | Available Report - Statement of Settlement Allegements - Details Screen.....   | 550 |
| 2.4.1.20 | Available Report - Statement of Transactions - Details Screen ....   | 563 |
| 2.4.1.21 | Available Report – Daily Penalty List – Details Screen .....   | 573 |
| 2.4.1.22 | Available Report – List of Modified Penalties - Details Screen.....  | 587 |
| 2.4.1.23 | Available Report – Monthly Aggregated Amounts – Details Screen .....   | 602 |

---

|              |   |            |
|--------------|---|------------|
| 2.4.1.24     | Data Changes - Search/List Screen .....                           | 607        |
| 2.4.1.25     | Data Change - Details Screen .....                                | 611        |
| <b>2.4.2</b> | <b>Communication .....</b>  | <b>616</b> |
| 2.4.2.1      | Broadcast - Search/List Screen .....                              | 616        |
| 2.4.2.2      | Broadcast - Details Screen .....                                  | 619        |
| 2.4.2.3      | Broadcast - New Screen .....                                      | 621        |
| 2.4.2.4      | Inbound Files - Search/List Screen .....                          | 622        |
| 2.4.2.5      | Inbound File - Details Screen .....                               | 625        |
| 2.4.2.6      | Inbound Messages - Search/List Screen .....                       | 628        |
| 2.4.2.7      | Inbound Message - Details Screen .....                            | 635        |
| 2.4.2.8      | Outbound Files - Search/List Screen .....                         | 640        |
| 2.4.2.9      | Outbound File - Details Screen .....                              | 643        |
| 2.4.2.10     | Outbound Messages - Search/List Screen .....                      | 645        |
| 2.4.2.11     | Outbound Message - Details Screen .....                           | 653        |
| 2.4.2.12     | Resend Communication Screen .....                                 | 657        |
| <b>2.4.3</b> | <b>Revisions .....</b>  | <b>661</b> |
| 2.4.3.1      | Revisions/Audit Trail - List Screen .....                         | 661        |
| <b>2.5</b>   | <b>Monitoring .....</b>   | <b>662</b> |
| <b>2.5.1</b> | <b>Monitoring .....</b>   | <b>662</b> |
| 2.5.1.1      | Securities Positions - Search/List Screen .....                   | 662        |
| 2.5.1.2      | Securities Position - Details Screen .....                        | 662        |
| 2.5.1.3      | T2S DCA Balances - Search/List Screen .....                       | 663        |
| 2.5.1.4      | T2S DCA Balance - Details Screen .....                            | 663        |
| <b>3</b>     | <b>User Instructions Part .....</b>                               | <b>664</b> |
| <b>3.1</b>   | <b>General .....</b>  | <b>664</b> |
| <b>3.2</b>   | <b>Communication .....</b>  | <b>665</b> |
| <b>3.2.1</b> | <b>Usage of Broadcasts .....</b>                                  | <b>665</b> |
| 3.2.1.1      | Create a New Broadcast .....                                      | 665        |
| 3.2.1.2      | View a Broadcast .....  | 666        |
| <b>3.2.2</b> | <b>Monitoring of Communication .....</b>                          | <b>667</b> |
| 3.2.2.1      | Resend Communication .....  | 667        |
| 3.2.2.2      | View Inbound Communication .....                                  | 668        |
| 3.2.2.3      | View Outbound Communication .....                                 | 669        |
| <b>3.3</b>   | <b>Liquidity Transfers .....</b>                                  | <b>671</b> |
| <b>3.3.1</b> | <b>Creation of a New Immediate Liquidity Transfer Order .....</b> | <b>671</b> |
| 3.3.1.1      | Copy an Immediate Liquidity Transfer Order .....                  | 671        |
| <b>3.4</b>   | <b>Cash and Settlement Monitoring .....</b>                       | <b>673</b> |
| <b>3.4.1</b> | <b>Monitoring of Cash, Collateral and Limits Situation .....</b>  | <b>673</b> |
| 3.4.1.1      | View Cash Balances Details and Related Postings .....             | 673        |
| 3.4.1.2      | View Cash Balances Details and Related Restrictions .....         | 674        |

---

|              |  |            |
|--------------|--|------------|
| 3.4.1.3      | View Immediate Liquidity Transfer Order Details .....  | 675        |
| 3.4.1.4      | View Overall Liquidity .....   | 677        |
| 3.4.1.5      | Reimburse an Outstanding Intraday Credit .....   | 679        |
| <b>3.4.2</b> | <b>Monitoring of Securities Positions.....</b>   | <b>680</b> |
| 3.4.2.1      | View Current Securities Positions and Related Postings .....                                 | 681        |
| 3.4.2.2      | View Current Securities Positions and Related Restrictions .....                             | 682        |
| 3.4.2.3      | View Historic Securities Positions for a Specific Date .....                                 | 683        |
| 3.4.2.4      | View Historic Securities Positions for a Specific Period .....                               | 684        |
| <b>3.5</b>   | <b>Settlement Instructions .....</b>   | <b>685</b> |
| <b>3.5.1</b> | <b>Creation of a New Settlement Instruction.....</b>   | <b>685</b> |
| 3.5.1.1      | Enter a Settlement Instruction .....   | 686        |
| 3.5.1.2      | Copy a Settlement Instruction .....  | 690        |
| 3.5.1.3      | Respond to an Allegement Instruction.....  | 696        |
| 3.5.1.4      | View Settlement Instruction Details .....  | 701        |
| 3.5.1.5      | View Allegement Settlement Instruction Details .....   | 702        |
| <b>3.5.2</b> | <b>Creation of a New Amendment Instruction for a Settlement Instruction</b><br>.....         | <b>703</b> |
| 3.5.2.1      | Add a Link for a Settlement Instruction.....   | 703        |
| 3.5.2.2      | Amend the Partial Settlement Indicator for a Settlement Instruction<br>.....                 | 706        |
| 3.5.2.3      | Amend the Priority for a Settlement Instruction .....  | 707        |
| 3.5.2.4      | Remove a Link for a Settlement Instruction.....  | 709        |
| 3.5.2.5      | View Amendment Instruction for a Settlement Instruction Details.                             | 711        |
| <b>3.5.3</b> | <b>Creation of a New Hold/Release Instruction for a Settlement Instruction</b><br>.....      | <b>713</b> |
| 3.5.3.1      | Put a Settlement Instruction on Party Hold.....  | 713        |
| 3.5.3.2      | Put a Settlement Instruction on CSD Hold .....   | 715        |
| 3.5.3.3      | Release a Settlement Instruction from Party Hold.....  | 717        |
| 3.5.3.4      | Partially Release a Settlement Instruction from Party Hold .....                             | 718        |
| 3.5.3.5      | Release a Settlement Instruction from CSD Hold .....   | 720        |
| 3.5.3.6      | Release a Settlement Instruction from CoSD Hold .....  | 722        |
| 3.5.3.7      | Release a Settlement Instruction from CSD Validation Hold.....                               | 724        |
| 3.5.3.8      | View Hold/Release Instruction Details.....   | 725        |
| <b>3.5.4</b> | <b>Creation of a New Cancellation Instruction for a Settlement Instruction</b><br>.....      | <b>727</b> |
| 3.5.4.1      | Cancel a Settlement Instruction.....   | 727        |
| 3.5.4.2      | View Cancellation Instruction for a Settlement Instruction Details                           | 729        |
| 3.5.4.3      | View Alleged Cancellation Instructions.....  | 730        |
| <b>3.5.5</b> | <b>Monitoring of the Lifecycle of a Settlement Instruction .....</b>                         | <b>732</b> |
| 3.5.5.1      | View Settlement Instruction Status History.....  | 732        |
| 3.5.5.2      | View SF1/SF2 timestamps of Settlement Instructions in case of In-<br>solvency situation..... | 733        |

---

|              |  |            |
|--------------|--|------------|
| <b>3.5.6</b> | <b>View the list of links data preventing settlement of a settlement instruction .....</b>               | <b>734</b> |
| <b>3.5.7</b> | <b>Monitoring of Penalties .....</b>   | <b>735</b> |
| 3.5.7.1      | View the Individual Penalty Details.....   | 735        |
| 3.5.7.2      | Modification of existing penalties .....   | 737        |
| 3.5.7.3      | View List of Penalties .....   | 742        |
| 3.5.7.4      | View monthly aggregated net amounts of penalties.....  | 743        |
| <b>3.6</b>   | <b>Settlement Restrictions .....</b>   | <b>745</b> |
| <b>3.6.1</b> | <b>Creation of a New Settlement Restriction on Securities .....</b>                                      | <b>745</b> |
| 3.6.1.1      | Enter a Settlement Restriction on Securities .....   | 745        |
| 3.6.1.2      | Copy a Settlement Restriction on Securities .....  | 747        |
| 3.6.1.3      | View Settlement Restriction on Securities Details.....   | 750        |
| <b>3.6.2</b> | <b>Creation of a New Settlement Restriction on Cash .....</b>  | <b>751</b> |
| 3.6.2.1      | Enter a Settlement Restriction on Cash .....   | 751        |
| 3.6.2.2      | Copy a Settlement Restriction on Cash.....   | 753        |
| 3.6.2.3      | View Settlement Restriction on Cash Details .....  | 756        |
| <b>3.6.3</b> | <b>Creation of a New Amendment Instruction for a Settlement Restriction on Securities .....</b>          | <b>757</b> |
| 3.6.3.1      | Add a Link for a Settlement Restriction on Securities .....  | 757        |
| 3.6.3.2      | Amend the Priority for a Settlement Restriction on Securities.....                                       | 760        |
| 3.6.3.3      | Remove a Link for a Settlement Restriction on Securities .....   | 762        |
| 3.6.3.4      | View Amendment Instruction for a Settlement Restriction on Securities Details.....                       | 764        |
| <b>3.6.4</b> | <b>Creation of a New Amendment Instruction for a Settlement Restriction on Cash.....</b>                 | <b>765</b> |
| 3.6.4.1      | Add a Link for a Settlement Restriction on Cash.....   | 766        |
| 3.6.4.2      | Amend the Priority for a Settlement Restriction on Cash .....  | 768        |
| 3.6.4.3      | Remove a Link for a Settlement Restriction on Cash.....  | 770        |
| 3.6.4.4      | View Amendment Instruction for a Settlement Restriction on Cash Details .....                            | 772        |
| <b>3.6.5</b> | <b>Creation of a New Cancellation Instruction for a Settlement Restriction on Securities .....</b>       | <b>773</b> |
| 3.6.5.1      | Cancel a Settlement Restriction on Securities .....  | 773        |
| 3.6.5.2      | View Cancellation Instruction for a Settlement Restriction on Securities Details.....                    | 775        |
| <b>3.6.6</b> | <b>Creation of a New Cancellation Instruction for a Settlement Restriction on Cash .....</b>             | <b>777</b> |
| 3.6.6.1      | Cancel a Settlement Restriction on Cash.....   | 777        |
| 3.6.6.2      | View Cancellation Instruction for a Settlement Restriction on Cash Details .....                         | 778        |
| <b>3.6.7</b> | <b>View the list of links data preventing settlement of a settlement restriction on securities .....</b> | <b>780</b> |

---



---

|         |   |     |
|---------|---|-----|
| 3.6.8   | View the list of links data preventing settlement of a settlement restriction on cash ..... | 781 |
| 4       | Trouble Management System Part .....  | 783 |
| 4.1     | General.....  | 783 |
| 4.2     | Screen Reference Part.....  | 786 |
| 4.2.1   | Trouble Case – Search/List Screen .....   | 786 |
| 4.2.2   | Trouble Case - Details Screen .....   | 792 |
| 4.2.3   | Trouble Case - Export Screen.....   | 798 |
| 4.3     | User Instructions Part.....   | 804 |
| 4.3.1   | Monitoring of a Trouble Case .....  | 804 |
| 4.3.1.1 | View Trouble Case .....   | 805 |
| 4.3.1.2 | Execute a Report.....   | 805 |
| 5       | Annex .....   | 808 |
| 5.1     | Indication of Usage .....   | 808 |
| 5.1.1   | Reader's Guide .....  | 808 |
| 5.1.2   | Usage Indication .....  | 808 |
| 5.2     | Sitemap for T2S GUI .....   | 820 |
| 5.2.1   | Reader's Guide.....   | 820 |
| 5.2.2   | Securities .....  | 824 |
| 5.2.2.1 | Securities Account.....   | 824 |
| 5.2.2.2 | Settlement .....  | 825 |
| 5.2.2.3 | Settlement II .....   | 826 |
| 5.2.3   | Cash .....  | 827 |
| 5.2.3.1 | Cash Account .....  | 827 |
| 5.2.3.2 | Liquidity .....   | 828 |
| 5.2.3.3 | Liquidity II .....  | 829 |
| 5.2.3.4 | Settlement .....  | 830 |
| 5.2.4   | Services .....  | 831 |
| 5.2.4.1 | Additional Services .....   | 831 |
| 5.2.4.2 | Additional Services II .....  | 832 |
| 5.2.4.3 | Additional Services III .....   | 833 |
| 5.2.4.4 | Additional Services IV .....  | 834 |
| 5.2.4.5 | Additional Services V.....  | 835 |
| 5.2.4.6 | Additional Services VI.....   | 836 |
| 5.2.4.7 | Communication.....  | 837 |
| 5.2.4.8 | Communication II.....   | 838 |
| 5.2.4.9 | Communication III.....  | 839 |
| 5.2.5   | Monitoring.....   | 840 |
| 5.2.5.1 | Monitoring .....  | 840 |

---

|              |  |            |
|--------------|--|------------|
| <b>5.2.6</b> | <b>Business Day Management.....</b>  | <b>841</b> |
| 5.2.6.1      | Business Day Management.....   | 841        |
| <b>5.3</b>   | <b>List of Privileges .....</b>  | <b>842</b> |
| <b>5.3.1</b> | <b>Reader's Guide.....</b>   | <b>842</b> |
| <b>5.3.2</b> | <b>Privilege Classes for GUI Screens .....</b>   | <b>842</b> |
| <b>5.3.3</b> | <b>Privileges for T2S GUI Screens .....</b>  | <b>866</b> |
| 5.3.3.1      | Allegation Instruction - Details Screen .....  | 866        |
| 5.3.3.2      | Allegation Instructions - Search/List Screen.....  | 866        |
| 5.3.3.3      | Amendment Cash Instruction - Details Screen.....   | 866        |
| 5.3.3.4      | Amendment Cash Instruction - New Screen .....  | 867        |
| 5.3.3.5      | Amendment Securities Instruction - Details Screen .....  | 867        |
| 5.3.3.6      | Amendment Securities Instruction - New Screen .....  | 868        |
| 5.3.3.7      | Available Report - Current Settlement Day Cash Information (Following Settlement Day Cash Forecast) Report - Details Screen..                      | 868        |
| 5.3.3.8      | Available Report - Details Screen.....   | 869        |
| 5.3.3.9      | Available Report - Statement of Accounts - Details Screen .....  | 869        |
| 5.3.3.10     | Available Report - Statement of Executed Amendment Instructions for Intra-Balance Movements - Details Screen .....                                 | 869        |
| 5.3.3.11     | Available Report - Statement of Executed Amendment Instructions for Intra-Position Movements and Settlement Instructions - Details Screen .....    | 870        |
| 5.3.3.12     | Available Report - Statement of Executed Cancellation Instructions for Intra-Balance Movements - Details Screen .....                              | 870        |
| 5.3.3.13     | Available Report - Statement of Executed Cancellation Instructions for Intra-Position Movements and Settlement Instructions - Details Screen ..... | 870        |
| 5.3.3.14     | Available Report - Statement of Holdings - Details Screen .....  | 870        |
| 5.3.3.15     | Available Report - Statement of Pending Amendment Instructions for Intra-Balance Movements - Details Screen.....                                   | 871        |
| 5.3.3.16     | Available Report - Statement of Pending Amendment Instructions for Intra-Position Movements and Settlement Instructions - Details Screen.....      | 871        |
| 5.3.3.17     | Available Report - Statement of Pending Cancellation Instructions for Intra-Balance Movements - Details Screen.....                                | 871        |
| 5.3.3.18     | Available Report - Statement of Pending Cancellation Instructions for Intra-Position Movements and Settlement Instructions - Details Screen.....   | 872        |
| 5.3.3.19     | Available Report - Statement of Pending Instructions - Details Screen .....  | 872        |
| 5.3.3.20     | Available Report - Statement of Pending Intra-Balance Movements - Details Screen.....  | 872        |

|          |   |     |
|----------|---|-----|
| 5.3.3.21 | Available Report - Statement of Pending Intra-Position Movements - Details Screen ..... | 873 |
| 5.3.3.22 | Available Report - Statement of Settled Intra-Balance Movements - Details Screen .....  | 873 |
| 5.3.3.23 | Available Report - Statement of Settled Intra-Position Movements - Details Screen ..... | 873 |
| 5.3.3.24 | Available Report - Statement of Settlement Allegements - Details Screen .....           | 873 |
| 5.3.3.25 | Available Report - Statement of Transactions - Details Screen ....                      | 874 |
| 5.3.3.26 | Available Reports - Search/List Screen .....  | 874 |
| 5.3.3.27 | Available Reports – Daily Penalty List – Details Screen .....                           | 874 |
| 5.3.3.28 | Available Reports – List of Modified Penalties – Details Screen ...                     | 875 |
| 5.3.3.29 | Available Reports – Monthly Aggregated Amounts – Details Screen .....                   | 875 |
| 5.3.3.30 | Broadcast - Details Screen .....  | 875 |
| 5.3.3.31 | Broadcast - New Screen .....  | 875 |
| 5.3.3.32 | Broadcasts - Search/List Screen .....   | 876 |
| 5.3.3.33 | Calender - Details Screen .....   | 876 |
| 5.3.3.34 | Cancellation Cash Instruction - Details Screen .....                                    | 876 |
| 5.3.3.35 | Cancellation Cash Instruction - New Screen .....  | 877 |
| 5.3.3.36 | Cancellation Securities Instruction - Details Screen .....                              | 877 |
| 5.3.3.37 | Cancellation Securities Instruction - New Screen .....                                  | 877 |
| 5.3.3.38 | Cash Forecast - Details Screen .....  | 878 |
| 5.3.3.39 | Cash Forecasts - Search/List Screen .....   | 878 |
| 5.3.3.40 | Cash Restriction Details - Search/List Screen .....                                     | 878 |
| 5.3.3.41 | Collateral Value of a Security - Search/List Screen .....                               | 879 |
| 5.3.3.42 | Collateral Value per T2S Dedicated Cash Account and Security - Search/List Screen ..... | 879 |
| 5.3.3.43 | Settlement Day - Search/List Screen .....   | 879 |
| 5.3.3.44 | Data Change - Details Screen .....  | 880 |
| 5.3.3.45 | Data Changes - Search/List Screen .....   | 880 |
| 5.3.3.46 | Hold/Release Instruction - Details Screen .....   | 881 |
| 5.3.3.47 | Hold/Release Instruction - New Screen .....   | 881 |
| 5.3.3.48 | Immediate Liquidity Transfer Order - New Screen .....                                   | 883 |
| 5.3.3.49 | Immediate Liquidity Transfer Order- Details Screen .....                                | 883 |
| 5.3.3.50 | Immediate Liquidity Transfer Orders - Search/List Screen .....                          | 884 |
| 5.3.3.51 | Inbound File - Details Screen .....   | 884 |
| 5.3.3.52 | Inbound Files - Search/List Screen .....  | 884 |
| 5.3.3.53 | Inbound Message - Details Screen .....  | 884 |
| 5.3.3.54 | Inbound Messages - Search/List Screen .....   | 885 |
| 5.3.3.55 | Insolvency procedure Settlement Instructions - Search/List Screen .....                 | 885 |

---

|              |  |            |
|--------------|--|------------|
| 5.3.3.56     | Intra-Balance Movement - Details Screen .....  | 885        |
| 5.3.3.57     | Intra-Balance Movement - New Screen.....   | 886        |
| 5.3.3.58     | Intra-Balance Movements - Search/List Screen .....   | 886        |
| 5.3.3.59     | Intra-Position Movement - Details Screen .....   | 887        |
| 5.3.3.60     | Intra-Position Movement - New Screen .....   | 887        |
| 5.3.3.61     | Intra-Position Movements - Search/List Screen .....  | 888        |
| 5.3.3.62     | Limit Utilisation - Search/List Screen .....   | 888        |
| 5.3.3.63     | Limit Utilisation Journal - Search/List Screen .....                                       | 888        |
| 5.3.3.64     | Maintenance Cash Instructions – Search/List Screen .....                                   | 888        |
| 5.3.3.65     | Maintenance Securities Instructions – Search/List Screen .....                             | 889        |
| 5.3.3.66     | Outbound File - Details Screen .....   | 890        |
| 5.3.3.67     | Outbound Files - Search/List Screen.....   | 890        |
| 5.3.3.68     | Outbound Message - Details Screen.....   | 891        |
| 5.3.3.69     | Outbound Messages - Search/List Screen .....   | 891        |
| 5.3.3.70     | Outstanding Auto-Collateralisation Credits - Search/List Screen ..                         | 892        |
| 5.3.3.71     | Overall Liquidity - Search/List Screen .....   | 892        |
| 5.3.3.72     | Penalty – Search/List Screen .....   | 892        |
| 5.3.3.73     | Penalty – Details Screen .....   | 893        |
| 5.3.3.74     | Monthly Net Penalty Amounts – Search/List Screen .....                                     | 893        |
| 5.3.3.75     | Penalty Removal Screen .....   | 893        |
| 5.3.3.76     | Penalty Re-allocation Screen .....   | 894        |
| 5.3.3.77     | Penalty Switch Screen.....   | 894        |
| 5.3.3.78     | Resend Communication Screen .....  | 894        |
| 5.3.3.79     | Revisions/Audit Trail - List Screen.....   | 895        |
| 5.3.3.80     | Securities Position - Details Screen .....   | 897        |
| 5.3.3.81     | Securities Positions - Search/List Screen.....   | 897        |
| 5.3.3.82     | Securities Postings - Search/List Screen .....   | 897        |
| 5.3.3.83     | Securities Restriction Details - Search/List Screen .....                                  | 898        |
| 5.3.3.84     | Settlement Instruction - Details Screen .....  | 898        |
| 5.3.3.85     | Settlement Instruction - New Screen .....  | 898        |
| 5.3.3.86     | Settlement Instructions - Search/List Screen .....   | 903        |
| 5.3.3.87     | Status History - Details Screen.....   | 903        |
| 5.3.3.88     | T2S DCA Balance - Details Screen .....   | 903        |
| 5.3.3.89     | T2S DCA Balances - Search/List Screen .....  | 903        |
| 5.3.3.90     | T2S DCA Postings - Search/List Screen .....  | 903        |
| 5.3.3.91     | Total Amount of Standing/Predefined Liquidity Transfer Orders -<br>Search/List Screen..... | 904        |
| 5.3.3.92     | Total Collateral Value per T2S Dedicated Cash Account - Search/List<br>Screen.....         | 904        |
| <b>5.3.4</b> | <b>Privilege Classes for LTSI Screens .....</b>  | <b>904</b> |
| <b>5.3.5</b> | <b>Privileges for LTSI Screens.....</b>  | <b>905</b> |

---

|          |  |     |
|----------|--|-----|
| 5.3.5.1  | BSIQ.01 - Multi-criteria search of a set of Settlement Instructions -<br>List Screen .....             | 905 |
| 5.3.5.2  | BSIQ.00 - Individual Settlement detailed Query – List Screen .....                                     | 906 |
| 5.3.5.3  | BSIQ.00 - Individual Settlement detailed Query – Search Screen   | 906 |
| 5.3.5.4  | BSIQ.01 - Multi-criteria search of a set of Settlement Instructions -<br>Search Screen .....           | 906 |
| 5.3.5.5  | BSIQ.02 - Individual Restriction detailed Query – List Screen .....                                    | 907 |
| 5.3.5.6  | BSIQ.02 - Individual Restriction detailed Query – Search Screen  | 907 |
| 5.3.5.7  | BSIQ.03 - Multi-criteria search of a set of Settlement Restrictions -<br>List Screen .....             | 907 |
| 5.3.5.8  | BSIQ.03 - Multi-criteria search of a set of Settlement Restrictions -<br>Search Screen .....           | 908 |
| 5.3.5.9  | BSIQ.04 - Multi-criteria search of a set of Liquidity Transfers - List<br>Screen.....                  | 908 |
| 5.3.5.10 | BSIQ.04 - Multi-criteria search of a set of Liquidity Transfers - Search<br>Screen.....                | 908 |
| 5.3.5.11 | BSIQ.05 - Multi-criteria search of a set of Business Cancellations -<br>List Screen .....              | 909 |
| 5.3.5.12 | BSIQ.05 - Multi-criteria search of a set of Business Cancellations -<br>Search Screen .....            | 909 |
| 5.3.5.13 | BSIQ.06 - Multi-criteria search of a set of Amendment Instructions –<br>List Screen .....              | 909 |
| 5.3.5.14 | BSIQ.06 - Multi-criteria search of a set of Amendment Instructions -<br>Search Screen .....            | 910 |
| 5.3.5.15 | BSIQ.07 - Multi-criteria search of a set of Hold and Release Instruc-<br>tions - List Screen .....     | 910 |
| 5.3.5.16 | BSIQ.07 - Multi-criteria search of a set of Hold and Release Instruc-<br>tions - Search Screen.....    | 910 |
| 5.3.5.17 | BSIR.00 - T2SDCA: Finalised matched Instructions – List Screen<br>.....                                | 911 |
| 5.3.5.18 | BSIR.00 - T2SDCA: Finalised matched Instructions – Search Screen<br>.....                              | 911 |
| 5.3.5.19 | BSIR.01 - Securities Account: Finalised matched Instructions - List<br>Screen.....                     | 911 |
| 5.3.5.20 | BSIR.01 - Securities Account: Finalised matched Instructions -<br>Search Screen .....                  | 911 |
| 5.3.5.21 | BSIR.02 - T2SDCA: Detailed Finalised matched Settlement Instruc-<br>tions - List Screen .....          | 912 |
| 5.3.5.22 | BSIR.02 - T2SDCA: Detailed Finalised matched Settlement Instruc-<br>tions - Search Screen.....         | 912 |
| 5.3.5.23 | BSIR.03 - Securities Account: Detailed Finalised matched Settlement<br>Instructions - List Screen..... | 912 |

---

|          |  |     |
|----------|--|-----|
| 5.3.5.24 | BSIR.03 - Securities Account: Detailed Finalised matched Settlement Instructions - Search Screen.....                | 912 |
| 5.3.5.25 | BSIR.04 - T2SDCA: Follow-up by time slot of Settlement Activity - List Screen .....                                  | 913 |
| 5.3.5.26 | BSIR.04 - T2SDCA: Follow-up by time slot of Settlement Activity - Search Screen .....                                | 913 |
| 5.3.5.27 | BSIR.05 - T2SDCA: Comparison of Settlement activity between two time periods - List Screen .....                     | 913 |
| 5.3.5.28 | BSIR.05 - T2SDCA: Comparison of Settlement activity between two time periods - Search Screen.....                    | 913 |
| 5.3.5.29 | CMBR.00 - Journaling of Limit Utilisations of Primary CMB - Search Screen.....                                       | 914 |
| 5.3.5.30 | CMBR.00 - Journaling of Limits Utilisations of Primary CMB - List Screen.....  | 914 |
| 5.3.5.31 | CMBR.01 - Journaling of Limits Utilisations of Secondary CMB - List Screen.....                                      | 914 |
| 5.3.5.32 | CMBR.01 - Journaling of Limits Utilisations of Secondary CMB - Search Screen .....                                   | 914 |
| 5.3.5.33 | COLL.00 - T2SDCA: Follow-up by time slot of Settled Collateralisation Instructions - List Screen.....                | 914 |
| 5.3.5.34 | COLL.00 - T2SDCA: Follow-up by time slot of Settled Collateralisation Instructions - Search Screen .....             | 914 |
| 5.3.5.35 | COLL.01 - Securities Accounts: Follow up by time slot of Settled Collateralisation Instructions - Search Screen..... | 915 |
| 5.3.5.36 | COLL.01 - Securities Accounts: Follow-up by time slot of Settled Collateralisation Instructions - List Screen .....  | 915 |
| 5.3.5.37 | COLL.02 - T2SDCA: Settled or Cancelled (automatic or manual) Collateralisation Instructions - List Screen .....      | 915 |
| 5.3.5.38 | COLL.02 - T2SDCA: Settled or Cancelled (automatic or manual) Collateralisation Instructions - Search Screen.....     | 915 |
| 5.3.5.39 | CPST.00 - T2SDCA: Follow-up by time slot of Cash Postings - List Screen.....   | 915 |
| 5.3.5.40 | CPST.00 - T2SDCA: Follow-up by time slot of Cash Postings - Search Screen .....                                      | 916 |
| 5.3.5.41 | LIQU.00 - Liquidity Transfers - List Screen .....  | 916 |
| 5.3.5.42 | LIQU.00 - Liquidity Transfers - Search Screen.....   | 916 |
| 5.3.5.43 | REAL.00 - Detailed Realignment and Other Technical Instructions - List Screen .....                                  | 916 |
| 5.3.5.44 | REAL.00 - Detailed Realignment and Other Technical Instructions - Search Screen .....                                | 916 |
| 5.3.5.45 | REST.00 - Detailed Cash Restrictions - List Screen .....   | 917 |
| 5.3.5.46 | REST.00 - Detailed Cash Restrictions - Search Screen .....   | 917 |

---

|              |   |            |
|--------------|---|------------|
| 5.3.5.47     | REST.01 - Detailed Securities Restrictions - Search Screen .....  | 917        |
| 5.3.5.48     | REST.01 - Detailed Securities Restrictions - List Screen .....  | 917        |
| 5.3.5.49     | SPST.00 - Securities Account: Follow-up by time schedule of Securities Postings - List Screen .....   | 918        |
| 5.3.5.50     | SPST.00 - Securities Account: Follow-up by time schedule of Securities Postings - Search Screen .....   | 918        |
| 5.3.5.51     | XREP.00 - T2SDCA: Matched Cancelled Instructions - List Screen .....  | 918        |
| 5.3.5.52     | XREP.00 - T2SDCA: Matched Cancelled Instructions - Search Screen .....  | 919        |
| 5.3.5.53     | XREP.01 - Securities Account: Matched Cancelled Instructions - List Screen .....  | 919        |
| 5.3.5.54     | XREP.01 - Securities Account: Matched Cancelled Instructions - Search Screen .....  | 919        |
| 5.3.5.55     | XREP.02 - Finalised Non Matched Cancellations - List Screen ....  | 919        |
| 5.3.5.56     | XREP.02 - Finalised Non Matched Cancellations - Search Screen .....   | 920        |
| <b>5.3.6</b> | <b>Privileges for DWH Screens .....</b>   | <b>920</b> |
| <b>5.4</b>   | <b>List of References for Error Messages .....</b>  | <b>921</b> |
| <b>5.4.1</b> | <b>Reader's Guide .....</b>   | <b>921</b> |
| <b>5.4.2</b> | <b>References for Error Messages for T2S GUI Screens .....</b>  | <b>921</b> |
| 5.4.2.1      | All .....   | 921        |
| 5.4.2.2      | All Screens which allow the initiation of a query .....   | 924        |
| 5.4.2.3      | All Screens which allow the initiation of a second user action (4-eyes mode) .....  | 925        |
| 5.4.2.4      | Allegation Instruction - Details Screen .....   | 927        |
| 5.4.2.5      | Allegation Instructions - Search/List Screen .....  | 927        |
| 5.4.2.6      | Amendment Cash Instruction - Details Screen .....   | 927        |
| 5.4.2.7      | Amendment Cash Instruction - New Screen .....   | 927        |
| 5.4.2.8      | Amendment Securities Instruction - Details Screen .....   | 937        |
| 5.4.2.9      | Amendment Securities Instruction - New Screen .....   | 937        |
| 5.4.2.10     | Available Report - Current Settlement Day Cash Information (Following Settlement Day Cash Forecast) Report – Details Screen .                   | 952        |
| 5.4.2.11     | Available Report - Details Screen .....   | 952        |
| 5.4.2.12     | Available Report - Statement of Accounts - Details Screen .....   | 952        |
| 5.4.2.13     | Available Report - Statement of Executed Amendment Instructions for Intra-Balance Movements - Details Screen .....                              | 952        |
| 5.4.2.14     | Available Report - Statement of Executed Amendment Instructions for Intra-Position Movements and Settlement Instructions - Details Screen ..... | 953        |
| 5.4.2.15     | Available Report - Statement of Executed Cancellation Instructions for Intra-Balance Movements - Details Screen .....                           | 953        |

---

---

|          |  |     |
|----------|--|-----|
| 5.4.2.16 | Available Report - Statement of Executed Cancellation Instructions for Intra-Position Movements and Settlement Instructions - Details Screen ..... | 953 |
| 5.4.2.17 | Available Report - Statement of Holdings - Details Screen .....  | 953 |
| 5.4.2.18 | Available Report - Statement of Pending Amendment Instructions for Intra-Balance Movements - Details Screen.....                                   | 953 |
| 5.4.2.19 | Available Report - Statement of Pending Amendment Instructions for Intra-Position Movements and Settlement Instructions - Details Screen .....     | 953 |
| 5.4.2.20 | Available Report - Statement of Pending Cancellation Instructions for Intra-Balance Movements - Details Screen.....                                | 954 |
| 5.4.2.21 | Available Report - Statement of Pending Cancellation Instructions for Intra-Position Movements and Settlement Instructions - Details Screen.....   | 954 |
| 5.4.2.22 | Available Report - Statement of Pending Instructions - Details Screen .....  | 954 |
| 5.4.2.23 | Available Report - Statement of Pending Intra-Balance Movements - Details Screen.....  | 954 |
| 5.4.2.24 | Available Report - Statement of Pending Intra-Position Movements - Details Screen.....   | 954 |
| 5.4.2.25 | Available Report - Statement of Settled Intra-Balance Movements - Details Screen.....  | 954 |
| 5.4.2.26 | Available Report - Statement of Settled Intra-Position Movements - Details Screen.....   | 954 |
| 5.4.2.27 | Available Report - Statement of Settlement Allegements - Details Screen.....   | 955 |
| 5.4.2.28 | Available Report - Statement of Transactions - Details Screen ....   | 955 |
| 5.4.2.29 | Available Reports - Search/List Screen .....   | 955 |
| 5.4.2.30 | Broadcast - Details Screen .....   | 955 |
| 5.4.2.31 | Broadcast - New Screen.....  | 956 |
| 5.4.2.32 | Broadcasts - Search/List Screen .....  | 956 |
| 5.4.2.33 | Calendar - Details Screen .....  | 956 |
| 5.4.2.34 | Cancellation Cash Instruction - Details Screen .....   | 956 |
| 5.4.2.35 | Cancellation Cash Instruction - New Screen .....   | 956 |
| 5.4.2.36 | Cancellation Securities Instruction - Details Screen .....   | 958 |
| 5.4.2.37 | Cancellation Securities Instruction - New Screen.....  | 958 |
| 5.4.2.38 | Cash Forecast - Details Screen.....  | 964 |
| 5.4.2.39 | Cash Forecasts - Search/List Screen .....  | 964 |
| 5.4.2.40 | Collateral Value of a Security - Search/List Screen.....   | 965 |
| 5.4.2.41 | Collateral Value per T2S Dedicated Cash Account and Security - Search/List Screen.....   | 966 |
| 5.4.2.42 | Data Change - Details Screen .....   | 967 |

---



---

|          |   |      |
|----------|---|------|
| 5.4.2.43 | Data Changes - Search/List Screen .....                                   | 967  |
| 5.4.2.44 | Default Event Schedule - Details Screen .....                             | 967  |
| 5.4.2.45 | Hold/Release Instruction - Details Screen .....                           | 967  |
| 5.4.2.46 | Hold/Release Instruction - New Screen .....                               | 967  |
| 5.4.2.47 | Immediate Liquidity Transfer Order - Details Screen .....                 | 984  |
| 5.4.2.48 | Immediate Liquidity Transfer Order - New Screen .....                     | 984  |
| 5.4.2.49 | Immediate Liquidity Transfer Orders - Search/List Screen .....            | 990  |
| 5.4.2.50 | Inbound File - Details Screen .....                                       | 992  |
| 5.4.2.51 | Inbound Files - Search/List Screen .....                                  | 992  |
| 5.4.2.52 | Inbound Message - Details Screen .....                                    | 992  |
| 5.4.2.53 | Inbound Messages - Search/List Screen .....                               | 992  |
| 5.4.2.54 | Insolvency procedure Settlement Instructions- Search/List Screen<br>..... | 993  |
| 5.4.2.55 | Intra-Balance Movement - Details Screen .....                             | 994  |
| 5.4.2.56 | Intra-Balance Movement - New Screen .....                                 | 994  |
| 5.4.2.57 | Intra-Balance Movements - Search/List Screen .....                        | 1012 |
| 5.4.2.58 | Intra-Position Movement - Details Screen .....                            | 1014 |
| 5.4.2.59 | Intra-Position Movement - New Screen .....                                | 1014 |
| 5.4.2.60 | Intra-Position Movements - Search/List Screen .....                       | 1038 |
| 5.4.2.61 | Limit Utilisation - Search/List Screen .....                              | 1040 |
| 5.4.2.62 | Limit Utilisation Journal - Search/List Screen .....                      | 1041 |
| 5.4.2.63 | Maintenance Cash Instructions – Search/List Screen .....                  | 1041 |
| 5.4.2.64 | Maintenance Securities Instructions - Search/List Screen .....            | 1042 |
| 5.4.2.65 | Outbound File - Details Screen .....                                      | 1043 |
| 5.4.2.66 | Outbound Files - Search/List Screen .....                                 | 1043 |
| 5.4.2.67 | Outbound Message - Details Screen .....                                   | 1044 |
| 5.4.2.68 | Outbound Messages - Search/List Screen .....                              | 1045 |
| 5.4.2.69 | Outstanding Auto-Collateralisation Credits - Search/List Screen           | 1045 |
| 5.4.2.70 | Overall Liquidity - Search/List Screen .....                              | 1046 |
| 5.4.2.71 | Penalty - Details Screen .....  | 1046 |
| 5.4.2.72 | Penalty - Re-allocation Screen .....                                      | 1047 |
| 5.4.2.73 | Penalty – Removal Screen .....  | 1049 |
| 5.4.2.74 | Penalty - Switch Screen .....   | 1050 |
| 5.4.2.75 | Queued Static Data Change – Details Screen .....                          | 1050 |
| 5.4.2.76 | Queued Static Data Changes – Search/List Screen .....                     | 1050 |
| 5.4.2.77 | Resend Communication Screen .....   | 1051 |
| 5.4.2.78 | Revisions/Audit Trail - List Screen .....                                 | 1052 |
| 5.4.2.79 | Securities Position - Details Screen .....                                | 1052 |
| 5.4.2.80 | Securities Positions - Search/List Screen .....                           | 1053 |
| 5.4.2.81 | Settlement Instruction - Details Screen .....                             | 1054 |
| 5.4.2.82 | Settlement Instruction - New Screen .....                                 | 1054 |
| 5.4.2.83 | Settlement Instructions - Search/List Screen .....                        | 1115 |

---

|              |  |             |
|--------------|--|-------------|
| 5.4.2.84     | Status History - Details Screen.....   | 1118        |
| 5.4.2.85     | T2S BIC Directory Items - Search/List Screen .....   | 1118        |
| 5.4.2.86     | T2S DCA Balance - Details Screen.....  | 1120        |
| 5.4.2.87     | T2S DCA Balances - Search/List Screen .....  | 1120        |
| 5.4.2.88     | T2S DCA Postings - Search/List Screen .....  | 1121        |
| 5.4.2.89     | Total Amount of Standing/Predefined Liquidity Transfer Orders -<br>Search/List Screen..... | 1122        |
| 5.4.2.90     | Total Collateral Value per T2S Dedicated Cash Account - Search/List<br>Screen.....         | 1123        |
| <b>5.4.3</b> | <b>References for Error Messages for TMS Screens.....</b>                                  | <b>1124</b> |
| 5.4.3.1      | Trouble Case - Search/List Screen .....  | 1124        |
| 5.4.3.2      | Trouble Case - Details Screen .....  | 1124        |
| 5.4.3.3      | Trouble Case - Export Screen .....   | 1124        |

# Index

## B

|                   |    |
|-------------------|----|
| Buttons           | 42 |
| Button bar        | 34 |
| First             | 47 |
| Information panel | 33 |
| Last              | 47 |
| Next              | 47 |
| Previous          | 47 |
| T2S logo          | 33 |

## C

|                       |    |
|-----------------------|----|
| Characters            |    |
| SWIFT-x character set | 39 |
| UTF-8 character set   | 39 |

## E

|               |    |
|---------------|----|
| Error message | 49 |
|---------------|----|

## F

|                        |    |
|------------------------|----|
| Field types            |    |
| Check boxes            | 38 |
| Input fields           | 36 |
| Input-sensitive fields | 36 |
| Radio buttons          | 38 |
| Select fields          | 36 |
| Four-eyes mode         | 48 |
| Frame                  | 34 |

## G

|                          |    |
|--------------------------|----|
| Graphical user interface | 25 |
| Content area             | 33 |
| Header                   | 32 |
| Menu bar                 | 31 |
| Page layout              | 25 |
| Screen layout            | 32 |
| Structure                | 31 |

## I

|                          |        |
|--------------------------|--------|
| Icons                    | 42     |
| Add row                  | 45     |
| Alert                    | 51     |
| Auto-complete select box | 46     |
| Back                     | 34, 42 |
| Calendar                 | 45     |
| Collapse                 | 44     |
| Export                   | 34, 43 |
| Magnifier                | 46     |
| Print                    | 34, 42 |
| Refresh                  | 34, 43 |
| Sort                     | 47     |
| Information signs        |        |
| Example sign             | 26     |
| Notice sign              | 26     |

## O

|             |    |
|-------------|----|
| Online help | 53 |
|-------------|----|

## S

|                       |    |
|-----------------------|----|
| Screen reference part | 29 |
| Screen types          |    |
| Details screen        | 36 |
| Enter screen          | 36 |
| Search/List screen    | 35 |
| Welcome screen        | 35 |
| Screenshot            | 27 |
| Sub-frame             | 34 |
| Success message       | 49 |

## U

|                        |    |
|------------------------|----|
| UHB methodology        | 25 |
| UHB structure          | 28 |
| User administration    |    |
| Registration           | 53 |
| User instructions part | 29 |

---

**V**

---

Validation

|                        |        |
|------------------------|--------|
| Back-end validation    | 48, 48 |
| Confirmation prompt    | 48     |
| Cross-field validation | 48     |
| Field validation       | 48     |
| Front-end validation   | 48     |

**W**

---



|          |    |
|----------|----|
| Wildcard | 40 |
|----------|----|



## Disclaimer

All rights reserved. Reproduction for educational and non-commercial purposes is permitted provided that the source is acknowledged.

## Terms and Abbreviations

The terms and abbreviations used in the User Handbook, but not included in the T2S glossary are shown in the table below. You find terms with their description and the abbreviations, both in an alphabetical order.

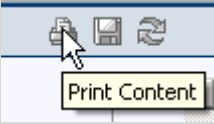
| Letter  | Description   |
|---|---|
| <b>A</b>  |   |
| Alert icon<br> | An <i>alert</i> icon is an icon that is shown on an active T2S screen for those users with appropriate rights to approve a pending action.  |
| A2A   | Application-to-application  |
| <b>B</b>  |   |
| BIC   | Bank identifier code  |
| <b>C</b>  |   |
| Check box<br> | Square box which can be filled with a checkmark by clicking on it with the mouse. In contrast to the radio button, you can select more than one option with a check box.  |
| <b>D</b>  |   |
| DD  | Day (e.g. used within the timestamp, every letter stands for one digit)   |
| d   | Decimal number  |
| <b>E</b>  |   |
| e.g.  | For example (Latin: 'exempli gratia')   |
| <b>G</b>  |   |
| GUI   | Graphical user interface which is a type of user interface which allows users to interact with electronic devices.  |
| <b>H</b>  |   |
| hh  | Hour (e.g. used within the timestamp, every letter stands for one digit)  |
| <b>I</b>  |   |
| i.e.  | That is (Latin: 'id est')   |
| IP port   | Internet Protocol address port, is the port which connects a numerical label assigned to each device (e.g., computer, printer) participating in a computer network that uses the Internet Protocol for communication. |
| Incl.   | Including   |

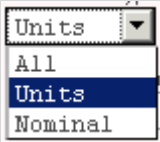
| Letter  | Description   |
|---|---|
| <b>M</b>  |   |
| Mouse-over<br>     | Additional information for some elements of the GUI is only shown when you move the mouse-pointer to these elements.  |
| MM  | Month (e.g. used within the timestamp, every letter stands for one digit)   |
| mm  | Minute (e.g. used within the timestamp, every letter stands for one digit)  |
| µsµsµsµsµs  | Microsecond (e.g. used within the timestamp, every 'µs' stands for one digit)   |
| min.  | Minimum   |
| max.  | Maximum   |
| 10m   | 10 million  |
| <b>N</b>  |   |
| NRO   | Non-repudiation of origin (NRO) provides the recipient (T2S) with the evidence NRO which ensures that the originator (T2S actor) will not be able to deny having sent the U2A instruction. The evidence of origin is generated by the originator and held by the recipient. |
| <b>Q</b>  |   |
| QQ  | Quarter, indicates a time span of three months, e.g. Q2 stands for the second quarter of the year.  |
| <b>R</b>  |   |
| Radio button<br> | A type of GUI element which allows the user to choose only one of a predefined set of options.  |
| <b>S</b>  |   |
| Select box<br>   | A select field in the GUI with an arrow on the right side. By clicking on the arrow, all possible input values are shown and can be selected with a mouse-click.  |
| SS  | Semester, indicates a time span of six months, e.g. S1 stands for the first semester.   |

---

| Letter    | Description  |
|-----------|--|
| ss        | Second (e.g. used within the timestamp, every letter stands for one digit) |
| <b>T</b>  |  |
| 10t       | 10 thousand  |
| Timestamp | A sequence of characters, denoting the date and the time in T2S.           |
| <b>U</b>  |  |
| UHB       | User Handbook  |
| U2A       | User-to-application  |
| <b>Y</b>  |  |
| YYYY      | Year (e.g. used within the timestamp, every letter stands for one digit)   |



# 1 Introduction

## 1.1 Overview of the User Handbook

The T2S User Handbook, hereinafter called UHB, aims at facilitating the use of the Graphical User Interface of TARGET2-Securities (T2S GUI) and related common components: Common Reference Data Management (CRDM), Business Day Management (BDM), Billing common component (BILL). It is intended for any T2S user regardless of the focus of activities and describes the full range of functionalities available in user-to-application (U2A) mode. The UHB provides detailed reference information on all GUI screens and step-by-step instructions for typical workflows.

**Target Audience** There is only one handbook addressing all T2S actors: central banks (CBs), central securities depositories (CSDs), CSD participants, external CSD users, payment banks/settlement banks. By referring to the table of contents as well as to the usage indication list, each reader can easily identify the relevant parts.

**Related Documentation** The UHB is part of the functional documentation and complements the general, technical and detailed specifications. Among these, the UDFS is particularly relevant for UHB readers. Although it is mainly focused on the application-to-application mode (A2A), chapter one of the UDFS contains a detailed description of the business concepts used in T2S, which are also relevant when using the GUI.

In addition to the T2S specifications, the Business Functionality for T2S Graphical User Interface - as the basis for the design and implementation of the GUI - provides helpful information. References to the GUI Business Functionalities are made in the screen descriptions of the UHB.

Both documents are available on the ECB's T2S webpage.



**Updates** Updated versions of the UHB will be provided on a regular basis.

### 1.1.1 UHB Methodology

Several symbols and methodological elements are used throughout the T2S UHB to ease orientation and help you to find your desired information quickly.

**Page Layout** Every page of the main UHB parts has a similar page layout. You can find four different elements:

- the header, which shows the chapter and sub-chapter title
- the margin column on the left side of each page, which is used for subheadings and information signs
- the text column, which contains the main information, tables and screenshots
- the footer, which shows the name and the release of the document as well as the page number

| Information Signs | Name         | Icon  | Description   |
|-------------------|--------------|---|---|
|                   | Notice sign  |  | Notice signs are used to highlight useful information. Read its content to find out about hints, action alternatives or other details helping you to improve your usage of the T2S GUI. |
|                   | Example sign |  | Example signs are used to highlight examples, which illustrate the corresponding text, especially when a verbal description is difficult or too extensive.                              |

**Links** Links are illustrated throughout the UHB with a little triangle followed by a page number within squared brackets. These links help you to jump to related sections by clicking on them or turning to the relevant page.

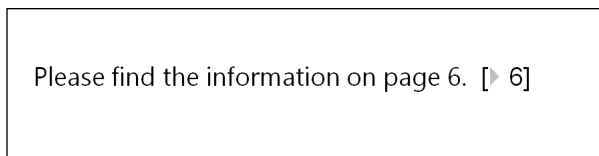

Illustration 1: Link illustration

**Tables** Tables are used to present information in a clearly arranged format. They consist of a table head and a table body. The body is divided into a left and a right column. The left column contains keywords, for example field names, which are explained in the right column. Subsections within a table are preceded by a heading. The order of the description follows the appearance on the screen from left to right and from top to bottom.

**Type Set** Regular text in the UHB is written in Arial Unicode MS font with a size of 11pt. Screen and button names are written in italic letters, GUI paths use the Courier New font. Field names and field values are put in quotation marks if they appear in a context other than their dedicated description.

| Element     | Format         | Example                                  |
|-------------|----------------|--|
| Screen name | Italic letters | <i>Data changes – search/list</i> screen |
| Button name | Italic letters | <i>New</i> button                        |

| Element                       | Format  | Example  |
|-------------------------------|---------|--|
| GUI path                      | PC code | T2S >> Market-Specific Configuration >> Market-Specific Attributes >> Search |
| Field name or value quotation | '...'   | 'Opening Date' ; 'Active'  |

**Action Steps** Business scenarios are divided into single action steps. These action steps are numbered sequentially. Intermediate results are described where appropriate and marked with an indented arrow. Each business scenario ends with a final result, indicated by an arrow.



#### Example

1. Action step 1
2. Action step 2
  - ➔ Intermediate result
3. Action step 3
  - ➔ Result

**Screenshots** Screenshots are used to illustrate the corresponding text. Note that there might be minor deviations between the screenshot and your screen appearance, according to your access rights or a specific selection you have made. Also, some functions are mutually exclusive and cannot be represented in a single screenshot. In these cases, the screenshot illustrates the more prevalent use of the screen.

Values shown on a screenshot might also deviate from the default values indicated in the description. In these cases, the description is valid rather than the screenshot.

Wherever relevant, specific parts of a screenshot are highlighted with a red box. If there is more than one box, position numbers point out the relation to the corresponding description.

The screenshot shows a web application interface for 'Immediate Liquidity Transfer'. The top navigation bar includes 'SECURITIES', 'CASH', 'SERVICES', and 'MONITORING'. The breadcrumb trail is 'Cash > Liquidity > Immediate Liquidity Transfers > New Immediate Liquidity Transfer'. The version number 'version 0.91-01' is visible in the top right. The main form is titled 'Immediate Liquidity Transfer' and is divided into three sections: 'Debit Cash Account', 'Liquidity Transfer', and 'Credit Cash Account'. In the 'Debit Cash Account' section, the 'Debitor BIC' field is highlighted with a red box, and a red circle with the number '1' is placed to its right. The 'Liquidity Transfer' section contains 'Users Reference' (with 'T2S' entered) and 'Amount'. The 'Credit Cash Account' section has radio buttons for 'Outbound Liquidity Transfer' (selected) and 'Internal Liquidity Transfer', along with fields for 'External Account Number', 'T2S Dedicated Cash Account Number', and 'Creditor BIC'.

Illustration 2: Screenshot with red box and position number

## 1.1.2 UHB Structure

The UHB is structured in five parts and is complemented by an annex.

### Part 1

The **introduction** explains the aim, the content and the approach of both the UHB and the GUI. While the first section explains how to use the UHB, the second section focuses on the design and common functionalities of the GUI.

The overview of the UHB includes information about:

- The UHB methodology [▶ 25]
- The UHB structure [▶ 28]

The overview of the GUI consists of information about:

- Setup and login procedures [▶ 30]
- GUI structure for T2S GUI [▶ 31], including information about the menu structure [▶ 31], screen structure [▶ 32], screen types [▶ 34], field types and properties [▶ 36], and common buttons and icons [▶ 42]
- GUI structure for CoCo GUI [▶ 56], including information about the menu structure [▶ 57], screen structure [▶ 57], screen types [▶ 59], field types and properties [▶ 60], and common buttons and icons [▶ 67]
- Validation [▶ 48]
- Communication network and services [▶ 53]
- User administration [▶ 53]
- Security and certification services [▶ 53]
- Online help [▶ 53]

Refer to this part if you need information on how to use the UHB or on common functionalities of the GUI.

**Part 2**

The **screen reference part** starts with a general section serving as a reader's guide for this part. It is followed by the screen descriptions of all screens contained in the GUI. Each description follows an identical structure which comprises detailed information on all screen fields.

The screen reference part is structured along the first and second GUI menu level, followed by the screens in alphabetical order. Within this alphabetical order, all screen types belonging to the same business function are grouped together to follow the business logic (*search/list* screen, *details* screen, *new/edit* screen).

Refer to this part if you need detailed and precise information on a screen, field or button.

**Part 3**

The **user instructions part** starts with a general section serving as a reader's guide for this part. It is followed by step-by-step instructions for typical GUI workflows, called business scenarios. Each description follows an identical structure.

Related business scenarios are grouped into comprehensive business packages, which are further grouped into categories.

Refer to this part if you need to know how to carry out an action using the GUI.

**Part 4**

The **trouble management system (TMS)** part offers an overview of the TMS screens that are available in U2A mode. Refer to this part if you need a description and explanation of the usage and functionalities of the TMS external interface to the relevant users.

TMS is a tool and database which is used to track and follow-up on relevant communication between the T2S users and the T2S Service Desk for which a trouble case has been created.

**Annex**

The **annex** supplies detailed information complementing the UHB:

- Annex A - Indication of usage [▶ 808]: List of primary users (CSD or CB) for each screen and business scenario
- Annex B - Sitemap [▶ 820]: Hierarchical, structured illustration of all screens and their interrelations
- Annex C - List of privileges [▶ 842]: For each screen, all privileges and their corresponding description are listed
- Annex D - List of references for error messages [▶ 921]: For each screen (incl. TMS screens), all references for error messages, the error text and the corresponding description are listed

## 1.2 Overview of the Graphical User Interface for T2S GUI

The GUI is a browser-based application for communication with T2S in U2A mode. It is based on the ISO norm 9241 'Ergonomics of human system interaction'.

### 1.2.1 Setup and Login Procedures

Before entering the GUI, make sure that your workstation complies with the hardware and software requirements and implement all necessary preparations (e.g. firewall settings) described below.

|  |  |
|--|--|
| <b>Hardware Requirements</b>               | Please refer to ESMIG qualified configurations document annexed to the ESMIG UDFS.   |
| <b>Software Requirements</b>               | Please refer to ESMIG qualified configurations document  |
| <b>Supported Web-Browsers and Settings</b> | Please refer to ESMIG qualified configurations document annexed to the ESMIG UDFS.   |
| <b>Firewall Settings</b>                   | Please refer to ESMIG qualified configurations document annexed to the ESMIG UDFS.   |
| <b>GUI Access</b>                          | Users are directed to an initial page named ESMIG portal that ensures proper routing to the web applications the user has been granted to enter.   |
| <b>Authentication</b>                      | Authentication takes place on the login screen provided by the network provider (SWIFT or Nexi). On this login screen you are requested to authenticate yourself via the certificate used together with your password. Both pieces of information (choosing a certificate and typing in a password) are only required once at the beginning of every session and the authentication remains active for the entire session. |
| <b>System User Reference</b>               | Please refer to ESMIG qualified configurations document annexed to the ESMIG UDFS.   |
| <b>Limitations of the T2S GUI</b>          | The T2S GUI is designed as a user interface where a user handles entries into the T2S GUI and views the result of queries, reports etc. on his computer screen. It is recommend to use the T2S GUI in a restrictive way, i.e. using search parameters to limit the resulting data volume and avoid open ended queries.   |

In case the user does not consider this limitation the T2S GUI would first wait and finally could run into a time-out. Depending on various parameters (bandwidth, concurrent users, customer infrastructure processing, DB query duration, record size, operational day phase, timeout limitation) further effects may be encountered.

## 1.2.2 GUI Structure

This chapter explains the basic elements of the T2S GUI structure (i.e. structure of the menu and the screens) helping you to navigate through the system and to use it quickly and efficiently.

The first subsection describes the menu structure where screens are grouped hierarchically. Afterwards, the second subsection explains the layout structure common to each screen. The following subsections provide details on the different screen types [▶ 34] and on recurring elements, such as common field types [▶ 36] or buttons and icons [▶ 42].

### 1.2.2.1 Menu Structure

The GUI menu is structured into three hierarchical menu levels. The first level is presented as a menu bar containing the five first-level menu items, which are always visible on top of each screen.



---

#### Hint

Depending on your access rights, it is possible that not all menu entries are visible for you. Contact your system administrator to verify that you have the necessary privileges to access all screens relevant to you. The privileges are listed in each screen and business scenario description.

---

The items are colour-coded for ease of referencing:

- Securities (orange)
- Cash (green)
- Services (blue)
- Monitoring (yellow)

The second and third menu levels are accessible via mouse-over on the first-level menu items.

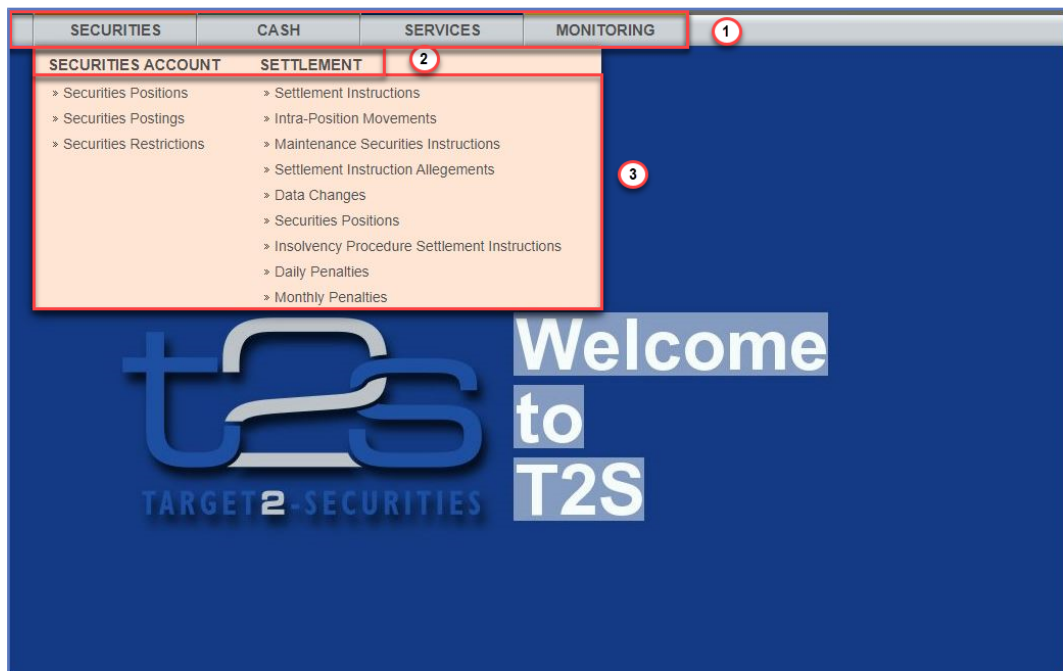

Illustration 3: T2S menu levels

| Position No. | Description  |
|--------------|--------------|
| 1            | Menu level 1 |
| 2            | Menu level 2 |
| 3            | Menu level 3 |

All entries on the second menu level are structural subcategories. To access a screen you have to click on the third menu level. For ease of use, some screens are available more than once. All identical menu entries on level three lead to the same screen. You can arbitrarily access them according to your business preferences.



### Example

The *securities positions – search/list* screen can be accessed via the following two paths:

- Securities >> Securities Account >> Securities Positions
- Securities >> Settlement >> Securities Positions

## 1.2.2.2 Screen Structure

In general, each screen of the T2S GUI follows the same layout containing a header and a content area.

### Header

The header appears at the top of every screen. It contains four main elements providing useful information and helping you to navigate between the different screens as shown in the illustration below.



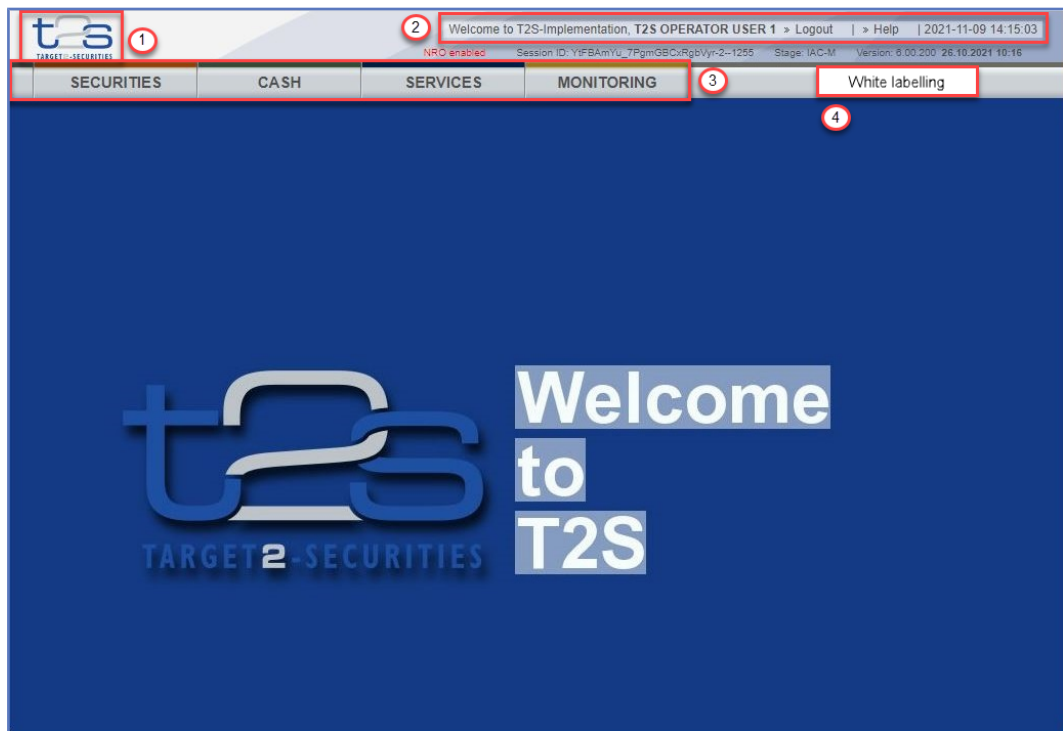

Illustration 4: Header elements

| Position No. | Element                        | Description   |
|--------------|--------------------------------|---|
| 1            | T2S logo button                | ... links to the welcome screen. While using the <i>new/edit</i> screens, the <i>T2S logo</i> button is locked in order to ensure a safe and complete submission process. |
| 2            | Information panel              | ... displays your login name, the <i>logout</i> and <i>help</i> buttons as well as date and time of last data access.   |
| 3            | Menu bar                       | ... presents the five main menu items and allows you to navigate to the screens.  |
| 4            | T2S System User Reference logo | ... displays the respective logo in accordance with the chosen T2S system user reference in line with the white-labelling approach.                                       |

**Content Area** The content area is the part of the GUI where you can trigger all business actions. It is organised by five main elements which help you to interact properly with the GUI as shown in the illustration below.

To structure large amounts of data, the content area is further separated into frames and sub-frames.

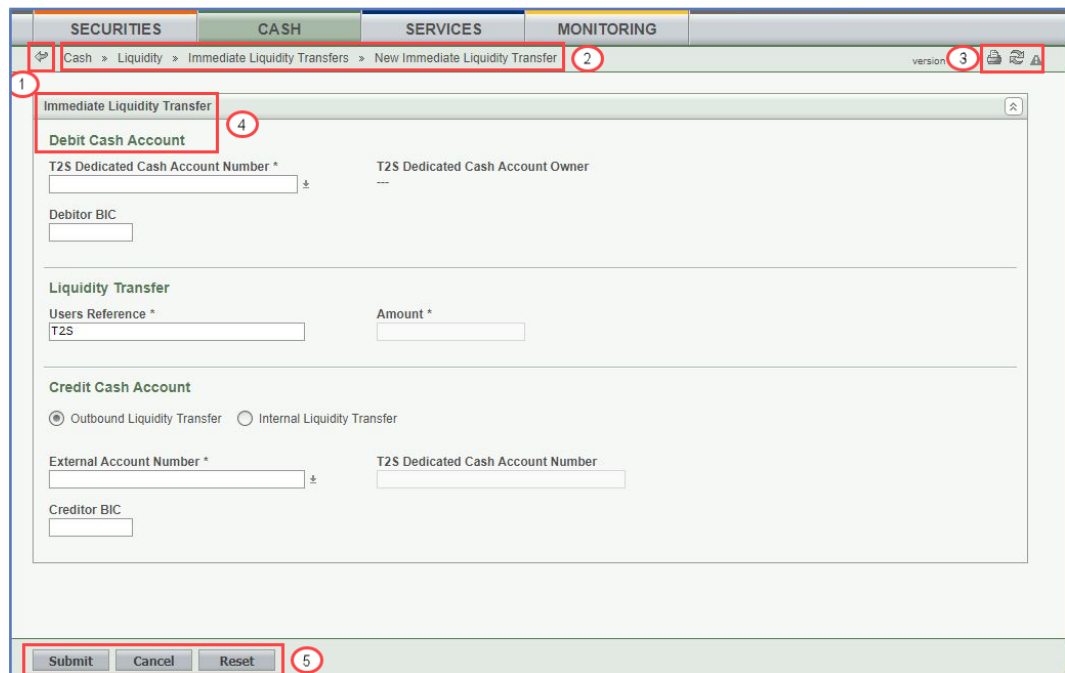

Illustration 5: Content area elements

| Position No. | Element                   | Description   |
|--------------|---------------------------|---|
| 1            | Back icon                 | ... leads to the previous screen.   |
| 2            | Breadcrumb                | ... shows the main path to the current screen.                            |
| 3            | Print icon                | ... prints the screen content.  |
|              | Export icon               | ... exports the content, which can then be saved to your local directory. |
|              | Refresh icon              | ... reloads the screen.   |
| 4            | Frame and sub-frame title | ... groups related information as a structural function.                  |
| 5            | Button bar                | ... shows all available buttons for the current screen.                   |

Further information about the icons can be found in the common buttons and icons section [▶ 42].

### 1.2.2.3 Screen Types

The T2S GUI consists of the following types of screens, each with a different function:

- Welcome screen
- Search/List screen
- Details screen
- Enter screen (usually new or edit screen)

---

|                           |   |
|---------------------------|---|
| <b>Welcome Screen</b>     | The <i>welcome</i> screen is the entrance into the T2S GUI and allows you to choose your system user reference. It also contains a ticker line providing you with the latest information. The ticker is managed by the T2S operator.  |
| <b>Search/List Screen</b> | <p>Generally, you can access all <i>search/list</i> screens on menu level three. You can find all possible ways of accessing the screen directly in the respective screen description within the screen reference part.</p> <p>The <i>search/list</i> screen allows you to query the T2S database using a predefined set of search criteria. After executing a search, a list of data records matching your search criteria is displayed in a table. To select an entry from a list displayed on a <i>search/list</i> or <i>list</i> screen, click on the desired entry. The background colour of the table line changes to indicate the selected entry. If the search retrieves only one record, the <i>details</i> screen is displayed directly, if you are authorised to access the details screen, else the record is displayed in the table in the list screen. You can browse through the list using the table buttons [▶ 42]. Furthermore, it is possible to arrange your search results in ascending or descending order by the columns shown. This does not trigger a refreshed query.</p> |



---

**Hint**

If you find underlined static data objects (e.g. like a hyperlink on a webpage) in a list, this is an indication that there is further information available. By clicking on such an entry a new query is started and the corresponding information to this entry is shown in a separate pop-up window.

---

You can also execute a new search with different search criteria by changing the values in the search fields and clicking on the *search* button, triggering a new query.

The search/list function is usually combined in one screen. Before proceeding further with a screen button, select one of the data records in the table by clicking on it.



---

**Hint**

If you submit a query for a business object (e.g. eligible counterparty CSD) in a 'Valid from - Valid to' range, the query retrieves the values of the main business object and the values of the linked business object (e.g. investor BIC, parent BIC).

For the main business object, you receive the valid values of the 'Valid from - Valid to' range.

For the linked business object, you always receive the currently valid values of the date of the search and not the valid values of the 'Valid from - Valid to' range.

---

**Details Screen** In contrast to the *search/list* screen, you can only access the *details* screens via other screens. As the only exception, the *T2S calendar* screen is already available on menu level three. You can find all possible ways of accessing the screen via other screens in the respective screen description within the screen reference part.

All *details* screens provide you with in-depth information of a previously selected data record.

Before showing the *details* screen, a new query is forwarded to the system to ensure most up-to-date data.

**Enter Screen** Similar to the *details* screens, you can only access the *enter* screens through other screens, except for the *resend communication* screen, which is already available on menu level three.

*Enter* screens allow you to enter data, which can be done in two enter modes:

- New mode, represented by the *new* screens
- Edit mode, represented by the *edit* screens

In general, both modes contain the same fields. In the case of the *new* mode, all fields are blank. In the case of the *edit* mode, existing data are prefilled in the fields. In addition, one past value is reported (if available) which cannot be edited. You can edit the existing currently valid value by changing the content of the field. You can also enter a new future value by clicking on the *pencil* icon [▶ 42]. You can only edit an existing currently valid value if there is no future value stored.

As a general rule, all the 'Instructing Party BIC' and 'Instructing Party Parent BIC' fields are automatically filled in with the respective 'Party BIC' of the current GUI user in case they are not filled in when clicking on the *submit* button.

## 1.2.2.4 Field Types and Properties

On *search/list* and *enter* screens, you can enter information via input fields and select fields. Information is displayed in read-only fields.

### Field Types

**Input Fields** In input fields you can enter text and/or numeric content. Make sure to comply with the format requirements, which are part of each field/screen description.

Input-sensitive fields are input fields with an auto-complete mode that helps you to input data. As soon as you start typing the first characters of the respective data into an input-sensitive field, T2S automatically proposes possible matching entries from which you can select the desired one.

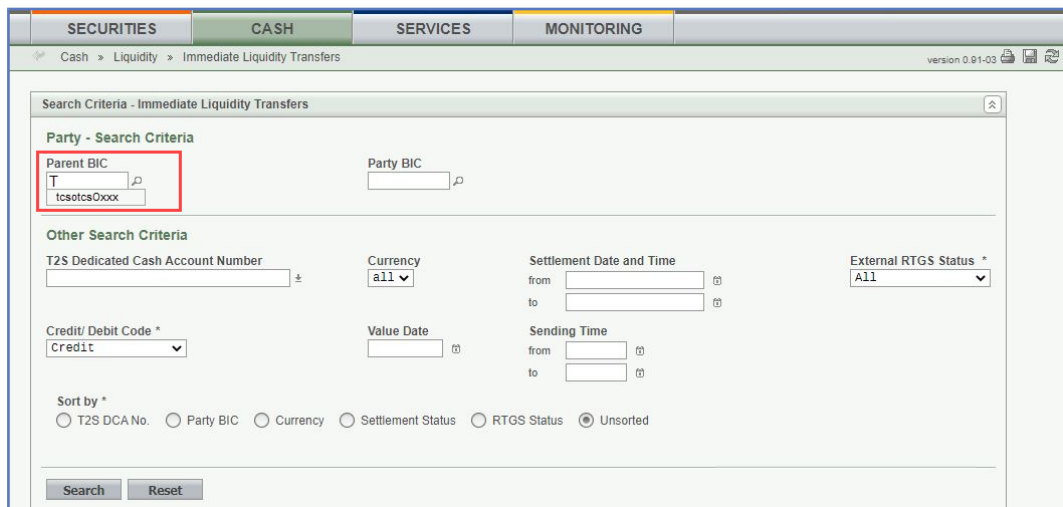

Illustration 6: Input-sensitive field



**Hint**

You can use the tab key on your keyboard to navigate through the GUI fields.

BIC8 that are entered via GUI are automatically supplemented to BIC11 by adding 'XXX' in order to unambiguously identify a party with the exception of the BICs referring to parties on party level 3-5 of the 'Settlement Instruction – New Screen'.

**Select Fields**

Select fields are either select boxes, radio buttons or check boxes.

- **Select boxes:** Functionally a select box is a way to enter data from a limited list of possible values. In T2S you can find different types of select boxes: standard select box and auto-complete select box.
- The **standard select box** enables you to choose one entry from a pre-defined set of values. To select an entry, click on the little box with the arrow to open the menu. Then select the desired value by clicking on it.

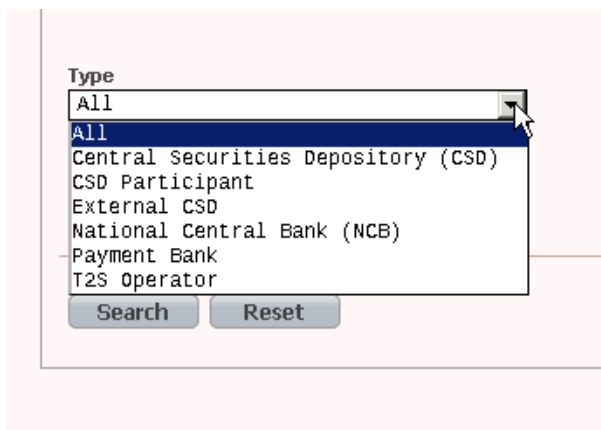

Illustration 7: Standard select box

The **auto-complete select box** enables you to either enter your desired value manually which will be used to reduce the possible set of values in the auto-complete select box to be chosen from or to click on the *auto-complete select box* icon, which provides you with a drop-down menu that shows the 10 first entries of the set of values irrespective of what you might have entered in the text field. In either way (meaning clicking on the icon or start typing an entry with the automatically shown list) up to 10 entries will be shown in the drop-down menu.



Auto-complete select box using the *auto-complete select box* icon and auto-complete select box with manually entered values.

The **google-style select box** enables you, on difference to the auto-complete select box, to make entries and choose values outside the standard set of values to be sent to the back-end for further validation (extended data scope). Due to that possibility of transporting unqualified data the validation of the values is restricted to basic checks and will be carried out mainly in the backend. Apart from that, the google-style select box functions similar to the auto-complete select box.



Illustration 8: Google-style select box

- Radio buttons:** Enable you to make exact selections using one value from a set of options. You can select only one value at the same time. Click on the icon corresponding to the option you would like to select.

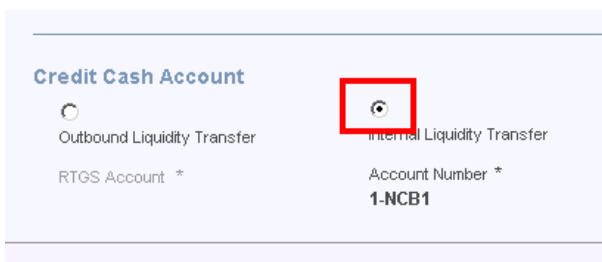

Illustration 9: Radio buttons

- Check boxes:** Enable you to select more than one value at the same time. Click on the boxes corresponding to the options you would like to select. Selected check boxes contain a check mark.

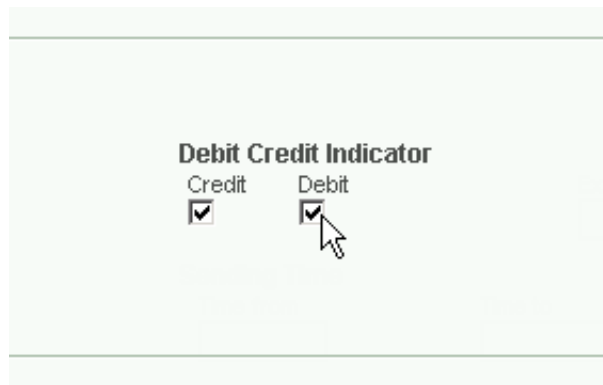

Illustration 10: Check boxes

### Read-only Fields

In addition to enter and select fields, the T2S GUI has also read-only fields, which are pre-filled and do not allow data changes.

### Field Properties

All field types have specific properties with respect to possible character sets, usage of wildcards and mandatory content.

### Characters

T2S operates in British English and uses the SWIFT-x character set to enter data. After the coexistence, T2S will be using the UTF-8 character set with the exception of '<', '>' and '&'. Amounts are automatically displayed with decimal points. While negative amounts are displayed in red and marked with a '-', you can only type amounts that are greater than or equal to 0 into input fields, unless specified otherwise in the screen description.

The GUI does not differentiate between upper and lower case in terms of data input for input fields.



#### Hint

Use the abbreviations 10m to enter the amount of 10 million (10,000,000) and 10t to enter the amount of 10 thousand (10,000).

The SWIFT-x character set is used in the text fields during the period of coexistence and corresponds with the following content:

| Character | Description                                 |
|-----------|---|
| a - z     | 26 small characters of the Latin alphabet   |
| A - Z     | 26 capital characters of the Latin alphabet |
| 0 - 9     | 10 numeric characters                       |
| /         | Solidus (slash)                             |
| -         | Hyphen                                      |
| ?         | Question mark                               |
| :         | Colon                                       |

|    |                     |
|----|---------------------|
| (  | Opening parenthesis |
| )  | Closing parenthesis |
| .  | Full stop           |
| ,  | Comma               |
| '  | Apostrophe          |
| +  | Plus                |
|    | Space (blank)       |
| CR | Carriage return     |
| LF | Line feed           |



### Hint

T2S does not process fields (mandatory or optional), that are only filled with blanks. Blanks appearing at the beginning or at the end of a field entry are deleted automatically without any notification.

Fields in a *list* or *details* screen, where the dataset was saved without an entry, are filled with '---'.

Some reference and identification fields need a reduced version of the SWIFT-x character set. For them, the character '/' cannot be accepted at the beginning or end of the string. Moreover the combination '/' cannot be present in any part of the string itself.

These fields are identified by the SWIFT-x-red type.

Please note that because blank characters are always deleted from the beginning or end of the input – any sequence like ' / ' (for the beginning) or ' / ' (for the end) must be considered not accepted.

### Wildcards

A wildcard is a placeholder for characters. In T2S you can use a wildcard in an input field to search for data. The required number of characters is indicated in the field description. You can use wildcards in two different ways:

- As a placeholder for one or more characters of the input value, use an asterisk ('\*')
- As a placeholder for exactly one character of the input value, use a question mark ('?')





### Examples

TARGET2\*: The result list contains all data records beginning with 'TARGET2'.

\*Securities: The result list contains all data records ending with 'securities'.

TARGET2-Securities: The result list contains all data records that have exactly one character before the 'TARGET2-Securities'.

The combination of several wildcards directly after each other is not possible (e.g. TARGET2?\* or TARGET2\*\*), but it is possible to use several wildcards within one entry (e.g. 'TARGET2-\*').

To properly search with wildcards, you have to insert at least two or four characters depending on the field requirements. If the fields do not allow wildcards, it is mentioned explicitly in the respective field description (under format requirements). Please note that the wildcard functionality is only available for input fields and not for select boxes.

### Mandatory Content

In the GUI all mandatory fields are marked with an asterisk in the label. All marked fields have to be filled in before you are allowed to proceed.

Illustration 11: Mandatory fields

| Position No. | Description            |
|--------------|------------------------|
| 1            | Mandatory input field  |
| 2            | Mandatory select field |

### 1.2.2.5 Common Buttons and Icons

While working with the T2S GUI you will find that some buttons and icons appear regularly. There are three types of common elements:

- Basic icons, which you can find on every screen
- Utility elements, which represent functions within the content area
- Table elements, which you can find below data record lists on *search/list*

The buttons contained in the button bar are variable and therefore explained in the screen descriptions.

#### Basic Icons

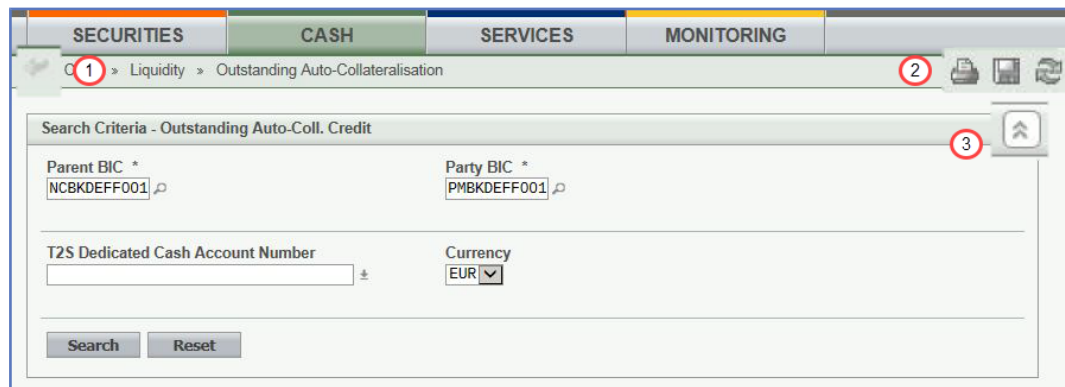

Illustration 12: Basic buttons

| Position No. | Element           | Description   |
|--------------|-------------------|---|
| 1            | <i>Back</i> icon  | <p>... always leads to the previous functional screen.</p> <p>The usage of the <i>back</i> icon does not lead to an update or a refresh of the query of the screen.</p> <p>Do not use the <i>back</i> button of your web-browser to return to the previous screen, to avoid data loss.</p> <p>The <i>back</i> icon is common to all T2S screens except for the <i>welcome</i> and <i>search</i> screens.</p>                  |
| 2            | <i>Print</i> icon | <p>... prints the data of the current screen.</p> <p>The printout includes the name of the printed screen, the date and the time of printing, the data access time, the name of the user who triggered the printing, the classification label 'Restricted' and the data available on the screen.</p> <p>It is strongly recommended to use this button for generating a clearly arranged overview of data on the printout.</p> |

| Position No. | Element             | Description   |
|--------------|---------------------|---|
|              |                     | <p>When printing a <i>list</i> screen on your standard printer, the whole list and search criteria are printed instead of only the part of the table visible on the screen.</p> <p>If you print an <i>edit</i> screen with data that have already been modified, the printout has the remark 'Changed Data'.</p> <p>If you print a <i>new</i> screen with data that have already been entered, the printout has the remark 'Not Stored Yet'.</p> <p>The <i>print</i> icon is common to all T2S screens except for the <i>welcome</i> screen.</p>  |
|              | <i>Export icon</i>  | <p>... exports the data of the executed query from the current screen into a csv-file.</p> <p>Leading and trailing space-characters adjacent to comma field separators are to be ignored.</p> <p>If exporting a list, the related search criteria are exported as well whereas detailed data are only exported, if the respective <i>list</i> and the <i>details</i> screen are covered by the same query. Otherwise just the list entry will be exported.</p> <p>The <i>export</i> icon is common to all T2S screens except for the <i>welcome</i> and the <i>new</i> screens.</p> <p>In addition to the exported data from the screen the following information is exported at the start of the file: name of the exported screen (including menu path), current date, name of the user who triggered the exporting, classification label 'RESTRICTED', defined search criteria (query parameters, if applicable), 'CHANGED DATA' when exporting an <i>edit</i> screen which contains amended data that has not been submitted yet.</p> |
|              | <i>Refresh icon</i> | <p>... reloads the screen.</p> <p>In new and edit modes the screen is locked, so it is not possible to refresh.</p> <p>The refresh function takes into account the search criteria that were chosen the last time the <i>search</i> button was clicked. Those search criteria will be displayed again.</p> <p>Changes that have not yet been saved are lost after using the <i>refresh</i> icon.</p>  |

| Position No. | Element              | Description   |
|--------------|----------------------|---|
|              |                      | The <i>refresh</i> icon is common to all T2S screens except for the <i>welcome</i> screen.  |
| 3            | <i>Collapse</i> icon | ... hides/displays the frame.<br>When first entering a screen, all frames are shown but can be hidden according to your preference by using the <i>collapse</i> icon. |

Utility  
Elements

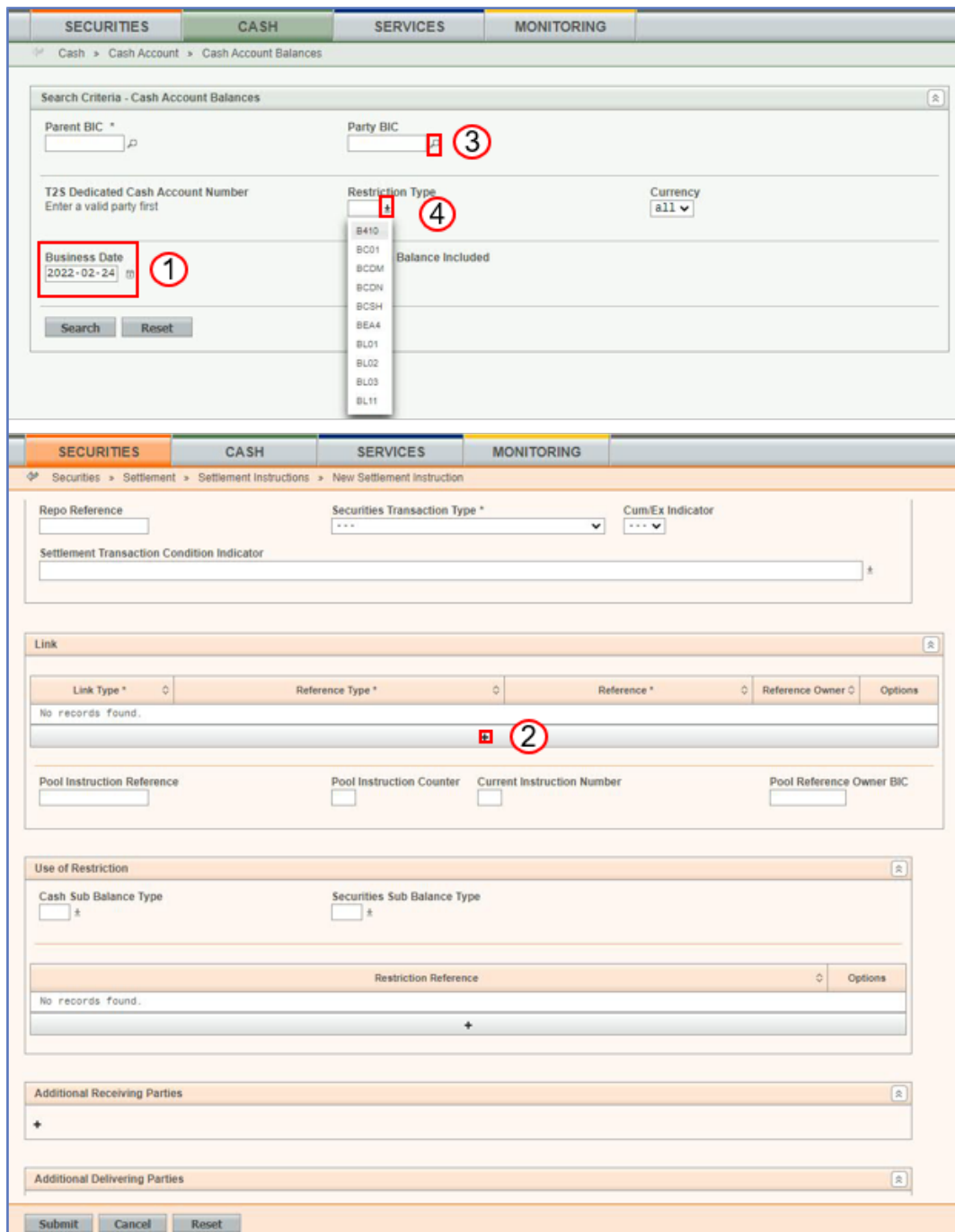

Illustration 13: Utility elements

| Position No. | Element       | Description  |
|--------------|---------------|--|
| 1            | Calendar icon | ... opens a calendar where you can select a day. If applicable, you can also select the time via the <i>calendar</i> icon. |
| 2            | Add row icon  | ... adds an empty row to the corresponding list.   |

| Position No. | Element                              | Description  |
|--------------|--------------------------------------|--|
|              |                                      | <p>The <i>add row</i> icon is only available on <i>new</i> and <i>edit</i> screens.</p> <p>You can insert a maximum of 10 rows at a time.</p>  |
| 3            | <i>Magnifier icon</i>                | <p>... provides the possibility to search for data on other screens.</p> <p>If you are not aware of the exact/correct value, but you know other related data, click on the <i>magnifier</i> icon to enter the <i>search</i> screen. There you can enter all information known to you and execute a search. By clicking on the <i>select</i> button, you are redirected to the initial screen with the desired data entered in the respective fields.</p> <p>The attribute equipped with magnifier icon works otherwise like an auto-complete select box.</p> |
| 4            | <i>Auto-complete select box icon</i> | <p>...provides you the possibility to use the auto-complete functionality, while the drop-down menu opens when clicking on it.</p> <p>You can select one of the provided entries, when clicking on an entry in the list.</p>   |

**Table Elements**

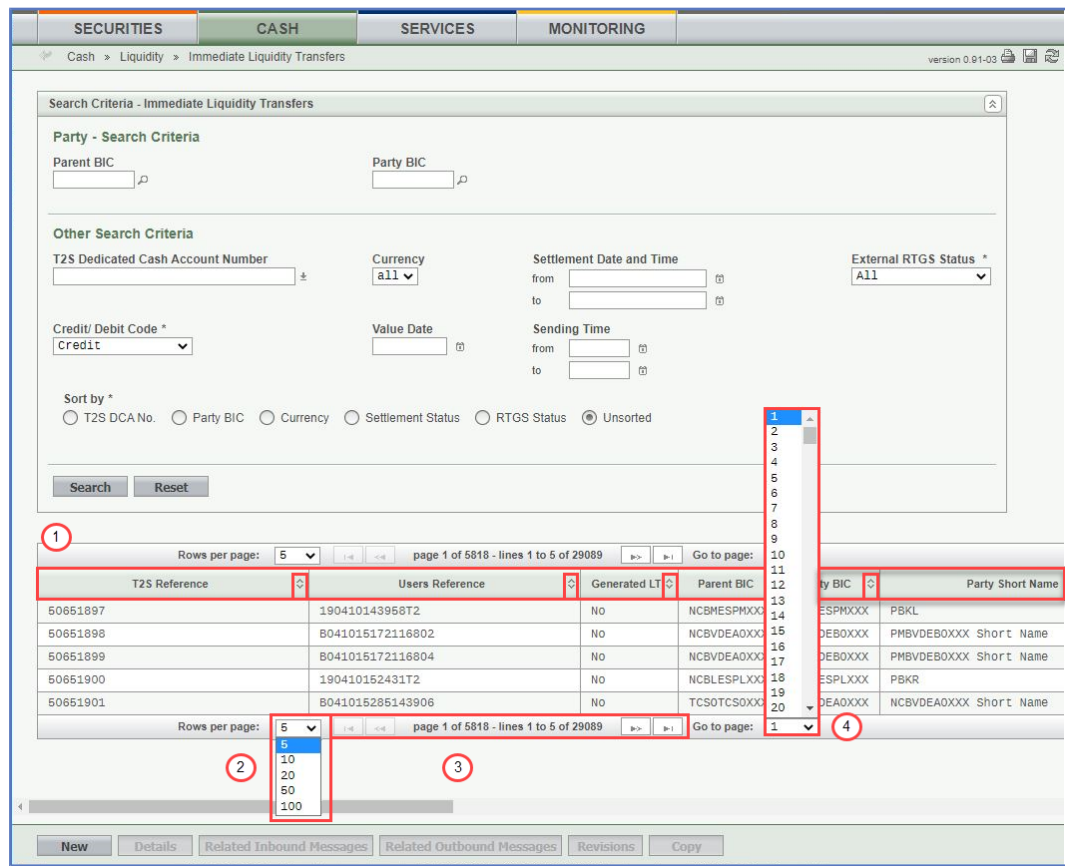

Illustration 14: Table elements

| Position No. | Element                | Description  |
|--------------|------------------------|--|
| 1            | Sort icon              | ... sorts the list in ascending or descending order by clicking on the up or down arrow.   |
| 2            | Number of data records | ... allows you to select the number of records displayed in the list. You can choose between 5, 10, 20, 50 or 100 data records to be displayed. The default number of data records to be displayed is 100. |
| 3            | First icon             | ... displays the first page of the list.   |
|              | Previous icon          | ... allows you to navigate through the displayed list and takes you to the previous page.  |
|              | Next icon              | ... allows you to navigate through the displayed list and takes you to the following page.   |
|              | Last icon              | ... displays the last page of the list.  |
| 4            | Number of table pages  | ... allows you to select the table page number you would like to go to.  |

## 1.2.3 Validation

In T2S, all submission processes undergo various validations, which take place in the front-end and/or in the back-end. Only correct entries, fulfilling all predefined criteria, can be further processed. To indicate the status of the recently performed action, T2S uses two different types of messages to indicate a successful or failed validation as described below.

In addition to the automatic validation carried out by T2S, human validation can be imposed by using the 4-eyes mode.

Furthermore, non-repudiation of origin (NRO) is implemented for a specified number of screens.

### Front-End Validation

As first part of the validation process, the front-end validation takes place without communication to the back-end. The front-end validation includes both the field validation and the cross-field validation. It is carried out after clicking on a button.

The field validation verifies that all entries comply with the required format.

The cross-field validation checks the data consistency between two or more fields/buttons in relation to each other.

### Confirmation Prompt

In the case of business actions in 2-eyes mode, a confirmation prompt is shown after successful front-end validation to give you the opportunity to submit or reject the business action. This confirmation prompt does not appear in 4-eyes mode.

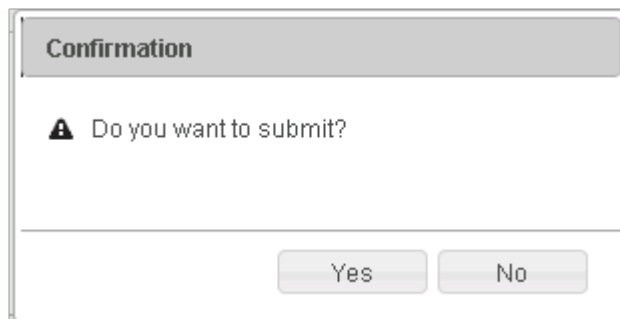

Illustration 15: Confirmation prompt

### Back-End Validation

The back-end validation is the second part of the validation process. After successful front-end validation, your request is submitted to the back-end and checked for compliance with the business validation rules. In case of failure an error message is displayed. You can find a detailed list of all error messages and their description in the annex of the UHB (list of references for error messages [▶ 921]).

### Result

After each validation, the T2S GUI informs you about the result. There are two different message types available, the **error message** and the **success message**.



### Error Message

Each error message is marked with a circle symbol and appears at the top of the content area and next to the field containing the error. In the case of a failed front-end or back-end validation, it indicates the source of the failure, the type of error and a short hint. This message is also shown as mouse-over text when you move the mouse cursor over the circle symbol next to the respective input field.

In case a Settlement Instruction or Settlement Restriction fulfils a rejection restriction type one positive rule, the error message provided in the GUI will also contain the relevant rule id fulfilled, the restriction type name and its description, in addition to the relevant error message applicable as described in the error messages annex of the UHB (list of references for error messages).

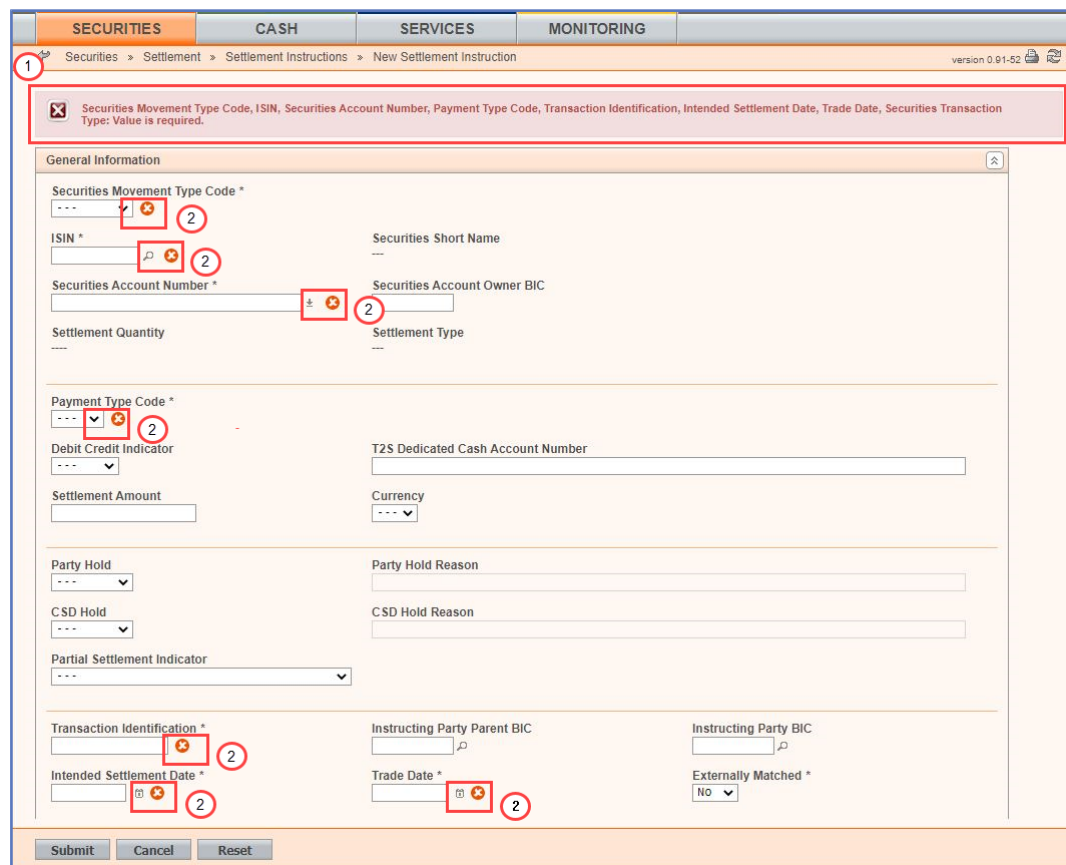

Illustration 16: Error message

| Position No. | Description                  |
|--------------|------------------------------|
| 1            | Type of error and short hint |
| 2            | Source of the failure        |

### Success Message

The success message appears in a green frame at the top of the content area. It confirms that your data have been submitted successfully.

In case a Settlement Instruction fulfils a CSD validation hold restriction type one positive rule, the success message provided in the GUI will also contain the relevant rule id fulfilled, the restriction type name and its description, in addition to the relevant error message applicable as described in the error messages annex of the UHB (list of references for error messages).

If the Settlement Instruction fulfils a rejection and/or CSD validation hold restriction type one negative rule, the success message provided in the GUI will also contain the relevant rule id fulfilled, the restriction type name and its description. The same applies in case a Settlement Restriction fulfils a rejection restriction type one negative rule.

If you are working in 4-eyes mode, the success message also provides you with the 4-eyes principle ID. This identification number helps you to search for the respective transaction via the *data changes – search/list* screen [▶ 607].

The screenshot displays the T2S GUI interface for an Immediate Liquidity Transfer. At the top, there are navigation tabs: SECURITIES, CASH, SERVICES, STATIC DATA, and MONITORING. The breadcrumb trail indicates the path: Cash > Liquidity > Immediate Liquidity Transfers > Immediate Liquidity Transfer – New. A green success message box is highlighted with a red border, containing the following text: "Success Message", "Your data have successfully been submitted.", "Your request was entered in 4-Eyes principle and a second user is needed to confirm.", "Please find the 4-Eyes principle ID below:", and "123456". Below the message, the form for the transfer is visible, with fields for Debit Cash Account, Liquidity Transfer, and Credit Cash Account. The Debit Cash Account section includes a dropdown for "T2S Dedicated Cash Account Number" (123456789) and a text field for "T2S Dedicated Cash Account Owner" (UNGCIT21XXX). The Liquidity Transfer section includes a text field for "User Reference" (User Reference 1) and a text field for "Amount" (11,002.32 EUR). The Credit Cash Account section includes radio buttons for "Outbound Liquidity Transfer" and "Internal Liquidity Transfer", and a text field for "External RTGS Account Number" (11223496745) and a dropdown for "T2S Dedicated Cash Account Number" (---). At the bottom of the form are buttons for "Submit", "Cancel", and "Reset".

Illustration 17: Success message

### Queued Message

If you are submitting a static data request outside real-time settlement, your request could be queued. In this case, instead of the above mentioned success message the following message is shown: 'Your request has been queued successfully and will be resumed after the end of the current night-time settlement sequence'.

**4-Eyes Mode** Depending on the access rights setup, you can use T2S in 2-eyes or in 4-eyes mode. The 2-eyes mode and the 4-eyes mode apply for *enter* screens (new and edit mode) and for any kind of deletion processes. If you are a 4-eyes mode user, your actions have to be confirmed by a second user in order to be processed.

#### First User

In 4-eyes mode the first user enters, changes or deletes the data on a screen and afterwards submits the action by clicking on the *submit* button in the button bar. The success message appearing after successful validation includes a 4-eyes principle ID. For the final execution a second user is needed to confirm the action.

#### Second User

After the first user has entered, changed or deleted the data, a second user (with the required privilege) has to approve or revoke this action via the *data changes* screen [▶ 607] either using the 4-eyes mode ID or the search functionality.

An *alert* icon is shown on the active T2S screen for those users with appropriate privileges to approve a pending action via the *data changes* screen. By clicking on the *alert* icon you are directed to the *data changes - search/list* screen [▶ 607] where you can first search and then approve/revoke the pending changes.



#### Hint

Ask the first user for the 4-eyes principle ID and use it to limit the number of search results on the *data changes – search/list* screen.

As soon as the data changes are positively approved, T2S marks these data as approved and they are forwarded to further processing.

#### Digital Signature – NRO

In order to ensure non-repudiation of origin (NRO) for critical transactions, the use of a digital signature has been implemented for specified screens. This means that the user will be asked to enter a PIN code for signature purposes whenever an instruction is initiated. **The certificate used for digital signature must be linked to the logical “user” logged in T2S.{CR-810}**. With the entry of the PIN, T2S attaches a digital signature to the instruction entered by the T2S actor.

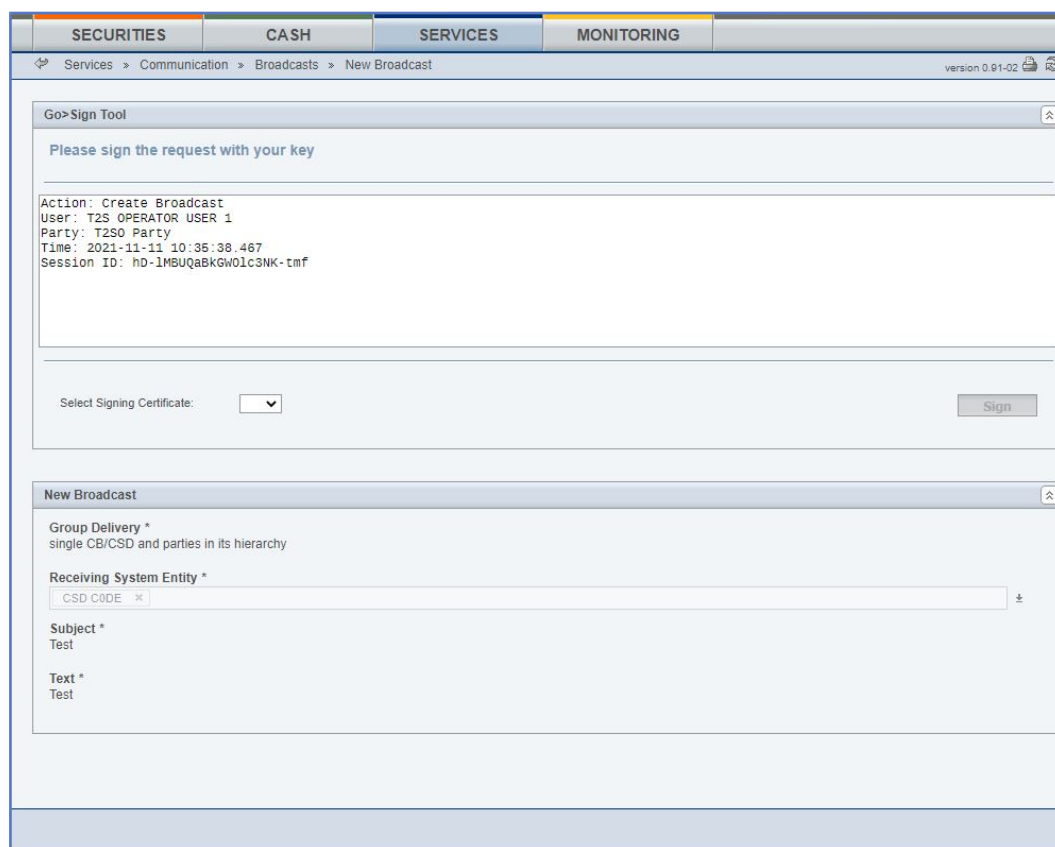

Illustration 18: Digital signature

The following (exhaustive) list provides an overview of screens for which the NRO feature is implemented:

- Amendment cash instruction - new screen* [▶ 409]
- Amendment securities instruction - new screen* [▶ 102]
- Broadcast - new screen* [▶ 621]
- Cancellation cash instruction - new screen* [▶ 419]
- Cancellation securities instruction - new screen* [▶ 116]
- Data change – details screen* [▶ 611]
- Hold/release instruction - new screen* [▶ 125]
- Immediate liquidity transfer order - new screen* [▶ 386]
- Intra-balance movement - new screen* [▶ 436]
- Intra-position movement - new screen* [▶ 150]
- Penalty – details screen* [▶ 290]
- Penalty - re-allocation screen* [▶ 317]
- Penalty - removal screen* [▶ 314]
- Penalty - switch screen* [▶ 321]
- Settlement instruction - new screen* [▶ 210]

## 1.2.4 Communication Network and Services

Refer to the T2S Connectivity Guide document for details on the communication network and services.

## 1.2.5 User Administration

### Registration

Only registered users have access to the T2S GUI, therefore registration in T2S reference data and to the network is necessary prior to the first GUI access. The Registration Guide for User Testing provides information on how to fill in T2S Registration Forms properly, e.g. access rights or white labelling.

After registration the system administrator is given the possibility to grant and revoke privileges to its users within the T2S GUI as described in both the screen reference part and the user instructions part.

## 1.2.6 Security and Certification Service

In order to guarantee a secure and safe handling of the information and to protect customer data provided via the GUI, various security elements have been put into place:

- Each action requires system or human validation as described in the validation [▶ 48]
- The scope of available data and functions is controlled via the management of access rights
- The security features provided by the network providers and described in their respective user documentation prevent unauthorised access

## 1.2.7 Online Help

The content of the UHB can be accessed from the T2S GUI by clicking on the *help* button. The online help is context sensitive, which means that the screen description corresponding to the current screen is displayed. Other parts of the online help can be reached using the table of contents on the left side of the help window.

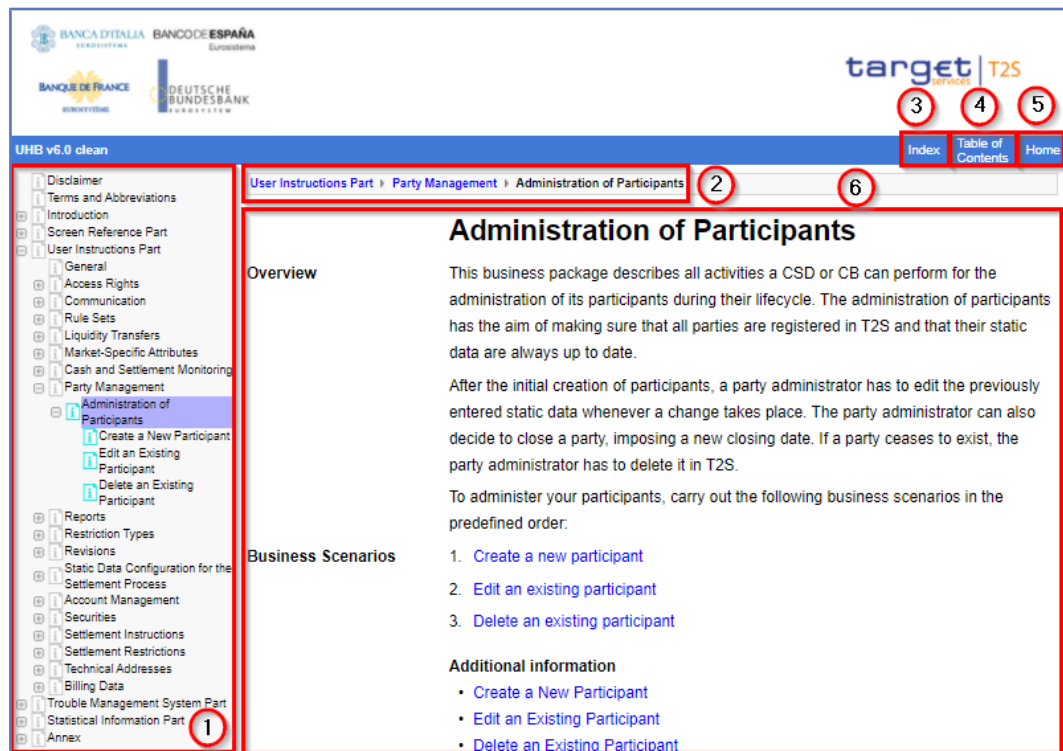

Illustration 19: Online help screen for 'Administration of Participants' business package.

| Position No. | Description   |
|--------------|---|
| 1            | Structure tree showing the table of contents, providing access to all handbook sections |
| 2            | Clickable breadcrumb  |
| 3            | <i>Index</i> button leading to the online help index                                    |
| 4            | <i>Table of contents</i> button leading to the online help table of contents            |
| 5            | <i>Home</i> button leading to online help welcome screen                                |
| 6            | <i>Help</i> screen content  |

### 1.3 Overview of the Graphical User Interface for CoCo GUI

The following sections refers to CRDM but the same structure can be considered valid for other common components.

The GUI is a browser-based application for communication with CRDM in U2A mode. It is based on the ISO norm 9241 'Ergonomics of human system interaction'.

### 1.3.1 Setup and Login Procedures

Before entering the GUI, make sure that your workstation complies with the hardware and software requirements and implement all necessary preparations (e.g. firewall settings) described below.

Such requirements/preparations may be subject to periodical review/update to comply with changing technical/regulatory scenario.

Common components are accessed entering the ESMIG Portal and selecting the proper common components under the service T2S.

**Hardware Requirements**

Please refer to ESMIG qualified configurations document.

**Software Requirements**

Please refer to ESMIG qualified configurations document.

**Supported Web-Browsers and Settings**

Please refer to ESMIG qualified configurations document.

**GUI Access**

Users are directed to an initial page named ESMIG portal that ensures proper routing to the web applications the user has been granted to enter.

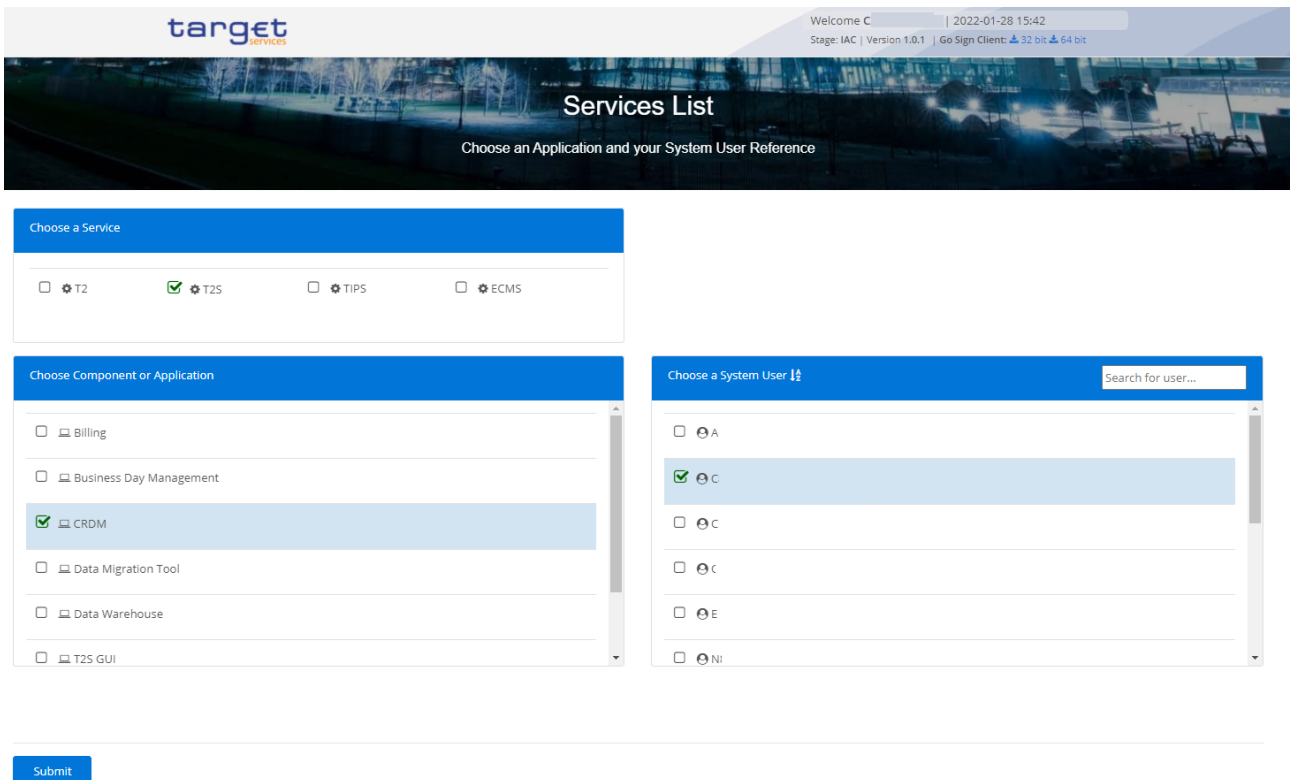

Illustration 20: ESMIG Portal

The ESMIG Portal screen expects the user to select the relevant service to enter **based also on the type of Party. For CSD and CSD Participant only T2S service is present.** {CR-805}

After the selection of the Service, the user is invited to select a specific component or application.

As a third step, once the component or application is selected, the user is requested to select the System User.

After submitting the screen, the user is redirected to the selected component or application.

In order to properly access the EMIG PORTAL and to select service and components, the user must be granted with the relevant privileges:

- T2S Access: the user granted with this privileges can see “T2S” under “Choose a Service” section and “T2S GUI” under “Choose Component or Application” section.
- CRDM\_Access: the user granted with this privileges can see “CRDM” under “Choose Component or Application” section.
- BILL\_Access: the user granted with this privileges can see “Billing” under “Choose Component or Application” section.
- BDM\_Access: the user granted with this privileges can see “Business Day Management” under “Choose Component or Application” section.
- DMT\_Access: the user granted with this privileges can see “Data Migration Tool” under “Choose Component or Application” section.
- TMS\_Access: the user granted with this privileges can see “TMS” under “Choose Component or Application” section.
- ORT\_Access: the user granted with this privileges can see “Operational Reporting Tools” under “Choose Component or Application” section.

### NRO specific requirements

Please refer to ESMIG qualified configurations document.

## 1.3.2 GUI Structure

This chapter explains the basic elements of the CRDM GUI structure (i.e. structure of the menu and the screens) helping you to navigate through the system and to use it quickly and efficiently.

The first subsection describes the menu structure where screens are grouped hierarchically. Afterwards, the second subsection explains the layout structure common to each screen. The following subsections provide details on the different Screen Types [▶ 59] and on recurring elements, such as common Field Types [▶ 60] or Buttons and Icons [▶ 67].



### 1.3.2.1 Menu Structure

The GUI menu is structured into four hierarchical menu levels. The hamburger menu appears when the proper icon is selected. After the first level is presented, it is possible to choose the functionalities that are common to the shared services and those that are specific for T2 or TIPS. Then the menu can be further navigated - the second, third and fourth menu levels are accessible via mouse-over on the first-level menu item - in order to select the desired functionality.



#### Hint

All the menu entries are visible to all users. Anyway, depending on your access rights, it is possible that not all menu entries are available for you. Contact your system administrator to verify that you have the necessary privileges to access all screens relevant to you. The privileges are listed in each screen and business scenario description.

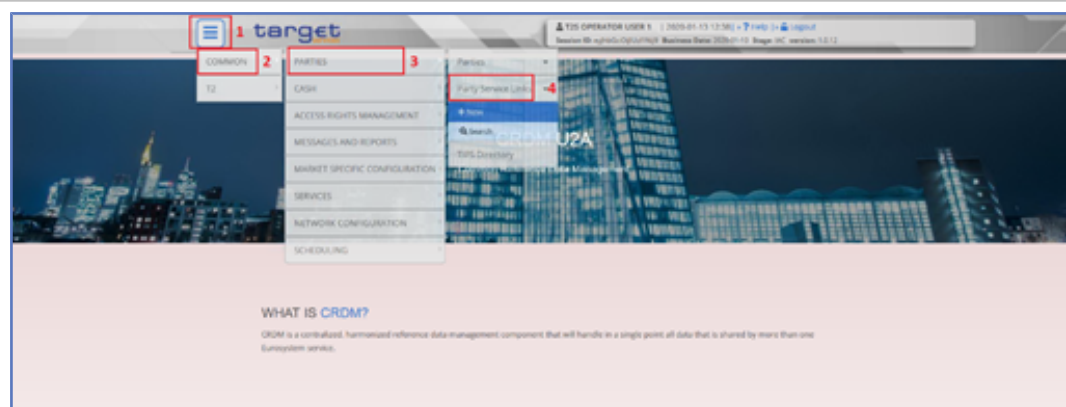

Illustration 21: CRDM menu levels

| Position No. | Description  |
|--------------|--------------|
| 1            | Menu level 1 |
| 2            | Menu level 2 |
| 3            | Menu level 3 |
| 4            | Menu level 4 |

All entries on the third menu level are structural subcategories. To access a screen you have to click on the fourth menu level.

### 1.3.2.2 Screen Structure

In general, each screen of the CRDM GUI follows the same layout containing a header and a content area.

The header appears at the top of every screen. It contains three main elements providing useful information and helping you to navigate between the different screens as shown in the illustration below.

**Header**

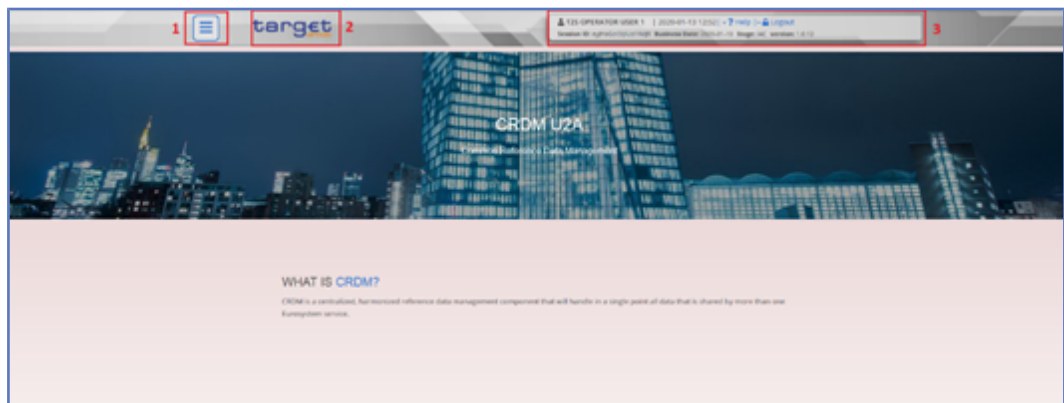

Illustration 22: Header elements

| Position No. | Element           | Description   |
|--------------|-------------------|---|
| 1            | Menu bar          | ... presents the main menu item and allows you to navigate to the screens.                              |
| 2            | CRDM logo button  | ... links to the welcome screen.  |
| 3            | Information panel | ... displays your login name, the logout and help buttons as well as date and time of last data access. |

**Content Area**

The content area is the part of the GUI where you can trigger all business actions. It is organised by five main elements which help you to interact properly with the GUI as shown in the illustration below.

To structure large amounts of data, the content area is further separated into frames and sub-frames.

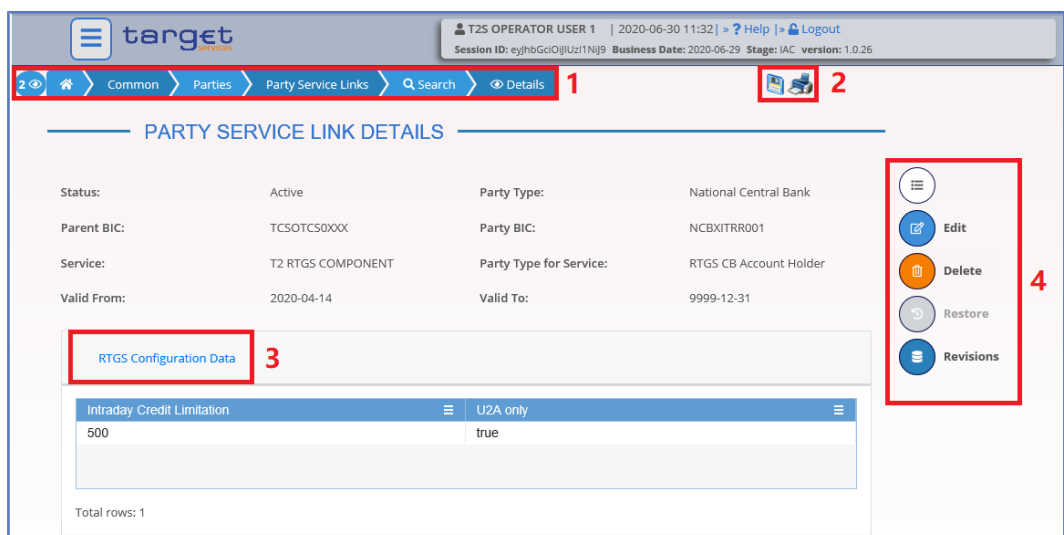

Illustration 23: Content area elements

| Position No. | Element    | Description                                    |
|--------------|------------|--|
| 1            | Breadcrumb | ... shows the main path to the current screen. |

| Position No. | Element                   | Description  |
|--------------|---------------------------|--|
| 2            | Basic icons               | ... exports or prints the screen content.                |
| 3            | Frame and sub-frame title | ... groups related information as a structural function. |
| 4            | Button bar                | ... shows all available buttons for the current screen.  |

Further information about the icons can be found in the common buttons and icons section.

### 1.3.2.3 Screen Types

The CRDM GUI consists of the following types of screens, each with a different function:

- Welcome screen
- Search/List screen
- Details screen
- Enter screen (usually new or edit screen)

#### **Welcome Screen**

Business scenarios are divided into single action steps. These action steps are numbered sequentially. Intermediate results are described where appropriate and marked with an indented arrow. Each business scenario ends with a final result, indicated by an arrow.

#### **Search/List Screen**

You can access all search/list screens on menu level four.

The search/list screen allows you to query the CRDM database using a pre-defined set of search criteria. After executing a search, a list of data records matching your search criteria is displayed in a table. To select an entry from a list displayed on a search/list or list screen, click on the desired entry. The background colour of the table line changes to indicate the selected entry. If the search retrieves only one record, the details screen is displayed directly, if you are authorised to access the details screen, else the record is displayed in the table in the list screen. You can browse through the list using the table buttons. Furthermore, it is possible to arrange your search results in ascending or descending order by the columns shown. This does not trigger a refreshed query.

#### **Details Screen**

In contrast to the search/list screen, you can only access the details screens via other screens.

All details screens provide you with in-depth information of a previously selected data record.

Before showing the details screen, a new query is forwarded to the system to ensure most up-to-date data.

**Enter Screen** Similar to the details screens, you can only access the enter screens through other screens.

Enter screens allow you to enter data, which can be done in two enter modes:

- New mode, represented by the new screens
- Edit mode, represented by the edit screens

In general, both modes contain the same fields. In the case of the new mode, all fields are blank. In the case of the edit mode, existing data are prefilled in the fields. In addition, one past value is reported (if available) which cannot be edited. You can edit the existing currently valid value by changing the content of the field. You can only edit an existing currently valid value provided that there is no future value. Otherwise, you need to delete the existing future value beforehand. You can also enter a new future value by clicking on the pencil icon.

### 1.3.2.4 Field Types and Properties

**Field Types** The description of the common field types with the proper descriptions follow.

**Input Fields** In input fields you can enter text and/or numeric content. Make sure to comply with the format requirements, which are part of each field/screen description.

Input-sensitive fields are input fields with an auto-complete mode that helps you to input data. As soon as you start typing the first characters of the respective data into an input-sensitive field, CRDM automatically proposes possible matching entries from which you can select the desired one.

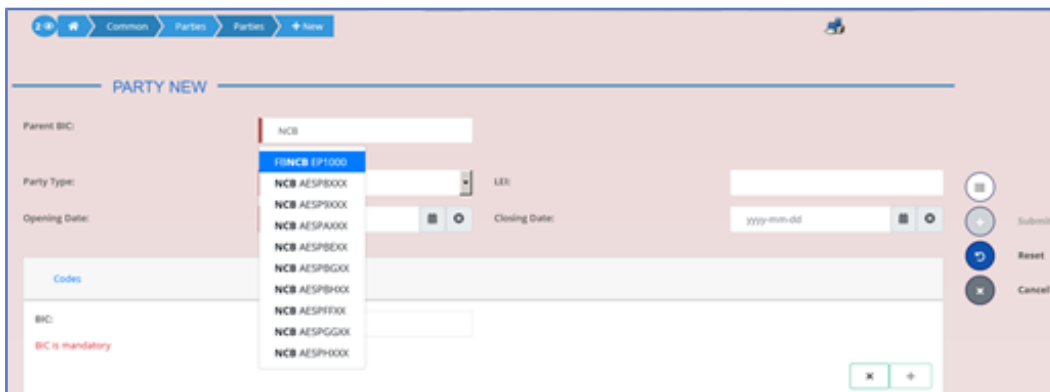

Illustration 24: Input-sensitive field



#### Hint

You can use the tab key on your keyboard to navigate through the GUI fields.

BIC8 that are entered via GUI are automatically supplemented to BIC11 by adding 'XXX' in order to unambiguously identify a party.

**Select Fields** Select fields are either select boxes, radio buttons or check boxes.

- **Select boxes:** Functionally a select box is a way to enter data from a limited list of possible values. In CRDM you can find different types of select boxes, standard select box, input-sensitive select box and auto-complete select box.
- **The standard select box** enables the user to choose one entry from a pre-defined set of values. To select an entry, click on the little box with the arrow to open the menu. Then select the desired value by clicking on it.

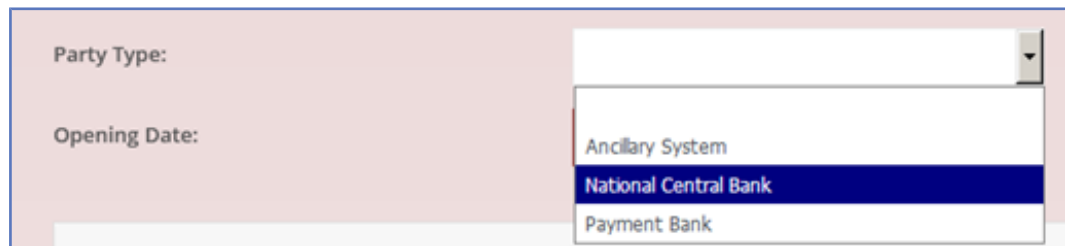

Illustration 25: Standard select box

- **The input-sensitive select box** enables the user to enter the desired value manually, which will be used to reduce the possible set of values in the input-sensitive select box list, which provides you with a drop-down menu that shows the 10 first entries of the set of values irrespective of what you might have entered in the text field.

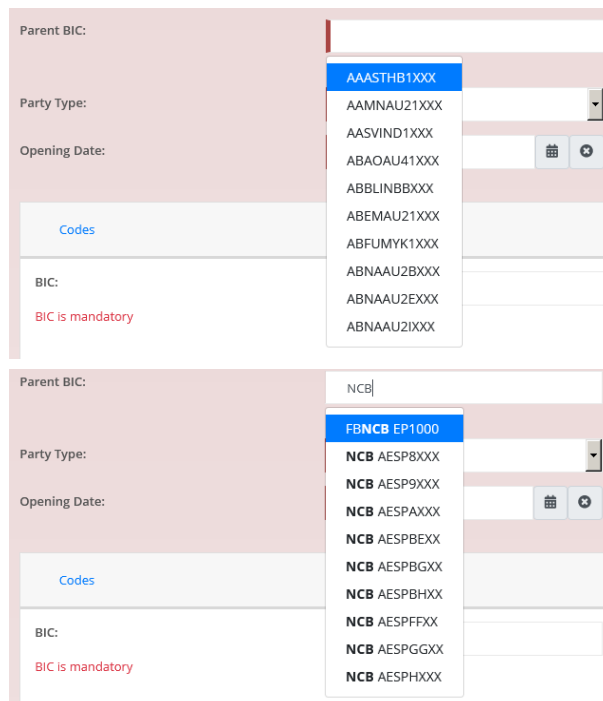

Illustration 26: Input-sensitive select box using the input-sensitive select box icon and input-sensitive select box with manually entered values.

- **The auto-complete select box** enables the user, differently from the input-sensitive select box, to make entries and choose values outside the standard set of values to be sent to the back-end for further validation (extended data scope). Due to that possibility of transporting unqualified data the validation of

the values is restricted to basic checks and will be carried out mainly in the backend. Apart from that, the auto-complete select box functions similar to the input-sensitive select box.

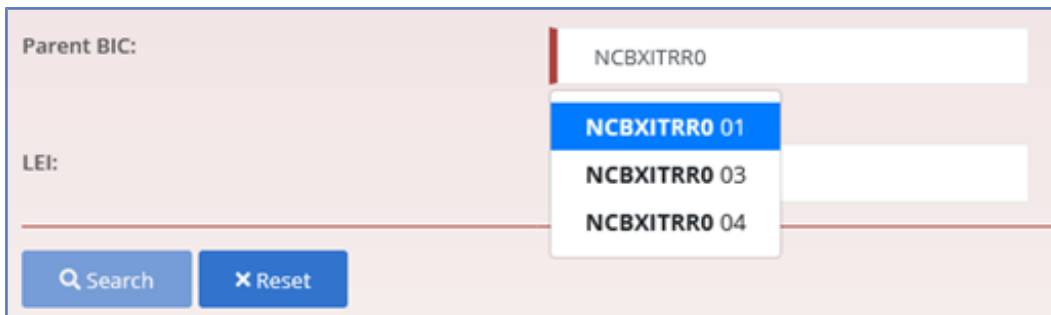

Illustration 27: Auto-complete select box

- Radio buttons:** Enable the user to make exact selections using one value from a set of options. You can select only one value at the same time. Click on the icon corresponding to the option you would like to select.

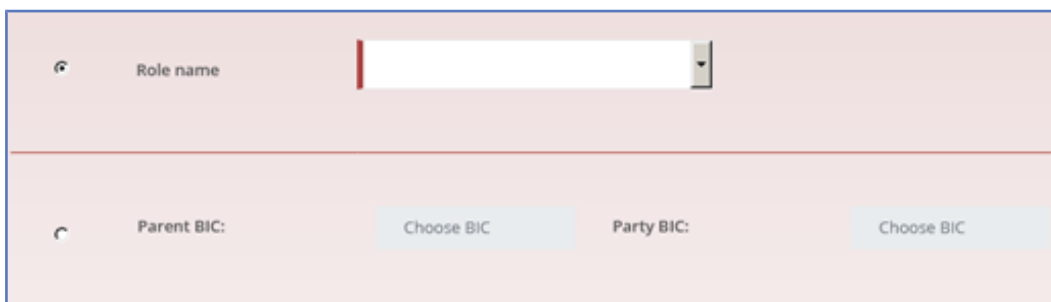

Illustration 28: Radio buttons

- Check boxes:** Enable you to select more than one value at the same time. Click on the boxes corresponding to the options you would like to select. Selected check boxes contain a check mark.

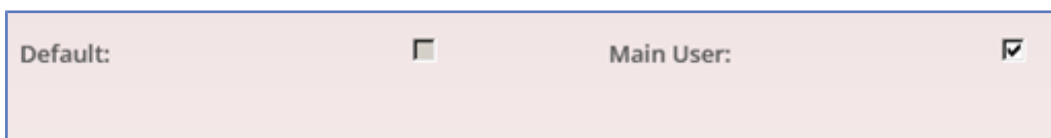

Illustration 29: Check boxes

## Wildcards

A wildcard is a placeholder for characters and it represents any acceptable character or a set of them in a string. In CRDM you can use a wildcard in input fields or google-style fields in all the search screens to search for data widening the result to all the strings matching the pattern. The required number of characters is indicated in the field description. CRDM accepts two possible values:

- '\*' that is a placeholder for one or more characters of the input value;
- '?' that is a placeholder for exactly one character of the input value.

### Examples

CRDM\*: The result list contains all data records beginning with 'CRDM'.

\*Account: The result list contains all data records ending with 'Account'.

CRD?: The result list contains all data records that have any acceptable character at the end of 'CRD', e.g. 'CRDM', 'CRDX', etc.

The combination of the wildcard '\*' is not possible, e.g. 'CRD?\*' or 'CR\*\*'

The wildcards are always usable in the fields reported before with the following restrictions:

- It is possible that to properly search with wildcards you have to insert at least two or four characters. In this case, the minimum number of characters to be entered is reported in the field remarks;
- It is possible that a field does not allow wildcards; in this case, this is explicitly mentioned in the Remarks field.

### **Read-only Fields**

In addition to enter and select fields, the CRDM GUI has also read-only fields, which are pre-filled and do not allow data changes.

### **Field Properties**

All field types have specific properties with respect to possible character sets, and mandatory content.

### **Date**

A Date type field has the following format: YYYY-MM-DD. There are four digits representing the year, two digits representing the month and two digits representing the day.

The default value of Date fields, unless differently specified, is BLANK.

Generally, if a closing date value is not specified, the system will automatically set the date "9999-12-31".

The field Date is always linked to a calendar icon that opens a calendar where you can select a day. It is possible to insert a date writing in the field or using the calendar.

### **Time <sup>1</sup>**

The Time type field has the following format: HH:MM. There are two digits representing the hour and two digits representing the minute.

### **DateTime <sup>2</sup>**

A DateTime type field has the following format: YYYY-MM-DD HH:MM. There are four digits representing the year, two digits representing the month, two digits representing the day, two digits representing the hour and two digits representing the minute. The field DateTime is always linked to a calendar icon that opens a calendar where you can select a day. It is possible to insert a date writing in the field or using the calendar.

### **Amount**

The GUI will show the amounts with all decimal points, English Format (the decimal separator will be a "." and the thousand separator is ",") and right alignment.

1 The Time in the system refers to the CET/CEST zone.

2 The Time in the system refers to the CET/CEST zone.

Amounts can be entered up to 18 figures, that is maximum 19 characters if the decimal separator is present.

When the amount field is in read-only mode or the amount field is not selected for typing, the amount shows the thousand separator.

When the user is typing the numbers, the amount is shown without the thousand separators.

The amount fields should allow shortcuts:

- enter "Xm" and the system will transfer this automatically into X,000,000.00[.00]
- enter "Yt" and automatically translated into Y,000[.00].

The number of decimals is defined by the currency.

Negative amounts (shown by the system but not entered by the user) are written in red and marked with a "-" (This rule applies for all negative values).

According to the character set, only numerical characters (decimal – abbreviation "d") can be used for amounts plus the negative symbol.

| Field   | Description                     | Validation  | Error Code   |
|---------|---------------------------------|---|--|
| Amounts | Contains an Amount.             | The Amount must be greater than or equal to 0.                              | The amount must be greater than or equal to 0.   |
| Amounts | Number of Decimals of an amount | The Amount must have <number of decimals stored for the currency> decimals. | Wrong format in field <field name>. The correct format has to be xxx.xxx,<number of decimals stored for the currency>. |
| Amounts | Character set to be used        | It is only possible to use a numerical character set.                       | Only numerical characters are allowed  |

## Numeric

There are different type of numeric field. In general these fields, in edit mode, can contain only numbers and "-" symbol.

| Field   | Description  | Edit mode                         | New mode  |
|---------|--|-----------------------------------|---|
| Numeric | Can contain only natural numbers (positive integer). | Only numbers are allowed.         | The thousand separator is shown.  |
| Integer | Can contain positive and negative integer values.    | Numbers and char "-" are allowed. | The thousand separator is shown. When negative, the char "-" is shown and the string is in red. |



| Field                 | Description   | Edit mode  | New mode  |
|-----------------------|---|--|---|
| Positive Real         | Can contain positive values with decimals. When using this type, the number of decimal must be specified.   | Numbers and decimal separator are allowed.           | The thousand and decimal separators are shown.  |
| Real                  | Can contain positive and negative values with decimals. When using this type, the number of decimal must be specified.  | Numbers, decimal separator and char “-“ are allowed. | The thousand and decimal separators are shown. When negative, the char “-“ is shown and the string is in red.                 |
| Percentage            | Can contain positive values with decimals. When using this type, a maximum of 5 digit(s) including decimal point (thereof max. 2 decimal places and decimal point) are allowed. | Numbers and decimal separator are allowed.           | The thousand and decimal separators are shown plus “%” symbol.  |
| Percentage + negative | Can contain positive and negative values with decimals. When using this type, the number of decimal must be specified.  | Numbers, decimal separator and char “-“ are allowed. | The thousand and decimal separators are shown plus “%” symbol. When negative, the char “-“ is shown and the string is in red. |
| Telephone Number      | Shall contain numbers from 0 to 9 and chars “+”, “-“, “(“, “)“.   | Numbers and chars “+”, “-“, “(“, “)” are allowed.    | The chars “+”, “-“, “(“, “)” are shown (e.g. ‘+012-3456789’).   |

| Field | Description  | Edit mode | New mode |
|-------|--|-----------|----------|
|       | <p>When using this type, the following pattern shall be respected:</p> <p>Starting with “+”</p> <p>Then at least one to maximum three digits</p> <p>Then symbol “-“</p> <p>Then at least one to maximum thirty characters (digits and symbols “+”, “-“, “(“, ”)“ are allowed).</p> |           |          |

## Characters

CRDM operates in British English and uses the SWIFT-x character set to enter data: if not described differently, the fields are intended to be based on the SWIFT-x character set. CRDM can accept the UTF-8 character set with the exception of '<', '>' and '&' in specific fields; when this happens, this is explicitly reported.

The GUI does not differentiate between upper and lower case in terms of data input for input fields.

The SWIFT-x character set corresponds with the following content:

| Character | Description                                 |
|-----------|---|
| a - z     | 26 small characters of the Latin alphabet   |
| A - Z     | 26 capital characters of the Latin alphabet |
| 0 - 9     | 10 numeric characters                       |
| /         | Solidus (slash)                             |
| -         | Hyphen                                      |
| ?         | Question mark                               |
| :         | Colon                                       |
| (         | Opening parenthesis                         |
| )         | Closing parenthesis                         |
| .         | Full stop                                   |
| ,         | Comma                                       |

| Character | Description     |
|-----------|-----------------|
| '         | Apostrophe      |
| +         | Plus            |
|           | Space (blank)   |
| CR        | Carriage return |
| LF        | Line feed       |



**Hint**

CRDM does not process fields (mandatory or optional), that are only filled with blanks. Blanks appearing at the beginning or at the end of a field entry are deleted automatically without any notification.

Fields in a list or details screen, where the dataset was saved without an entry, are filled with '---'.

**Mandatory Content**

In the GUI all mandatory fields are marked with a red line in the label. All marked fields have to be filled in before you are allowed to proceed. The red line is turned into green when the field contains a value or is selected.

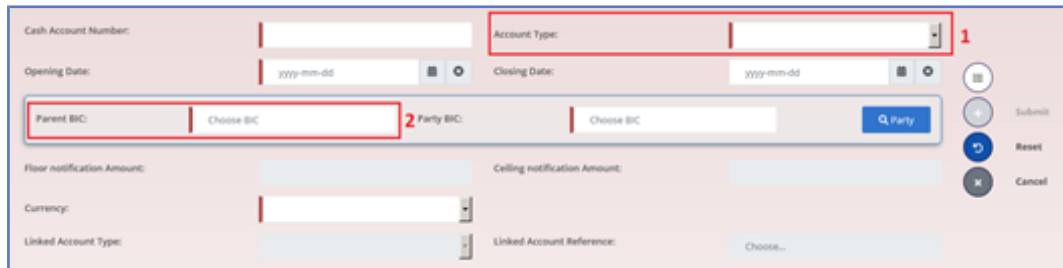

Illustration 30: Mandatory fields

| Position No. | Description            |
|--------------|------------------------|
| 1            | Mandatory select field |
| 2            | Mandatory input field  |

**1.3.2.5 Common Buttons and Icons**

While working with the CRDM GUI you will find that some buttons and icons appear regularly. There are three types of common elements:

- Basic icons, which you can find on every screen
- Utility elements, which represent functions within the content area
- Table elements, which you can find below data record lists on search/list

The buttons contained in the button bar are variable and therefore explained in the screen descriptions.

**Basic Icons**



Illustration 31: Basic icons

| Position No. | Element     | Description  |
|--------------|-------------|--|
| 1            | Export icon | <p>... exports the data of the executed query from the current screen into a csv-file.</p> <p>If exporting a list, the related search criteria are exported as well whereas detailed data are only exported, if the respective list and the details screen are covered by the same query. Otherwise just the list entry will be exported.</p> <p>The export icon is common to all CRDM screens except for the welcome and the new screens.</p> <p>In addition to the exported data from the screen the following information is exported at the start of the file: name of the exported screen (including menu path), current date, name of the user who triggered the exporting, classification label 'RESTRICTED', timestamp of the export, defined search criteria (query parameters, if applicable), 'CHANGED DATA' when exporting an edit screen which contains amended data that has not been submitted yet.</p> |
| 2            | Print icon  | <p>... prints the data of the current screen.</p> <p>It is strongly recommended to use this button for generating a clearly arranged overview of data on the printout.</p> <p>The print icon is common to all CRDM screens except for the welcome screen.</p>  |

## Utility Elements

**PARTY SERVICE LINK NEW**

Parent BIC: Choose BIC Party BIC: Choose BIC 6 Party

Service: T2 RTGS COMPONENT Party Type for service: Choose...

Valid From: yyyy-mm-dd 1 Valid To: yyyy-mm-dd

**RTGS Configuration Data**

Intraday Credit Limitation: U2A only:

Mandatory field

| Intraday Credit Limitation | U2A only |
|----------------------------|----------|
| No Rows To Show            |          |

Total rows: 0 2 3

---

**MESSAGE SUBSCRIPTION RULE SET DETAILS**

Status: Active Service: T2S

Rule Set Id: 20000741 Name: FES.STADV.CNF

Description: FES Receiving Status Advices and Confirmations Positive/Negative parameter set: Positive

Valid From: 2015-02-27 Valid To: 9999-12-31

Creator Parent BIC: TCSOTCS00XX Creator Party BIC: CSDAHUHB00X

**Interested Parties**

| Parent BIC  | Party BIC   |
|-------------|-------------|
| TCSOTCS00XX | CSDAHUHB00X |
| CSDAHUHB00X | PARBUHB00X  |
| CSDAHUHB00X | PARAHUHB00X |

Total rows: 10

**Rules**

Status: Active

| Status | Seq | Rule      | Valid From          | Valid To            | Rule Boolean Expression         |
|--------|-----|-----------|---------------------|---------------------|---------------------------------|
| Active | 2   | 200001643 | 2015-02-27 00:00:00 | 9999-12-31 00:00:00 | (Message Type = sese.025) as 25 |
| Active | 3   | 200001653 | 2015-02-27 00:00:00 | 9999-12-31 00:00:00 | (Message Type = camt.054) as 3  |
| Active | 4   | 200001644 | 2015-02-27 00:00:00 | 9999-12-31 00:00:00 | (Message Type = camt.066) as 4  |
| Active | 5   | 200001664 | 2015-02-27 00:00:00 | 9999-12-31 00:00:00 | (Message Type = camt.067) as 5  |
| Active | 6   | 200001645 | 2015-02-27 00:00:00 | 9999-12-31 00:00:00 | (Message Type = camt.068) as 6  |
| Active | 7   | 200001665 | 2015-02-27 00:00:00 | 9999-12-31 00:00:00 | (Message Type = camt.072) as 7  |

Total rows: 24 7

Revisions +Add Rule

Illustration 32: Utility Elements

| Position No. | Element       | Description   |
|--------------|---------------|---|
| 1            | Calendar icon | ... opens a calendar where you can select a day. If applicable, you can also select the time via the calendar icon. |

| Position No. | Element             | Description   |
|--------------|---------------------|---|
| 2            | Pencil icon         | <p>... enables you to enter a new future value into an input field.</p> <p>In edit mode, you can either change an existing data record or enter a new future one. If you have changed the existing current value before entering a future one, the data are restored.</p> <p>The pencil icon is only available on edit screens.</p>   |
| 3            | Delete row icon     | <p>... removes the selected row in the corresponding list as well as fields or sub-frames.</p> <p>The delete row icon is only available on new and edit screens.</p>  |
| 4            | Submit changes icon | <p>... updates the selected row in the corresponding list using the values inserted in the related fields.</p> <p>The submit changes icon is only available on new and edit screens.</p>  |
| 5            | Cancel changes icon | <p>... enables you to leave the selected and edited row without causing any changes.</p> <p>The cancel changes icon is only available on new and edit screens.</p>  |
| 6            | Magnifier icon      | <p>... provides the possibility to search for data on other screens.</p> <p>If you are not aware of the exact/correct value, but you know other related data, click on the magnifier icon to enter the search screen. There you can enter all information known to you and execute a search. By clicking on the select button, you are redirected to the initial screen with the desired data entered in the respective fields.</p> <p>The attribute equipped with magnifier icon works otherwise like an auto-complete select box.</p> |

| Position No. | Element                      | Description  |
|--------------|------------------------------|--|
| 7            | Heart icon, Restore row icon | ... restores the selected row in the corresponding list or sub-frames.<br><br>The Heart icon is only available on lists or sub-frames. |

**Table Elements**

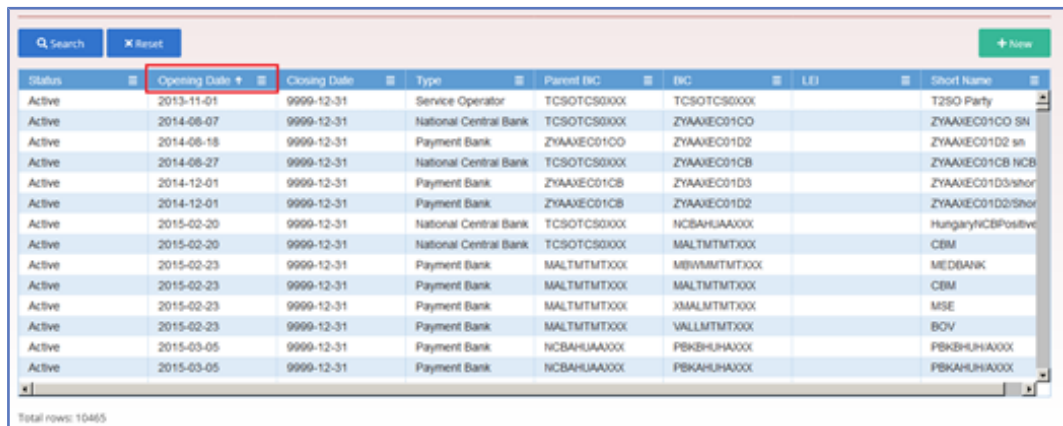

Illustration 33: Table Elements – Sort icon

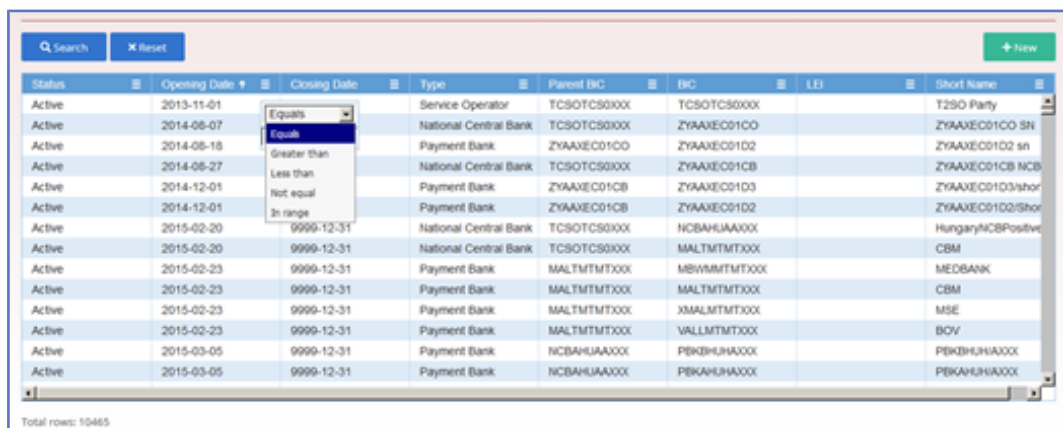
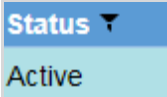

Illustration 34: Table Elements - Supplementary filters in list objects

| Position No. | Element              | Description  |
|--------------|----------------------|--|
| 1            | Sort icon            | ... sorts the list in ascending or descending order by clicking on the up or down arrow.   |
| 2            | Supplementary filter | ... allows in-memory filtering, depending on the type of fields, of the displayed list of items according to additional criteria as shown below.<br><br>Data fields supplementary filter criteria:<br><input type="checkbox"/> Equals<br><input type="checkbox"/> Greater than<br><input type="checkbox"/> Less than |

| Position No. | Element | Description   |
|--------------|---------|---|
|              |         | <p><input type="checkbox"/> Not equal</p> <p><input type="checkbox"/> In range</p> <p>Text fields supplementary filter criteria:</p> <p><input type="checkbox"/> Equals</p> <p><input type="checkbox"/> Not equal</p> <p><input type="checkbox"/> Starts with</p> <p><input type="checkbox"/> Ends with</p> <p><input type="checkbox"/> Contains</p> <p><input type="checkbox"/> Not contains</p> <p>Predefined supplementary filter criteria:</p> <p>It contains an adaptive list of values which is consistent with the related search criterion. E.g. for any Status field, the predefined supplementary filter contains the following values: 'All', 'Active', 'Deleted'.</p> <p>When a supplementary filter criterion is used, the list is automatically filtered in memory without submitting the query to the back-end. When applied, any supplementary filter can be removed by individually resetting the corresponding filter.</p> <p>If a supplementary filter is applied, a small icon near the column header is displayed, as shown in the following image.</p>  |

### 1.3.3 Validation

In CRDM, all submission processes undergo various validations, which take place in the front-end and/or in the back-end. Only correct entries, fulfilling all predefined criteria, can be further processed. To indicate the status of the recently performed action, CRDM uses two different types of messages to indicate a successful or failed validation as described below.



In addition to the automatic validation carried out by CRDM, human validation can be imposed by using the 4-eyes mode.

Furthermore, non-repudiation of origin (NRO) is implemented for a specified number of screens.

**Front-End Validation**

As first part of the validation process, the front-end validation takes place without communication to the back-end. The front-end validation includes both the field validation and the cross-field validation. It is carried out after clicking on a button.

The field validation verifies that all entries comply with the required format.

The cross-field validation checks the data consistency between two or more fields/buttons in relation to each other.

**Back-End Validation**

The back-end validation is the second part of the validation process. After successful front-end validation, your request is submitted to the back-end and checked for compliance with the business validation rules. In case of failure an error message is displayed. You can find a detailed list of all error messages and their description in the annex of the UHB (List of References for Error Messages [► 921]).

**Result**

After each validation, the CRDM GUI informs you about the result. There are two different message types available, the error message and the success message.

**Error Message**

Each error message appears as a pop-up on the upper right corner of the screen. In the case of a failed front-end or back-end validation, it indicates the source of the failure, the type of error and a short hint.

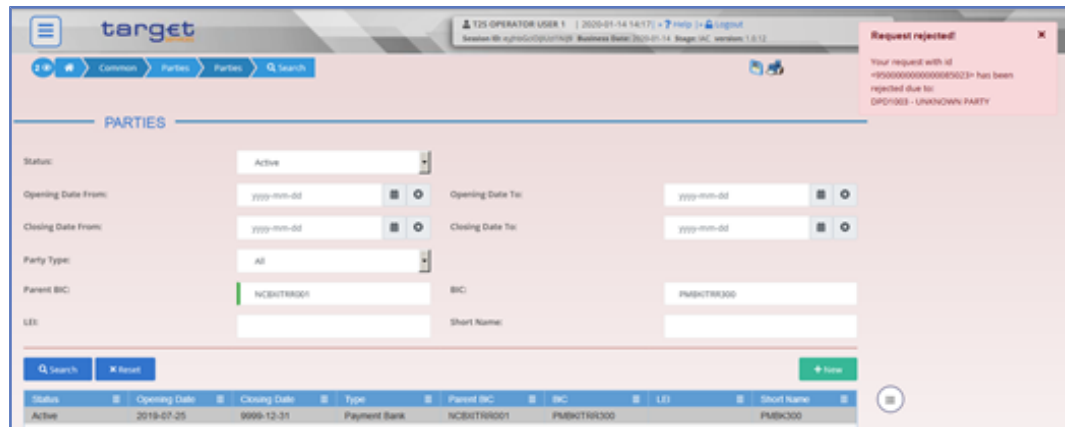

Illustration 35: Error message

**Success Message**

The success message appears as a pop-up on the upper right corner of the screen. It confirms that your data have been submitted successfully.

If you are working in 4-eyes mode, the success message also provides you with the 4-eyes principle ID.

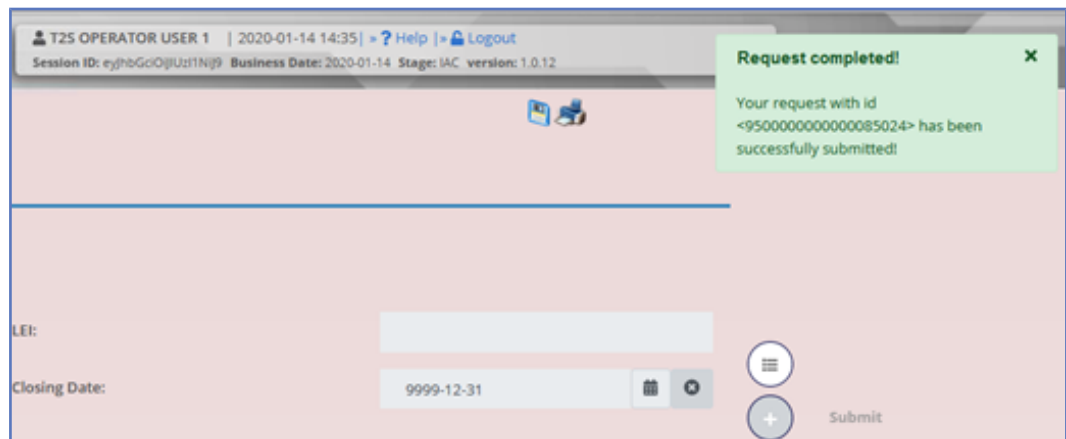

Illustration 36: Success message

**4-Eyes Mode** Depending on the access rights setup, you can use CRDM in 2-eyes or in 4-eyes mode. The 2-eyes mode and the 4-eyes mode apply for enter screens (new and edit mode) and for any kind of deletion processes. If you are a 4-eyes mode user, your actions have to be confirmed by a second user in order to be processed.

**First User** In 4-eyes mode the first user enters, changes or deletes the data on a screen and afterwards submits the action by clicking on the submit button in the button bar. The success message appearing after successful validation includes a 4-eyes principle ID. For the final execution a second user is needed to confirm the action.

**Second User** After the first user has entered, changed or deleted the data, a second user (with the required privilege) has to approve or revoke this action via the data changes screen either using the 4-eyes mode ID or the search functionality.

As soon as the data changes are positively approved, CRDM marks these data as approved and they are forwarded to further processing.

**Digital Signature NRO** For further information refer to chapter Digital Signature (NRO).

## 1.3.4 Communication Network and Services

Refer to the ESMIG UDFS document for details on the communication network and services.

## 1.3.5 User Administration

**Registration** Only registered users have access to the CRDM GUI, therefore registration in CRDM reference data and to the network is necessary prior to the first GUI access. The Registration Guide provides information on how to fill in Registration Forms properly.

After registration the system administrator is given the possibility to grant and revoke privileges to its users within the CRDM GUI as described in both the screen reference part and the user instructions part.

---

## 1.3.6 Security and Certification Services

In order to guarantee a secure and safe handling of the information and to protect customer data provided via the GUI, various security elements have been put into place:

- Each action requires System or human validation as described in the Validation [► 72]
- The scope of available data and functions is controlled via the management of access rights
- The security features provided by the network providers and described in their respective user documentation prevent unauthorised access

## 1.3.7 Online Help

The content of the UHB can be accessed from the CRDM GUI by clicking on the help button.

## 2 Screen Reference Part

### 2.1 General

The screen reference part offers a complete overview of all T2S GUI screens that are available in U2A mode. Each screen description focuses on a single screen and explains all fields contained therein. An exception is made for the *new* and *edit* screens, which are largely similar and therefore included in a single screen description. The description is always based on and contains only the screenshot of the *edit* screen, but describes deviations for the *new* screen in a separate row for each field or button description.

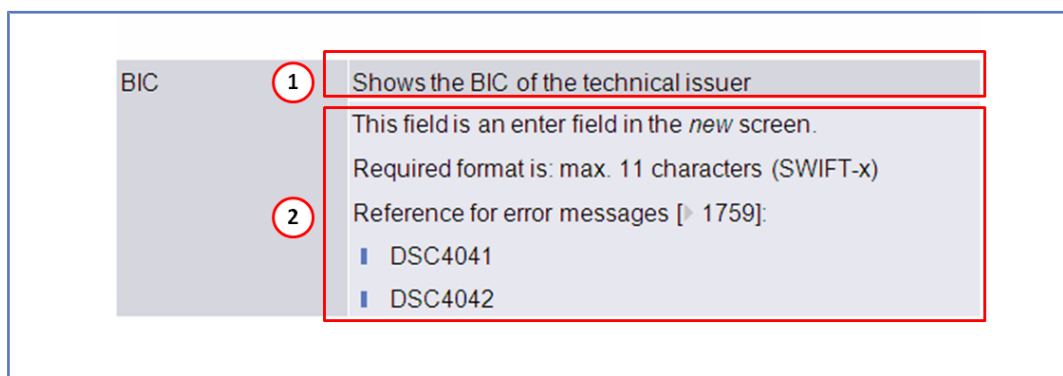

Illustration 37: Example of a *new* and *edit* screen description

| Position No. | Element                                    |
|--------------|--|
| 1            | Description relevant for <i>edit</i> mode. |
| 2            | Description relevant for <i>new</i> mode.  |

In detail, every screen description has the same structure and contains the following elements.

**Context of Usage**

The context of usage explains what a screen displays, what you can do with the screen and which special features are available for the screen, for example the need for confirmation in 4-eyes mode or usage restrictions. If the export functionality produces more data than shown on the screen (if a *list* screen is based on a detailed query), this is also indicated in the context of usage.

**Screen Access**

The screen access lists all possible ways to access the screen. This includes navigation via the menu and navigation via other screens.



### Examples

Navigation via the menu:

Common >> Cash >> Cash Accounts >> Search

Navigation via other screens:

Common >> Parties >> Parties >> *Parties – search/list* screen >> Click on the *search* and *details* button >> Click on the *cash accounts* button

---

When navigating via a *search/list* or *list* screens, a data record has to be selected by clicking on a table row. Afterwards, you can click on specific buttons in the button bar, e.g. the *edit* or *details* button.

### Privileges

The privileges segment lists all necessary privileges to access the screens and to use its functions. First, the privileges to access a screen are mentioned, followed by the privileges that are necessary to use all functions on the screen.

For further information, refer to the list of privileges.

### References

The first reference lists all business scenarios containing the respective screen (reference to the user instructions part). The second reference indicates the business functions related to the respective screen (reference to GUI Business Functionalities Document).

### Screenshot

You can use the screenshot as orientation for your work with the UHB. All screenshots are based on the maximum of access rights, so deviations are possible if you do not own all privileges which are necessary to use the screen in its full extent. In addition, deviations between the screenshot and the field/button description are possible in the case of mutually exclusive functions and based on a specific selection you have made. Values shown on the screenshot might also deviate from the default values indicated in the description.

In the case of the *new/edit* screen description, the screenshot of the *edit* screen is used. Differences appearing in the *new* screen are explained in the field description.

### Field

#### Description

The field description provides all the relevant information related to the respective field name. It is structured in table format with a separate table for each frame. Subframes are indicated by subsection headings in the table. The following illustration explains the structure of a field description.

| Field                   | 2 Amendment Instruction  |   |
|-------------------------|--------------------------|---|
| Description             | 3 Referenced Instruction |   |
| 1 Instructing Party BIC | 4                        | Enter the BIC of the instructing party for the instruction to be linked to.<br><br>5 Required format is: max. 11 characters (SWIFT-x)<br><br>6 If the "T2S Reference" field is not filled in, this field is mandatory.<br><br>7 Reference for error message: [ 1392]<br>■ MVDC026<br>■ MVCV107<br>■ MVCV232<br><br>8 This field is only available, if the referenced instruction is a settlement instruction. |

Illustration 38: Example of a screen description

| Position No. | Element           | Description   |
|--------------|-------------------|---|
| 1            | Field name        | ... indicates the respective name of each screen field.<br><br>Mandatory fields are marked with an asterisk after the field name. In the case of the <i>new/edit</i> screen description, the mandatory field is marked with an asterisk in brackets, which indicates that the respective field is either mandatory in the edit or in the new mode. Input and select fields without an asterisk are always optional. |
| 2            | Frame name        | ... indicates the respective name of each screen frame.   |
| 3            | Sub-frame name    | ... indicates the respective name of each screen sub-frame.   |
| 4            | Field description | ... indicates the field type and required content. Each field description starts with a keyword, which illustrates your required activity:<br><br><input type="checkbox"/> 'Shows...' indicates a read-only field [ 36]<br><br><input type="checkbox"/> 'Select...' indicates a select field [▶ 36]   |

| Position No. | Element                      | Description   |
|--------------|------------------------------|---|
|              |                              | <ul style="list-style-type: none"> <li>□ 'Enter...' indicates an input field [ ▶ 36]</li> </ul> <p>If there is an exhaustive list of possible values, these are listed.</p>   |
| 5            | Required/Displayed format    | <p>... indicates all field format requirements related to the fields. If there is more than 1 format requirement, they are separated with a comma.</p> <p>In read-only fields the displayed format is only mentioned, if the field content is ambiguous. This applies especially to date fields.</p> <p>The following keywords are used for the format requirements:</p> <ul style="list-style-type: none"> <li>□ 'Digit' indicates numbers</li> <li>□ 'Character' indicates a character from the SWIFT-x character set [ ▶ 36]</li> <li>□ 'Letter' indicates upper and lower case letters of the Latin alphabet</li> </ul> |
| 6            | Cross-field validations      | <p>... indicate interdependencies between fields relevant for the validation of your input.</p> <p>For further details on the validation process, refer to validation [ ▶ 48].</p>  |
| 7            | References for error message | <p>... indicates the code of all possible errors applying to the field during the back-end validation. The corresponding error text and error description is listed in the annex (list of references for error messages [ ▶ 921]).</p> <p>For further details on the validation process, refer to validation [ ▶ 48].</p>   |
| 8            | Additional information       | <p>... section indicates the useful information that is for filling in the field.</p>   |

## Buttons

All buttons specific to the screen are listed and described in a table at the end of the screen description. The following illustration explains the structure of a button description.

**Buttons**

|          |        |  |
|----------|--------|--|
| <b>1</b> | Search | <p><b>2</b> This function enables you to start a search according to the criteria entered. The results are displayed in a list on the same screen.</p> <p><b>3</b> Next screen:<br/> <ul style="list-style-type: none"> <li>■ Roles – search/list screen</li> </ul> </p> <p><b>4</b> If the deletion status of the selected role is already set to “Active”, this function is not available.</p> <p><b>5</b> Reference for error messages: [ ▶ 1702]<br/> <ul style="list-style-type: none"> <li>■ DRR6001</li> <li>■ DRR6002</li> </ul> </p> <p><b>6</b> If you have accessed this screen via another screen, this function is not available.</p> |
|----------|--------|--|

Illustration 39: Example of a button description

| Position No. | Element                       | Description  |
|--------------|-------------------------------|--|
| 1            | Button name                   | ... indicates the respective name of each button.  |
| 2            | Button description            | ... indicates the action that is triggered when clicking on the button. Each button description starts with ‘This function enables you...’   |
| 3            | Next screen                   | ... element lists the screen which is displayed after clicking on a button. If there are various possible next screens depending on your previous actions, all of them are listed.   |
| 4            | Cross-field validations       | ... indicate interdependencies between a field and the button relevant for the validation of your input.<br><br>For further details on the validation process, refer to validation [ ▶ 48].                                      |
| 5            | References for error messages | ... indicates the code of all possible errors applying to the button during the back-end validation. The corresponding error text and error description is listed in the annex (list of references for error messages [ ▶ 921]). |



| Position No. | Element                | Description  |
|--------------|------------------------|--|
|              |                        | For further details on the validation process, refer to validation [▶ 48].         |
| 6            | Additional information | ... section indicates useful information regarding the button and/or its function. |

For further information on common buttons, refer to Common Buttons and Icons [▶ 42].

## 2.2 Securities

### 2.2.1 Securities Account

#### 2.2.1.1 Securities Positions - Search/List Screen

See *Securities Positions – Search/List Screen* [▶ 168].

#### 2.2.1.2 Securities Position - Details Screen

See *Securities Positions – Details Screen* [▶ 173].

#### 2.2.1.3 Securities Postings - Search/List Screen

#### Context of Usage

This screen contains a number of search fields. By inputting the relevant data, you can search for securities postings, which are the individual debits and credits impacting the selected securities positions. The search results are displayed in a list, which is sorted by the values of the 'Securities Account Number' column in ascending order (default setting). After selecting an entry, you can proceed further by clicking the buttons below.

This screen is not relevant for CB users.

#### Screen Access

- Securities >> Securities Account >> Securities Postings
- Securities >> Securities Account >> Securities Positions >> *Securities positions – search/list* screen >> Click on the *search* and/or *details* button >> *Securities position - details* screen >> Click on the *postings* button
- Securities >> Settlement >> Securities Positions >> *Securities positions – search/list* screen >> Click on the *search* and/or *details* button >> *Securities position - details* screen >> Click on the *postings* button
- Monitoring >> Monitoring >> Securities Positions >> *Securities positions – search/list* screen >> Click on the *search* and/or *details* button >> *Securities position - details* screen >> Click on the *postings* button

- Securities >> Settlement >> Intra-position Movements >> *Intra-position movement – details* screen >> Click on the *securities position details* button >> >> *Securities position - details* screen >> Click on the *postings* button

**Privileges**

To use this screen, you need the following privilege [▶ 897]:

- Securities posting query

**References**

**User Instructions Part**

This screen is part of the following business scenario:

- View current securities positions and related postings [▶ 681]

**Business Functionality Document**

This screen corresponds to the following business functions:

- Query securities account postings (T2S.GUI.SESE.POS.0030)
- Display securities account postings (T2S.GUI.SESE.POS.0040)

**Screenshot**

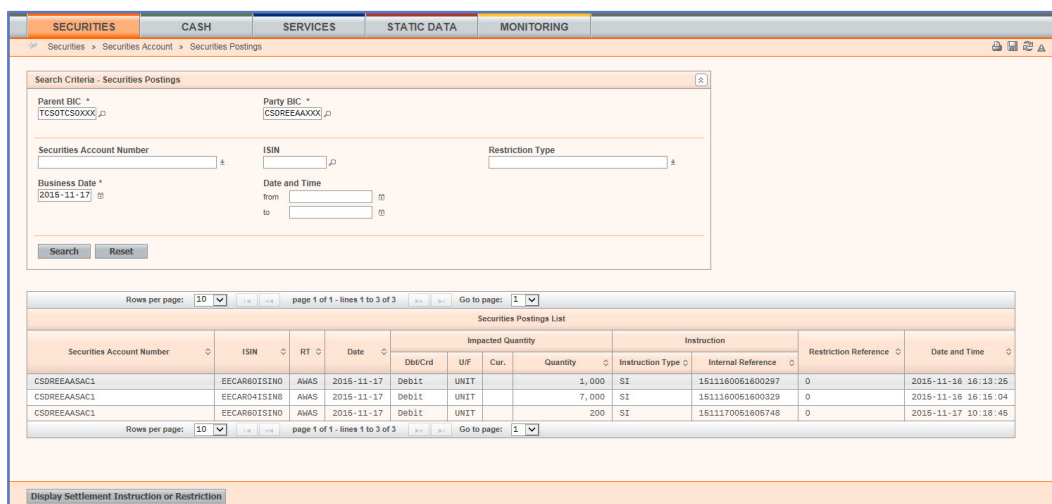

Illustration 40: Securities postings – search/list screen

**Field Description**

| Securities Postings – Search Criteria |  |
|---------------------------------------|--|
| Parent BIC*                           | Select the BIC of the CSD from the drop-down menu.<br>Required format is: max. 11 characters (SWIFT-x)<br>If you have accessed this screen via the securities positions – details screen, this field is already filled in.   |
| Party BIC*                            | Select the BIC of the party from the drop-down menu.<br>Required format is: max. 11 characters (SWIFT-x)<br>If you have accessed this screen via the securities positions – details screen, this field is already filled in. |
| Securities Account Number             | Select the number of the securities account from the drop-down menu.   |

| Securities Postings – Search Criteria |  |
|---------------------------------------|--|
|                                       | <p>Required format is: max. 35 characters (SWIFT-x)</p> <p>No default value but filled if only one account possible.</p> <p>If you have accessed this screen via the securities positions – details screen, this field is already filled in.</p> <p>Reference for error message:</p> <p><input type="checkbox"/> QMPC030</p>   |
| ISIN                                  | <p>Enter the ISIN of the security.</p> <p>Required format is: 12 characters (SWIFT-x)</p> <p>Must be a valid existing ISIN.</p> <p>If you have accessed this screen via the securities positions – details screen, this field is already filled in.</p>  |
| Restriction Type                      | <p>Select the restriction type from the drop-down menu.</p> <p>Required format is: max. 4 characters (SWIFT-x)</p> <p>Value 'All' defined as postings of all securities positions.</p> <p>If you have accessed this screen via the securities positions – details screen, this field is already filled in.</p>   |
| Date                                  | <p>Enter the date of the securities postings or use the <i>calendar</i> icon.</p> <p>Required format is: YYYY-MM-DD</p> <p>The default value is the current business day.</p> <p>This date must be a valid business date earlier than or equal to the current business date.</p> <p>If you have accessed this screen via the securities positions – details screen, this field is already filled in.</p> |
| Date and Time from                    | <p>Enter the starting date and time of the securities postings or use the <i>calendar</i> icon.</p> <p>Required format is: YYYY-MM-DD HH:MM</p> <p>This date and time must be a valid business date earlier than or equal to the current business date and time.</p>   |
| Date and Time to                      | <p>Enter the ending date and time of the securities postings or use the <i>calendar</i> icon.</p> <p>Required format is: YYYY-MM-DD HH:MM</p>  |

| <b>Securities Postings – Search Criteria</b> |   |
|--|---|
|  | This date and time must be a valid business date earlier than or equal to the current business date and time. The date and time must be equal or later than the 'Date and Time From'.                             |
| <b>Securities Postings - List</b>            |   |
| Securities Account Number                    | Shows the number of the securities account of the securities posting.<br>Reference for error message:<br><input type="checkbox"/> QMPC030   |
| ISIN   | Shows the ISIN of the security.   |
| Restriction Type                             | Shows the restriction type of the securities posting.   |
| Date   | Shows the date of the last movement of the securities posting.<br>Displayed format is: YYYY-MM-DD   |
| <b>Quantity Impacted</b>                     |   |
| Debit/Credit Indicator                       | Shows the debit credit indicator related to the securities posting from one of the possible values:<br><input type="checkbox"/> D (for debit)<br><input type="checkbox"/> C (for credit)                          |
| Settlement Type                              | Shows the quantity type related to the securities posting from one of the possible values:<br><input type="checkbox"/> U (for unit)<br><input type="checkbox"/> F (for face amount)                               |
| Currency                                     | Shows the issuance currency of the security related to the securities posting.<br>Provided only when quantity of securities is given as a face amount.  |
| Quantity                                     | Shows the quantity of the securities posting.   |
| <b>Instruction</b>                           |   |
| Instruction Type                             | Shows the type of instruction related to the securities posting from the possible values:<br><input type="checkbox"/> SI (for settlement instruction)<br><input type="checkbox"/> SR (for settlement restriction) |
| Internal Reference                           | Shows the identification of the T2S internal reference of the instruction related to the securities posting.  |

| Securities Postings – Search Criteria |   |
|---------------------------------------|---|
| Restriction Reference                 | Shows the identification of the restriction reference related to the securities posting.                  |
| Date and Time                         | Shows the date and time of the securities posting.<br>Displayed format is: YYYY-MM-DD hh:mm:ss:µsµsµsµsµs |

**Buttons**

| Buttons                                       |  |
|---|--|
| Search  | This function enables you to start a search according to the criteria entered. The results are displayed in a list on the same screen.<br>Next screen:<br><input type="checkbox"/> <i>Securities postings – search/list</i> screen<br>Reference for error message:<br><input type="checkbox"/> QMPC030     |
| Reset   | This function enables you to set default search criteria and blanks out all optional criteria.<br>Next screen:<br><input type="checkbox"/> <i>Securities postings – search/list</i> screen   |
| Display Settlement Instruction or Restriction | This function enables you to display the details of the securities instruction or restriction for the selected row.<br>Next screen:<br><input type="checkbox"/> <i>Settlement instruction - details</i> screen [▶ 191]<br><input type="checkbox"/> <i>Intra-position movement – details</i> screen [▶ 143] |

### 2.2.1.4 Securities Restriction Details - Search/List Screen

**Context of Usage**

This screen contains a number of search fields. By inputting the relevant data, you can search for securities restrictions which are sub positions reserved, blocked or earmarked for specific purpose. The search results will be displayed in a list, which is sorted by the value of the ‘Securities Account Number’ column in ascending order (default setting). After selecting an entry, you can further proceed by clicking on the buttons below.

During the Start of Day, when the CRDM data is being replicated in the Settlement domain, only the securities restrictions data available at the End-of-Day of the previous business day is displayed on the screen. The securities restrictions data for the new business day is available as of the end of the CRDM data replication.

During night-time, the securities restriction details can only be displayed in-between night-time settlement sequences.

This screen is not relevant for CB users.

**Screen Access**

- Securities >> Securities Account >> Securities Restriction
- Securities >> Securities Account >> Securities Positions >> *Securities positions – search/list* screen >> Click on the *search* and/or *details* button >> *Securities position - details* screen >> Click on the *restriction reference* button

**Privileges**

To use this screen, you need the following privilege [▶ 898]:

- Securities position detailed restriction details query

**References**

**User Instructions Part**

This screen is part of the following business scenario:

- View current securities positions and related restrictions [▶ 682]

**Business Functionality Document**

This screen corresponds to the following business functions:

- Display securities account positions (T2S.GUI.SESE.POS.0020)
- Query securities account positions – current and history (T2S.GUI.SESE.POS.0010)

**Screenshot**

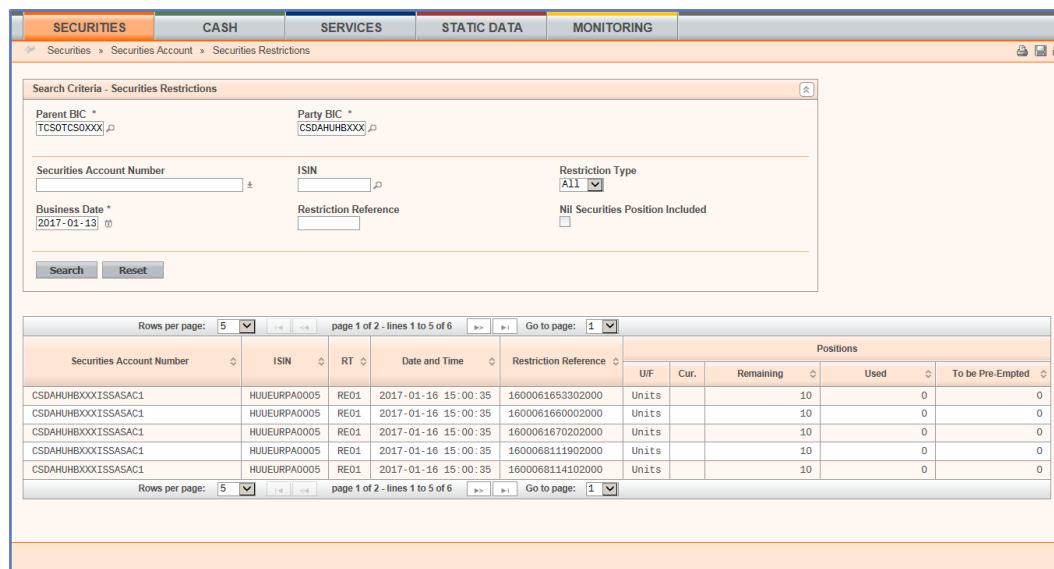

Illustration 41: Securities restriction details – search/list screen

**Field Description**

| Securities Restriction Details – Search Criteria |  |
|--|--|
| Party BIC*                                       | Select the BIC of the party from the drop-down menu or search via the <i>magnifier</i> icon.<br><br>Reference for error message: |

| Securities Restriction Details – Search Criteria |  |
|--|--|
|  | <input type="checkbox"/> QMPC032   |
| Parent BIC*                                      | Select the parent BIC of the party from the drop-down menu.<br>Reference for error message:<br><input type="checkbox"/> QMPC048  |
| Securities Account Number                        | Select the number of the securities account from the drop-down menu.<br>This field is already filled in, if there is only one possible account.<br>Reference for error message:<br><input type="checkbox"/> QMPC030  |
| ISIN   | Enter the ISIN of the security.<br>Required format is: max. 12 characters (SWIFT-x)  |
| Restriction Type                                 | Select the restriction type from the drop-down menu. The default value is 'All'.<br>Reference for error message:<br><input type="checkbox"/> QMPC091   |
| Date   | Enter the date of the movement related to the restricted securities position or use the <i>calendar</i> icon. The default value is the current business day.<br>Required format is: YYYY-MM-DD<br>The 'Date' must be a valid business date earlier than or equal to the current business date. |
| Restriction Reference                            | Enter the restriction reference.<br>Required format is: max. 16 characters (SWIFT-x)   |
| Nil Securities Position included                 | Select if you want to include securities positions without securities.   |
| Securities Restriction Details - List            |  |
| Securities Account Number                        | Shows the number of the securities account of the securities restriction.<br>Reference for error message:<br><input type="checkbox"/> QMPC030  |
| ISIN   | Shows the ISIN of the security.  |
| Restriction Type                                 | Shows the restriction type of the securities restriction.  |

| Securities Restriction Details – Search Criteria |  |
|--|--|
|  | Reference for error message:<br><input type="checkbox"/> QMPC091   |
| Date and Time                                    | Shows the date and time of the balance or the closest previous date.<br><br>Displayed format is: YYYY-MM-DD hh:mm:ss:µsµsµsµsµs                    |
| Restriction Reference                            | Shows the restriction reference of the securities restriction.   |
| Positions  |  |
| Settlement Type                                  | Shows the quantity type related to the securities from the possible values:<br><br><input type="checkbox"/> Units<br><input type="checkbox"/> Face |
| Currency   | Shows the issuance currency of the security when the quantity type of the securities is set to 'F' (face amount).                                  |
| Remaining  | Shows the quantity of the remaining securities restrictions.   |
| Used   | Shows the quantity of the utilised securities restrictions.  |
| To be Pre-Empted                                 | Shows the quantity of the securities restrictions to be pre-empted.  |

**Buttons**

| Buttons |   |
|---------|---|
| Search  | This function enables you to start a search according to the criteria entered. The results are displayed in a list on the same screen.<br><br>Next screen:<br><input type="checkbox"/> <i>Securities restriction details – search/list</i> screen<br><br>References for error messages:<br><input type="checkbox"/> QMPC030<br><input type="checkbox"/> QMPC032<br><input type="checkbox"/> QMPC048<br><input type="checkbox"/> QMPC091 |
| Reset   | This function enables you to set default search criteria and blanks out all optional criteria.<br><br>Next screen:<br><input type="checkbox"/> <i>Securities restriction details – search/list</i> screen   |



## 2.2.2 Settlement

### 2.2.2.1 Allegement Instructions - Search/List Screen

|                         |  |
|-------------------------|--|
| <b>Context of Usage</b> | <p>This screen contains a number of search fields. By inputting the relevant data, you can search for allegement instructions. The search results will be displayed in a list, which is sorted by the values of the 'Allegement Identification' column in ascending order (default setting). After selecting an entry, you can proceed further by clicking on the buttons below.</p> <p>When exporting the content of this screen, you receive the list and the corresponding details for each data record.</p> <p>This screen is not relevant for CB users.</p> <p>This function is only available in U2A mode.</p> |
| <b>Screen Access</b>    | <ul style="list-style-type: none"><li>□ Securities &gt;&gt; Settlement &gt;&gt; Settlement Instruction Allegements</li></ul>   |
| <b>Privileges</b>       | <p>To use this screen you need the following privilege [▶ 866]:</p> <ul style="list-style-type: none"><li>□ Allegement query</li></ul>   |
| <b>References</b>       | <p><b>User Instructions Part</b></p> <p>This screen is part of the following business scenarios:</p> <ul style="list-style-type: none"><li>□ Respond to an allegement instruction [▶ 696]</li><li>□ View allegement settlement instruction details [▶ 702]</li></ul> <p><b>Business Functionality Document</b></p> <p>This screen corresponds to the following business functions:</p> <ul style="list-style-type: none"><li>□ Query allegements (T2S.GUI.SESE.ALG.0010)</li><li>□ Display allegement list (T2S.GUI.SESE.ALG.0020)</li></ul>   |

Screenshot

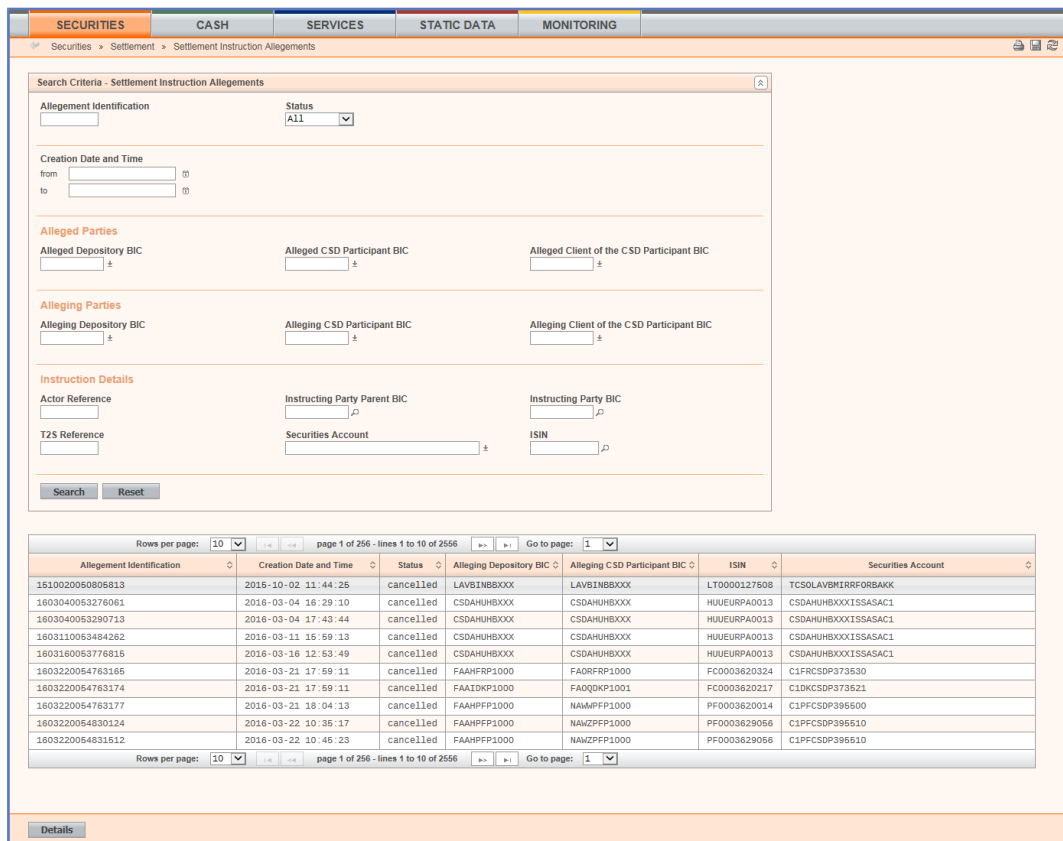

Illustration 42: Allegement instructions - search/list screen

Field Description

| Settlement Instruction Allegement – Search Criteria |  |
|---|--|
| Allegement Identification                           | Enter the unique identification of the allegation.<br>Required format is: max. 16 characters (SWIFT-x)   |
| Status  | Select the status of the allegation from the possible values:<br><br><input type="checkbox"/> Sent<br><input type="checkbox"/> Removed<br><input type="checkbox"/> Cancelled<br><input type="checkbox"/> All (default value)   |
| Creation Date and Time from                         | Enter the lower bound of the search range for the date and time from which the allegation was created or use the <i>calendar</i> icon.<br><br>Required format is: YYYY-MM-DD hh:mm:ss<br>Reference for error message [ 927]:<br><br><input type="checkbox"/> QMPC015 |
| Creation Date and Time to                           | Enter the upper bound of the search range for the date and time until which the allegation was created or use the <i>calendar</i> icon.  |

| Settlement Instruction Allegement – Search Criteria |   |
|---|---|
|   | <p>Required format is: YYYY-MM-DD hh:mm:ss</p> <p>Reference for error message [ 927]:</p> <p><input type="checkbox"/> QMPC015</p>   |
| Alleged Parties                                     |   |
| Alleged Depository BIC                              | <p>You can choose to either enter the BIC of the alleged depository or to select it from the suggested items in the drop-down menu.</p> <p>Required format is: max. 11 characters (SWIFT-x)</p>                     |
| Alleged CSD Participant BIC                         | <p>You can choose to either enter the BIC of the alleged CSD participant or to select it from the suggested items in the drop-down menu.</p> <p>Required format is: max. 11 characters (SWIFT-x)</p>                |
| Alleged Client of the CSD Participant BIC           | <p>You can choose to either enter the BIC of the alleged client of the CSD participant or to select it from the suggested items in the drop-down menu.</p> <p>Required format is: max. 11 characters (SWIFT-x)</p>  |
| Alleging Parties                                    |   |
| Alleging Depository BIC                             | <p>You can choose to either enter the BIC of the alleging depository or to select it from the suggested items in the drop-down menu.</p> <p>Required format is: max. 11 characters (SWIFT-x)</p>                    |
| Alleging CSD Participant BIC                        | <p>You can choose to either enter the BIC of the alleging CSD participant or to select it from the suggested items in the drop-down menu.</p> <p>Required format is: max. 11 characters (SWIFT-x)</p>               |
| Alleging Client of the CSD Participant BIC          | <p>You can choose to either enter the BIC of the alleging client of the CSD participant or to select it from the suggested items in the drop-down menu.</p> <p>Required format is: max. 11 characters (SWIFT-x)</p> |
| Instruction Details                                 |   |
| Actor Reference                                     | <p>Enter the identification of the settlement instruction assigned by the T2S actor.</p> <p>Required format is: max. 16 characters (SWIFT-x)</p>  |

| Settlement Instruction Allegement – Search Criteria |  |
|---|--|
| Instructing Party BIC                               | You can choose to either enter the BIC of the instructing party or to select it from the suggested items in the drop-down menu.<br><br>Required format is: max. 11 characters (SWIFT-x)  |
| Instructing Party Parent BIC                        | You can choose to either enter the parent BIC of the instructing party or to select it from the suggested items in the drop-down menu.<br><br>Required format is: max. 11 characters (SWIFT-x)   |
| T2S Reference                                       | Enter the identification of the settlement instruction assigned by T2S.<br><br>Required format is: max. 16 characters (SWIFT-x)  |
| ISIN  | Select the ISIN of the security from the drop-down menu.   |
| Securities Account                                  | You can choose to either enter the securities account number or to select it from the suggested items in the drop-down menu.<br><br>For a RECE SI the securities account number is the securities account of the delivering party. For a DELI SI the securities account number is the securities account of the receiving party.<br><br>Required format is: max. 35 characters (SWIFT-x) |
| Settlement Instruction Allegement - List            |  |
| Allegation Identification                           | Shows the unique identification of the allegation.   |
| Creation Date and Time                              | Shows the date and time when the allegation was created.<br><br>Displayed format is: YYYY-MM-DD hh:mm:ss:µsµsµsµsµs  |
| Status  | Shows the status of the allegation from the possible values:<br><br><input type="checkbox"/> Sent<br><input type="checkbox"/> Removed<br><input type="checkbox"/> Cancelled  |
| Alleging Depository BIC                             | Shows the BIC of the party that interacts with the depository.   |
| Alleging CSD Participant BIC                        | Shows the BIC of the CSD participant.  |

| Settlement Instruction Allegement – Search Criteria |   |
|---|---|
| ISIN  | Shows the ISIN of the security.   |
| Securities Account                                  | Shows the securities account number. For a RECE SI the securities account number is the securities account of the delivering party. For a DELI SI the securities account number is the securities account of the receiving party. |

**Buttons**

| Buttons |   |
|---------|---|
| Search  | <p>This function enables you to start a search according to the criteria entered. The results are displayed in a list on the same screen.</p> <p>If the search retrieves a single record, the <i>details</i> screen is displayed directly.</p> <p>Next screens:</p> <ul style="list-style-type: none"> <li><input type="checkbox"/> <i>Allegement instructions – search/list</i> screen</li> <li><input type="checkbox"/> <i>Allegement instruction – details</i> screen [ ▶ 93]</li> </ul> <p>Reference for error message [ ▶ 927]:</p> <ul style="list-style-type: none"> <li><input type="checkbox"/> QMPC015</li> </ul> |
| Reset   | <p>This function enables you to set default search criteria and blanks out all optional criteria.</p> <p>Next screen:</p> <ul style="list-style-type: none"> <li><input type="checkbox"/> <i>Allegement instructions – search/list</i> screen</li> </ul>  |
| Details | <p>This function enables you to display the details of the selected allegement instruction.</p> <p>Next screen:</p> <ul style="list-style-type: none"> <li><input type="checkbox"/> <i>Allegement instruction – details</i> screen [ ▶ 93]</li> </ul>   |

## 2.2.2.2 Allegement Instruction - Details Screen

**Context of Usage**

This screen displays detailed information on an allegement instruction. You can check the data and proceed further by clicking on the button below.

You can check the specific details of an allegement instruction and create a new settlement instruction based on the information of the allegement.

This screen is not available for CB users.

This function is only available in U2A mode.

**Screen Access**  Securities >> Settlement >> Settlement Instruction Allegements >> *Allegement instructions – search/list* screen >> Click on the *search and/or details* button

**Privileges** No privilege needed to use this screen.

**References** **User Instructions Part**

This screen is part of the following business scenarios:

- Respond to an allegement instruction [▶ 696]
- View allegement settlement instruction details [▶ 702]

**Business Functionality Document**

This screen corresponds to the following business function:

- Display allegement details (T2S.GUI.SESE.ALG.0030)

**Screenshot**

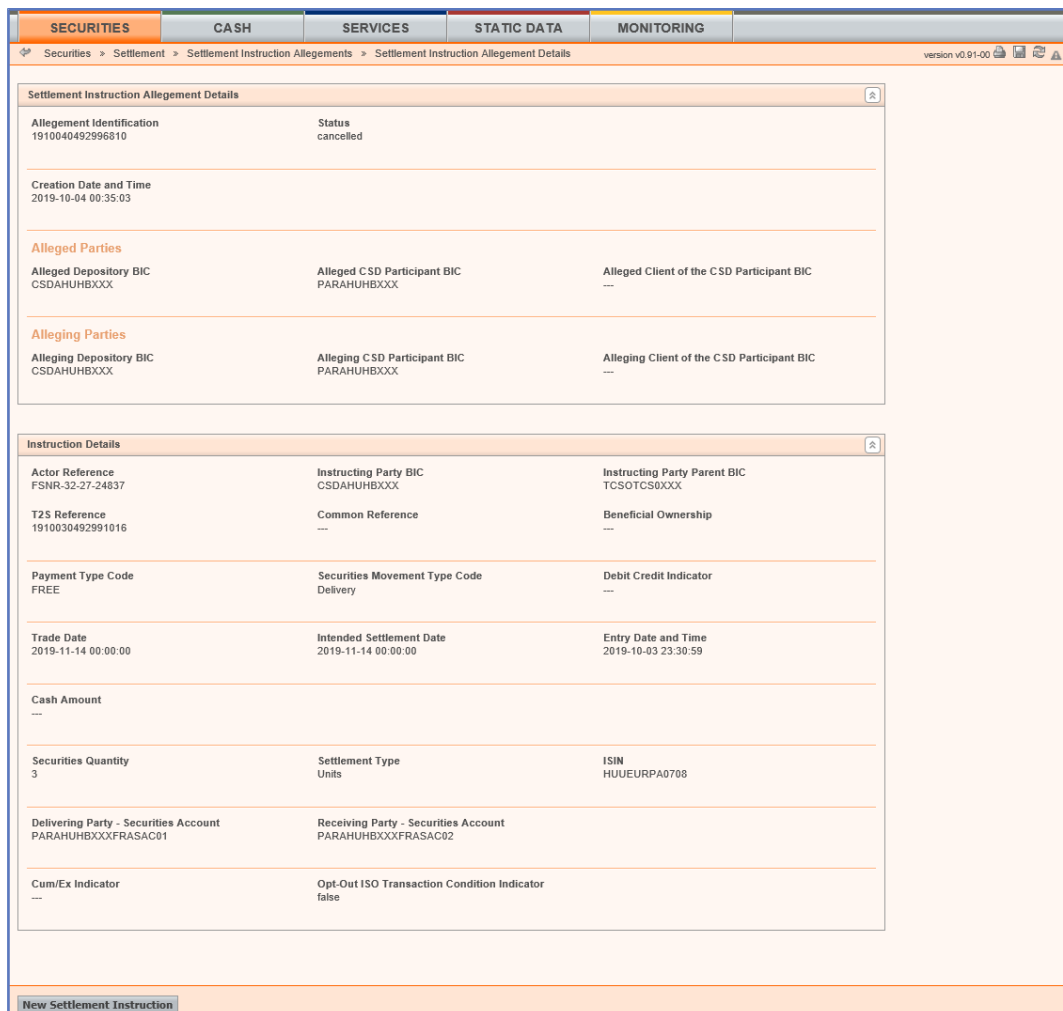

Illustration 43: Allegement instruction – details screen

**Field Description**

| Allegement Details        |  |
|---------------------------|--|
| Allegement Identification | Shows the unique identification of the allegement. |

| Allegation Details                         |   |
|--|---|
| Status                                     | Shows the status of the allegation from the possible values:<br><input type="checkbox"/> Sent<br><input type="checkbox"/> Removed<br><input type="checkbox"/> Cancelled |
| Creation Date and Time                     | Shows date and time when the allegation was created.<br>Displayed format is: YYYY-MM-DD hh:mm:ss:µsµsµsµsµs   |
| Alleged Parties                            |   |
| Alleged Depository BIC                     | Shows the BIC of the alleged party that interacts with the depository.  |
| Alleged CSD Participant BIC                | Shows the BIC of the alleged CSD participant.   |
| Alleged Client of the CSD Participant BIC  | Shows the BIC of the alleged client of the CSD participant.   |
| Alleging Parties                           |   |
| Alleging Depository BIC                    | Shows the BIC of the alleging party that interacts with the depository.   |
| Alleging CSD Participant BIC               | Shows the BIC of the alleging CSD participant.  |
| Alleging Client of the CSD Participant BIC | Shows the BIC of the client of the alleging CSD participant.  |
| Instruction Details                        |   |
| Actor Reference                            | Shows the identification of the settlement instruction assigned by the T2S actor.   |
| Instructing Party BIC                      | Shows the BIC of the instructing party of the settlement instruction.   |
| Instructing Party Parent BIC               | Shows the parent BIC of the instructing party of the settlement instruction.  |
| T2S Reference                              | Shows the identification of the settlement instruction assigned by T2S.   |
| Common Reference                           | Shows the reference provided by the T2S actor when the LCMM instruction is already matched or in order to facilitate the matching within T2S.                           |
| Beneficial Ownership                       | Shows if there is a change of beneficial ownership:<br><input type="checkbox"/> Empty (default value)   |

| Allegation Details                    |  |
|---------------------------------------|--|
|                                       | <input type="checkbox"/> Yes<br><input type="checkbox"/> No  |
| Payment Type Code                     | Shows if the transaction is to be settled with or without payment from the possible values:<br><input type="checkbox"/> APMT (for 'Against Payment Settlement')<br><input type="checkbox"/> FREE (for 'Separate Settlement') |
| Securities Movement Type Code         | Shows if the movement on a securities account results from a deliver or a receive instruction from the possible values:<br><input type="checkbox"/> DELI (for 'Delivery')<br><input type="checkbox"/> RECE (for 'Receive')   |
| Credit Debit Indicator                | Shows if the original settlement amount is to be credited or debited from the possible values:<br><input type="checkbox"/> CRDT (for 'Credit')<br><input type="checkbox"/> DBIT (for 'Debit')                                |
| Trade Date                            | Shows the date at which the contract was made.<br>Displayed format is: YYYY-MM-DD hh:mm:ss:µsµsµsµsµs  |
| Intended Settlement Date              | Shows the date at which the settlement instruction becomes eligible to be submitted to settlement.<br>Displayed format is: YYYY-MM-DD hh:mm:ss:µsµsµsµsµs  |
| Entry Date and Time                   | Shows the date and time when the settlement instruction has been created.<br>Displayed format is: YYYY-MM-DD hh:mm:ss:µsµsµsµsµs   |
| Cash Amount                           | Shows the settlement amount and the currency stated in the settlement instruction.   |
| Securities Quantity                   | Shows the quantity of the securities stated in the settlement instruction.   |
| Settlement Type                       | Shows the type of settlement foreseen for the security stated in the settlement instruction from the possible values:<br><input type="checkbox"/> Units<br><input type="checkbox"/> Face Amount                              |
| ISIN                                  | Shows the ISIN of the security.  |
| Delivering Party – Securities Account | Shows the number of the securities account of the delivering party.  |



| Allegation Details                          |  |
|---|--|
| Receiving Party – Securities Account        | Shows the number of the securities account of the receiving party.   |
| CUM/EX Indicator                            | Shows whether the contract was traded cum or ex coupon from the possible values: <ul style="list-style-type: none"> <li><input type="checkbox"/> Empty</li> <li><input type="checkbox"/> CUM</li> <li><input type="checkbox"/> EX</li> </ul> |
| Opt-Out ISO Transaction Condition Indicator | Shows the opt-out ISO transaction from the possible values: <ul style="list-style-type: none"> <li><input type="checkbox"/> No</li> <li><input type="checkbox"/> Yes</li> </ul>  |

**Buttons**

| Buttons                    |   |
|----------------------------|---|
| New Settlement Instruction | This function enables you to create a new settlement instruction with the information provided in the allegation instruction.<br><br>Next screen: <ul style="list-style-type: none"> <li><input type="checkbox"/> <i>Settlement instruction – new screen</i> [▶ 210]</li> </ul> |

### 2.2.2.3 Amendment Securities Instruction - Details Screen

**Context of Usage**

This screen displays detailed information on the selected amendment securities instruction. You can check the data and proceed further by clicking on the buttons below.

This screen is not relevant for CB users.

**Screen Access**

Securities >> Settlement >> Maintenance Securities Instructions >> *Maintenance securities instructions – search/list* screen >> Click on the *search* and/or *details* button

**Privileges**

To use this screen, you need the following privilege [▶ 867]:

Amendment instruction for intra-position movement or settlement instruction audit trail list query

**References**

**User Instructions Part**

This screen is part of the following business scenarios:

- View amendment instruction for a settlement instruction details [▶ 711]
- View amendment instruction for a settlement restriction on securities details [▶ 764]

### Business Functionality Document

This screen corresponds to the following business function:

- Display instruction details (T2S.GUI.SESE.INX.0030)

### Screenshot

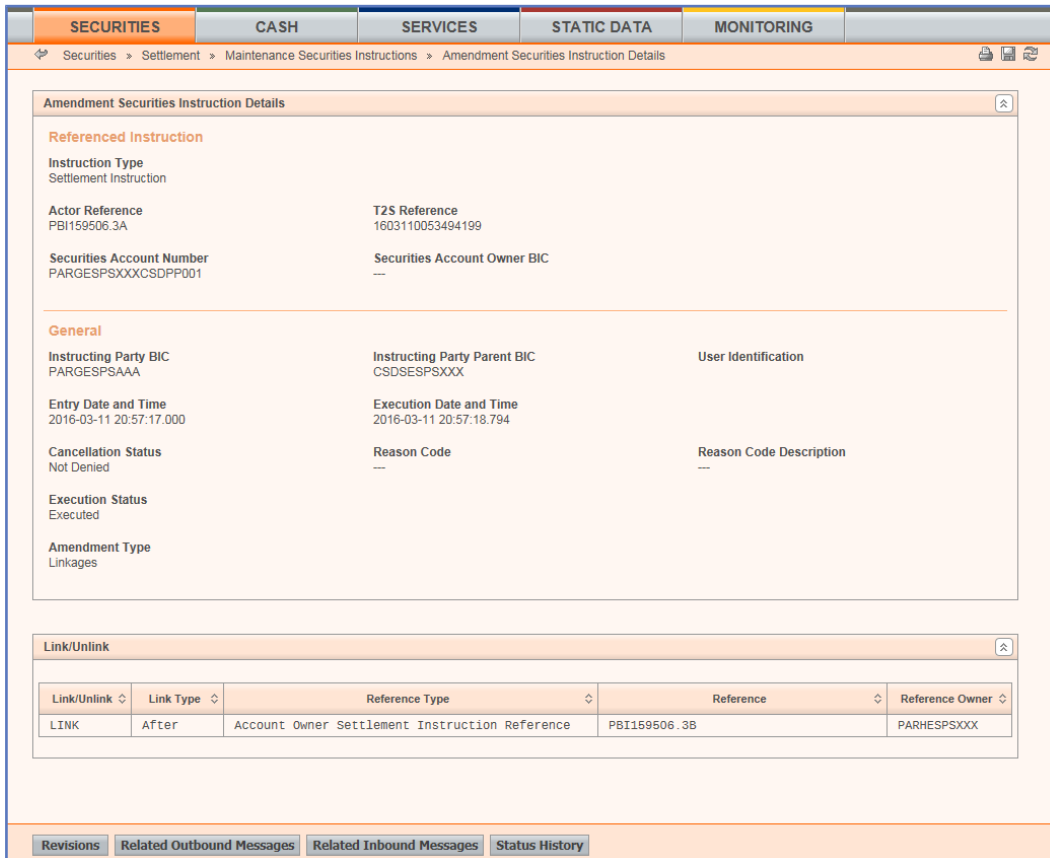

Illustration 44: Amendment securities instruction - details screen

### Field Description

| Amendment Securities Instruction Details |   |
|--|---|
| Referenced Instruction                   |   |
| Instruction Type                         | Shows the type of instruction referenced by the amendment instruction from the possible values: <ul style="list-style-type: none"> <li><input type="checkbox"/> Intra-position movement</li> <li><input type="checkbox"/> Settlement instruction</li> </ul> |
| Actor Reference                          | Shows the reference assigned by the T2S actor to the referenced instruction.  |
| T2S Reference                            | Shows the identification of the reference given the referenced instruction by T2S.  |
| Securities Account Number                | Shows the securities account number to or from which a securities entry is made.  |
| Securities Account Owner BIC             | Shows the BIC of the owner of the securities account.   |

| Amendment Securities Instruction Details |   |
|--|---|
| General                                  |   |
| Instructing Party BIC                    | Shows the BIC of the instructing party.   |
| Instructing Party Parent BIC             | Shows the parent BIC of the instructing party.  |
| User Identification                      | Shows user identification of the sending party.   |
| Entry Date and Time                      | Shows the date and time when the amendment instruction has entered in T2S.<br>Displayed format is: YYYY-MM-DD hh:mm:ss:µsµsµsµsµs   |
| Execution Date and Time                  | Shows the date and time when the amendment instruction has been executed.<br>Displayed format is: YYYY-MM-DD hh:mm:ss:µsµsµsµsµs  |
| Cancellation Status                      | Shows the cancellation status of the amendment instruction from the possible values:<br><input type="checkbox"/> DEND (for 'Denied')<br><input type="checkbox"/> NDEN (for 'Not denied')<br>If the 'Reason Code' field is informed, the cancellation status is set to 'Denied'.   |
| Reason Code                              | Shows the reason code that informs the reasoning why the amendment instruction has been denied.   |
| Reason Code Description                  | Shows the description of the reasoning why the amendment instruction has been denied.   |
| Execution Status                         | Shows the execution status of the amendment instruction from the possible values:<br><input type="checkbox"/> EXCD (for 'Executed')<br><input type="checkbox"/> NEXD (for 'Not executed')   |
| Amendment Type                           | Shows the amendment instruction type from the possible values:<br><input type="checkbox"/> Priority<br><input type="checkbox"/> Partial settlement<br><input type="checkbox"/> Linkages<br>If the value is set to 'Priority', the 'Priority' frame is displayed.<br>If the value is set to 'Partial Settlement', the 'Partial Settlement Indicator' frame is displayed. |

| Amendment Securities Instruction Details |  |
|--|--|
|  | If the value is set to 'Linkages', the 'Linkages' frame is displayed.  |
| Priority                                 |  |
| Priority                                 | Shows the value of the priority assigned by the amendment instruction from the possible values: <ul style="list-style-type: none"> <li><input type="checkbox"/> Normal</li> <li><input type="checkbox"/> High</li> <li><input type="checkbox"/> Reserved</li> </ul> This frame is only available if the amendment type is set to 'Priority'.   |
| Partial Settlement Indicator             |  |
| Partial Settlement Indicator             | Shows the value of the partial settlement indicator indicated in the amendment instruction from the possible values: <ul style="list-style-type: none"> <li><input type="checkbox"/> Partial not allowed</li> <li><input type="checkbox"/> Partial settlement cash threshold allowed</li> <li><input type="checkbox"/> Partial settlement quantity threshold allowed</li> <li><input type="checkbox"/> Partial allowed</li> </ul> This frame is only available if the amendment type is set to 'Partial Settlement Indicator'. |
| Link                                     |  |
| Link                                     | Shows the type of the link action indicated in the amendment instruction from the possible values: <ul style="list-style-type: none"> <li><input type="checkbox"/> Link</li> <li><input type="checkbox"/> Unlink</li> </ul> This frame is only available if the amendment type is set to 'Linkages'.   |
| Link Type                                | Shows the processing position indicated in the amendment instruction from the possible values: <ul style="list-style-type: none"> <li><input type="checkbox"/> After</li> <li><input type="checkbox"/> Before</li> <li><input type="checkbox"/> With</li> </ul> This frame is only available if the amendment type is set to 'Linkages'.   |

| Amendment Securities Instruction Details |   |
|--|---|
| Reference Type                           | <p>Shows the reference type of the instruction to be linked/unlinked to from the possible values:</p> <ul style="list-style-type: none"> <li><input type="checkbox"/> Account owner settlement instruction reference</li> <li><input type="checkbox"/> Account owner intra balance movement reference</li> <li><input type="checkbox"/> Account owner intra position movement reference</li> <li><input type="checkbox"/> Account servicer reference</li> <li><input type="checkbox"/> Third party reference</li> <li><input type="checkbox"/> T2S reference</li> </ul> <p>This frame is only available if the amendment type is set to 'Linkages'.</p> |
| Reference                                | <p>Shows the identification of the instruction to be linked/unlinked to.</p> <p>This frame is only available if the amendment type is set to 'Linkages'.</p>  |
| Reference Owner                          | <p>Shows the BIC of the instructing party of the instruction to be linked/unlinked to.</p> <p>This field is only filled in if the 'Reference Type' is set to any value different than 'T2S Reference'.</p> <p>This frame is only available if the amendment type is set to 'Linkages'.</p>  |

## Buttons

|                           |  |
|---------------------------|--|
| Revisions                 | <p>This function enables you to display the revisions of the selected amendment instruction.</p> <p>Next screen:</p> <ul style="list-style-type: none"> <li><input type="checkbox"/> <i>Revisions/audit trail – list</i> screen [▶ 661]</li> </ul>   |
| Related Outbound Messages | <p>This function enables you to display the outbound messages related to the amendment instruction.</p> <p>In case the selected amendment instruction is linked to more than one outbound message, the <i>outbound messages - search/list</i> screen is displayed.</p> <p>In case the query returns only one valid message, the <i>outbound message – details</i> screen is displayed directly.</p> <p>Next screens:</p> <ul style="list-style-type: none"> <li><input type="checkbox"/> <i>Outbound messages – search/list</i> screen [ 645]</li> </ul> |

|                          |  |
|--------------------------|--|
|                          | <ul style="list-style-type: none"> <li>□ <i>Outbound message – details</i> screen [ 653]</li> </ul>  |
| Related Inbound Messages | <p>This function enables you to display the inbound messages related to the amendment instruction.</p> <p>In case the selected amendment instruction is linked to more than one inbound message, the <i>inbound messages - search/list</i> screen is displayed.</p> <p>In case the query returns only one valid message, the <i>inbound message – details</i> screen is displayed directly.</p> <p>Next screens:</p> <ul style="list-style-type: none"> <li>□ <i>Inbound messages – search/list</i> screen [▶ 628]</li> <li>□ <i>Inbound message – details</i> screen [▶ 635]</li> </ul> |
| Status History           | <p>This function enables you to display the status history of the selected amendment instruction.</p> <p>Next screen:</p> <ul style="list-style-type: none"> <li>□ <i>Status history – details</i> screen [▶ 266]</li> </ul>   |

## 2.2.2.4 Amendment Securities Instruction - New Screen

### Context of Usage

This screen contains a number of fields regarding the amendment of settlement instructions or settlement restrictions on securities (intra-position movements) before their actual settlement or cancellation. You can enter new data. Afterwards you can proceed further by clicking on the buttons below.

This screen is not relevant for CB users.

You can use this screen either in 2-eyes or in 4-eyes mode.

### Screen Access

- Securities >> Settlement >> Settlement Instructions >> *Settlement instructions – search/list* screen >> Click on the *search* button >> *Settlement instructions – search/list* screen >> Click on the *details* button >> *Settlement instruction - details* screen >> Click on the *amendment instruction* button
- Securities >> Settlement >> Intra-Position Movements >> *Intra-position movements – search/list* screen >> Click on the *search* button >> *Intra-position movements – search/list* screen >> Click on the *details* button >> *Intra-position movement - details* screen >> Click on the *amendment instruction* button

### Privileges

To use this screen you need the following privileges [▶ 868]:

- Amend process indicator of a non-modifiable settlement instruction on behalf of the instructing party of the underlying instruction

- Send new instruction using a specific instructing party
- Link to an instruction/pool reference belonging to a specific party
- Amend process indicator of a settlement instruction/settlement restriction on securities either on a securities account or on behalf of the CSD in T2S or on behalf of an external CSD

**References**

**User Instructions Part**

This screen is part of the following business scenarios:

- Add a link for a settlement restriction on securities [▶ 757]
- Add a link for a settlement instruction [▶ 703]
- Amend partial settlement indicator for a settlement instruction [▶ 706]
- Amend priority for a settlement restriction on securities [▶ 760]
- Amend priority for a settlement instruction [▶ 707]
- Remove a link for a settlement restriction on securities [▶ 762]
- Remove a link for a settlement instruction [▶ 709]

**Business Functionality Document**

This screen corresponds to the following business function:

- Amend instruction (T2S.GUI.SESE.INX.0040)

**Screenshot**

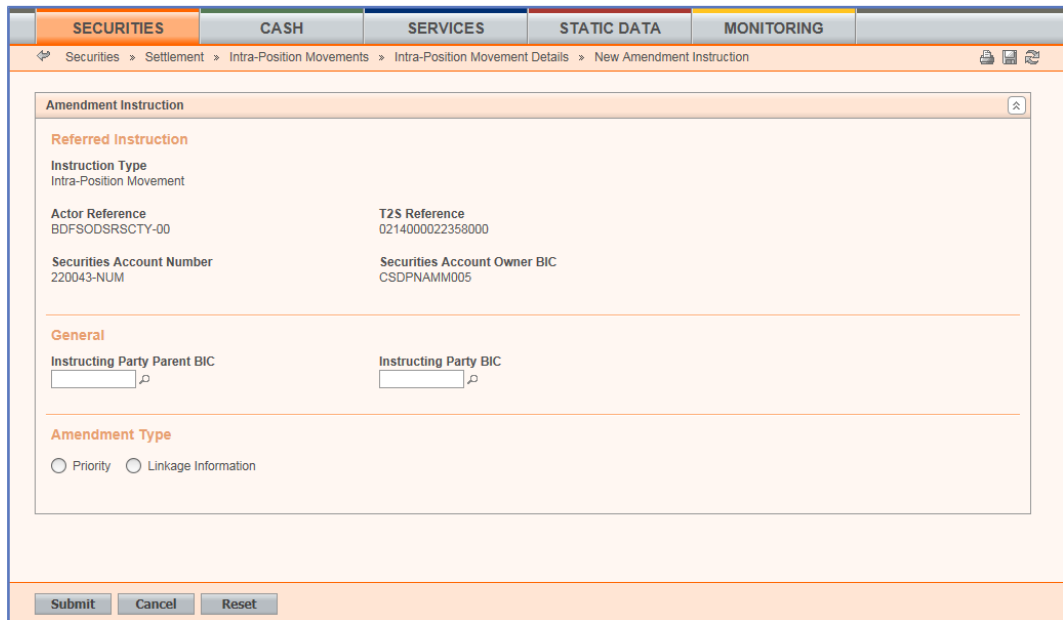

Illustration 45: Amendment securities instruction - new screen

**Field**

**Description**

| Amendment Instruction |  |
|-----------------------|--|
| Referred Instruction  |  |
| Instruction Type      | Shows the type of the referenced instruction from the possible values: |

| Amendment Instruction        |   |
|------------------------------|---|
|                              | <input type="checkbox"/> Settlement instruction<br><input type="checkbox"/> Intra position movement   |
| Actor Reference              | <p>Shows the identification of the referenced instruction assigned by the T2S actor.</p> <p>References for error messages: [▶ 937]</p> <input type="checkbox"/> MVCP004<br><input type="checkbox"/> MVCM957<br><input type="checkbox"/> MVCM958<br><input type="checkbox"/> MVCM959<br><input type="checkbox"/> MVCM960   |
| T2S Reference                | <p>Shows the identification of the referenced instruction assigned by T2S.</p> <p>References for error messages: [▶ 937]</p> <input type="checkbox"/> MVCP004<br><input type="checkbox"/> MVCM957<br><input type="checkbox"/> MVCM958<br><input type="checkbox"/> MVCM959<br><input type="checkbox"/> MVCM960<br><input type="checkbox"/> MVRI555<br><input type="checkbox"/> MVRI575<br><input type="checkbox"/> MVRI591 |
| Securities Account Number    | <p>Shows the number of the securities account.</p> <p>References for error messages: [▶ 937]</p> <input type="checkbox"/> MVCP027<br><input type="checkbox"/> MVCP044<br><input type="checkbox"/> MVCP032   |
| Securities Account Owner BIC | <p>Shows the BIC of the owner of the securities account of the referenced instruction.</p>  |
| Externally Matched           | <p>Shows whether the settlement instruction which was sent to T2S, is already matched or not.</p> <p>This field is only available, if the referenced instruction is a settlement instruction.</p>   |
| <b>General</b>               |   |



| Amendment Instruction              |  |
|------------------------------------|--|
| Instructing Party Parent BIC       | <p>Select the parent BIC of the instructing party from the drop-down menu or search via the <i>magnifier</i> icon.</p> <p>Required format is: max. 11 characters (SWIFT-x)</p> <p>References for error messages: [▶ 937]</p> <ul style="list-style-type: none"><li><input type="checkbox"/> MVDC026</li><li><input type="checkbox"/> MVCV107</li><li><input type="checkbox"/> MVCV232</li><li><input type="checkbox"/> MVSP209</li><li><input type="checkbox"/> MVCP122</li></ul> <p>In case the instructing party is not entered, the instructing party informed to the back end module will be the party you belong to. If the Instructing Party Parent BIC is filled in, the Instructing Party BIC has to be filled in too.</p> |
| Instructing Party BIC              | <p>Select the BIC of the instructing party from the drop-down menu or search via the <i>magnifier</i> icon.</p> <p>Required format is: max. 11 characters (SWIFT-x)</p> <p>References for error messages: [▶ 937]</p> <ul style="list-style-type: none"><li><input type="checkbox"/> MVDC026</li><li><input type="checkbox"/> MVCV107</li><li><input type="checkbox"/> MVCV232</li><li><input type="checkbox"/> MVSP209</li><li><input type="checkbox"/> MVCP122</li></ul> <p>In case the instructing party is not entered, the instructing party informed to the back end module will be the party you belong to. If the Instructing Party BIC is filled in, the Instructing Party Parent BIC has to be filled in too.</p>        |
| Amendment Counterparty Instruction | <p>Select this checkbox to amend both legs of the referenced settlement instruction.</p> <p>References for error messages: [▶ 937]</p> <ul style="list-style-type: none"><li><input type="checkbox"/> MVCP108</li><li><input type="checkbox"/> MVCP109</li></ul> <p>This field is only available if the referenced instruction is a settlement instruction.</p>  |

| Amendment Instruction |   |
|-----------------------|---|
|                       | If the referenced settlement instruction is not an already matched instruction or the actor reference is empty the field is greyed out.   |
| Amendment Type        |   |
| Amendment Type        | <p>Select the type of amendment of the instruction from the possible values:</p> <ul style="list-style-type: none"> <li><input type="checkbox"/> Priority</li> <li><input type="checkbox"/> Linkage information</li> <li><input type="checkbox"/> Partial settlement indicator (only available in the screen if the referenced instruction is a settlement instruction)</li> </ul> <p>References for error messages: [▶ 937]</p> <ul style="list-style-type: none"> <li><input type="checkbox"/> MMIA003</li> <li><input type="checkbox"/> MMIA004</li> <li><input type="checkbox"/> MVCM952</li> </ul> <p>If the amendment type is 'Priority', the fields related to the partial settlement block and the linkages block will not be available.</p> <p>If the amendment type is 'Linkage Information', the fields related to the partial settlement block and the priority block will not be available.</p> <p>If the amendment type is 'Partial Settlement Indicator', the fields related to the priority block and the linkages block will not be available.</p> |
| Priority              |   |
| Priority              | <p>Select the level of the priority from the possible values:</p> <ul style="list-style-type: none"> <li><input type="checkbox"/> Normal (default value)</li> <li><input type="checkbox"/> High</li> <li><input type="checkbox"/> Reserved</li> </ul> <p>Reference for error message: [▶ 937]</p> <ul style="list-style-type: none"> <li><input type="checkbox"/> MVSP209</li> </ul> <p>This frame is only available if the amendment type is set to 'Priority'.</p>  |
| Linkage Information   |   |
| Link/Unlink           | Select the type of the amendment on links to be performed from the possible values:   |

| Amendment Instruction |   |
|-----------------------|---|
|                       | <input type="checkbox"/> Link<br><input type="checkbox"/> Unlink<br>References for error messages: [▶ 937]<br><input type="checkbox"/> MVCM957<br><input type="checkbox"/> MVCM958<br><input type="checkbox"/> MVCM959<br><input type="checkbox"/> MVCM960<br><input type="checkbox"/> MVLI810<br><input type="checkbox"/> MVLI811<br><input type="checkbox"/> MVLI825<br><input type="checkbox"/> MVLI826<br><input type="checkbox"/> MVLI827<br><input type="checkbox"/> MVLI828<br><input type="checkbox"/> MVLI829<br><input type="checkbox"/> MVLI830<br><input type="checkbox"/> MVLI837<br><input type="checkbox"/> MVLI838<br><input type="checkbox"/> MVLI839<br><input type="checkbox"/> MVLI853<br><input type="checkbox"/> MVLI856<br><input type="checkbox"/> MVLI859<br><input type="checkbox"/> MVLI862<br><input type="checkbox"/> MVLI871<br>This frame is only available if the amendment type is set to 'Linkage Information'. |
| Link                  |   |
| Link Type*            | Select the processing position of the link from the possible values:<br><input type="checkbox"/> After<br><input type="checkbox"/> Before<br><input type="checkbox"/> With<br>References for error messages: [▶ 937]  |

| Amendment Instruction |   |
|-----------------------|---|
|                       | <ul style="list-style-type: none"> <li><input type="checkbox"/> MVCP040</li> <li><input type="checkbox"/> MVCP041</li> <li><input type="checkbox"/> MVLI809</li> <li><input type="checkbox"/> MVLI810</li> <li><input type="checkbox"/> MVLI811</li> <li><input type="checkbox"/> MVLI825</li> <li><input type="checkbox"/> MVLI826</li> <li><input type="checkbox"/> MVLI827</li> <li><input type="checkbox"/> MVLI828</li> <li><input type="checkbox"/> MVLI829</li> <li><input type="checkbox"/> MVLI830</li> <li><input type="checkbox"/> MVLI837</li> <li><input type="checkbox"/> MVLI838</li> <li><input type="checkbox"/> MVLI839</li> <li><input type="checkbox"/> MVLI853</li> <li><input type="checkbox"/> MVLI856</li> <li><input type="checkbox"/> MVLI859</li> <li><input type="checkbox"/> MVLI862</li> <li><input type="checkbox"/> MVLI874</li> </ul> <p>This frame is only available if the amendment type is set to 'Linkage Information'.</p> <p>This field is also available as a show field for existing records.</p> |
| Reference Type*       | <p>Select the reference type of the instruction to be linked/unlinked to from the possible values:</p> <ul style="list-style-type: none"> <li><input type="checkbox"/> Account Owner Settlement Instruction Reference</li> <li><input type="checkbox"/> Account Owner Intra Balance Movement Reference</li> <li><input type="checkbox"/> Account Owner Intra Position Movement Reference</li> <li><input type="checkbox"/> Account Servicer Reference</li> <li><input type="checkbox"/> Third Party reference</li> <li><input type="checkbox"/> T2S reference</li> </ul> <p>Reference for error message: [ ▶ 937]</p> <ul style="list-style-type: none"> <li><input type="checkbox"/> MVCP099</li> </ul>  |

| Amendment Instruction        |   |
|------------------------------|---|
|                              | <p>This frame is only available if the amendment type is set to 'Linkage Information'.</p> <p>This field is also available as a show field for existing records.</p>  |
| Reference*                   | <p>Enter the identification of the instruction to be linked/unlinked to. Required format is: max. 16 characters (SWIFT-x-red)</p> <p>References for error messages: [▶ 937]</p> <ul style="list-style-type: none"> <li><input type="checkbox"/> MVCP099</li> <li><input type="checkbox"/> MVLI871</li> <li><input type="checkbox"/> MVLI874</li> </ul> <p>This frame is only available if the amendment type is set to 'Linkage Information'.</p> <p>This field is also available as a show field for existing records.</p> |
| Reference Owner              | <p>Enter the BIC of the instructing party of the instruction to be linked/unlinked to.</p> <p>Required format is: max. 11 characters (SWIFT-x)</p> <p>If the 'Reference Type' is set to any value different than 'T2S reference' this field becomes mandatory.</p> <p>This frame is only available if the amendment type is set to 'Linkage Information'.</p> <p>This field is also available as a show field for existing records.</p>   |
| Options                      | <p>Information on functions (icons) can be found in Common Buttons and Icons.</p>   |
| Partial Settlement Indicator |   |
| Partial Settlement Indicator | <p>Select the value of the partial settlement indicator corresponding to the T2S settlement instruction reference from the possible values:</p> <ul style="list-style-type: none"> <li><input type="checkbox"/> Partial not allowed (default value)</li> <li><input type="checkbox"/> Partial settlement cash threshold allowed</li> <li><input type="checkbox"/> Partial settlement quantity threshold allowed</li> <li><input type="checkbox"/> Partial allowed</li> </ul>  |

### Amendment Instruction

If the amendment request aims at modifying the partial settlement indicator associated to settlement instructions, this field is mandatory.

This frame is only available if the amendment type is set to 'Partial Settlement Indicator'.

### Buttons

#### Submit

This function enables you to create a new amendment securities instruction. Upon clicking on the *submit* button you will be asked to enter your PIN for digital signature purposes (NRO). With the entry of the PIN, T2S attaches a digital signature to the instruction entered by the T2S actor.

Next screens:

- Settlement instructions – search/list* screen [▶ 176] (for a settlement instruction)
- Intra-position movements – search/list* screen [▶ 136] (for a settlement restriction on securities)

References for error messages: [▶ 937]

- MMIA001
- MMIA002
- MMIA003
- MMIA004
- MMIA005
- MMIA006
- MMIA009
- MVCM952
- MVCM955
- MVCM956
- MVCM957
- MVCM958
- MVCM959
- MVCM960
- MVCP004
- MVCP027
- MVCP028

- MVCP032
- MVCP039
- MVCP040
- MVCP041
- MVCP044
- MVCP095
- MVCP099
- MVCP108
- MVCP109
- MVCP122
- MCVV107
- MCVV232
- MVDC026
- MVLI809
- MVLI810
- MVLI811
- MVLI825
- MVLI826
- MVLI827
- MVLI828
- MVLI829
- MVLI830
- MVLI837
- MVLI838
- MVLI839
- MVLI853
- MVLI856
- MVLI859
- MVLI862
- MVLI871
- MVLI874
- MVRI555

|        |  |
|--------|--|
|        | <input type="checkbox"/> MVRI575<br><input type="checkbox"/> MVRI591<br><input type="checkbox"/> MVSP209   |
| Reset  | <p>This function enables you to set all fields to default value and blanks out all optional fields.</p> <p>Next screen:</p> <input type="checkbox"/> <i>Amendment securities instruction - new</i> screen  |
| Cancel | <p>This function enables you to cancel the process and return to the previous screen.</p> <p>Next screens:</p> <input type="checkbox"/> <i>Settlement instruction - details</i> screen [▶ 191] (for a settlement instruction)<br><input type="checkbox"/> <i>Intra-position movement - details</i> screen [▶ 143] (for a settlement restriction on securities) |

## 2.2.2.5 Cancellation Securities Instruction - Details Screen

### Context of Usage

This screen displays detailed information on the selected cancellation securities instruction. You can check the data and proceed further by clicking on the buttons below.

This screen is not relevant for CB users.

### Screen Access

Securities >> Settlement >> Maintenance Securities Instructions >> *Maintenance securities instructions – search/list* screen >> Click on the *search* button >> *Maintenance securities instructions – search/list* screen >> Click on the *details* button

### Privileges

To use this screen, you need the following privilege [▶ 877]:

Cancellation instruction for intra-position movement or settlement instruction audit trail list query

### References

#### User Instructions Part

This screen is part of the following business scenarios:

View cancellation instruction for a settlement instruction details [▶ 729]  
 View cancellation instruction for a settlement restriction on securities details [▶ 775]

#### Business Functionality Document

This screen corresponds to the following business function:



Display instruction details (T2S.GUI.SESE.INX.0030)

**Screenshot**

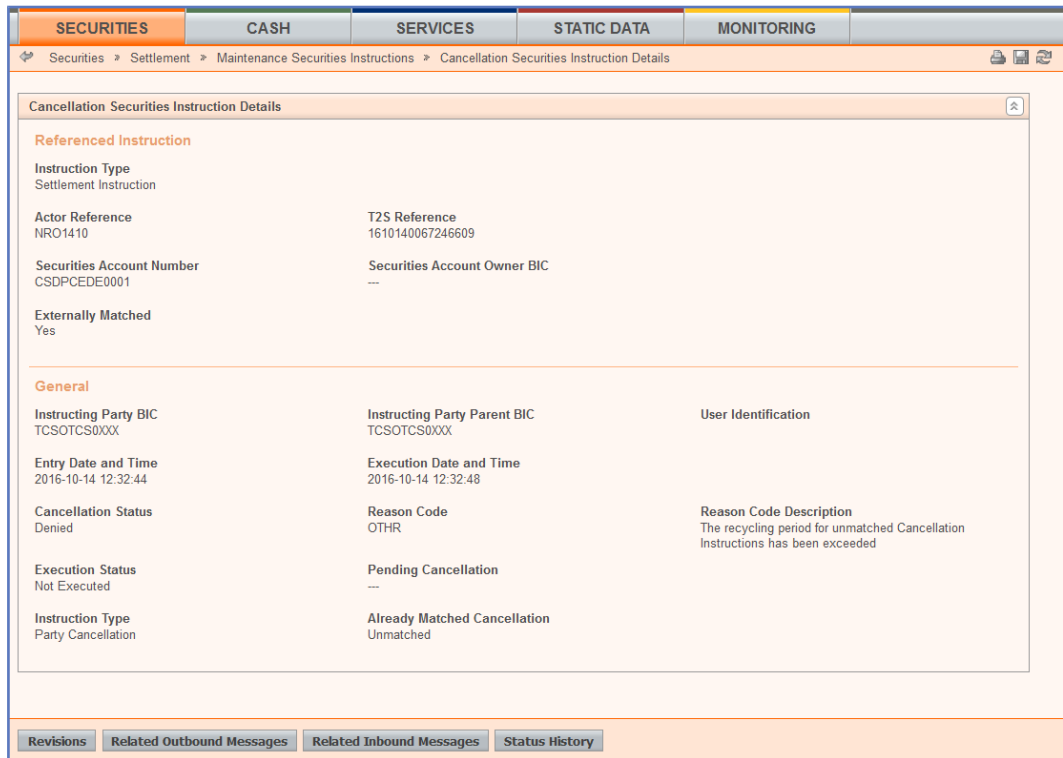

Illustration 46: Cancellation securities instruction - details screen

**Field**

**Description**

| Cancellation Securities Instruction Details |   |
|---|---|
| Referenced Instruction                      |   |
| Instruction Type                            | Shows the type of instruction referenced by the cancellation instruction from the possible values:<br><input type="checkbox"/> Intra-position movement<br><input type="checkbox"/> Settlement instruction |
| Actor Reference                             | Shows the reference assigned by the T2S actor to the referenced instruction   |
| T2S Reference                               | Shows the identification of the reference given to the referenced instruction by T2S.   |
| Securities Account Number                   | Shows the securities account number to or from which a securities entry is made.  |
| Securities Account Owner BIC                | Shows the owner of the securities account.  |
| Externally Matched                          | Shows if the settlement instruction is externally matched or not from the possible values:<br><input type="checkbox"/> Yes<br><input type="checkbox"/> No   |

| Cancellation Securities Instruction Details |  |
|---|--|
|   | This field is only available, if the instruction type is set to 'Settlement Instruction'.  |
| General                                     |  |
| Instructing Party BIC                       | Shows the BIC of the instructing party.  |
| Instructing Party Parent BIC                | Shows the parent BIC of the instructing party.   |
| User Identification                         | Shows user identification of the sending party.  |
| Entry Date and Time                         | Shows the date and time when the cancellation instruction has entered in T2S.<br>Displayed format is: YYYY-MM-DD hh:mm:ss  |
| Execution Date and Time                     | Shows the date and time when the cancellation instruction has been executed.<br>Displayed format is: YYYY-MM-DD hh:mm:ss   |
| Cancellation Status                         | Shows the cancellation status of the cancellation instruction from the possible values:<br><input type="checkbox"/> Denied<br><input type="checkbox"/> Not denied  |
| Reason Code                                 | Shows the reason code that informs the reasoning why the cancellation instruction has been denied or has not yet been executed.  |
| Reason Code Description                     | Shows the description of the reasoning why the cancellation instruction has been denied or has not yet been executed.  |
| Execution Status                            | Shows the execution status of the cancellation instruction from the possible values:<br><input type="checkbox"/> Executed<br><input type="checkbox"/> Not executed   |
| Pending Cancellation                        | Shows if the cancellation instruction is pending to be executed, awaiting for cancellation from the counterparty or CoSD cancellation from another administering party from the possible values:<br><input type="checkbox"/> Empty (default value)<br><input type="checkbox"/> Yes |

| Cancellation Securities Instruction Details |  |
|---|--|
|   | This field is only available, if the instruction type is set to 'Settlement Instruction' and if the settlement instruction has been matched  |
| Instruction Type                            | Shows the cancellation instruction type from the possible values: <ul style="list-style-type: none"> <li><input type="checkbox"/> Party cancellation</li> <li><input type="checkbox"/> CSD cancellation</li> <li><input type="checkbox"/> CoSD cancellation (only possible if the instruction type is a settlement instruction)</li> </ul> |
| Already Matched Cancellation                | Shows if the cancellation instruction is externally matched or not from the possible values: <ul style="list-style-type: none"> <li><input type="checkbox"/> Yes</li> <li><input type="checkbox"/> No</li> </ul>   |

## Buttons

|                           |   |
|---------------------------|---|
| Revisions                 | This function enables you to display the revisions of the selected cancellation instruction.<br>Next screen: <ul style="list-style-type: none"> <li><input type="checkbox"/> <i>Revisions/audit trail – list</i> screen [▶ 661]</li> </ul>  |
| Related Outbound Messages | This function enables you to display the outbound messages related to the cancellation instruction.<br>In case the selected cancellation instruction is linked to more than one outbound message, the <i>outbound messages - search/list</i> screen is displayed.<br>If the search retrieves a single message, the <i>outbound message – details</i> screen is displayed directly.<br>Next screens: <ul style="list-style-type: none"> <li><input type="checkbox"/> <i>Outbound messages – search/list</i> screen [▶ 645]</li> <li><input type="checkbox"/> <i>Outbound message – details</i> screen [▶ 653]</li> </ul> |
| Related Inbound Messages  | This function enables you to display the inbound message related to the cancellation instruction.<br>In case the selected cancellation instruction is linked to more than one inbound message, the <i>inbound messages - search/list</i> screen is displayed.<br>If the search retrieves a single message, the <i>inbound message – details</i> screen is displayed directly.   |

|                |  |
|----------------|--|
|                | <p>Next screens:</p> <ul style="list-style-type: none"> <li><input type="checkbox"/> <i>Inbound messages – search/list</i> screen [▶ 628]</li> <li><input type="checkbox"/> <i>Inbound message – details</i> screen [▶ 635]</li> </ul>                 |
| Status History | <p>This function enables you to display the status history of the selected cancellation instruction.</p> <p>Next screen:</p> <ul style="list-style-type: none"> <li><input type="checkbox"/> <i>Status history – details</i> screen [▶ 266]</li> </ul> |

## 2.2.2.6 Cancellation Securities Instruction - New Screen

### Context of Usage

This screen contains a number of fields regarding cancellation securities instructions. You can enter new data. Afterwards you can proceed further by clicking on the buttons below.

You can use this screen either in 2-eyes or in 4-eyes mode.

This screen is not relevant for CB users.

### Screen Access

- Securities >> Settlement >> Settlement Instructions >> *Settlement instructions – search/list* screen >> Click on the *search* button >> *Settlement instructions – search/list* screen >> Click on the *details* button >> *Settlement instruction - details* screen >> Click on the *cancellation instruction* button
- Securities >> Settlement >> Intra-Position Movements >> *Intra-position movements – search/list* screen >> Click on the *search* button >> *Intra-position movements – search/list* screen >> Click on the *details* button >> *Intra-position movement - details* screen >> Click on the *cancellation instruction* button

### Privileges

To use this screen you need the following privileges [▶ 877]:

- Send new instruction using a specific instructing party
- Cancel settlement instruction/settlement restriction on securities either on a securities account or on behalf of the CSD in T2S, on behalf of external CSD or on behalf of an administering party
- Cancel non-modifiable instructions on behalf of the instructing party of the underlying settlement instruction

### References

#### User Instructions Part

This screen is part of the following business scenarios:

- Cancel a settlement restriction on securities [▶ 773]
- Cancel a settlement instruction [▶ 727]

### Business Functionality Document

This screen corresponds to the following business function:

- Cancel instruction (T2S.GUI.SESE.INX.0050)

### Screenshot

Illustration 47: Cancellation securities instruction - new screen

### Field

### Description

| Cancellation Instruction  |   |
|---------------------------|---|
| Referenced Instruction    |   |
| Instruction Type          | Shows the type of the referenced instruction from the possible values: <ul style="list-style-type: none"> <li><input type="checkbox"/> Settlement instruction</li> <li><input type="checkbox"/> Intra-position movement</li> </ul>  |
| Actor Reference           | Shows the identification of the referenced instruction assigned by the T2S actor.<br>Reference for error message [ ▶ 958]: <ul style="list-style-type: none"> <li><input type="checkbox"/> MVCP003</li> <li><input type="checkbox"/> MVRI592</li> </ul>                       |
| T2S Reference             | Shows the identification of the referenced instruction assigned by T2S.<br>References for error messages [ ▶ 958]: <ul style="list-style-type: none"> <li><input type="checkbox"/> MVCP003</li> <li><input type="checkbox"/> MVRI592</li> </ul>                               |
| Securities Account Number | Shows the securities account of the referenced instruction.<br>References for error messages [ ▶ 958]: <ul style="list-style-type: none"> <li><input type="checkbox"/> MVCP044</li> <li><input type="checkbox"/> MVCP029</li> <li><input type="checkbox"/> MVCP033</li> </ul> |

| Cancellation Instruction     |  |
|------------------------------|--|
| Securities Account Owner BIC | Shows the BIC of the owner of the securities account of the referenced instruction.  |
| Externally Matched           | Shows if the settlement instruction is externally matched from the possible values: <ul style="list-style-type: none"> <li><input type="checkbox"/> Yes</li> <li><input type="checkbox"/> No</li> </ul> <p>If the referenced instruction is a settlement instruction, this field is only available.</p>  |
| General                      |  |
| Instructing Party Parent BIC | Select the parent BIC of the instructing party from the drop-down menu or search via the <i>magnifier</i> icon.<br>Required format is: max. 11 characters (SWIFT-x)<br>References for error messages [ ▶ 958]: <ul style="list-style-type: none"> <li><input type="checkbox"/> MVRI594</li> <li><input type="checkbox"/> MVDC027</li> <li><input type="checkbox"/> MVCV108</li> <li><input type="checkbox"/> MVCV231</li> <li><input type="checkbox"/> MMCI106</li> <li><input type="checkbox"/> MMCI105</li> <li><input type="checkbox"/> MMCI107</li> <li><input type="checkbox"/> MMCI108</li> <li><input type="checkbox"/> MMCI109</li> <li><input type="checkbox"/> MVRI592</li> <li><input type="checkbox"/> MVCP123</li> </ul> <p>In case the instructing party is not entered, the instructing party informed to the back end module will be the party you belong to. If the 'Instructing Party Parent BIC' is filled in, the 'Instructing Party BIC' has to be filled in too.</p> |
| Instructing Party BIC        | Select the BIC of the instructing party from the drop-down menu or search via the <i>magnifier</i> icon.<br>Required format is: max. 11 characters (SWIFT-x)<br>References for error messages [ ▶ 958]: <ul style="list-style-type: none"> <li><input type="checkbox"/> MVRI594</li> <li><input type="checkbox"/> MVDC027</li> </ul>   |

| Cancellation Instruction     |   |
|------------------------------|---|
|                              | <ul style="list-style-type: none"> <li><input type="checkbox"/> MVCV108</li> <li><input type="checkbox"/> MVCV231</li> <li><input type="checkbox"/> MMCI106</li> <li><input type="checkbox"/> MVCP104</li> <li><input type="checkbox"/> MVCP105</li> <li><input type="checkbox"/> MVCP123</li> <li><input type="checkbox"/> MMCI105</li> <li><input type="checkbox"/> MMCI107</li> <li><input type="checkbox"/> MMCI108</li> <li><input type="checkbox"/> MMCI109</li> <li><input type="checkbox"/> MVRI592</li> </ul> <p>In case the instructing party is not entered, the instructing party informed to the back end module will be the party you belong to. If the 'Instructing Party BIC' is filled in, the 'Instructing Party Parent BIC' has to be filled in too.</p> |
| Already Matched Cancellation | <p>Select the already matched cancellation value to cancel both legs of the settlement instruction.</p> <p>This field is only available if the referenced instruction is a settlement instruction.</p> <p>If the referenced settlement instruction is not an already matched instruction or the actor reference is empty the field is greyed out.</p> <p>References for error messages [ ▶ 958]:</p> <ul style="list-style-type: none"> <li><input type="checkbox"/> MVCP104</li> <li><input type="checkbox"/> MVCP105</li> </ul>   |
| Reason for cancellation      | <p>Select the applicable reason for the cancellation of the settlement instruction from the possible values:</p> <ul style="list-style-type: none"> <li><input type="checkbox"/> Empty (default value)</li> <li><input type="checkbox"/> BYIY</li> <li><input type="checkbox"/> CANT (Cancelled due to transformation)</li> <li><input type="checkbox"/> CANI</li> <li><input type="checkbox"/> CTHP</li> <li><input type="checkbox"/> CSUB</li> <li><input type="checkbox"/> CXLR</li> </ul>   |

| Cancellation Instruction          |   |
|-----------------------------------|---|
|                                   | <ul style="list-style-type: none"> <li><input type="checkbox"/> CANZ</li> <li><input type="checkbox"/> CORP</li> <li><input type="checkbox"/> SCEX</li> <li><input type="checkbox"/> OTHR</li> </ul> <p>This field is only available if the referenced instruction is a settlement instruction or intra-position movement</p> |
| Corporate Action Event Identifier | <p>Enter the identification of the corporate action event.</p> <p>Required format is: max. 16 characters (SWIFT-x-red)</p>  |

### Buttons

| Submit | <p>This function enables you to create a new cancellation securities instruction. Upon clicking on the <i>submit</i> button you will be asked to enter your PIN for digital signature purposes (NRO). With the entry of the PIN, T2S attaches a digital signature to the instruction entered by the T2S actor.</p> <p>Next screens:</p> <ul style="list-style-type: none"> <li><input type="checkbox"/> <i>Intra-position movements– search/list</i> screen [ ▶ 136] (for a settlement instruction)</li> <li><input type="checkbox"/> <i>Settlement instructions– search/list</i> screen [ ▶ 176] (for a settlement restriction on securities)</li> </ul> <p>References for error messages [ ▶ 958]:</p> <ul style="list-style-type: none"> <li><input type="checkbox"/> MMCR201</li> <li><input type="checkbox"/> MMCR202</li> <li><input type="checkbox"/> MMCI101</li> <li><input type="checkbox"/> MMCI102</li> <li><input type="checkbox"/> MMCI105</li> <li><input type="checkbox"/> MMCI106</li> <li><input type="checkbox"/> MMCI107</li> <li><input type="checkbox"/> MMCI108</li> <li><input type="checkbox"/> MMCI109</li> <li><input type="checkbox"/> MVCP003</li> <li><input type="checkbox"/> MVCP029</li> <li><input type="checkbox"/> MVCP030</li> <li><input type="checkbox"/> MVCP031</li> </ul> |
|--------|---|



|        |  |
|--------|--|
|        | <input type="checkbox"/> MVCP033<br><input type="checkbox"/> MVCP044<br><input type="checkbox"/> MVCP048<br><input type="checkbox"/> MVCP096<br><input type="checkbox"/> MVCP104<br><input type="checkbox"/> MVCP105<br><input type="checkbox"/> MVCP123<br><input type="checkbox"/> MCVV108<br><input type="checkbox"/> MCVV231<br><input type="checkbox"/> MVDC027<br><input type="checkbox"/> MVRI576<br><input type="checkbox"/> MVRI592<br><input type="checkbox"/> MVRI594 |
| Reset  | <p>This function enables you to set all fields to default value and blanks out all optional fields.</p> <p>Next screen:</p> <input type="checkbox"/> <i>Cancellation securities instruction - new screen</i>   |
| Cancel | <p>This function enables you to cancel the process and return to the previous screen.</p> <p>Next screens:</p> <input type="checkbox"/> <i>Settlement instruction - details screen [▶ 191]</i> (for a settlement instruction)<br><input type="checkbox"/> <i>Intra-position movement - details screen [▶ 143]</i> (for a settlement restriction on securities)   |

### 2.2.2.7 Data Changes - Search/List Screen

See *Data Changes – Search/List Screen* [▶ 607].

### 2.2.2.8 Data Change - Details Screen

See *Data Changes – Details Screen* [▶ 611].

### 2.2.2.9 Hold/Release Instruction - Details Screen

#### Context of Usage

This screen displays detailed information on the selected hold/release instruction. You can check the data and proceed further by clicking on the buttons below.

This screen is not relevant for CB users.

**Screen Access**

- Securities >> Settlement >> Maintenance Securities Instructions >> *Maintenance securities instructions – search/list* screen >> Click on the *search* and/or *details* button

**Privileges**

To use this screen, you need the following privilege [**▶ 881**]:

- Hold/release audit trail list query

**References**

**User Instructions Part**

This screen is part of the following business scenario:

- View hold/release instruction details [**▶ 725**]

**Business Functionality Document**

This screen corresponds to the following business function:

- Display instruction details (T2S.GUI.SESE.INX.0030)

**Screenshot**

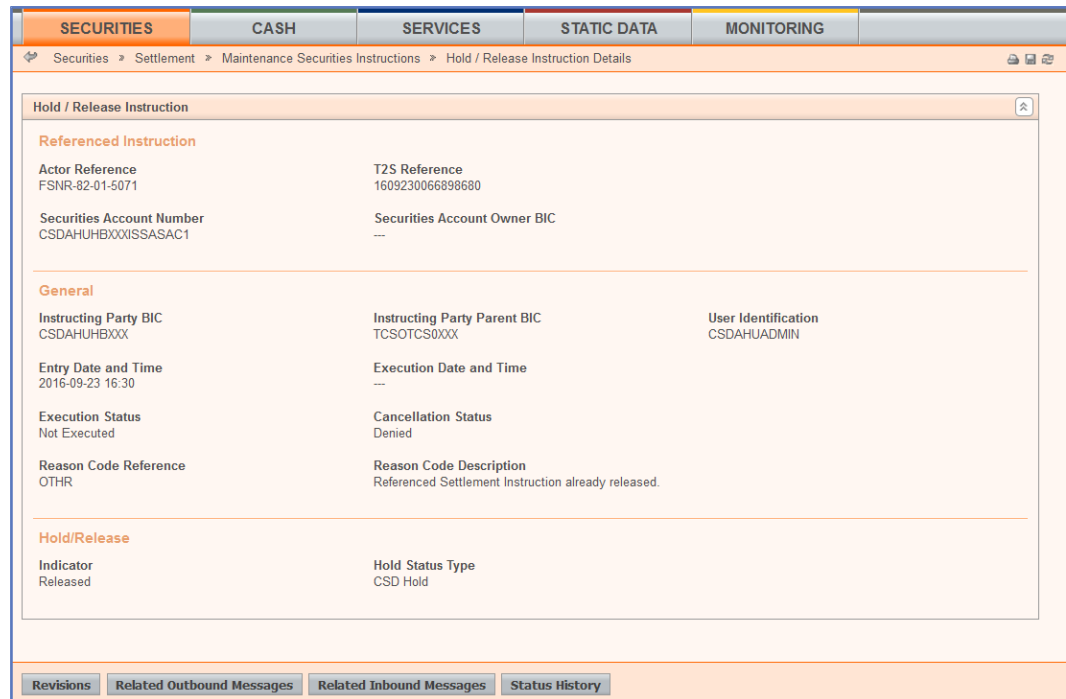

Illustration 48: Hold/release instruction – details screen

**Field Description**

| Hold/Release Instruction  |  |
|---------------------------|--|
| Referenced Instruction    |  |
| Actor Reference           | Shows the reference assigned by the T2S actor to the referenced instruction.             |
| T2S Reference             | Shows the identification of the reference assigned to the referenced instruction by T2S. |
| Securities Account Number | Shows the securities account number to or from which a securities entry is made.         |

| Hold/Release Instruction     |  |
|------------------------------|--|
| Securities Account Owner BIC | Shows the owner of the securities account.   |
| <b>General</b>               |  |
| Instructing Party BIC        | Shows the BIC of the instructing party.  |
| Instructing Party Parent BIC | Shows the parent BIC of the instructing party.   |
| User Identification          | Shows user identification of the sending party.  |
| Entry Date and Time          | Shows the date and time when the hold/release instruction has entered in T2S.<br>Displayed format is: YYYY-MM-DD hh:mm:ss:µsµsµsµsµs   |
| Execution Date and Time      | Shows the date and time when the hold/release instruction has been executed.<br>Displayed format is: YYYY-MM-DD hh:mm:ss:µsµsµsµsµs  |
| Execution Status             | Shows the execution status of the hold/release instruction from the possible values:<br><input type="checkbox"/> Executed<br><input type="checkbox"/> Not executed   |
| Cancellation Status          | Shows the cancellation status of the hold/release instruction from the possible values:<br><input type="checkbox"/> Denied<br><input type="checkbox"/> Not denied<br>If the 'Reason Code Reference' field is filled in, the cancellation status is always set to 'Denied'. |
| Reason Code Reference        | Shows the reason code that informs the reasoning why the hold/release instruction has been denied.   |
| Reason Code Description      | Shows the description that informs the reason why the hold/release instruction has been denied.  |
| <b>Hold/Release</b>          |  |
| Indicator                    | Shows the hold/release instruction type from the possible values:<br><input type="checkbox"/> Hold<br><input type="checkbox"/> Release   |
| Hold Status Type             | Shows the type of hold indicator from the possible values:<br><input type="checkbox"/> Party hold  |

| Hold/Release Instruction  |  |
|---------------------------|--|
|                           | <input type="checkbox"/> CSD hold<br><input type="checkbox"/> CSD validation hold<br><input type="checkbox"/> CoSD hold  |
| <b>Buttons</b>            |  |
| Revisions                 | <p>This function enables you to display the revisions of the selected hold/release instruction.</p> <p>Next screen:</p> <ul style="list-style-type: none"> <li><input type="checkbox"/> <i>Revisions/audit trail – list</i> screen [▶ 661]</li> </ul>  |
| Related Outbound Messages | <p>This function enables you to display the outbound messages related to the hold/release instruction.</p> <p>In case the hold/release instruction is linked to more than one outbound message, the <i>outbound messages - search/list</i> screen is displayed.</p> <p>In case the query returns only one valid message, the <i>outbound message – details</i> screen is displayed directly.</p> <p>Next screen:</p> <ul style="list-style-type: none"> <li><input type="checkbox"/> <i>Outbound messages – search/list</i> screen [▶ 645]</li> <li><input type="checkbox"/> <i>Outbound message – details</i> screen [▶ 653]</li> </ul> |
| Related Inbound Messages  | <p>This function enables you to display the inbound messages related to the hold/release instruction.</p> <p>In case the hold/release instruction is linked to more than one inbound message, the <i>inbound messages - search/list</i> screen is displayed.</p> <p>In case the query returns only one valid message, the <i>inbound message – details</i> screen is displayed directly.</p> <p>Next screen:</p> <ul style="list-style-type: none"> <li><input type="checkbox"/> <i>Inbound messages – search/list</i> screen [▶ 628]</li> <li><input type="checkbox"/> <i>Inbound message – details</i> screen [▶ 635]</li> </ul>       |
| Status History            | <p>This function enables you to display the status history of the hold/release instruction.</p> <p>Next screen:</p> <ul style="list-style-type: none"> <li><input type="checkbox"/> <i>Status history – details</i> screen [▶ 266]</li> </ul>  |

## 2.2.2.10 Hold/Release Instruction - New Screen

|                         |  |
|-------------------------|--|
| <b>Context of Usage</b> | <p>This screen contains a number of fields regarding hold/release instructions. You can enter new data. Afterwards you can proceed further by clicking on the buttons below.</p> <p>You can use this screen either in 2-eyes or in 4-eyes mode.</p> <p>This screen is not relevant for CB users.</p>   |
| <b>Screen Access</b>    | <ul style="list-style-type: none"><li><input type="checkbox"/> <i>Securities &gt;&gt; Settlement &gt;&gt; Settlement Instructions &gt;&gt; Settlement instructions – search/list</i> screen &gt;&gt; Click on the <i>search</i> and/or <i>details</i> button &gt;&gt; <i>Settlement instruction - details</i> screen &gt;&gt; Click on the <i>hold/release</i> button</li></ul>  |
| <b>Privileges</b>       | <p>To use this screen, you need the following privileges [<a href="#">▶ 881</a>]:</p> <ul style="list-style-type: none"><li><input type="checkbox"/> Party hold settlement instruction on a securities account or on behalf of an external CSD</li><li><input type="checkbox"/> CSD hold settlement instruction either on a securities account or on behalf of the CSD in T2S</li><li><input type="checkbox"/> Release party hold settlement instruction on a securities account or on behalf of an external CSD</li><li><input type="checkbox"/> Release party hold auto-collateralisation instruction on a securities account</li><li><input type="checkbox"/> Release CSD hold settlement instruction either on a securities account or on behalf of the CSD in T2S</li><li><input type="checkbox"/> Release CSD validation hold settlement instruction either on a securities account or on behalf of the CSD in T2S</li><li><input type="checkbox"/> Release CoSD hold settlement instruction on behalf of administering party</li><li><input type="checkbox"/> Hold non-modifiable instructions on behalf of the instructing party of the underlying settlement instruction</li><li><input type="checkbox"/> Release non-modifiable instructions on behalf of the instructing party of the underlying settlement instruction</li></ul> |
| <b>References</b>       | <p><b>User Instructions Part</b></p> <p>This screen is part of the following business scenarios:</p> <ul style="list-style-type: none"><li><input type="checkbox"/> Put a settlement instruction on CSD hold [<a href="#">▶ 715</a>]</li><li><input type="checkbox"/> Put a settlement instruction on party hold [<a href="#">▶ 713</a>]</li><li><input type="checkbox"/> Release a settlement instruction from CoSD hold [<a href="#">▶ 722</a>]</li><li><input type="checkbox"/> Release a settlement instruction from CSD hold [<a href="#">▶ 720</a>]</li><li><input type="checkbox"/> Release a settlement instruction from CSD validation hold [<a href="#">▶ 724</a>]</li><li><input type="checkbox"/> Release a settlement instruction from party hold [<a href="#">▶ 717</a>]</li><li><input type="checkbox"/> Partially release a settlement instruction from party hold [<a href="#">▶ 718</a>]</li></ul>   |

### Business Functionality Document

This screen corresponds to the following business function:

- Hold/release instruction (T2S.GUI.SESE.INX.0060)

### Screenshot

Illustration 49: Hold/release instruction - new screen

### Field Description

| Hold / Release Instruction |   |
|----------------------------|---|
| Referenced Instruction     |   |
| Actor Reference            | Shows the identification of the referenced settlement instruction assigned by the T2S actor.<br>References for error messages [ 967]:<br><input type="checkbox"/> MVCP004<br><input type="checkbox"/> MVRI591<br><input type="checkbox"/> MVRI593   |
| T2S Reference              | Shows the identification of the referenced settlement instruction assigned by T2S.<br>References for error messages [ 967]:<br><input type="checkbox"/> MVCP004<br><input type="checkbox"/> MVRI591<br><input type="checkbox"/> MVRI593<br><input type="checkbox"/> MVRI555<br><input type="checkbox"/> MVRI575 |

| Hold / Release Instruction   |  |
|------------------------------|--|
|                              | <input type="checkbox"/> MVRI584   |
| Securities Account Number    | <p>Shows the securities account of the referenced settlement instruction.</p> <p>References for error messages [ 967]:</p> <input type="checkbox"/> MVCP019<br><input type="checkbox"/> MVCP020<br><input type="checkbox"/> MVCP044<br><input type="checkbox"/> MVCP106<br><input type="checkbox"/> MVCP107<br><input type="checkbox"/> MVCP111<br><input type="checkbox"/> MVCP112<br><input type="checkbox"/> MVCP113                          |
| Securities Account Owner BIC | Shows the BIC of the owner of the securities account of the referenced settlement instruction.   |
| Externally Matched           | Shows whether the settlement instruction was sent to T2S already matched or not.   |
| General                      |  |
| Instructing Party Parent BIC | <p>Select the parent BIC of the instructing party from the drop-down menu or search via the <i>magnifier</i> icon.</p> <p>Required format is: max. 11 characters (SWIFT-x)</p> <p>References for error messages [ 967]:</p> <input type="checkbox"/> MVCP121<br><input type="checkbox"/> MCVV109<br><input type="checkbox"/> MCVV233<br><input type="checkbox"/> MVDC026<br><input type="checkbox"/> MVRI584<br><input type="checkbox"/> MVRI595 |
| Instructing Party BIC        | <p>Select the BIC of the instructing party of the hold/release instruction from the drop-down menu or search via the <i>magnifier</i> icon.</p> <p>In case the instructing party is not entered, the instructing party informed to the back end module will be the party you belong to. If the 'Instructing Party Parent BIC' is filled in, the 'Instructing Party BIC' has to be filled in too.</p>   |

| Hold / Release Instruction            |   |
|---------------------------------------|---|
|                                       | <p>Required format is: max. 11 characters (SWIFT-x)</p> <p>References for error messages [ ▶ 967]:</p> <ul style="list-style-type: none"> <li><input type="checkbox"/> MVCP121</li> <li><input type="checkbox"/> MVCV109</li> <li><input type="checkbox"/> MVCV233</li> <li><input type="checkbox"/> MVDC026</li> <li><input type="checkbox"/> MVRI584</li> <li><input type="checkbox"/> MVRI595</li> </ul> <p>In case the instructing party is not entered, the instructing party informed to the back end module will be the party you belong to. If the 'Instructing Party BIC' is filled in, the 'Instructing Party Parent BIC' has to be filled in too.</p>  |
| Hold/Release Counterparty Instruction | <p>Select if you want to hold/release both legs of the settlement instruction.</p> <p>References for error messages [ ▶ 967]:</p> <ul style="list-style-type: none"> <li><input type="checkbox"/> MVCP106</li> <li><input type="checkbox"/> MVCP107</li> <li><input type="checkbox"/> MVCP111</li> <li><input type="checkbox"/> MVCP112</li> <li><input type="checkbox"/> MVCP113</li> <li><input type="checkbox"/> MVCP114</li> <li><input type="checkbox"/> MVCP115</li> <li><input type="checkbox"/> MVCP116</li> <li><input type="checkbox"/> MVCP117</li> <li><input type="checkbox"/> MVCP118</li> </ul> <p>If the referenced settlement instruction is not an already matched instruction or the actor reference is empty the field is greyed out.</p> |
| Hold / Release                        |   |
| <b>Current Hold Status</b>            |   |
| Party Hold Status                     | Shows the current status of the party hold of the referenced settlement instruction as set by the T2S party.  |
| CSD Hold Status                       | Shows the current CSD hold status of the referenced settlement instruction as set by the CSD.   |



| Hold / Release Instruction |   |
|----------------------------|---|
| CSD Validation Hold Status | <p>Shows the current CSD validation hold status of the referenced settlement instruction.</p> <p>When the settlement instruction fulfills one market-specific restriction which is configured in the T2S reference data table, this attribute has the value:</p> <ul style="list-style-type: none"><li><input type="checkbox"/> Yes</li><li><input type="checkbox"/> No</li></ul> <p>References for error messages [ ▶ 967]:</p> <ul style="list-style-type: none"><li><input type="checkbox"/> MMPR207</li><li><input type="checkbox"/> MVRI575</li></ul>  |
| CoSD Hold Status           | <p>Shows the current CoSD hold status of the referenced settlement instruction.</p> <p>When the settlement instruction fulfills a CoSD rule set by an administering party, this attribute has the value:</p> <ul style="list-style-type: none"><li><input type="checkbox"/> Yes</li><li><input type="checkbox"/> No</li></ul> <p>References for error messages [ ▶ 967]:</p> <ul style="list-style-type: none"><li><input type="checkbox"/> MVRI575</li><li><input type="checkbox"/> MVRI593</li></ul>  |
| Hold Types                 |   |
| Party Hold                 | <p>Select the party hold that allows you to send a hold/release instruction to T2S in order to put the referenced instruction on party hold.</p> <p>This field is greyed out in case the referenced instruction is already on 'Party Hold' or you have not the privileges to perform such an operation.</p> <p>References for error messages [ ▶ 967]:</p> <ul style="list-style-type: none"><li><input type="checkbox"/> MMHI104</li><li><input type="checkbox"/> MMHI105</li><li><input type="checkbox"/> MVCP019</li><li><input type="checkbox"/> MVCP046</li><li><input type="checkbox"/> MVCP093</li><li><input type="checkbox"/> MVCP106</li><li><input type="checkbox"/> MVCP114</li></ul> |

| Hold / Release Instruction |   |
|----------------------------|---|
|                            | <input type="checkbox"/> MVCP116<br><input type="checkbox"/> MMPR207  |
| CSD Hold                   | <p>Select the CSD hold allows you to send a hold/release instruction to T2S in order to put the referenced instruction on CSD hold.</p> <p>This field is greyed out in case the referenced instruction is already on 'CSD Hold' or you have not the privileges to perform such an operation.</p> <p>References for error messages [ ▶ 967]:</p> <input type="checkbox"/> MMHI104<br><input type="checkbox"/> MMHI105<br><input type="checkbox"/> MVCP020<br><input type="checkbox"/> MVCP021<br><input type="checkbox"/> MVCP046<br><input type="checkbox"/> MVCP107<br><input type="checkbox"/> MVCP115<br><input type="checkbox"/> MVCP117<br><input type="checkbox"/> MMPR207    |
| Release Types              |   |
| Party Release              | <p>Select the party release allows you to send a hold/release instruction to T2S in order to release the referenced instruction which has been previously put on party hold.</p> <p>This field is greyed out in case the referenced instruction is not on 'Party Hold' or you have not the privileges to perform such an operation.</p> <p>References for error messages [ ▶ 967]:</p> <input type="checkbox"/> MMRI201<br><input type="checkbox"/> MMRI202<br><input type="checkbox"/> MMRI204<br><input type="checkbox"/> MVCP022<br><input type="checkbox"/> MVCP047<br><input type="checkbox"/> MVCP094<br><input type="checkbox"/> MVCP111<br><input type="checkbox"/> MVCP129 |

| Hold / Release Instruction |   |
|----------------------------|---|
|                            | <input type="checkbox"/> MVRI591  |
| CSD Release                | <p>Select the CSD release allows you to send a hold/release instruction to T2S in order to release the referenced instruction which has been previously put on CSD hold.</p> <p>This field is greyed out in case the referenced instruction is not on 'CSD Hold' or you have not the privileges to perform such an operation.</p> <p>References for error messages [ ▶ 967]:</p> <ul style="list-style-type: none"> <li><input type="checkbox"/> MMRI201</li> <li><input type="checkbox"/> MMRI202</li> <li><input type="checkbox"/> MMRI204</li> <li><input type="checkbox"/> MVCP023</li> <li><input type="checkbox"/> MVCP025</li> <li><input type="checkbox"/> MVCP047</li> <li><input type="checkbox"/> MVCP112</li> <li><input type="checkbox"/> MVRI591</li> </ul>   |
| CSD Validation Release     | <p>Select the CSD validation release allows you to send a hold/release instruction to T2S in order to release the referenced instruction which has been previously put on CSD validation hold by the system.</p> <p>You cannot put an instruction on 'CSD Validation Hold'. This operation can only be performed by the system.</p> <p>This field is greyed out in case the referenced instruction is not on 'CSD Validation Hold' or you have not the privileges to perform such an operation.</p> <p>References for error messages [ ▶ 967]:</p> <ul style="list-style-type: none"> <li><input type="checkbox"/> MMRI201</li> <li><input type="checkbox"/> MMRI202</li> <li><input type="checkbox"/> MMRI204</li> <li><input type="checkbox"/> MVCP024</li> <li><input type="checkbox"/> MVCP026</li> <li><input type="checkbox"/> MVCP047</li> <li><input type="checkbox"/> MVCP113</li> <li><input type="checkbox"/> MVCP118</li> </ul> |

| Hold / Release Instruction |  |
|----------------------------|--|
|                            | <input type="checkbox"/> MVRI591   |
| CoSD Release               | <p>Select the CoSD release allows you to send a hold/release instruction to T2S in order to release the referenced instruction which has been previously put on 'CoSD Hold' by the system.</p> <p>References for error messages [ ▶ 967]:</p> <ul style="list-style-type: none"> <li><input type="checkbox"/> MMPR201</li> <li><input type="checkbox"/> MMPR202</li> <li><input type="checkbox"/> MMPR203</li> <li><input type="checkbox"/> MMPR204</li> <li><input type="checkbox"/> MMPR207</li> <li><input type="checkbox"/> MMPR208</li> <li><input type="checkbox"/> MMPR209</li> <li><input type="checkbox"/> MMRI201</li> <li><input type="checkbox"/> MMRI202</li> <li><input type="checkbox"/> MMRI204</li> <li><input type="checkbox"/> MVCP047</li> <li><input type="checkbox"/> MVRI584</li> <li><input type="checkbox"/> MVRI591</li> <li><input type="checkbox"/> MVRI593</li> <li><input type="checkbox"/> MVRI595</li> </ul> |
| CoSD Rule Identification   | <p>Enter the reference of the CoSD rule to be released by the hold/release instruction.</p> <p>Required format is: max. 35 characters (SWIFT-x)</p> <p>In case the referenced instruction is not on 'CoSD Hold', this field must be greyed out.</p> <p>References for error messages [ ▶ 967]:</p> <ul style="list-style-type: none"> <li><input type="checkbox"/> MMPR203</li> <li><input type="checkbox"/> MMPR204</li> <li><input type="checkbox"/> MMPR208</li> <li><input type="checkbox"/> MMPR209</li> <li><input type="checkbox"/> MVCP043</li> <li><input type="checkbox"/> MVRI571</li> </ul>  |

| Hold / Release Instruction |  |
|----------------------------|--|
|                            | <input type="checkbox"/> MVRI572<br><input type="checkbox"/> MVRI584<br><input type="checkbox"/> MVRI595   |
| Quantity                   |  |
| Released Quantity          | <p>Enter the quantity to be released if you want to partially release a delivering settlement instruction which has been previously put on party hold.</p> <p>This field is only available in case the released instruction is on 'Party Hold' and it is the delivering side of the transaction. If any other hold applies to the instruction, the released instruction is the receiving part of the transaction, it is unmatched, it is an internally generated instruction or its intended settlement date has not been reached, the field is greyed out.</p> <p>Required format is:</p> <p>For settlement type = Unit, max.15 digit(s) incl. decimal point (thereof max. 14 decimal places)</p> <p>For settlement type = Face amount, max. 15 digit(s) incl. decimal point (thereof max. 5 decimal places)</p> <p>References for error messages: [▶ 967]</p> <input type="checkbox"/> MVRI598<br><input type="checkbox"/> MVRI599<br><input type="checkbox"/> MVRI600<br><input type="checkbox"/> MVRI601<br><input type="checkbox"/> MVRI602<br><input type="checkbox"/> MVRI603<br><input type="checkbox"/> MVRI604<br><input type="checkbox"/> SPSA001<br><input type="checkbox"/> SPSA002<br><input type="checkbox"/> SPSA019 |
|                            | <p>In case the released quantity is not populated and the party release is selected, the party release instruction will be for the total quantity of the settlement instruction, or for the remaining to be settled quantity in case the settlement instruction has been already partially settled.</p>  |

**Buttons****Submit**

This function enables you to create a new hold/release instruction. Upon clicking on the *submit* button you will be asked to enter your PIN for digital signature purposes (NRO). With the entry of the PIN, T2S attaches a digital signature to the instruction entered by the T2S actor.

Next screen:

*Hold/Release Instruction – New screen*

References for error messages [ ▶ 967]:

- MMHI101
- MMHI102
- MMHI104
- MMHI105
- MMPR201
- MMPR202
- MMPR203
- MMPR204
- MMPR207
- MMPR208
- MMPR209
- MMRI201
- MMRI202
- MMRI204
- MVCP004
- MVCP019
- MVCP020
- MVCP021
- MVCP022
- MVCP023
- MVCP024
- MVCP025
- MVCP026
- MVCP043
- MVCP044

- MVCP046
- MVCP047
- MVCP093
- MVCP094
- MVCP106
- MVCP107
- MVCP111
- MVCP112
- MVCP113
- MVCP114
- MVCP115
- MVCP116
- MVCP117
- MVCP118
- MVCP121
- MVCP129
- MCVV109
- MCVV233
- MVDC026
- MVRI555
- MVRI556
- MVRI571
- MVRI572
- MVRI575
- MVRI584
- MVRI591
- MVRI593
- MVRI595
- MVRI598
- MVRI599
- MVRI600
- MVRI601

|        |  |
|--------|--|
|        | <input type="checkbox"/> MVRI602<br><input type="checkbox"/> MVRI603<br><input type="checkbox"/> MVRI604<br><input type="checkbox"/> SPSA001<br><input type="checkbox"/> SPSA002<br><input type="checkbox"/> SPSA019 |
| Cancel | <p>This function enables you to cancel the process and return to the previous screen.</p> <p>Next screen:</p> <input type="checkbox"/> <i>Settlement instruction – details</i> screen [▶ 191]                        |
| Reset  | <p>This function enables you to set all fields to default value and blanks out all optional fields.</p> <p>Next screen:</p> <input type="checkbox"/> <i>Hold/release instruction – new</i> screen                    |

## 2.2.2.11 Intra-Position Movements - Search/List Screen

### Context of Usage

This screen contains a number of search fields. By inputting the relevant data, you can search for settlement restrictions on securities. The search results will be displayed in a list. After selecting an entry, you can proceed further by clicking on the buttons below.

This screen is not relevant for CB users.

### Screen Access

Securities >> Settlement >> Intra-Position Movements

### Privileges

To use this screen, you need the following privilege [▶ 888]:

Intra-position movements query

### References

#### User Instructions Part

This screen is part of the following business scenarios:

- Add a link for a settlement restriction on securities [▶ 757]
- Amend the priority for a settlement restriction on securities [▶ 760]
- Cancel a settlement restriction on securities [▶ 773]
- Copy a settlement restriction on securities [▶ 747]
- Enter a Settlement Restriction on Securities [▶ 745]
- Remove a link for a settlement restriction on securities [▶ 762]
- View settlement restriction on securities details [▶ 750]



### Business Functionality Document

This screen corresponds to the following business functions:

- Query instruction (T2S.GUI.SESE.INX.0010)
- Display instruction list (T2S.GUI.SESE.INX.0020)

### Screenshot

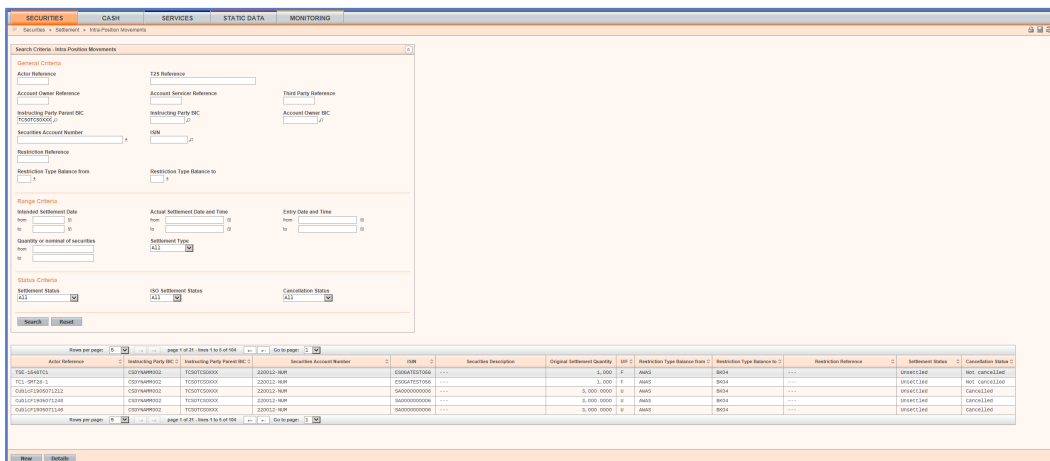

Illustration 50: Intra-position movements - search/list screen

### Field Description

| Intra-Position Movements – Search Criteria |  |
|--|--|
| Actor Reference                            | Enter the identification of the reference assigned for a settlement restriction by the T2S actor.<br><br>Required format is: max. 16 characters (SWIFT-x)  |
| T2S Reference                              | Enter the identification of the reference assigned for a settlement restriction on securities by T2S.<br><br>Required format is: max. 16 characters (SWIFT-x)  |
| Securities Account Owner Reference         | Enter the reference assigned by the T2S party to the settlement restriction.<br><br>Required format is: max. 16 characters (SWIFT-x)   |
| Securities Account Servicer Reference      | Enter the reference assigned by the CSD to the settlement restriction on cash.<br><br>Required format is: max. 16 characters (SWIFT-x)   |
| Third Party Reference                      | Enter the reference assigned by a third party to the instruction.<br><br>Required format is: max. 16 characters (SWIFT-x)  |
| Instructing Party Parent BIC               | Enter the parent BIC of the instructing party or search via the <i>magnifier</i> icon.<br><br>Required format is: max. 11 characters (SWIFT-x)<br><br>References for error messages [ ▶ 1038]:<br><br><input type="checkbox"/> QMPC048 |

| Intra-Position Movements – Search Criteria |  |
|--|--|
|  | <input type="checkbox"/> QMPC084   |
| Instructing Party BIC                      | <p>Enter the BIC of the instructing party or search via the <i>magnifier</i> icon.</p> <p>Required format is: max. 11 characters (SWIFT-x)</p> <p>References for error messages [ ▶ 1038]:</p> <input type="checkbox"/> QMPC032<br><input type="checkbox"/> QMPC084  |
| Securities Account Owner BIC               | <p>Enter the BIC of the account owner.</p> <p>Required format is: max. 11 characters (SWIFT-x)</p> <p>Reference for error message [ ▶ 1038]:</p> <input type="checkbox"/> QMPC032  |
| Securities Account Number                  | <p>Enter the number of the securities account</p> <p>Required format is: max. 35 characters (SWIFT-x)</p> <p>Reference for error message [ ▶ 1038]:</p> <input type="checkbox"/> QMPC030   |
| ISIN                                       | <p>Enter the ISIN of the securities.</p> <p>Required format is: max. 12 characters (SWIFT-x)</p> <p>Reference for error message [ ▶ 1038]:</p> <input type="checkbox"/> QMPC018  |
| Restriction Reference                      | <p>Enter the unique identification of a restricted securities position.</p> <p>Required format is: max. 16 characters (SWIFT-x)</p>  |
| Restriction Type Balance from              | <p>Select the restriction type code of the securities position from which the securities have to be restricted/ unrestricted from the drop-down menu.</p> <p>Reference for error message [ ▶ 1038]</p> <input type="checkbox"/> IIMP102 <p>The securities balance type of 'Balance from' must be different from the securities balance type of 'Balance to'.</p> |
| Restriction Type Balance to                | <p>Select the restriction type code of the securities position to which the securities have to be restricted/ unrestricted from the drop-down menu.</p> <p>Reference for error message [ ▶ 1038]:</p> <input type="checkbox"/> IIMP102   |

| Intra-Position Movements – Search Criteria |  |
|--|--|
|  | The securities balance type of 'Balance to' must be different from the securities balance type of 'Balance from'.  |
| Intended Settlement Date - from            | Enter the lower bound of the search range for the intended settlement date or use the <i>calendar</i> icon.<br>Required format is: YYYY-MM-DD<br>Reference for error message [ ▶ 1038]:<br><input type="checkbox"/> QMPC012  |
| Intended Settlement Date - to              | Enter the upper bound of the search range for the intended settlement date or use the <i>calendar</i> icon.<br>Required format is: YYYY-MM-DD<br>Reference for error message [ ▶ 1038]:<br><input type="checkbox"/> QMPC012  |
| Actual Settlement Date - from              | Enter the lower bound of the search range for the actual settlement date or use the <i>calendar</i> icon.<br>Required format is: YYYY-MM-DD hh:mm:ss<br>References for error messages [ ▶ 1038]:<br><input type="checkbox"/> QMPC013<br><input type="checkbox"/> QMPC014 |
| Actual Settlement Date - to                | Enter the upper bound of the search range for the actual settlement date or use the <i>calendar</i> icon.<br>Required format is: YYYY-MM-DD hh:mm:ss<br>Reference for error message [ ▶ 1038]:<br><input type="checkbox"/> QMPC014                                       |
| Entry Date and Time – from                 | Enter the lower bound of the search range for the entry date and time or use the <i>calendar</i> icon.<br>Required format is: YYYY-MM-DD hh:mm:ss<br>References for error messages [ ▶ 1038]:<br><input type="checkbox"/> QMPC015<br><input type="checkbox"/> QMPC073    |
| Entry Date and Time – to                   | Enter the upper bound of the search range for the entry date and time or use the <i>calendar</i> icon.<br>Required format is: YYYY-MM-DD hh:mm:ss<br>References for error messages [ ▶ 1038]:<br><input type="checkbox"/> QMPC015  |

| Intra-Position Movements – Search Criteria |   |
|--|---|
|  | <input type="checkbox"/> QMPC095  |
| Quantity or Nominal of Securities – from   | <p>Enter the lower bound of the search range for the quantity or nominal of securities.</p> <p>Required format is: max. 18,6 digits incl. decimal point</p> <p>Reference for error message [ ▶ 1038]:</p> <input type="checkbox"/> QMPC006  |
| Quantity or Nominal of Securities – to     | <p>Enter the upper bound of the search range for the quantity or nominal of securities.</p> <p>Required format is: max. 18,6 digits incl. decimal point</p> <p>Reference for error message [ ▶ 1038]:</p> <input type="checkbox"/> QMPC006  |
| Settlement Type                            | <p>Select the type of settlement foreseen for the securities from the possible values:</p> <input type="checkbox"/> Unit<br><input type="checkbox"/> Face amount  |
| Settlement Status                          | <p>Select the settlement status of the settlement restriction from the possible values:</p> <input type="checkbox"/> All (default value)<br><input type="checkbox"/> Unsettled<br><input type="checkbox"/> Settled<br><input type="checkbox"/> Partially settled  |
| ISO Settlement status                      | <p>Select the settlement status of the settlement restriction from the possible values:</p> <input type="checkbox"/> All (default value)<br><input type="checkbox"/> Pending<br><input type="checkbox"/> Failing<br><p>If value 'Settlement Status' field is set to 'Settled' or 'Cancellation Status' field is set to 'Cancelled', this field is disabled.</p> |
| Cancellation Status                        | <p>Select the cancellation status of the settlement restriction from the possible values:</p> <input type="checkbox"/> All (default value)<br><input type="checkbox"/> Cancelled<br><input type="checkbox"/> Not cancelled  |

| Intra-Position Movements – Search Criteria |  |
|--|--|
| Intra-Position Movements - List            |  |
| Actor Reference                            | Shows the identification of the reference assigned for a settlement restriction by the instructing party.  |
| Instructing Party BIC                      | Shows the BIC of the instructing party.  |
| Instructing Party Parent BIC               | Shows the parent BIC of the instructing party.   |
| Securities Account Number                  | Shows the number of the securities account.  |
| ISIN                                       | Shows the ISIN of the securities.  |
| Securities Description                     | Shows the textual description of a security instrument.  |
| Original Quantity                          | Shows the quantity of financial instrument in units, original face amount or current face amount.  |
| Settlement Unit                            | Shows the quantity type of the original settlement quantity from the possible values: <ul style="list-style-type: none"> <li><input type="checkbox"/> Units</li> <li><input type="checkbox"/> Face amount</li> </ul>   |
| Restriction Type – Balance from            | Shows the code specified by the CSD to identify the restriction.   |
| Restriction Type - Balance to              | Shows the code specified by the CSD to identify the restriction.   |
| Restriction Reference                      | Shows the unique identification of a restricted securities position.   |
| Settlement Status                          | Shows the current settlement status of the settlement restriction from the possible values: <ul style="list-style-type: none"> <li><input type="checkbox"/> Unsettled</li> <li><input type="checkbox"/> Settled</li> <li><input type="checkbox"/> Partially settled</li> </ul> |
| Cancellation Status                        | Shows the current cancellation status of the settlement restriction from the possible values: <ul style="list-style-type: none"> <li><input type="checkbox"/> Cancelled</li> <li><input type="checkbox"/> Not cancelled</li> </ul>   |

**Buttons**

|         |   |
|---------|---|
| Search  | <p>This function enables you to start a search according to the criteria entered. The results are displayed in a list on the same screen.</p> <p>If the search retrieves a single record, the <i>details</i> screen is displayed directly.</p> <p>Next screens:</p> <ul style="list-style-type: none"><li><input type="checkbox"/> <i>Intra-position movements – search/list</i> screen</li><li><input type="checkbox"/> <i>Intra-position movement – details</i> screen [▶ 143]</li></ul> <p>References for error messages [▶ 1038]:</p> <ul style="list-style-type: none"><li><input type="checkbox"/> QMPC006</li><li><input type="checkbox"/> QMPC012</li><li><input type="checkbox"/> QMPC013</li><li><input type="checkbox"/> QMPC014</li><li><input type="checkbox"/> QMPC015</li><li><input type="checkbox"/> QMPC018</li><li><input type="checkbox"/> QMPC030</li><li><input type="checkbox"/> QMPC032</li><li><input type="checkbox"/> QMPC048</li><li><input type="checkbox"/> QMPC073</li><li><input type="checkbox"/> QMPC084</li><li><input type="checkbox"/> QMPC095</li></ul> |
| Reset   | <p>This function enables you to set default search criteria and blanks out all optional criteria</p> <p>Next screen:</p> <ul style="list-style-type: none"><li><input type="checkbox"/> <i>Intra-position movements– search/list</i> screen</li></ul>   |
| New     | <p>This function enables you to create a new settlement restriction on securities.</p> <p>Next screen:</p> <ul style="list-style-type: none"><li><input type="checkbox"/> <i>Intra-position movement – new</i> screen [▶ 150]</li></ul>   |
| Details | <p>This function enables you to display the details of the selected settlement restriction on securities.</p> <p>Next screen:</p> <ul style="list-style-type: none"><li><input type="checkbox"/> <i>Intra-position movement – details</i> screen [▶ 143]</li></ul>  |

## 2.2.2.12 Intra-Position Movement - Details Screen

|                         |  |
|-------------------------|--|
| <b>Context of Usage</b> | <p>This screen displays detailed information on the selected settlement restriction on securities. You can check the data and proceed further by clicking on the buttons below.</p> <p>This screen is not relevant for CB users.</p>   |
| <b>Screen Access</b>    | <ul style="list-style-type: none"><li>□ <code>Securities &gt;&gt; Settlement &gt;&gt; Intra-Position Movements &gt;&gt; Intra-position movements – search/list</code> screen &gt;&gt; Click on the <i>search</i> and/or <i>details</i> button</li></ul>  |
| <b>Privileges</b>       | <p>To use this screen you need the following privilege:</p> <ul style="list-style-type: none"><li>□ Intra-position movements query</li></ul>   |
| <b>References</b>       | <p><b>User Instructions Part</b></p> <p>This screen is part of the following business scenarios:</p> <ul style="list-style-type: none"><li>□ Add a link for a settlement restriction on securities [▶ 757]</li><li>□ Amend the priority for a settlement restriction on securities [▶ 760]</li><li>□ Cancel a settlement restriction on securities [▶ 773]</li><li>□ Copy a settlement restriction on securities [▶ 747]</li><li>□ Remove a link for a settlement restriction on securities [▶ 762]</li><li>□ View settlement restriction on securities details [▶ 750]</li></ul> <p><b>Business Functionality Document</b></p> <p>This screen corresponds to the following business function:</p> <ul style="list-style-type: none"><li>□ Display instruction details (T2S.GUI.SESE.INX.0030)</li></ul> |

Screenshot

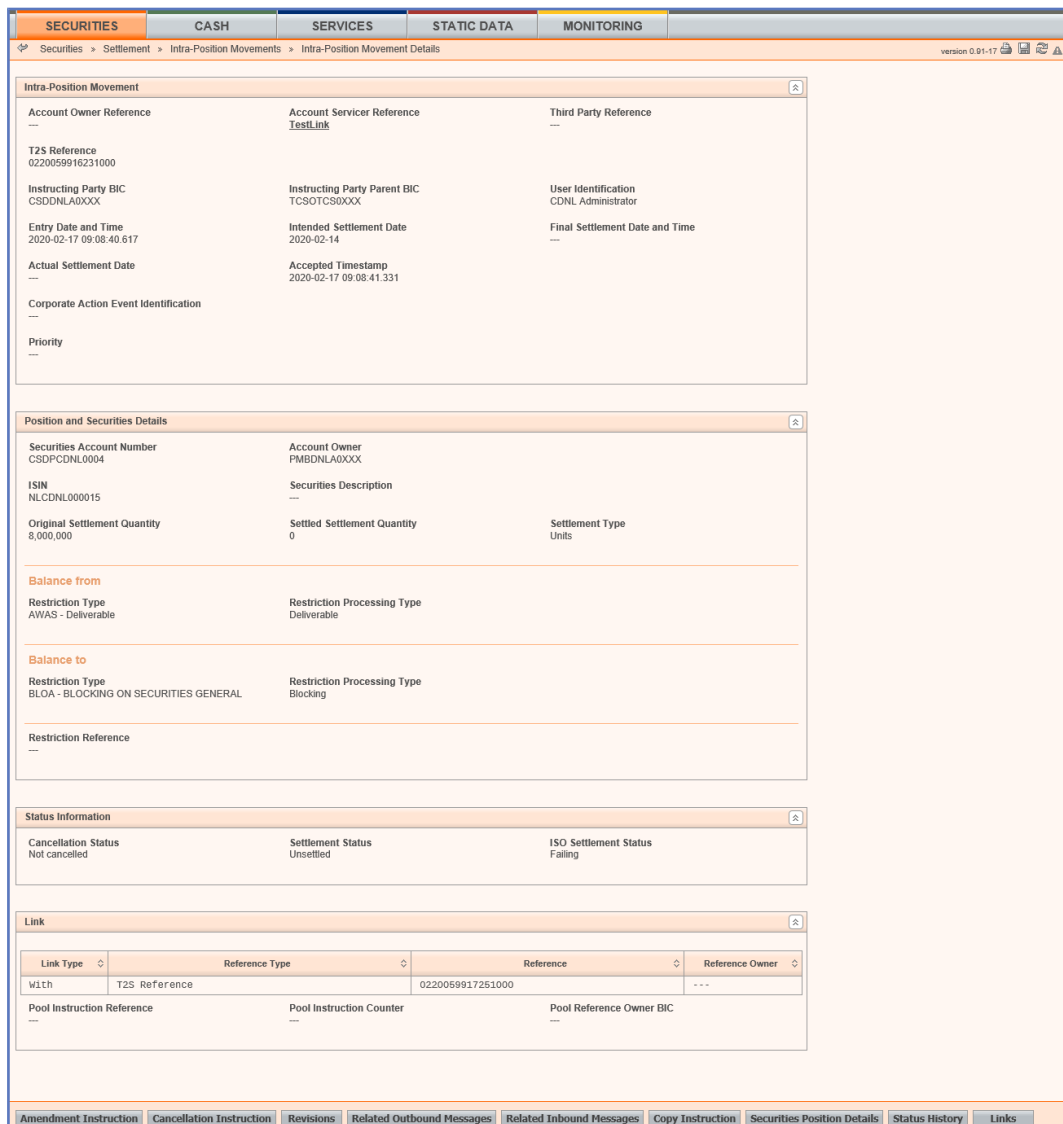

Illustration 51: Intra-position movement - details screen

Field

Description

| Intra-Position Movement               |  |
|---------------------------------------|--|
| Securities Account Owner Reference    | Shows the reference assigned by the T2S party to the settlement restriction.<br><br>Only one of the three references exists. The reference in bold and underlined font is the actor reference owned by the instructing party.        |
| Securities Account Servicer Reference | Shows the reference assigned by the CB to the settlement restriction on securities.<br><br>Only one of the three references exists. The reference in bold and underlined font is the actor reference owned by the instructing party. |
| Third Party Reference                 | Shows the reference assigned by a third party to the instruction.  |



| Intra-Position Movement               |  |
|---------------------------------------|--|
|                                       | Only one of the three references exists. The reference in bold and underlined font is the actor reference owned by the instructing party.  |
| T2S Reference                         | Shows the identification of the reference assigned for a settlement restriction on securities by T2S.  |
| Instructing Party BIC                 | Shows the BIC of the instructing party.  |
| Instructing Party Parent BIC          | Shows the parent BIC of the instructing party.   |
| User Identification                   | Shows user identification of the sending party.  |
| Entry Date and Time                   | Shows the date and time when the instruction has entered in T2S.<br>Displayed format is: YYYY-MM-DD hh:mm:ss:µsµsµsµsµs  |
| Intended Settlement Date              | Shows the date at which the instruction becomes eligible to be submitted to settlement.<br>Displayed format is: YYYY-MM-DD   |
| Final Settlement Date and Time        | Shows the business date and the calendar time when the settlement restriction has been totally settled.<br>Displayed format is: YYYY-MM-DD hh:mm:ss:µsµsµsµsµs   |
| Actual Settlement Date and Time       | Shows the business date and the calendar time when the settlement restriction has been settled or totally settled.<br>Displayed format is: YYYY-MM-DD hh:mm:ss:µsµsµsµsµs  |
| Accepted Timestamp (SF1)              | Shows the accepted timestamp of the settlement restriction.<br>Displayed format is: YYYY-MM-DD hh:mm:ss:µsµsµsµsµs   |
| Corporate Action Event Identification | Shows the identification assigned by the account servicer to unambiguously identify a corporate action event.  |
| Priority                              | Shows the level of priority assigned by T2S or by the T2S actor from the possible values:<br><input type="checkbox"/> Normal<br><input type="checkbox"/> High<br><input type="checkbox"/> Top<br><input type="checkbox"/> Reserved |
| Position and Securities Details       |  |
| Securities Account Number             | Shows the securities account of the settlement restriction on securities.  |

| Intra-Position Movement      |   |
|------------------------------|---|
| Securities Account Owner BIC | Shows the BIC of the owner of the securities account.   |
| ISIN                         | Shows the ISIN of the securities account.   |
| Securities Description       | Shows the textual description of a securities account.  |
| Original Settlement Quantity | Shows the total quantity of securities to be settled.   |
| Settled Settlement Quantity  | Shows the settled quantity of securities.   |
| Settlement Type              | Shows the type of settlement foreseen for the securities from the possible values:<br><input type="checkbox"/> Units<br><input type="checkbox"/> Face amount  |
| <b>Balance from</b>          |   |
| Restriction Type             | Shows the code defined in reference data to identify the restriction.   |
| Restriction Processing Type  | Shows the type of processing T2S shall apply for the restriction from the possible values:<br><input type="checkbox"/> Rejection<br><input type="checkbox"/> Reservation<br><input type="checkbox"/> Blocking<br><input type="checkbox"/> Earmarking<br><input type="checkbox"/> Earmarking for auto-collateralisation<br><input type="checkbox"/> Deliverable<br><input type="checkbox"/> Collateralised<br><input type="checkbox"/> CoSD blocking |
| <b>Balance to</b>            |   |
| Restriction Type             | Shows the code defined in reference data to identify the restriction.   |
| Restriction Processing Type  | Shows the type of processing T2S shall apply for the restriction from the possible values:<br><input type="checkbox"/> Rejection<br><input type="checkbox"/> Reservation<br><input type="checkbox"/> Blocking   |

| Intra-Position Movement |   |
|-------------------------|---|
|                         | <input type="checkbox"/> Earmarking<br><input type="checkbox"/> Earmarking for auto-collateralisation<br><input type="checkbox"/> Deliverable<br><input type="checkbox"/> Collateralised<br><input type="checkbox"/> CoSD blocking  |
| Restriction Reference   | Shows the unique identification of a restriction reference.   |
| Status Information      |   |
| Cancellation Status     | Shows the current cancellation status of the settlement restriction from the possible values:<br><input type="checkbox"/> Cancelled<br><input type="checkbox"/> Not cancelled   |
| Settlement Status       | Shows the current settlement status of the settlement restriction from the possible values:<br><input type="checkbox"/> Settled<br><input type="checkbox"/> Partially settled<br><input type="checkbox"/> Unsettled   |
| ISO Settlement Status   | Shows the current ISO settlement status of the settlement restriction from the possible values:<br><input type="checkbox"/> Pending<br><input type="checkbox"/> Failing   |
| Link                    |   |
| Link Type               | Shows the type of link of the instruction your restriction is linked with from the possible values:<br><input type="checkbox"/> After<br><input type="checkbox"/> Before<br><input type="checkbox"/> With<br><input type="checkbox"/> Info  |
| Reference Type          | Shows the reference type of the instruction to be linked/unlinked to from the possible values:<br><input type="checkbox"/> Account owner settlement instruction reference<br><input type="checkbox"/> Account owner settlement instruction reference<br><input type="checkbox"/> Account owner intra balance movement reference |

| Intra-Position Movement    |   |
|----------------------------|---|
|                            | <input type="checkbox"/> Account owner intra position movement reference<br><input type="checkbox"/> Account servicer reference<br><input type="checkbox"/> Third party reference<br><input type="checkbox"/> T2S reference |
| Reference                  | Shows the identification of the instruction to be linked/un-linked to.  |
| Reference Owner            | Shows the BIC of the instructing party of the instruction to be linked/unlinked to.<br><br>This field is only filled in if the 'Reference Type' is set to any value different than 'T2S Reference'.                         |
| Pool Instruction reference | Shows the collective reference identifying a set of messages.   |
| Pool Instruction Counter   | Shows the maximum number of instructions included in the pool.  |
| Pool Reference Owner BIC   | Shows the BIC of the owner of the Pool Instruction Reference  |

## Buttons

| Amendment Instruction    | <p>This function enables you to create a new amendment instruction for your settlement restriction on securities.</p> <p>This button is not available in case any status of the settlement restriction on securities does not allow the creation of the amendment instruction.</p> <p>Next screen:</p> <ul style="list-style-type: none"> <li><input type="checkbox"/> <i>Amendment securities instruction - new</i> screen [▶ 102]</li> </ul>          |
|--------------------------|---|
| Cancellation Instruction | <p>This function enables you to create a new cancellation instruction for your settlement restriction on securities.</p> <p>This button is not available in case any status of the settlement restriction on securities does not allow the creation of the cancellation instruction.</p> <p>Next screen:</p> <ul style="list-style-type: none"> <li><input type="checkbox"/> <i>Cancellation securities instruction - new</i> screen [▶ 116]</li> </ul> |
| Revisions                | <p>This function enables you to display the revisions of the settlement restriction on securities.</p> <p>Next screen:</p> <ul style="list-style-type: none"> <li><input type="checkbox"/> <i>Revisions/audit trail – list</i> screen [▶ 661]</li> </ul>  |

|                             |  |
|-----------------------------|--|
| Related Outbound Messages   | <p>This function enables you to display the outbound messages related to the settlement restriction on securities.</p> <p>In case the settlement restriction on securities is linked to more than 1 outbound message, the <i>outbound messages - search/list</i> screen is displayed.</p> <p>In case the query only returns 1 valid message, the <i>outbound message – details</i> screen is displayed directly.</p> <p>Next screens:</p> <ul style="list-style-type: none"><li><input type="checkbox"/> <i>Outbound messages – search/list</i> screen [ 645]</li><li><input type="checkbox"/> <i>Outbound message – details</i> screen [ ▶ 653]</li></ul> |
| Related Inbound Messages    | <p>This function enables you to display the inbound messages related to the settlement restriction on securities.</p> <p>In case the settlement restriction on securities is linked to more than 1 inbound message, the <i>inbound messages - search/list</i> screen is displayed.</p> <p>In case the query only returns 1 valid message, the <i>inbound message – details</i> screen is displayed directly.</p> <p>Next screens:</p> <ul style="list-style-type: none"><li><input type="checkbox"/> <i>Inbound messages – search/list</i> screen [ ▶ 628]</li><li><input type="checkbox"/> <i>Inbound message – details</i> screen [ ▶ 635]</li></ul>     |
| Copy Instruction            | <p>This function enables you to copy fields to create a new settlement restriction on securities with the same attributes.</p> <p>Next screen:</p> <ul style="list-style-type: none"><li><input type="checkbox"/> <i>Intra-position movement – new</i> screen</li></ul>  |
| Securities Position Details | <p>This function enables you to display the position details related to the settlement restriction on securities.</p> <p>All the position details from the ‘Settlement Restriction on Securities’ are shown, including the restriction type from the ‘Balance From’ and the ‘Balance to’.</p> <p>Next screen:</p> <ul style="list-style-type: none"><li><input type="checkbox"/> <i>Securities position - details</i> screen [ ▶ 173]</li></ul>  |
| Status History              | <p>This function enables you to display the status history of the settlement restriction on securities.</p> <p>Next screen:</p>  |

|       | <input type="checkbox"/> <i>Status history – details</i> screen [ 266]   |
|-------|--|
| Links | <p>This function enables you to display all the links data preventing settlement at the moment when the request is performed.</p> <p>This button is not available in the following cases:</p> <ul style="list-style-type: none"> <li><input type="checkbox"/> Cancellation Status = “cancelled”</li> <li><input type="checkbox"/> Settlement Status=“settled”</li> </ul> <p>Next screen:</p> <ul style="list-style-type: none"> <li><input type="checkbox"/> Links Preventing Settlement-screen</li> </ul> |

### 2.2.2.13 Intra-Position Movement - New Screen

#### Context of Usage

The screen contains a number of fields regarding settlement restrictions on securities (intra-position movement). You can enter new data. Afterwards you can proceed further by clicking on the buttons below.

You can use this screen either in 2-eyes or in 4-eyes mode.

This screen is not relevant for CB users.

#### Screen Access

Securities >> Settlement >> Intra-Position Movements >> *Intra position movements – search/list* screen >> Click on the *new* button

#### Privileges

To use this screen you need the following privileges [▶ 887]:

- Send new instruction using a specific instructing party
- Send new settlement instruction/settlement restriction on securities either on a securities account or on behalf of an external CSD
- Link to an instruction/pool reference belonging to a specific party
- Unblock CoSD securities blocking related to cancelled CoSD settlement instructions on behalf of the relevant CSD in T2S

#### References

##### User Instructions Part

This screen is part of the following business scenarios:

- Enter a settlement restriction on securities [▶ 745]
- Copy a settlement restriction on securities [▶ 747]

##### Business Functionality Document

This screen corresponds to the following business function:

- Add settlement instruction or settlement restriction (T2S.GUI.SESE.INX.0070)

Screenshot

Illustration 52: Intra-position movement - new screen

Field Description

| Intra-Position Movement      |   |
|------------------------------|---|
| Actor Reference*             | Enter the identification of the T2S actor.<br>Required format is: max. 16 characters (SWIFT-x-red)<br>References for error messages [ ▶ 1014]: <ul style="list-style-type: none"> <li><input type="checkbox"/> MVDC003</li> <li><input type="checkbox"/> MVDC005</li> <li><input type="checkbox"/> MVDC007</li> <li><input type="checkbox"/> MVDC015</li> <li><input type="checkbox"/> MVDC017</li> <li><input type="checkbox"/> MVDC019</li> <li><input type="checkbox"/> MVDC022</li> <li><input type="checkbox"/> MVDC023</li> <li><input type="checkbox"/> MVSR705</li> <li><input type="checkbox"/> MVSR708</li> </ul> |
| Instructing Party Parent BIC | Select the parent BIC of the instructing party from the drop-down menu or search via the <i>magnifier</i> icon.   |

| Intra-Position Movement |  |
|-------------------------|--|
|                         | <p>If the instructing party is entered, the instructing party parent must also be entered.</p> <p>Required format is: max. 11 characters (SWIFT-x)</p> <p>References for error messages [ ▶ 1014]:</p> <ul style="list-style-type: none"><li><input type="checkbox"/> MVCP120</li><li><input type="checkbox"/> MVCV110</li><li><input type="checkbox"/> MVCV230</li><li><input type="checkbox"/> MVCV290</li><li><input type="checkbox"/> MVDC003</li><li><input type="checkbox"/> MVDC005</li><li><input type="checkbox"/> MVDC007</li><li><input type="checkbox"/> MVDC015</li><li><input type="checkbox"/> MVDC017</li><li><input type="checkbox"/> MVDC019</li><li><input type="checkbox"/> MVDC022</li><li><input type="checkbox"/> MVDC023</li><li><input type="checkbox"/> MVDC025</li><li><input type="checkbox"/> MVIC310</li><li><input type="checkbox"/> MVIC312</li><li><input type="checkbox"/> MVIC314</li></ul> |
| Instructing Party BIC   | <p>Select the BIC of the instructing party from the drop-down menu or search via the <i>magnifier</i> icon.</p> <p>In case the instructing party is not entered, the instructing party informed to the back end module will be the party you belong to.</p> <p>If the instructing party parent is entered, the instructing party must also be entered.</p> <p>Required format is: max. 11 characters (SWIFT-x)</p> <p>References for error messages [ ▶ 1014]:</p> <ul style="list-style-type: none"><li><input type="checkbox"/> MVCP097</li><li><input type="checkbox"/> MVCP099</li><li><input type="checkbox"/> MVCP120</li><li><input type="checkbox"/> MVCV110</li></ul>   |



| Intra-Position Movement   |   |
|---------------------------|---|
|                           | <ul style="list-style-type: none"> <li><input type="checkbox"/> MVCV230</li> <li><input type="checkbox"/> MVCV290</li> <li><input type="checkbox"/> MVDC003</li> <li><input type="checkbox"/> MVDC005</li> <li><input type="checkbox"/> MVDC007</li> <li><input type="checkbox"/> MVDC015</li> <li><input type="checkbox"/> MVDC017</li> <li><input type="checkbox"/> MVDC019</li> <li><input type="checkbox"/> MVDC022</li> <li><input type="checkbox"/> MVDC023</li> <li><input type="checkbox"/> MVDC025</li> <li><input type="checkbox"/> MVIC310</li> <li><input type="checkbox"/> MVIC312</li> <li><input type="checkbox"/> MVIC314</li> <li><input type="checkbox"/> MVSP210</li> </ul>  |
| Intended Settlement Date* | <p>Enter the date at which the instruction becomes eligible to be submitted to settlement or use the <i>calendar</i> icon.</p> <p>Required format is: YYYY-MM-DD</p> <p>References for error messages [ 1014]:</p> <ul style="list-style-type: none"> <li><input type="checkbox"/> MVCV110</li> <li><input type="checkbox"/> MVCV124</li> <li><input type="checkbox"/> MVCV230</li> <li><input type="checkbox"/> MVCV284</li> <li><input type="checkbox"/> MVCV302</li> <li><input type="checkbox"/> MVCV304</li> <li><input type="checkbox"/> MVIC306</li> <li><input type="checkbox"/> MVIC310</li> <li><input type="checkbox"/> MVIC312</li> <li><input type="checkbox"/> MVLI819</li> <li><input type="checkbox"/> MVLI820</li> <li><input type="checkbox"/> MVLI821</li> <li><input type="checkbox"/> MVLI822</li> </ul> |

| Intra-Position Movement    |   |
|----------------------------|---|
|                            | <ul style="list-style-type: none"><li><input type="checkbox"/> MVLI823</li><li><input type="checkbox"/> MVLI824</li><li><input type="checkbox"/> MVLI834</li><li><input type="checkbox"/> MVLI835</li><li><input type="checkbox"/> MVLI836</li><li><input type="checkbox"/> MVRR904</li><li><input type="checkbox"/> MVRR991</li><li><input type="checkbox"/> MVSD402</li><li><input type="checkbox"/> MVSD405</li></ul>  |
| Corporate Action Event     | <p>Enter the identification assigned by the account servicer to unambiguously identify a corporate action event.</p> <p>Required format is: max. 16 characters (SWIFT-x-red)</p> <p>References for error messages [ ▶ 1014]:</p> <ul style="list-style-type: none"><li><input type="checkbox"/> MVSQ607</li><li><input type="checkbox"/> MVSQ611</li></ul>  |
| Priority                   | <p>Select the level of priority assigned to the instruction from the possible values:</p> <ul style="list-style-type: none"><li><input type="checkbox"/> Empty (default value)</li><li><input type="checkbox"/> Normal</li><li><input type="checkbox"/> High</li><li><input type="checkbox"/> Reserved</li></ul> <p>Reference for error message [ ▶ 1014]:</p> <ul style="list-style-type: none"><li><input type="checkbox"/> MVSP210</li></ul>   |
| Securities Account Number* | <p>Select the technical identification of the account to or from which a securities entry is made.</p> <p>Required format is: max. 35 characters (SWIFT-x)</p> <p>References for error messages [ ▶ 1014]:</p> <ul style="list-style-type: none"><li><input type="checkbox"/> MVCP044</li><li><input type="checkbox"/> MCV004</li><li><input type="checkbox"/> MCV124</li><li><input type="checkbox"/> MCV284</li><li><input type="checkbox"/> MCV285</li><li><input type="checkbox"/> MCV290</li></ul> |

| Intra-Position Movement      |  |
|------------------------------|--|
|                              | <input type="checkbox"/> MRRR922   |
| ISIN*                        | Select the ISIN of the security from the drop-down menu.<br>References for error messages [ ▶ 1014]:<br><input type="checkbox"/> MVCV206<br><input type="checkbox"/> MVCV302<br><input type="checkbox"/> MVCV304<br><input type="checkbox"/> MVIC306<br><input type="checkbox"/> MVIC310<br><input type="checkbox"/> MVIC312<br><input type="checkbox"/> MVIC314<br><input type="checkbox"/> MRRR923<br><input type="checkbox"/> MVSQ603<br><input type="checkbox"/> MVSQ605<br><input type="checkbox"/> MVSQ607   |
| Securities Short Name        | Shows the description of the selected ISIN.  |
| Securities Account Owner BIC | Enter the BIC of the securities account owner.<br>Required format is: max. 11 characters (SWIFT-x)<br>Reference for error message [ ▶ 1014]:<br><input type="checkbox"/> MVCV285   |
| Quantity                     | Enter the quantity stated in the settlement restriction on securities.<br>Required format is:<br>For settlement type = Unit, max. 15 digit(s) incl. decimal point (thereof max. 14 decimal places)<br>For settlement type = Face Amount, max. 15 digit(s) incl. decimal point (thereof max. 5 decimal places)<br>This field will be displayed as soon as you select an ISIN.<br>References for error messages [ ▶ 1014]:<br><input type="checkbox"/> MVCV608<br><input type="checkbox"/> MVSQ603<br><input type="checkbox"/> MVSQ605<br><input type="checkbox"/> MVSQ607 |

| Intra-Position Movement          |   |
|----------------------------------|---|
|                                  | <input type="checkbox"/> MVSQ613  |
| Settlement Type                  | <p>Shows the type of settlement foreseen for the securities from the possible values:</p> <ul style="list-style-type: none"><li><input type="checkbox"/> Unit</li><li><input type="checkbox"/> Face Amount</li></ul> <p>Reference for error message [ ▶ 1014]:</p> <ul style="list-style-type: none"><li><input type="checkbox"/> MVSQ613</li></ul>   |
| Restriction Type - Balance from* | <p>You can choose to either enter the 'Restriction Type -Balance from' or to select it from the suggested items in the drop-down menu.</p> <p>References for error messages [ ▶ 1014]:</p> <ul style="list-style-type: none"><li><input type="checkbox"/> MVRR995</li><li><input type="checkbox"/> MVRR902</li><li><input type="checkbox"/> MVRR904</li><li><input type="checkbox"/> MVRR907</li><li><input type="checkbox"/> MVRR908</li><li><input type="checkbox"/> MVRR909</li><li><input type="checkbox"/> MVRR915</li><li><input type="checkbox"/> MVRR921</li><li><input type="checkbox"/> MVRR954</li><li><input type="checkbox"/> MVRR970</li><li><input type="checkbox"/> MVRR971</li><li><input type="checkbox"/> MVRR979</li><li><input type="checkbox"/> MVRR980</li><li><input type="checkbox"/> MVRR981</li><li><input type="checkbox"/> MVCP097</li></ul> <p>All the possible values stored in SD and available according the privileges will be shown.</p> |
| Restriction Type - Balance to*   | <p>You can choose to either enter the 'Restriction Type -Balance to' or to select it from the suggested items in the drop-down menu.</p> <p>References for error messages [ ▶ 1014]:</p> <ul style="list-style-type: none"><li><input type="checkbox"/> MVRR907</li></ul>   |

| Intra-Position Movement |   |
|-------------------------|---|
|                         | <ul style="list-style-type: none"> <li><input type="checkbox"/> MVRR908</li> <li><input type="checkbox"/> MVRR909</li> <li><input type="checkbox"/> MVRR914</li> <li><input type="checkbox"/> MVRR921</li> <li><input type="checkbox"/> MVRR970</li> <li><input type="checkbox"/> MVRR971</li> <li><input type="checkbox"/> MVRR979</li> <li><input type="checkbox"/> MVRR980</li> <li><input type="checkbox"/> MVRR981</li> <li><input type="checkbox"/> MVRR990</li> <li><input type="checkbox"/> MVRR991</li> </ul> <p>All the possible values stored in SD and available according the privileges will be shown.</p>                          |
| Restriction Reference   | <p>Enter the restriction reference applying on securities.<br/>Required format is: max. 16 characters (SWIFT-x-red)<br/>References for error messages [ ▶ 1014]:</p> <ul style="list-style-type: none"> <li><input type="checkbox"/> MVRR919</li> <li><input type="checkbox"/> MVRR921</li> <li><input type="checkbox"/> MVRR922</li> <li><input type="checkbox"/> MVRR923</li> <li><input type="checkbox"/> MVRR954</li> <li><input type="checkbox"/> MVRR970</li> <li><input type="checkbox"/> MVRR971</li> <li><input type="checkbox"/> MVRR980</li> <li><input type="checkbox"/> MVRR981</li> <li><input type="checkbox"/> MVRR982</li> </ul> |
| Link                    |   |
| Link Type               | <p>Select a link processing position from the possible values:</p> <ul style="list-style-type: none"> <li><input type="checkbox"/> After (default value)</li> <li><input type="checkbox"/> Before</li> <li><input type="checkbox"/> With</li> <li><input type="checkbox"/> Info</li> </ul>  |

| Intra-Position Movement |  |
|-------------------------|--|
|                         | <p>References for error messages [ ▶ 1014]:</p> <ul style="list-style-type: none"> <li><input type="checkbox"/> MVLI805</li> <li><input type="checkbox"/> MVLI806</li> <li><input type="checkbox"/> MVLI807</li> <li><input type="checkbox"/> MVLI819</li> <li><input type="checkbox"/> MVLI820</li> <li><input type="checkbox"/> MVLI821</li> <li><input type="checkbox"/> MVLI822</li> <li><input type="checkbox"/> MVLI823</li> <li><input type="checkbox"/> MVLI824</li> <li><input type="checkbox"/> MVLI834</li> <li><input type="checkbox"/> MVLI835</li> <li><input type="checkbox"/> MVLI836</li> <li><input type="checkbox"/> MVLI852</li> <li><input type="checkbox"/> MVLI858</li> <li><input type="checkbox"/> MVLI861</li> <li><input type="checkbox"/> MVLI864</li> <li><input type="checkbox"/> MVLI866</li> <li><input type="checkbox"/> MVLI873</li> <li><input type="checkbox"/> MVLI876</li> <li><input type="checkbox"/> MVCP016</li> <li><input type="checkbox"/> MVLI855</li> </ul> <p>This field is also available as a show field for existing records.</p> |
| Reference Type          | <p>Select the reference type of the instruction to be linked/unlinked to from the possible values:</p> <ul style="list-style-type: none"> <li><input type="checkbox"/> Account Owner Settlement Instruction Reference</li> <li><input type="checkbox"/> Account Owner Settlement Instruction Reference</li> <li><input type="checkbox"/> Account Owner Intra Balance Movement Reference</li> <li><input type="checkbox"/> Account Owner Intra Position Movement Reference</li> <li><input type="checkbox"/> Account Servicer Reference</li> <li><input type="checkbox"/> Third Party reference</li> </ul>  |

| Intra-Position Movement         |  |
|---------------------------------|--|
|                                 | <input type="checkbox"/> T2S reference<br>Required format is: max. 35 characters (SWIFT-x)<br>Reference for error message [ ▶ 1014]:<br><input type="checkbox"/> MVCP099<br>This field is also available as a show field for existing records.   |
| Reference                       | Enter the identification of the instruction to be linked/unlinked to. Required format is: max. 16 characters (SWIFT-x-red)<br>References for error messages [ ▶ 1014]:<br><input type="checkbox"/> MVCP016<br><input type="checkbox"/> MVCP099<br><input type="checkbox"/> MVLI873<br><input type="checkbox"/> MVLI869<br>This field is also available as a show field for existing records. |
| Reference Owner                 | Enter the BIC of the instructing party of the instruction to be linked/unlinked to<br>Required format is: max. 11 characters (SWIFT-x)<br>This field is also available as a show field for existing records.   |
| Options                         | Information on functions (icons) can be found in Common Buttons and Icons [ ▶ 42].   |
| List                            |  |
| Pool Instruction Identification | Enter the collective reference identifying a set of messages.<br>Required format is: max. 16 characters (SWIFT-x-red)<br>References for error messages [ ▶ 1014]:<br><input type="checkbox"/> MVCP016<br><input type="checkbox"/> MVLI836<br><input type="checkbox"/> MVLI846<br><input type="checkbox"/> MVLI848<br><input type="checkbox"/> MVLI868<br><input type="checkbox"/> MVLI876    |

| Intra-Position Movement  |  |
|--------------------------|--|
| Pool Instruction Counter | <p>Enter the pool identification.</p> <p>Required format is: Integer</p> <p>Reference for error message [ ▶ 1014]:</p> <ul style="list-style-type: none"><li><input type="checkbox"/> MVL1844</li></ul> <p>This field becomes mandatory when the 'Pool Instruction Identification' is filled in.</p> |
| Pool Reference Owner BIC | <p>Enter the BIC of the owner of the Pool Instruction Reference.</p> <p>The field 'Pool Reference Owner BIC' becomes mandatory when the field 'Pool Instruction Identification' is filled in.</p>  |

## Buttons

| Buttons |   |
|---------|---|
| Submit  | <p>This function enables you to create a new intra-position movement instruction. Upon clicking on the <i>submit</i> button you will be asked to enter your PIN for digital signature purposes (NRO). With the entry of the PIN, T2S attaches a digital signature to the instruction entered by the T2S actor.</p> <p>Next screen:</p> <ul style="list-style-type: none"><li><input type="checkbox"/> <i>Intra-position movements – search/list</i> screen [ ▶ 136]</li></ul> <p>References for error messages [ ▶ 1014]:</p> <ul style="list-style-type: none"><li><input type="checkbox"/> MVCP015</li><li><input type="checkbox"/> MVCP016</li><li><input type="checkbox"/> MVCP044</li><li><input type="checkbox"/> MVCP097</li><li><input type="checkbox"/> MVCP099</li><li><input type="checkbox"/> MVCP120</li><li><input type="checkbox"/> MCV004</li><li><input type="checkbox"/> MCV110</li><li><input type="checkbox"/> MCV124</li><li><input type="checkbox"/> MCV206</li><li><input type="checkbox"/> MCV230</li><li><input type="checkbox"/> MCV284</li><li><input type="checkbox"/> MCV285</li></ul> |



- MVCV290
- MVCV302
- MVCV304
- MVCV608
- MVDC003
- MVDC005
- MVDC007
- MVDC015
- MVDC017
- MVDC019
- MVDC022
- MVDC023
- MVDC025
- MVIC306
- MVIC310
- MVIC312
- MVIC314
- MVLI805
- MVLI806
- MVLI807
- MVLI819
- MVLI820
- MVLI821
- MVLI822
- MVLI823
- MVLI824
- MVLI834
- MVLI835
- MVLI836
- MVLI844
- MVLI846
- MVLI848

- MVLI852
- MVLI855
- MVLI858
- MVLI861
- MVLI864
- MVLI866
- MVLI868
- MVLI869
- MVLI873
- MVLI876
- MVRR902
- MVRR904
- MVRR907
- MVRR908
- MVRR909
- MVRR914
- MVRR915
- MVRR919
- MVRR921
- MVRR922
- MVRR923
- MVRR954
- MVRR970
- MVRR971
- MVRR979
- MVRR980
- MVRR981
- MVRR982
- MVRR990
- MVRR991
- MVRR995
- MVSD402

|        |  |
|--------|--|
|        | <input type="checkbox"/> MVSD405<br><input type="checkbox"/> MVSP210<br><input type="checkbox"/> MVSQ603<br><input type="checkbox"/> MVSQ605<br><input type="checkbox"/> MVSQ607<br><input type="checkbox"/> MVSQ611<br><input type="checkbox"/> MVSQ613<br><input type="checkbox"/> MVSR705<br><input type="checkbox"/> MVSR706<br><input type="checkbox"/> MVSR708 |
| Cancel | <p>This function enables you to cancel the process and return to the previous screen.</p> <p>Next screen:</p> <input type="checkbox"/> <i>Intra-position movements – search/list screen</i> [▶ 136]  |
| Reset  | <p>This function enables you to set all fields to default value and blanks out all optional fields.</p> <p>Next screen:</p> <input type="checkbox"/> <i>Intra-position movement - new screen</i>   |

## 2.2.2.14 Maintenance Securities Instructions - Search/List Screen

**Context of Usage**

This screen contains a number of search fields. By inputting the relevant data, you can search for maintenance securities instructions. The search results will be displayed in a list. After selecting an entry, you can proceed further by clicking on the buttons below.

This screen is not relevant for CB users.

**Screen Access**

Securities >> Settlement >> Maintenance Securities Instructions >> *Maintenance securities instructions – search/list screen*

**Privileges**

To use this screen, you need the following privileges [▶ 889]:

- Amendment instruction query for intra-position movements and settlement instructions
- Maintenance for intra-position movements and settlement instructions query
- Cancellation instruction query for intra-position movements and settlement instructions

**References User Instructions Part**

This screen is part of the following business scenarios:

- View amendment instruction for a settlement instruction details [▶ 711]
- View amendment instruction for a settlement restriction on securities details [▶ 764]
- View cancellation instruction for a settlement instruction details [▶ 729]
- View cancellation instruction for a settlement restriction on securities details [▶ 775]
- View hold/release instruction details [▶ 725]

**Business Functionality Document**

This screen corresponds to the following business function:

- Query instruction (T2S.GUI.SESE.INX.0010)
- Display instruction list (T2S.GUI.SESE.INX.0020)

**Screenshot**

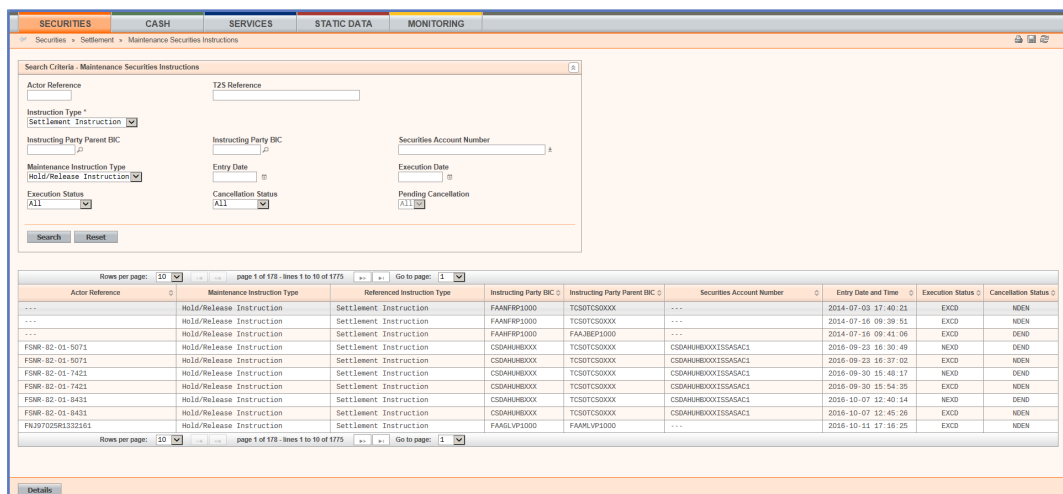

Illustration 53: Maintenance securities instructions - search/list screen

**Field Description**

| Maintenance Securities Instructions – Search Criteria |   |
|---|---|
| Actor Reference                                       | Enter the identification assigned by the T2S actor.<br>Required format is: max. 16 characters (SWIFT-x)   |
| T2S Reference   | Enter the identification of the reference assigned to the referenced instruction by T2S.<br>Required format is: max. 16 characters (SWIFT-x)  |
| Instruction Type                                      | Select the instruction type of the maintenance securities instruction from the possible values: <ul style="list-style-type: none"> <li><input type="checkbox"/> Settlement Instruction (default value)</li> <li><input type="checkbox"/> Intra-Position Movement</li> <li><input type="checkbox"/> All</li> </ul> |

| Maintenance Securities Instructions – Search Criteria |   |
|---|---|
| Instructing Party BIC                                 | <p>You can choose to either enter the BIC of the instructing party or to select it from the suggested items in the drop-down menu.</p> <p>Required format is: max. 11 characters (SWIFT-x)</p> <p>References for error messages [ ▶ 1042]:</p> <ul style="list-style-type: none"> <li><input type="checkbox"/> QMPC032</li> <li><input type="checkbox"/> QMPC084</li> </ul>   |
| Instructing Party Parent BIC                          | <p>You can choose to either enter the parent BIC of the instructing party or to select it from the suggested items in the drop-down menu.</p> <p>Required format is: max. 11 characters (SWIFT-x)</p> <p>References for error messages [ ▶ 1042]:</p> <ul style="list-style-type: none"> <li><input type="checkbox"/> QMPC048</li> <li><input type="checkbox"/> QMPC084</li> </ul>  |
| Securities Account Number                             | <p>You can choose to either enter the 'Securities Account Number' or to select it from the suggested items in the drop-down menu.</p> <p>Reference for error message [ ▶ 1042]:</p> <ul style="list-style-type: none"> <li><input type="checkbox"/> QMPC030</li> </ul>  |
| Maintenance Instruction Type*                         | <p>Select the type of the maintenance instruction from the possible values:</p> <ul style="list-style-type: none"> <li><input type="checkbox"/> Cancellation Instruction</li> <li><input type="checkbox"/> Amendment Instruction</li> <li><input type="checkbox"/> Hold/release Instruction (default value)</li> </ul> <p>The value 'Hold/Release Instruction' cannot be selected if the 'Instruction Type' is 'Intra-Position Movement'.</p> |
| Entry Date  | <p>Enter the date when the maintenance instruction was created in T2S or use the <i>calendar</i> icon.</p> <p>Required format is: YYYY-MM-DD</p> <p>Reference for error message [ ▶ 1042]:</p> <ul style="list-style-type: none"> <li><input type="checkbox"/> QMPC073</li> </ul>   |
| Execution Date  | <p>Enter the business date when the maintenance instruction has been executed or use the <i>calendar</i> icon.</p> <p>Required format is: YYYY-MM-DD</p>  |

| Maintenance Securities Instructions – Search Criteria   |  |
|---|--|
|   | References for error messages [ ▶ 1042]:<br><input type="checkbox"/> QMPC016<br><input type="checkbox"/> QMPC073   |
| Execution Status  | Select the execution status of the maintenance instruction from the possible values:<br><input type="checkbox"/> All (default value)<br><input type="checkbox"/> Not Executed<br><input type="checkbox"/> Executed                                 |
| Cancellation Status                                     | Select the cancellation status of the maintenance instruction from the possible values:<br><input type="checkbox"/> All (default value)<br><input type="checkbox"/> Denied<br><input type="checkbox"/> Not Denied                                  |
| Pending Cancellation                                    | Select the pending cancellation status of the maintenance instruction (only for cancellation instruction) from the possible values:<br><input type="checkbox"/> All (default value)<br><input type="checkbox"/> Yes<br><input type="checkbox"/> No |
| Maintenance Securities Instructions - List <sup>3</sup> |  |
| Actor Reference   | Shows the identification assigned by the T2S Actor.  |
| Maintenance Instruction Type                            | Shows the type of the maintenance instruction from the possible values:<br><input type="checkbox"/> Amendment instruction<br><input type="checkbox"/> Cancellation instruction<br><input type="checkbox"/> Hold/release instruction                |
| Referenced Instruction Type                             | Shows the type of the referenced instruction from possible values:   |

3 The line counter can state a higher number than the provided actual lines (i.e. query results) because the "orphan" registers are only removed from the query results and not from counter.

Orphan results are resulting from:

- Maintenance instructions sent in a moment in which its underlying instruction was already in a final status (and hence the maintenance could no longer be executed). These maintenance instructions are purged after 90 days and would be shown in the query results until then.
- Maintenance instructions in status AWAP, whose underlying settlement instruction is in its final status or has even been purged. In this case, the maintenance instructions cannot be purged (as they are awaiting for user action) and will be shown permanently, unless the user rejects them and it can be, after 90 days, purged.

| Maintenance Securities Instructions – Search Criteria |   |
|---|---|
|   | <input type="checkbox"/> Settlement instruction<br><input type="checkbox"/> Intra-position movement   |
| Instructing Party BIC                                 | Shows the BIC of the instructing party of the referenced instruction.   |
| Instructing Party Parent BIC                          | Shows the parent BIC of the instructing party of the referenced instruction.  |
| Securities Account Number                             | Shows the number of the securities account.   |
| Entry Date and Time                                   | Shows the date and time when the maintenance instruction has been created.<br><br>Displayed format is: YYYY-MM-DD hh:mm:ss  |
| Execution Status                                      | Shows the execution status of the maintenance instruction from the possible values:<br><br><input type="checkbox"/> Not executed<br><input type="checkbox"/> Executed |
| Cancellation Status                                   | Shows the cancellation status of the maintenance instruction from the possible values:<br><br><input type="checkbox"/> Not denied<br><input type="checkbox"/> Denied  |

## Buttons

| Buttons |  |
|---------|--|
| Search  | <p>This function enables you to start a search according to the criteria entered. The results are displayed in a list on the next screen.</p> <p>If the search retrieves a single record, the <i>details</i> screen is displayed directly.</p> <p>Next screens:</p> <ul style="list-style-type: none"> <li><input type="checkbox"/> <i>Maintenance securities instruction – search/list</i> screen</li> <li><input type="checkbox"/> <i>Amendment securities instruction – details</i> screen [ ▶ 97]</li> <li><input type="checkbox"/> <i>Cancellation securities instruction – details</i> screen [ ▶ 112]</li> <li><input type="checkbox"/> <i>Hold/release instruction – details</i> screen [ ▶ 121]</li> </ul> <p>References for error messages [ ▶ 1042]:</p> <ul style="list-style-type: none"> <li><input type="checkbox"/> QMPC016</li> </ul> |

|         |   |
|---------|---|
|         | <input type="checkbox"/> QMPC030<br><input type="checkbox"/> QMPC032<br><input type="checkbox"/> QMPC048<br><input type="checkbox"/> QMPC073<br><input type="checkbox"/> QMPC084  |
| Reset   | <p>This function enables you to set default search criteria and blanks out all optional criteria.</p> <p>Next screen:</p> <input type="checkbox"/> <i>Maintenance securities instruction – search/list screen</i>   |
| Details | <p>This function enables you to display the details of the selected maintenance instruction.</p> <p>Next screens:</p> <input type="checkbox"/> <i>Amendment securities instruction – details screen</i> [▶ 97]<br><input type="checkbox"/> <i>Cancellation securities instruction – details screen</i> [▶ 112]<br><input type="checkbox"/> <i>Hold/release instruction – details screen</i> [▶ 121] |

## 2.2.2.15 Securities Positions - Search/List Screen

### Context of Usage

This screen contains a number of search fields. By inputting the relevant data, you can search for securities positions. This screen retrieves information for any T2S securities account owner, i.e. a party which is a CSD, a CB (as CSD participant) or a settlement bank. The search results will be displayed in a list, which is sorted by the value of the 'Securities Account Number' column in ascending order (default setting). After selecting an entry, you can proceed further by clicking on the buttons below.

During the Start of Day, when the CRDM data is being replicated in the Settlement domain, only the securities positions data available at the End-of-Day of the previous business day is displayed at the screen. The securities positions data for the new business day is available as of the end of the CRDM data replication.

During night-time, the securities positions can only be displayed in-between night-time settlement sequences.

### Screen Access

- Securities >> Securities Account >> Securities Positions
- Securities >> Settlement >> Securities Positions
- Monitoring >> Monitoring >> Securities Positions



**Privileges** To use this screen, you need the following privilege [▶ 897]:

- Securities account position query

**References** **User Instructions Part**

This screen is part of the following business scenarios:

- View current securities positions and related postings [▶ 681]
- View current securities positions and related restrictions [▶ 682]
- View historic securities positions for a specific period [▶ 684]
- View historic securities positions for a specific date [▶ 683]

**Business Functionality Document**

This screen corresponds to the following business function:

- Display securities account positions (T2S.GUI.SESE.POS.0020)

**Screenshot**

| Securities Account Number | Security     |                       | Restriction Type | Date and Time       | Securities Position |      |                |
|---------------------------|--------------|-----------------------|------------------|---------------------|---------------------|------|----------------|
|                           | ISIN         | Securities Short Name |                  |                     | U/F                 | Cur. | Total Quantity |
| CSDAHUHBXXXISSASAC1       | ES0000010027 | SCS/FRI               | ALL              | 2017-01-17 09:50:10 | U                   |      | -50,000        |
| CSDAHUHBXXXISSASAC1       | ES0000010126 | SCS/FRI               | ALL              | 2017-01-17 09:50:10 | U                   |      | -50,000        |
| CSDAHUHBXXXISSASAC1       | ES0000010134 | SCS/FRI               | ALL              | 2017-01-17 09:50:10 | U                   |      | -50,000        |
| CSDAHUHBXXXISSASAC1       | ES0000010142 | SCS/FRI               | ALL              | 2017-01-17 09:50:10 | U                   |      | -100,000       |
| CSDAHUHBXXXISSASAC1       | ES0000010175 | SCS/FRI               | ALL              | 2017-01-17 09:50:10 | U                   |      | -100,000       |
| CSDAHUHBXXXISSASAC1       | ES0000010183 | SCS/FRI               | ALL              | 2017-01-17 09:50:10 | U                   |      | -200,000       |
| CSDAHUHBXXXISSASAC1       | HUNEURPAD020 | HUNEUR/PA0020         | ALL              | 2017-01-17 09:50:10 | F                   | EUR  | -2,775,750     |
| CSDAHUHBXXXISSASAC1       | HUNEURPAD038 | HLT/PD                | ALL              | 2017-01-17 09:50:10 | U                   |      | -970           |
| CSDAHUHBXXXISSASAC1       | HUNEURPAD061 | HU3/PD                | ALL              | 2017-01-17 09:50:10 | F                   | EUR  | -6,000         |
| CSDAHUHBXXXISSASAC1       | HUUEURNA0007 | HUUEURNA/0007         | ALL              | 2017-01-17 09:50:10 | U                   |      | -50,000        |

Illustration 54: Securities positions – search/list screen

**Field Description**

| Securities Positions – Search Criteria |  |
|--|--|
| Party BIC*                             | <p>Select the BIC of the party owning the securities positions you want to retrieve from the drop-down menu or search via the <i>magnifier</i> icon.</p> <p>At least Party BIC or ISIN must be provided as search criteria. When opening the screen, this field will be defaulted to the Party BIC of the user’s party.</p> <p>References for error messages: [▶ 1053]</p> |

| Securities Positions – Search Criteria |   |
|--|---|
|  | <input type="checkbox"/> QMPC032<br><input type="checkbox"/> QMPC065  |
| Parent BIC*                            | <p>Select the BIC of the CSD where the above party holds the securities positions you want to retrieve from the drop-down menu.</p> <p>When opening the screen, this field will be defaulted to the Parent BIC of the user's party.</p> <p>References for error messages: [▶ 1053]</p> <input type="checkbox"/> QMPC048<br><input type="checkbox"/> QMPC065 |
| Securities Account Number              | <p>Select the number of the securities account from the drop-down menu.</p> <p>If there is only 1 possible securities account, this field is read-only.</p> <p>References for error messages: [▶ 1053]</p> <input type="checkbox"/> QMPC030<br><input type="checkbox"/> QMPC065   |
| ISIN                                   | <p>Enter the ISIN of the security.</p> <p>Required format is: 12 characters (SWIFT-x), input-sensitive</p> <p>The ISIN must exist in T2S.</p> <p>At least Party BIC or ISIN must be provided as search criteria.</p> <p>Reference for error message: [▶ 1053]</p> <input type="checkbox"/> QMPC018  |
| Country of Issuance - Code             | <p>Select the country where the securities are issued from the drop-down menu.</p>  |
| Restriction Type                       | <p>Select the restriction type if you want to view only the securities positions for one restriction type from the drop-down menu.</p> <p>If you select the value 'All', the sum of all securities positions is displayed in the list.</p> <p>Reference for error message: [▶ 1053]</p> <input type="checkbox"/> QMPC091                                    |

| Securities Positions – Search Criteria   |   |
|--|---|
| Date from  | <p>Enter the date from which you want to view the securities positions or use the <i>calendar</i> icon. The default value is the current business day.</p> <p>Required format is: YYYY-MM-DD</p> <p>The Date from date must be a valid business date earlier than or equal to the current business date and earlier than or equal to the Date to date.</p> <p>References for error messages: [ ▶ 1053]</p> <ul style="list-style-type: none"> <li><input type="checkbox"/> QMPC015</li> <li><input type="checkbox"/> QMPC016</li> </ul> |
| Date to  | <p>Enter the date until which you want to view the securities positions or use the <i>calendar</i> icon. The default value is the date entered in the 'Date from' field.</p> <p>Required format is: YYYY-MM-DD</p> <p>The Date to date must be a valid business date earlier than or equal to the current business date.</p> <p>Reference for error message: [ ▶ 1053]</p> <ul style="list-style-type: none"> <li><input type="checkbox"/> QMPC015</li> </ul>   |
| Nil Securities Position included   | Select whether securities position(s) equal to 0 are included. The default value is 'No (not checked)'.   |
| Multiple Securities Positions (Multiple Securities Accounts / Multiple Securities) |   |
| Securities Account Number  | <p>Shows the number of the securities account of the securities position.</p> <p>References for error messages: [ ▶ 1053]</p> <ul style="list-style-type: none"> <li><input type="checkbox"/> QMPC030</li> <li><input type="checkbox"/> QMPC065</li> </ul>  |
| ISIN   | <p>Show the ISIN of the security.</p> <p>Reference for error message: [ ▶ 1053]</p> <ul style="list-style-type: none"> <li><input type="checkbox"/> QMPC018</li> </ul>  |
| Securities Short Name  | Shows the short name of the security.   |
| Restriction Type   | <p>Shows the restriction type of the securities position.</p> <p>Reference for error message: [ ▶ 1053]</p> <ul style="list-style-type: none"> <li><input type="checkbox"/> QMPC091</li> </ul>  |

| Securities Positions – Search Criteria |   |
|--|---|
| Date and Time                          | Shows the date and time of the last movement of the securities position when positions are retrieved for the current business date and the date of the position when positions are retrieved for a period.<br><br>Displayed format is: YYYY-MM-DD hh:mm:ss:µsµsµsµsµs   |
| Settlement Type                        | Shows the quantity type related to the securities from the possible values:<br><br><input type="checkbox"/> U (for unit)<br><input type="checkbox"/> F (for face amount)  |
| Currency                               | Shows the currency in which the securities were issued.<br><br>This field is only filled if the quantity of the securities position is given as a face amount.  |
| Total Quantity                         | Shows the total quantity of the securities position per securities account and ISIN.<br><br>If the Date to is different from the Date from, the different end of day values of the position for each date of the selected period are shown.<br><br>Provision of '99999...99' in case oversizing occurs in the integer portion. Truncation of decimals in case oversizing occurs in the decimal portion. |

## Buttons

|        |   |
|--------|---|
| Search | <p>This function enables you to start a search according to the criteria entered. The results are displayed in a list on the same screen.</p> <p>If the search retrieves a single record, the <i>details</i> screen is displayed directly.</p> <p>Next screens:</p> <ul style="list-style-type: none"> <li><input type="checkbox"/> <i>Securities positions - search/list</i> screen</li> <li><input type="checkbox"/> <i>Securities position - details</i> screen [▶ 173]</li> </ul> <p>References for error messages: [▶ 1053]</p> <ul style="list-style-type: none"> <li><input type="checkbox"/> QMPC015</li> <li><input type="checkbox"/> QMPC016</li> <li><input type="checkbox"/> QMPC018</li> <li><input type="checkbox"/> QMPC030</li> <li><input type="checkbox"/> QMPC032</li> </ul> |
|--------|---|

|                                |  |
|--------------------------------|--|
|                                | <input type="checkbox"/> QMPC048<br><input type="checkbox"/> QMPC065<br><input type="checkbox"/> QMPC091   |
| Reset                          | <p>This function enables you to set default search criteria and blanks out all optional criteria.</p> <p>Next screen:</p> <input type="checkbox"/> <i>Securities positions - search/list</i> screen                                    |
| Details                        | <p>This function enables you to display the details of the selected securities position.</p> <p>Next screen:</p> <input type="checkbox"/> <i>Securities position – details</i> screen [ ▶ 173]   |
| Create Intra-position movement | <p>This function enables you to create a new restricted securities position for the selected securities account number and ISIN.</p> <p>Next screen:</p> <input type="checkbox"/> <i>Intra-position movement - new</i> screen [ ▶ 150] |

## 2.2.2.16 Securities Position - Details Screen

### Context of Usage

This screen displays detailed information on the securities positions for a T2S securities account owner, i.e. a party which is a CSD, a CB (as CSD participant) or a settlement bank. You can check the data and proceed further by clicking on the buttons below.

During the Start of Day, when the CRDM data is being replicated in the Settlement domain, only the securities positions data available at the End-of-Day of the previous business day is displayed at the screen. The securities positions data for the new business day is available as of the end of the CRDM data replication.

During night-time, the securities positions can only be displayed in-between night-time settlement sequences.

### Screen Access

- Securities >> Securities Account >> Securities Positions >> *Securities positions – search/list* screen >> Click on the *search* and/or *details* button
- Securities >> Settlement >> Securities Positions >> *Securities positions – search/list* screen >> Click on the *search* and/or *details* button
- Monitoring >> Monitoring >> Securities Positions >> *Securities positions – search/list* screen >> Click on the *search* and/or *details* button

- Securities >> Settlement >> Intra-position Movements >> *Intra-position movements with current and historical status – search screen* >> Click on the *search* button >> *Intra-position movements – list screen* >> Click on the *details* button >> *Intra-position movement – details screen* >> Click on the *securities position details* button

**Privileges** No privilege needed to use this screen.

**References** **User Instructions Part**

This screen is part of the following business scenarios:

- View current securities positions and related postings [▶ 681]
- View current securities positions and related restrictions [▶ 682]
- View historic securities positions for a specific period [▶ 684]
- View historic securities positions for a specific date [▶ 683]

**Business Functionality Document**

This screen corresponds to the following business function:

- Display securities account positions (T2S.GUI.SESE.POS.0020)

**Screenshot**

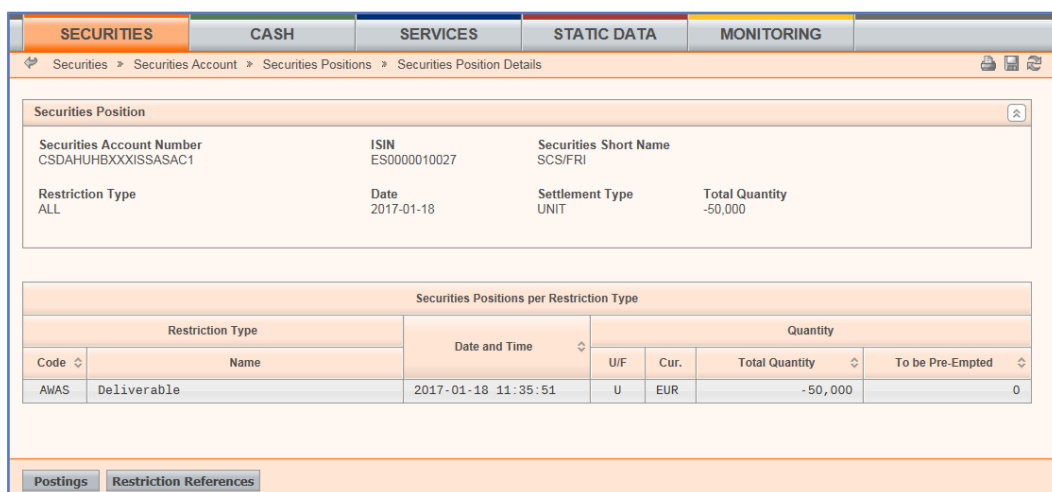

Illustration 55: Securities position – details screen

**Field Description**

| Identification of Securities Positions |  |
|--|--|
| Securities Account Number              | Shows the number of the securities account of the securities position.                                 |
| ISIN                                   | Shows the ISIN of the security.  |
| Securities Short Name                  | Shows the short name of the security.  |
| Restriction Type                       | Shows the restriction type of the securities position.   |
| Date                                   | Shows the date for which you requested the securities position.<br><br>Displayed format is: YYYY-MM-DD |

| Identification of Securities Positions    |  |
|---|--|
| Settlement Type                           | Shows the quantity type related to the securities from the possible values:<br><br><input type="checkbox"/> U (for unit)<br><input type="checkbox"/> F (for face amount)   |
| Currency                                  | Shows the currency in which the securities were issued.<br><br>This field is only filled if the quantity of the security is given as a face amount.  |
| Total Quantity                            | Shows the total quantity of the securities position per securities account and ISIN.<br><br>Provision of '99999...99' in case oversizing occurs in the integer portion. Truncation of decimals in case oversizing occurs in the decimal portion. |
| Securities Positions per Restriction Type |  |
| Restriction Type                          |  |
| Code                                      | Shows the code of the restriction type of the securities position.   |
| Name                                      | Shows the name of the restriction type of the securities position.<br><br>Only the first 35 characters of the restriction type description are displayed here.   |
| Date and Time                             | Shows the date and time of the last movement related to the securities position.<br><br>Displayed format is: YYYY-MM-DD hh:mm:ss:µsµsµsµsµs  |
| Quantity                                  |  |
| Settlement Type                           | Shows the quantity type related to the securities from the possible values:<br><br><input type="checkbox"/> U (for Unit)<br><input type="checkbox"/> F (for Face amount)   |
| Currency                                  | Shows the currency in which the securities were issued.<br><br>This field is only filled if the quantity of the securities position is given as a face amount.   |
| Total Quantity                            | Shows the total quantity of the securities position per restriction type.  |

| Identification of Securities Positions |   |
|--|---|
|  | Provision of '99999...99' in case oversizing occurs in the integer portion. Truncation of decimals in case oversizing occurs in the decimal portion.  |
| To Be Pre-Empted                       | Shows the quantity of the securities position that is to be pre-empted.<br><br>Provision of '99999...99' in case oversizing occurs in the integer portion. Truncation of decimals in case oversizing occurs in the decimal portion. |

**Buttons**

| Buttons                 |   |
|-------------------------|---|
| Postings                | This function displays the securities postings for the selected securities position.<br><br>Next screen:<br><input type="checkbox"/> <a href="#">Securities postings - search/list screen [ 81]</a>                         |
| Restrictions References | This function displays the details per restriction reference for the selected securities position.<br><br>Next screen:<br><input type="checkbox"/> <a href="#">Securities restriction detail - search/list screen [ 85]</a> |

## 2.2.2.17 Settlement Instructions - Search/List Screen

**Context of Usage**

This screen contains a number of search fields. By inputting the relevant data, you can search for settlement instructions. The search results will be displayed in a list.

After selecting an entry, you can proceed further by clicking on the buttons below.

This screen is not relevant for CB users.

**Screen Access**

[Securities >> Settlement >> Settlement Instructions](#)

**Privileges**

To use this screen, you need the following privileges [ [903](#)]:

Settlement instruction query

**References****User Instructions Part**

This screen is part of the following business scenarios:

- [Add a link for a settlement instruction \[ 703\]](#)
- [Amend the partial settlement indicator for a settlement instruction \[ 706\]](#)
- [Amend the priority for a settlement instruction \[ 707\]](#)
- [Cancel a settlement instruction \[ 727\]](#)



- Copy a settlement instruction [[▶ 690](#)]
- Enter a settlement instruction [[▶ 686](#)]
- Put a settlement instruction on CSD hold [[▶ 715](#)]
- Put a settlement instruction on party hold [[▶ 713](#)]
- Release a settlement instruction from CoSD hold [[▶ 722](#)]
- Release a settlement instruction from CSD hold [[▶ 720](#)]
- Release a settlement instruction from CSD validation hold [[▶ 724](#)]
- Release a settlement instruction from party hold [[▶ 717](#)]
- Partially release a settlement instruction from party hold [[▶ 718](#)]
- Remove a link for a settlement instruction [[▶ 709](#)]
- View Alleged Cancellation Instructions [[▶ 730](#)]
- View settlement instruction details [[▶ 701](#)]

#### **Business Functionality Document**

This screen corresponds to the following business functions:

- Query instruction (T2S.GUI.SESE.INX.0010)
- Display instruction list (T2S.GUI.SESE.INX.0020)

Screenshot

The screenshot displays the 'Settlement Instructions - Search/List' screen. It features a navigation bar with tabs for SECURITIES, CASH, SERVICES, and MONITORING. The main content area is titled 'Search Criteria - Settlement Instructions' and is organized into several sections:

- General Criteria:** Includes fields for Actor Reference, T2S Reference, Account Owner Reference, Account Servicer Reference, Third Party Reference, T2S Matching Reference, Instructing Party Parent BIC, Instructing Party BIC, ISIN, Securities Account, Account Owner, Dedicated Cash Account, Pool Reference, Common Reference, and Corporate Action Event.
- Multiple Value Criteria:** Includes Securities Movement Type Code, Payment Type Code, Securities Transaction Type, CumEx Indicator, Settlement Transaction Condition Indicator, Credit Debit Code, Settlement Currency, and Country of Issuance - Code.
- Other Criteria:** Includes Priority, Issuer CSD, Delivering CSD BIC, Receiving CSD BIC, Delivering CSD Participant, Receiving CSD Participant, Delivering CSD Participant Processing Reference, Receiving CSD Participant Processing Reference, Delivering CSD Client of the Participant BIC, Partial Settlement Indicator, and CoSD Flag.
- Range Criteria:** Includes Trade Date (from/to), Intended Settlement Date (from/to), Actual Settlement Date (from/to), Quantity or nominal of securities (from/to), Settlement Type, and Settlement Cash Amount (from/to).
- Status Criteria:** Includes ISO Settlement Status, Settlement Status (from/to), Matching Status (from/to), Cancellation Status (from/to), CSD Hold Status (from/to), Party Hold Status (from/to), CSD Validation Hold Status (from/to), CoSD Hold Status (from/to), and Approval Status (from/to).

At the bottom, there are 'Search' and 'Reset' buttons, a pagination control showing 'page 1 of 1 - lines 1 to 2 of 2', and a table with columns: Actor Reference, Instructing Party BIC, Instructing Party Parent BIC, Securities Account Number, and ISIN. The table contains two rows of data.

Illustration 56: Settlement instructions - search/list screen

Field Description

| Settlement Instructions – Search Criteria |   |
|---|---|
| General Criteria                          |   |
| Actor Reference                           | Enter the identification assigned by the T2S actor.<br>The settlement instruction can be identified by the T2S reference or the combination of the actor reference and the instructing party BIC. |

| Settlement Instructions – Search Criteria |   |
|---|---|
|   | Required format is: max. 16 characters (SWIFT-x)  |
| T2S Reference                             | Enter the instruction identification code assigned by T2S.<br>Required format is: max. 16 characters (SWIFT-x)  |
| Securities Account Owner Reference        | Enter the reference assigned by the T2S delivering/receiving party to the instruction.<br>Required format is: max. 16 characters (SWIFT-x)  |
| Securities Account Servicer Reference     | Enter the reference of an instruction as assigned by the CSD.<br>Required format is: max. 16 characters (SWIFT-x)   |
| Third Party Reference                     | Enter the reference of an instruction as assigned by the third party.<br>Required format is: max. 16 characters (SWIFT-x)   |
| T2S Matching Reference                    | Enter the common reference assigned by T2S to all the settlement instructions comprising a transaction.<br>Required format is: max. 16 characters (SWIFT-x)   |
| Instructing Party BIC                     | You can choose to either enter the 'Instructing Party BIC' or to select it from the suggested items in the drop-down menu.<br>Required format is: max. 11 characters (SWIFT-x)<br>Reference for error message [ ▶ 1115]:<br><input type="checkbox"/> QMPC032        |
| Instructing Party Parent BIC              | You can choose to either enter the 'Instructing Party Parent BIC' or to select it from the suggested items in the drop-down menu.<br>Required format is: max. 11 characters (SWIFT-x)<br>Reference for error message [ ▶ 1115]:<br><input type="checkbox"/> QMPC048 |
| ISIN                                      | Select the ISIN of the settlement instruction from the drop-down menu.<br>Required format is: 12 characters (SWIFT-x)<br>Reference for error message [ ▶ 1115]:<br><input type="checkbox"/> QMPC018   |
| Securities Account Number                 | You can choose to either enter the 'Securities Account Number' or to select it from the suggested items in the drop-down menu.  |

| Settlement Instructions – Search Criteria |  |
|---|--|
|   | <p>In order to query external CSD settlement instructions the selection criterion 'Securities Account Number' must not be filled in.</p> <p>Required format is: max. 35 characters (SWIFT-x)</p> <p>Reference for error message [ ▶ 1115]:</p> <ul style="list-style-type: none"> <li><input type="checkbox"/> QMPC030</li> </ul>      |
| Securities Account Owner BIC              | <p>You can choose to either enter the 'Securities Account Owner BIC' or to select it from the suggested items in the drop-down menu.</p> <p>Required format is: max. 11 characters (SWIFT-x)</p>   |
| T2S Dedicated Cash Account Number         | <p>You can choose to either enter the 'T2S Dedicated Cash Account Number' or to select it from the suggested items in the drop-down menu.</p> <p>Required format is: max. 34 characters (SWIFT-x)</p> <p>Reference for error message [ ▶ 1115]:</p> <ul style="list-style-type: none"> <li><input type="checkbox"/> QMPC031</li> </ul> |
| Pool Reference                            | <p>Enter the reference of the pool of the settlement instruction.</p> <p>Required format is: max. 35 characters (SWIFT-x)</p>  |
| Common Reference                          | <p>Enter the common reference of the settlement instruction.</p> <p>Required format is: max. 35 characters (SWIFT-x)</p>   |
| Corporate Action Event                    | <p>Enter the reference of the corporate action event.</p> <p>Required format is: max. 35 characters (SWIFT-x)</p>  |
| <b>Multiple Value Criteria</b>            |  |
| Securities Movement Type                  | <p>Select the securities movement type code from the possible values:</p> <ul style="list-style-type: none"> <li><input type="checkbox"/> All (default value)</li> <li><input type="checkbox"/> Delivery</li> <li><input type="checkbox"/> Receive</li> </ul>  |
| Payment Type Code                         | <p>Select the payment type code from the possible values:</p> <ul style="list-style-type: none"> <li><input type="checkbox"/> All (default value)</li> <li><input type="checkbox"/> Against payment settlement</li> <li><input type="checkbox"/> Free of payment</li> </ul>  |

| Settlement Instructions – Search Criteria |  |
|---|--|
| Securities Transaction Type               | <p>Enter or select the securities transaction type expressed as an ISO 20022 code from the possible values:</p> <ul style="list-style-type: none"><li><input type="checkbox"/> All (default value)</li><li><input type="checkbox"/> AUTO (for auto-collateralisation)</li><li><input type="checkbox"/> BYIY (for buy-in)</li><li><input type="checkbox"/> BSBK (for buy sell back)</li><li><input type="checkbox"/> CLAI (for market claim)</li><li><input type="checkbox"/> CNCB (for central bank collateral operation)</li><li><input type="checkbox"/> COLI (for collateral in)</li><li><input type="checkbox"/> COLO (for collateral out)</li><li><input type="checkbox"/> CONV (for depository receipt conversion)</li><li><input type="checkbox"/> CORP (for corporate action)</li><li><input type="checkbox"/> ETFT (for exchange traded funds)</li><li><input type="checkbox"/> FCTA (for factor update)</li><li><input type="checkbox"/> INSP (for move of stock)</li><li><input type="checkbox"/> ISSU (for depository receipt issue)</li><li><input type="checkbox"/> MKDW (for mark down)</li><li><input type="checkbox"/> MKUP (for mark up)</li><li><input type="checkbox"/> NETT (for netting)</li><li><input type="checkbox"/> NSYN (for non syndicated)</li><li><input type="checkbox"/> OWNE (for external account transfer)</li><li><input type="checkbox"/> OWNI (for internal account transfer)</li><li><input type="checkbox"/> PAIR (for pair off)</li><li><input type="checkbox"/> PLAC (for placement)</li><li><input type="checkbox"/> PORT (for portfolio move)</li><li><input type="checkbox"/> REAL (for realignment)</li><li><input type="checkbox"/> REDI (for withdrawal)</li><li><input type="checkbox"/> REDM (for redemption)</li><li><input type="checkbox"/> RELE (for depository receipt release cancellation)</li><li><input type="checkbox"/> REPU (for repo)</li><li><input type="checkbox"/> RODE (for return delivery without matching)</li><li><input type="checkbox"/> RVPO (for reverse repurchase agreement)</li></ul> |

| Settlement Instructions – Search Criteria              |   |
|--|---|
|  | <ul style="list-style-type: none"><li><input type="checkbox"/> SBBK (for sell buy back)</li><li><input type="checkbox"/> SBRE (for borrowing reallocation)</li><li><input type="checkbox"/> SECB (for securities borrowing)</li><li><input type="checkbox"/> SECL (for securities lending)</li><li><input type="checkbox"/> SLRE (for lending reallocation)</li><li><input type="checkbox"/> SUBS (for subscription)</li><li><input type="checkbox"/> SWIF (for switch from)</li><li><input type="checkbox"/> SWIT (for switch to)</li><li><input type="checkbox"/> SYND (for syndicate underwriters )</li><li><input type="checkbox"/> TBAC (for TBA closing)</li><li><input type="checkbox"/> TRAD (for trade)</li><li><input type="checkbox"/> TRPO (for triparty repo)</li><li><input type="checkbox"/> TRVO (for triparty reverse repo)</li><li><input type="checkbox"/> TURN (for turnaround)</li></ul> |
| Cum/Ex Indicator                                       | Select the cum/ex indicator from the possible values: <ul style="list-style-type: none"><li><input type="checkbox"/> All (default value)</li><li><input type="checkbox"/> Cum</li><li><input type="checkbox"/> Ex</li></ul>   |
| Opt/Out ISO Settlement Transaction Condition Indicator | Select the opt/out settlement transaction condition indicator from the possible values: <ul style="list-style-type: none"><li><input type="checkbox"/> All (default value)</li><li><input type="checkbox"/> No</li><li><input type="checkbox"/> Yes</li></ul>   |
| Debit Credit Indicator                                 | Select the credit/debit code from the possible values: <ul style="list-style-type: none"><li><input type="checkbox"/> All (default value)</li><li><input type="checkbox"/> Credit</li><li><input type="checkbox"/> Debit</li></ul>  |
| Settlement Currency                                    | Select the eligible currency for settlement in T2S from the drop-down menu.<br>The default value is 'all'.<br>Reference for error message [ ▶ 1115]: <ul style="list-style-type: none"><li><input type="checkbox"/> QMPC054</li></ul>   |

| Settlement Instructions – Search Criteria       |   |
|---|---|
| Country of Issuance - Code                      | Select the country where the security was issued from the drop-down menu.   |
| <b>Other Criteria</b>                           |   |
| Priority  | Select the priority from the possible values: <ul style="list-style-type: none"> <li><input type="checkbox"/> All (default value)</li> <li><input type="checkbox"/> Normal</li> <li><input type="checkbox"/> High</li> <li><input type="checkbox"/> Top</li> <li><input type="checkbox"/> Reserved</li> </ul> |
| Issuer CSD                                      | You can choose to either enter the BIC of the 'Issuer CSD' or to select it from the suggested items in the drop-down menu.<br>Required format is: max. 11 characters (SWIFT-x)  |
| Delivering CSD BIC                              | You can choose to either enter the 'Delivering CSD BIC' or to select it from the suggested items in the drop-down menu.<br>Required format is: max. 11 characters (SWIFT-x)   |
| Receiving CSD BIC                               | You can choose to either enter the 'Receiving CSD BIC' or to select it from the suggested items in the drop-down menu.<br>Required format is: max. 11 characters (SWIFT-x)  |
| Delivering CSD Participant                      | You can choose to either enter the BIC of the 'Delivering CSD Participant' or to select it from the suggested items in the drop-down menu.<br>Required format is: max. 11 characters (SWIFT-x)  |
| Receiving CSD Participant                       | You can choose to either enter the BIC of the 'Receiving CSD Participant' or to select it from the suggested items in the drop-down menu.<br>Required format is: max. 11 characters (SWIFT-x)   |
| Delivering CSD Participant Processing Reference | Enter the delivering CSD participant processing reference.<br>Required format is: max. 34 characters (SWIFT-x)  |
| Receiving CSD Participant Processing Reference  | Enter the receiving CSD participant processing reference.<br>Required format is: max. 34 characters (SWIFT-x)   |

| Settlement Instructions – Search Criteria    |  |
|--|--|
| Delivering CSD Client of the Participant BIC | Enter the 'Delivering CSD Client of the Participant BIC'.<br>Required format is: max. 11 characters (SWIFT-x)  |
| Receiving CSD Client of the Participant BIC  | Enter the 'Receiving CSD Client of the Participant BIC'.<br>Required format is: max. 11 characters (SWIFT-x)   |
| Partial Settlement Indicator                 | Select the partial settlement indicator from the possible values:<br><br><input type="checkbox"/> All (default value)<br><input type="checkbox"/> Yes<br><input type="checkbox"/> No   |
| CoSD Flag                                    | Select the CoSD Flag from the possible values:<br><br><input type="checkbox"/> All (default value)<br><input type="checkbox"/> Yes<br><input type="checkbox"/> No  |
| Range Criteria                               |  |
| Trade Date from                              | Enter the lower bound of the search range for the date from which the trade date is valid or use the <i>calendar</i> icon.<br>Required format is: YYYY-MM-DD<br>References for error messages [ ▶ 1115]:<br><br><input type="checkbox"/> QMPC007<br><input type="checkbox"/> QMPC010<br><input type="checkbox"/> QMPC011 |
| Trade Date to                                | Enter the upper bound of the search range for the date until which the trade date is valid or use the <i>calendar</i> icon.<br>Required format is: YYYY-MM-DD<br>Reference for error message [ ▶ 1115]:<br><br><input type="checkbox"/> QMPC007  |
| Intended Settlement Date from                | Enter the lower bound of the search range for the date from which the intended settlement date is valid or use the <i>calendar</i> icon.<br>Required format is: YYYY-MM-DD<br>References for error messages [ ▶ 1115]:<br><br><input type="checkbox"/> QMPC010   |



| Settlement Instructions – Search Criteria |   |
|---|---|
|   | <input type="checkbox"/> QMPC012  |
| Intended Settlement Date to               | <p>Enter the upper bound of the search range for the date until which the intended settlement date is valid or use the <i>calendar</i> icon.</p> <p>Required format is: YYYY-MM-DD</p> <p>Reference for error message [▶ 1115]:</p> <input type="checkbox"/> QMPC012  |
| Actual Settlement Date and Time from      | <p>Enter the lower bound of the search range for the date and time from which the actual settlement date is valid or use the <i>calendar</i> icon.</p> <p>Required format is: YYYY-MM-DD hh:mm:ss</p> <p>References for error messages [▶ 1115]:</p> <input type="checkbox"/> QMPC011<br><input type="checkbox"/> QMPC013<br><input type="checkbox"/> QMPC014 |
| Actual Settlement Date and Time to        | <p>Enter the upper bound of the search range for the date and time until which the actual settlement date is valid or use the <i>calendar</i> icon.</p> <p>Required format is: YYYY-MM-DD hh:mm:ss</p> <p>Reference for error message [▶ 1115]:</p> <input type="checkbox"/> QMPC014  |
| Quantity/Nominal from                     | <p>Enter the lower bound of the search range for the quantity of securities.</p> <p>Required format is: Decimal Number</p> <p>Reference for error message [▶ 1115]:</p> <input type="checkbox"/> QMPC006  |
| Quantity/Nominal to                       | <p>Enter the upper bound of the search range for the quantity of securities.</p> <p>Required format is: Decimal Number</p> <p>Reference for error message [▶ 1115]:</p> <input type="checkbox"/> QMPC006  |
| Settlement Type                           | <p>Select the settlement type from the possible values:</p> <input type="checkbox"/> All (default value)<br><input type="checkbox"/> Units  |

| Settlement Instructions – Search Criteria |  |
|---|--|
|   | <input type="checkbox"/> Nominal   |
| Settlement Cash Amount More than          | <p>Enter the lower bound of the search range for the settlement cash amount.</p> <p>Required format is: max. 19 digit(s) incl. decimal point (thereof max. 5 decimal places)</p> <p>Reference for error message [ ▶ 1115]:</p> <input type="checkbox"/> QMPC005  |
| Settlement Cash Amount Equal/less         | <p>Enter the upper bound of the search range for the settlement cash amount.</p> <p>Required format is: max. 19 digit(s) incl. decimal point (thereof max. 5 decimal places)</p> <p>Reference for error message [ ▶ 1115]:</p> <input type="checkbox"/> QMPC005  |
| Status Criteria                           |  |
| ISO Settlement status                     | <p>Select the settlement status of the settlement instruction from the possible values:</p> <input type="checkbox"/> All (default value)<br><input type="checkbox"/> Pending<br><input type="checkbox"/> Failing <p>If value 'Settlement Status' field is set to 'Settled' or 'Cancellation Status' field is set to 'Cancelled', this field is disabled.</p> <p>No date search range is allowed for the ISO Settlement Status.</p> |
| Settlement Status                         | <p>Select the settlement status from the possible values:</p> <input type="checkbox"/> All (default value)<br><input type="checkbox"/> Unsettled<br><input type="checkbox"/> Settled<br><input type="checkbox"/> Partially settled   |
| Date and Time from                        | <p>Enter the lower bound of the search range for the date and time from which the settlement status is valid or use the <i>calendar</i> icon.</p> <p>Required format is: YYYY-MM-DD hh:mm:ss</p>   |

| Settlement Instructions – Search Criteria |  |
|---|--|
| Date and Time to                          | Enter the upper bound of the search range for the date and time until which the settlement status is valid or use the <i>calendar</i> icon.<br><br>Required format is: YYYY-MM-DD hh:mm:ss   |
| Matching Status                           | Select the match status from the possible values:<br><input type="checkbox"/> Unmatched<br><input type="checkbox"/> Matched<br><input type="checkbox"/> All (default value)                  |
| Date and Time from                        | Enter the lower bound of the search range for the date and time from which the match status is valid or use the <i>calendar</i> icon.<br><br>Required format is: YYYY-MM-DD hh:mm:ss         |
| Date and Time to                          | Enter the upper bound of the search range for the date and time to which the match status is valid or use the <i>calendar</i> icon.<br><br>Required format is: YYYY-MM-DD hh:mm:ss           |
| Cancellation Status                       | Select the cancellation status from the possible values:<br><input type="checkbox"/> All (default value)<br><input type="checkbox"/> Not cancelled<br><input type="checkbox"/> Cancelled     |
| Date and Time from                        | Enter the lower bound of the search range for the date and time from which the cancellation status is valid or use the <i>calendar</i> icon.<br><br>Required format is: YYYY-MM-DD hh:mm:ss  |
| Date and Time to                          | Enter the upper bound of the search range for the date and time until which the cancellation status is valid or use the <i>calendar</i> icon.<br><br>Required format is: YYYY-MM-DD hh:mm:ss |
| CSD Hold Status                           | Select the CSD hold status from the possible values:<br><input type="checkbox"/> All (default value)<br><input type="checkbox"/> No<br><input type="checkbox"/> Yes                          |
| Date and Time from                        | Enter the lower bound of the search range for the date and time from which the CSD hold status is valid or use the <i>calendar</i> icon.   |

| Settlement Instructions – Search Criteria |   |
|---|---|
|   | Required format is: YYYY-MM-DD hh:mm:ss   |
| Date and Time to                          | Enter the upper bound of the search range for the date and time until which the CSD hold status is valid or use the <i>calendar</i> icon.<br>Required format is: YYYY-MM-DD hh:mm:ss            |
| Party Hold Status                         | Select the party hold status from the possible values:<br><input type="checkbox"/> All (default value)<br><input type="checkbox"/> No<br><input type="checkbox"/> Yes                           |
| Date and Time from                        | Enter the lower bound of the search range for the date and time from which the party hold status is valid or use the <i>calendar</i> icon.<br>Required format is: YYYY-MM-DD hh:mm:ss           |
| Date and Time to                          | Enter the upper bound of the search range for the date and time until which the party hold status is valid or use the <i>calendar</i> icon.<br>Required format is: YYYY-MM-DD hh:mm:ss          |
| CSD Validation Hold Status                | Select the party hold status from the possible values:<br><input type="checkbox"/> All (default value)<br><input type="checkbox"/> No<br><input type="checkbox"/> Yes                           |
| Date and Time from                        | Enter the lower bound of the search range for the date and time from which the CSD validation hold status is valid or use the <i>calendar</i> icon.<br>Required format is: YYYY-MM-DD hh:mm:ss  |
| Date and Time to                          | Enter the upper bound of the search range for the date and time until which the CSD validation hold status is valid or use the <i>calendar</i> icon.<br>Required format is: YYYY-MM-DD hh:mm:ss |
| CoSD Hold Status                          | Select the CoSD hold status from the possible values:<br><input type="checkbox"/> All (default value)<br><input type="checkbox"/> No<br><input type="checkbox"/> Yes                            |

| Settlement Instructions – Search Criteria |  |
|---|--|
| Date and Time from                        | Enter the lower bound of the search range for the date and time from which the CoSD hold status is valid or use the <i>calendar</i> icon.<br><br>Required format is: YYYY-MM-DD hh:mm:ss   |
| Date and Time to                          | Enter the upper bound of the search range for the date and time until which the CoSD hold status is valid or use the <i>calendar</i> icon.<br><br>Required format is: YYYY-MM-DD hh:mm:ss  |
| Approval Status                           | Select the approval status from the possible values:<br><br><input type="checkbox"/> All (default value)<br><input type="checkbox"/> Approved<br><input type="checkbox"/> Awaiting Approval<br><input type="checkbox"/> Rejected<br><input type="checkbox"/> Revoked |
| Date and Time from                        | Enter the lower bound of the search range for the date and time from which the approval status is valid or use the <i>calendar</i> icon.<br><br>Required format is: YYYY-MM-DD hh:mm:ss  |
| Date and Time to                          | Enter the upper bound of the search range for the date and time until which the approval status is valid or use the <i>calendar</i> icon.<br><br>Required format is: YYYY-MM-DD hh:mm:ss   |
| Settlement Instructions – List            |  |
| Actor Reference                           | Shows the identification of the referenced instruction assigned by the T2S actor.  |
| Instructing Party BIC                     | Shows the BIC of the instructing party.  |
| Instructing Party Parent BIC              | Shows the parent BIC of the instructing party.   |
| Securities Account Number                 | Shows the securities account of the referenced instruction.  |
| ISIN                                      | Shows the ISIN of the settlement instruction.  |
| Securities Description                    | Shows the description of the selected ISIN.  |
| Securities Movement Type Code             | Shows the securities movement type code from the possible values:  |

| Settlement Instructions – Search Criteria |  |
|---|--|
|   | <input type="checkbox"/> Delivery<br><input type="checkbox"/> Receive  |
| Quantity/Nominal                          | Shows quantity of financial instrument in units, original face amount or current face amount.<br><br>The Unit or Face amount corresponds to the original settlement quantity.                        |
| Settlement Amount                         | Shows the amount stated in the LCMM Instruction.   |
| Settlement Status                         | Shows the settlement status of the instruction from the possible values:<br><br><input type="checkbox"/> Unsettled<br><input type="checkbox"/> Settled<br><input type="checkbox"/> Partially settled |
| Matching Status                           | Shows the match status of the instruction from the possible values:<br><br><input type="checkbox"/> Unmatched<br><input type="checkbox"/> Matched  |
| Cancellation Status                       | Shows the cancellation status of the instruction from the possible values:<br><br><input type="checkbox"/> Not cancelled<br><input type="checkbox"/> Cancelled                                       |

## Buttons

| Buttons |   |
|---------|---|
| Search  | <p>This function enables you to start a search according to the criteria entered. The results are displayed in a list on the next screen.</p> <p>If the search retrieves a single record, the <i>details</i> screen is displayed directly.</p> <p>Next screens:</p> <ul style="list-style-type: none"> <li><input type="checkbox"/> <i>Settlement instructions – search/list</i> screen</li> <li><input type="checkbox"/> <i>Settlement instruction – details</i> screen [▶ 191]</li> </ul> <p>References for error messages [▶ 1115]:</p> <ul style="list-style-type: none"> <li><input type="checkbox"/> QMPC005</li> <li><input type="checkbox"/> QMPC006</li> <li><input type="checkbox"/> QMPC007</li> <li><input type="checkbox"/> QMPC010</li> </ul> |

|         |  |
|---------|--|
|         | <input type="checkbox"/> QMPC011<br><input type="checkbox"/> QMPC012<br><input type="checkbox"/> QMPC013<br><input type="checkbox"/> QMPC014<br><input type="checkbox"/> QMPC018<br><input type="checkbox"/> QMPC030<br><input type="checkbox"/> QMPC031<br><input type="checkbox"/> QMPC032<br><input type="checkbox"/> QMPC048<br><input type="checkbox"/> QMPC054 |
| Reset   | <p>This function enables you to set all fields to default value and blanks out all optional fields.</p> <p>Next screen:</p> <input type="checkbox"/> <i>Settlement instructions – search/list</i> screen [▶ 1115]  |
| New     | <p>This function enables you to create a new settlement instruction.</p> <p>Next screen:</p> <input type="checkbox"/> <i>Settlement instruction - new</i> screen [▶ 210]   |
| Details | <p>This function enables you to display the details of the selected instruction.</p> <p>Next screen:</p> <input type="checkbox"/> <i>Settlement instruction – details</i> screen [▶ 191]   |

## 2.2.2.18 Settlement Instruction - Details Screen

### Context of Usage

This screen displays detailed information on the selected settlement instruction. You can check the data and proceed further by clicking on the buttons below.

You can perform the following foreseen actions: check the specific details of a settlement instruction, amend it, cancel it, hold it or release it, see its revisions/ audit trail and status history or its related messages copy the shown instruction to create a new similar one as well as searching for the associated penalties of the settlement instruction or searching for the details of its matched settlement instruction.

This screen is not relevant for CB users.

---

|                      |  |
|----------------------|--|
| <b>Screen Access</b> | <ul style="list-style-type: none"><li>□ Securities &gt;&gt; Settlement &gt;&gt; Settlement Instructions &gt;&gt; <i>Settlement instructions – search/list</i> screen &gt;&gt; Click on the <i>search</i> button &gt;&gt; <i>Settlement instructions – search/list</i> screen &gt;&gt; Click on the <i>details</i> button</li><li>□ Securities &gt;&gt; Settlement &gt;&gt; Settlement Instructions &gt;&gt; <i>Settlement instructions – search/list</i> screen &gt;&gt; Click on the <i>search</i> button &gt;&gt; <i>Settlement instructions Details</i> screen &gt;&gt; Click on the <i>Matched Instruction</i> button to access the <i>Details Screen</i> of the matched settlement instruction</li></ul>  |
| <b>Privileges</b>    | To use this screen, you need the following privilege: <ul style="list-style-type: none"><li>□ Settlement instruction query</li></ul>   |
| <b>References</b>    | <p><b>User Instructions Part</b></p> <p>This screen is part of the following business scenarios:</p> <ul style="list-style-type: none"><li>□ Add a link for a settlement instruction [▶ 703]</li><li>□ Amend the partial settlement indicator for a settlement instruction [▶ 706]</li><li>□ Amend the priority for a settlement instruction [▶ 707]</li><li>□ Copy a settlement instruction [▶ 690]</li><li>□ Cancel a settlement instruction [▶ 727]</li><li>□ Put a settlement instruction on CSD hold [▶ 715]</li><li>□ Put a settlement instruction on party hold [▶ 713]</li><li>□ Release a settlement instruction from CoSD hold [▶ 722]</li><li>□ Release a settlement instruction from CSD hold [▶ 720]</li><li>□ Release a settlement instruction from CSD validation hold [▶ 724]</li><li>□ Release a settlement instruction from party hold [▶ 717]</li><li>□ Partially release a settlement instruction from party hold [▶ 718]</li><li>□ Remove a link for a settlement instruction [▶ 709]</li><li>□ View Alleged Cancellation Instructions [▶ 730]</li><li>□ View settlement instruction details [▶ 701]</li><li>□ View List of Penalties [▶ 742]</li><li>□ View the Individual Penalty Details [▶ 735]</li></ul> <p><b>Business Functionality Document</b></p> <p>This screen corresponds to the following business function:</p> <ul style="list-style-type: none"><li>□ Display instruction details (T2S.GUI.SESE.INX.0030).</li></ul> |

---



Screenshot

| SECURITIES   | CASH   | SERVICES  | MONITORING |
|--|--|---|------------|
| <p>Securities &gt; Settlement &gt; Settlement Instructions &gt; Settlement Instruction Details</p> |  |   |            |
| <p><b>Settlement Instruction</b></p>   |  |   |            |
| Securities Account Owner Reference<br>---  | Securities Account Servicer Reference<br>--- | Third Party Reference<br>REST-S118  |            |
| T2S Reference<br>2304120667173831  | T2S Matching Reference<br>012306689537000    |   |            |
| User Identification<br>OPERATOR  | Instructing Party BIC<br>CDESISEXXX          | Instructing Party Parent BIC<br>CDESISEXXX  |            |
| Settlement Status<br>Unsettled   | Matching Status<br>Matched                   | Partial Settlement Indicator<br>---   |            |
| ISO Settlement Status<br>Faling  |  |   |            |
| Matched Settlement Amount<br>---   | Matched Priority<br>Normal                   | Matched Partial Settlement Indicator<br>Partial Settlement Quantity Threshold allowed |            |
| <p><b>Securities Movement Type Code</b><br/>Delivery</p>   |  |   |            |
| ISIN<br>SIEURHOCE103   | Securities Description<br>F.A. EUR CSDE      | Securities Account Number<br>CDESISEXXXCSDMP001                                       |            |
| Securities Account Owner BIC<br>CDESISEXXX   | Original Settlement Quantity<br>20,000       | Settlement Type<br>Units  |            |
|  | Settled Settlement Quantity<br>---           |   |            |
| Payment Type Code<br>FREE  | Debit Credit Indicator<br>---                | Dedicated Cash Account Number<br>---  |            |
| Original Settlement Amount<br>---  |  |   |            |
| Settled Settlement Amount<br>---   |  |   |            |
| Entry Date and Time<br>2023-04-12 10:24:36.101   | Intended Settlement Date<br>2023-04-12       | Trade Date<br>2023-04-12  |            |
| Actual Settlement Date<br>---  | Cancellation Date<br>---                     |   |            |
| Accepted Timestamp<br>2023-04-12 10:24:37.904  | Matched Timestamp<br>2023-04-12 10:24:38.222 |   |            |
| <p><b>Receiving Depository BIC</b><br/>CDESISEXXX</p>  |  |   |            |
| <p><b>Receiving CSD Participant</b></p>  |  |   |            |
| Party BIC<br>PARESISEXX1   | Processing Identification<br>---             | Securities Account<br>PARESISEXX1CSDPP001   |            |
| <p><b>Client of the Receiving CSD Participant</b></p>  |  |   |            |
| Party BIC<br>---   | Name<br>---                                  | Identification<br>---   |            |
|  |  | Issuer<br>---   |            |
|  |  | Schema Name<br>---  |            |
| <p><b>Delivering Depository BIC</b><br/>CDESISEXXX</p>   |  |   |            |
| <p><b>Delivering CSD Participant</b></p>   |  |   |            |
| Party BIC<br>CDESISEXXX  | Processing Identification<br>---             | Securities Account<br>CDESISEXXXCSDMP001  |            |
| <p><b>Client of the Delivering CSD Participant</b></p>   |  |   |            |
| Party BIC<br>---   | Name<br>---                                  | Identification<br>---   |            |
|  |  | Issuer<br>---   |            |
|  |  | Schema Name<br>---  |            |
| <p><b>Detailed Information</b></p>   |  |   |            |
| Priority<br>NORMAL   | Allowed Modification Flag<br>Yes             | CoSD Flag<br>No   |            |
| Corporate Action Event Identification<br>---   | Common Reference<br>---                      | Beneficial Ownership<br>---   |            |
| Repo Reference<br>---  | Securities Transaction Type<br>TRAD          | Cum/Ex Indicator<br>---   |            |
| <p>Settlement Transaction Condition Indicator</p>  |  |   |            |
| <p>No records found.</p>   |  |   |            |

**Status Information**

|  |                               |                             |
|--|-------------------------------|-----------------------------|
| CSD Validation Hold Status<br>Released | CSD Hold Status<br>Released   | CSD Hold Status<br>Released |
| Party Hold Status<br>Released          |                               |                             |
| Cancellation Status<br>NCAN            | Cancellation Requested<br>--- |                             |

**Reason Code Reference**

Link - SPST003 - Settlement instruction is unsettled because a linked settlement instruction is 'on hold'

Link - SPST008 - Settlement instruction is unsettled because its counterpart settlement instruction is linked to a settlement instruction 'on hold'

Link - SPST021 - Settlement instruction is unsettled because another instruction stating a link WITH or BEFORE this instruction is 'on hold'

**Link**

| Link Type                  | Reference Type           | Reference                | Reference Owner |
|----------------------------|--------------------------|--------------------------|-----------------|
| USD                        | T2S reference            | 238412867173812          | ---             |
| Pool Instruction Reference | Pool Instruction Counter | Pool Reference Owner BIC | ---             |

**Use of Restriction**

|                              |                                    |
|------------------------------|------------------------------------|
| Cash Sub Balance Type<br>--- | Securities Sub Balance Type<br>--- |
|------------------------------|------------------------------------|

**Restriction Reference**

No records found.

**Additional Receiving Parties**

|                          |      |                |
|--------------------------|------|----------------|
| <b>Receiving Party 3</b> |      |                |
| Party BIC                | Name | Identification |
| ---                      | ---  | ---            |
|                          |      | Issuer         |
|                          |      | Schema Name    |
|                          |      | ---            |
| <b>Receiving Party 4</b> |      |                |
| Party BIC                | Name | Identification |
| ---                      | ---  | ---            |
|                          |      | Issuer         |
|                          |      | Schema Name    |
|                          |      | ---            |
| <b>Receiving Party 5</b> |      |                |
| Party BIC                | Name | Identification |
| ---                      | ---  | ---            |
|                          |      | Issuer         |
|                          |      | Schema Name    |
|                          |      | ---            |

**Additional Delivering Parties**

|                           |      |                |
|---------------------------|------|----------------|
| <b>Delivering Party 3</b> |      |                |
| Party BIC                 | Name | Identification |
| ---                       | ---  | ---            |
|                           |      | Issuer         |
|                           |      | Schema Name    |
|                           |      | ---            |
| <b>Delivering Party 4</b> |      |                |
| Party BIC                 | Name | Identification |
| ---                       | ---  | ---            |
|                           |      | Issuer         |
|                           |      | Schema Name    |
|                           |      | ---            |
| <b>Delivering Party 5</b> |      |                |
| Party BIC                 | Name | Identification |
| ---                       | ---  | ---            |
|                           |      | Issuer         |
|                           |      | Schema Name    |
|                           |      | ---            |

**Other Information**

|                            |                                       |                           |
|----------------------------|---------------------------------------|---------------------------|
| <b>Deal Price</b>          |                                       |                           |
| Value Amount               | Value Currency                        | ---                       |
| ---                        | ---                                   | ---                       |
| Value Rate                 | Value Type                            | Yielded                   |
| ---                        | ---                                   | ---                       |
| <b>Foreign Exchange</b>    |                                       |                           |
| Exchange Rate              | Quoted Currency                       | ---                       |
| ---                        | ---                                   | ---                       |
| Resulting Amount           | Resulting Amount Currency             | Unit Currency             |
| ---                        | ---                                   | ---                       |
| <b>Place of Trade</b>      |                                       |                           |
| Place of Trade Description | Place of Trade Market Identifier Code | Place of Trade Code       |
| ---                        | ---                                   | ---                       |
| Proprietary Identification | Issuer Name                           | Schema Name               |
| ---                        | ---                                   | ---                       |
| <b>Other</b>               |                                       |                           |
| Number of Days Accrued     | Original Ordered Amount               | Original Ordered Currency |
| 0                          | ---                                   | ---                       |
| Market Client Side Code    | Place of Clearing                     | ---                       |
| ---                        | ---                                   | ---                       |

Amendment Instr. | Hold/Release Instr. | Cancellation Instr. | Revisions | Status History | Related Outbound Messages | Related Inbound Messages | Copy | Recycle | Associated Penalties | Links | Matched Instruction

Illustration 57: Settlement instruction - details screen

**Field**

**Description**

| Settlement Instruction                    |   |
|---|---|
| <p>Securities Account Owner Reference</p> | <p>Shows the reference assigned by the account owner to the settlement instruction.</p> <p>Only one of the three references can be the T2S actor reference.</p> |

| Settlement Instruction                |   |
|---------------------------------------|---|
| Securities Account Servicer Reference | <p>Shows the reference assigned by the account servicer to the settlement instruction.</p> <p>Only one of the three references can be the T2S actor reference.</p>  |
| Third Party Reference                 | <p>Shows the reference assigned by the third party to the settlement instruction.</p> <p>Only one of the three references can be the T2S actor reference.</p>   |
| T2S Reference                         | <p>Shows the reference assigned by T2S to the settlement instruction.</p>   |
| T2S Matching Reference                | <p>Shows the common reference assigned by T2S to all the settlement instructions comprising a transaction.</p> <p>Only shown if the settlement instruction is matched.</p>  |
| User Identification                   | <p>Shows the identification of the user who introduced the settlement instruction.</p>  |
| Instructing Party BIC                 | <p>Shows the BIC of the instructing party of the settlement instruction.</p>  |
| Instructing Party Parent BIC          | <p>Shows the BIC of the instructing party parent of the settlement instruction.</p>   |
| Matching Status                       | <p>Shows the match status of the settlement instruction from the possible values:</p> <ul style="list-style-type: none"><li><input type="checkbox"/> Unmatched</li><li><input type="checkbox"/> Matched</li></ul>   |
| Settlement Status                     | <p>Shows the settlement status of the settlement instruction from the possible values:</p> <ul style="list-style-type: none"><li><input type="checkbox"/> Unsettled</li><li><input type="checkbox"/> Settled</li><li><input type="checkbox"/> Partially settled</li></ul> |
| ISO Settlement Status                 | <p>Shows the current ISO settlement status of the settlement instruction from the possible values:</p> <ul style="list-style-type: none"><li><input type="checkbox"/> Pending</li><li><input type="checkbox"/> Failing</li></ul>  |
| Partial Settlement Indicator          | <p>Shows the value of the partial settlement indicator of the settlement instruction from the possible values:</p> <ul style="list-style-type: none"><li><input type="checkbox"/> Partial not allowed</li></ul>   |

| Settlement Instruction               |  |
|--------------------------------------|--|
|                                      | <input type="checkbox"/> Partial settlement cash threshold allowed<br><input type="checkbox"/> Partial settlement quantity threshold allowed<br><input type="checkbox"/> Partial allowed   |
| Matched Settlement Amount            | Shows the matched effective amount on the transaction.   |
| Matched Priority                     | Shows the priority of the transaction from the possible values:<br><input type="checkbox"/> Normal<br><input type="checkbox"/> High<br><input type="checkbox"/> Top<br><input type="checkbox"/> Reserved   |
| Matched Partial Settlement Indicator | Shows the value of the partial settlement indicator of the transaction from the possible values:<br><input type="checkbox"/> Partial not allowed<br><input type="checkbox"/> Partial settlement cash threshold allowed<br><input type="checkbox"/> Partial settlement quantity threshold allowed |
| Securities Movement Type Code        | Shows if the movement on a securities account results from a deliver or a receive instruction from the possible values:<br><input type="checkbox"/> Deliver<br><input type="checkbox"/> Receive  |
| ISIN                                 | Shows the ISIN code of the security.   |
| Securities Description               | Shows the description of the security.   |
| Securities Account Number            | Shows the account to or from which a securities entry is made.   |
| Securities Account Owner BIC         | Shows the BIC of the securities account owner.   |
| Original Settlement Quantity         | Shows the quantity stated in the settlement instruction.   |
| Settlement Type                      | Shows the type of settlement foreseen for the security stated in the settlement instruction from the possible values:<br><input type="checkbox"/> Units  |

| Settlement Instruction            |  |
|-----------------------------------|--|
|                                   | <input type="checkbox"/> Face Amount   |
| Settled Settlement Quantity       | Shows the total quantity settled so far.   |
| Payment Type Code                 | Shows if the transaction is to be settled with or without payment from the possible values:<br><br><input type="checkbox"/> Against payment settlement<br><br><input type="checkbox"/> Free of payment |
| Debit Credit Indicator            | Shows if the original settlement amount is to be credited or debited from the possible values:<br><br><input type="checkbox"/> Credit<br><br><input type="checkbox"/> Debit                            |
| T2S Dedicated Cash Account Number | Shows the cash account stated in the settlement instruction.   |
| Original Settlement Amount        | Shows the settlement amount stated in the settlement instruction.  |
| Currency                          | Shows the currency stated in the settlement instruction.   |
| Settled Settlement Amount         | Shows the total settlement amount settled so far.  |
| Currency                          | Shows the currency stated in the settlement instruction.   |
| Entry Date Time                   | Shows the date and timestamp when the settlement instruction has been created.<br><br>Displayed format is: YYYY-MM-DD hh:mm:ss:µsµsµsµsµs  |
| Intended Settlement Date          | Shows the date at which the settlement instruction becomes eligible to be submitted to settlement.<br><br>Displayed format is: YYYY-MM-DD  |
| Trade Date                        | Shows the date at which the contract was made.<br><br>Displayed format is: YYYY-MM-DD  |
| Actual Settlement Date and Time   | Shows the business date and the calendar time when the last settlement occurred.<br><br>Displayed format is: YYYY-MM-DD hh:mm:ss:µsµsµsµsµs  |
| Cancellation Date                 | Shows the business date when the settlement instruction has been cancelled.<br><br>Displayed format is: YYYY-MM-DD   |
| Accepted Timestamp (SF1)          | Shows the accepted timestamp of the settlement instruction.  |

| Settlement Instruction                        |  |
|---|--|
|   | Displayed format is: YYYY-MM-DD hh:mm:ss:μsμsμsμsμs  |
| Matched Timestamp (SF2)                       | Shows the matched timestamp of the settlement instruction.<br><br>In case the settlement instruction is unmatched no timestamp will be shown.<br><br>Displayed format is: YYYY-MM-DD hh:mm:ss:μsμsμsμsμs |
| Receiving Depository BIC                      | Shows the BIC of the receiving depository.   |
| Receiving CSD Participant BIC                 | Shows the BIC of the receiving CSD participant.  |
| Processing Identification                     | Shows the reference of the instruction assigned by the receiving CSD participant.  |
| Receiving CSD Participant Securities Account  | Shows the Securities account of the receiving CSD participant.   |
| Client of the Receiving CSD Participant BIC   | Shows the BIC of the client of the receiving CSD participant.  |
| Name  | Shows the name and address of the client of the receiving CSD participant.   |
| Identification                                | Shows the proprietary information, often a code, issued by the data source scheme issuer.  |
| Issuer  | Shows the entity that assigns the identification.  |
| Schema Name                                   | Shows the short textual description of the schema.   |
| Delivering Depository BIC                     | Shows the BIC of the delivering depository.  |
| Delivering CSD Participant BIC                | Shows the BIC of the delivering CSD participant.   |
| Processing Identification                     | Shows the reference of the instruction assigned by the delivering CSD participant.   |
| Delivering CSD Participant Securities Account | Shows the securities account of the delivering CSD participant.  |
| Client of the Delivering CSD Participant BIC  | Shows the BIC of the client of the delivering CSD participant.   |

| Settlement Instruction                |  |
|---------------------------------------|--|
| Name                                  | Shows the name and address of the client of the delivering CSD participant.  |
| Identification                        | Shows the proprietary information, often a code, issued by the data source scheme issuer.  |
| Issuer                                | Shows the entity that assigns the identification.  |
| Schema Name                           | Shows the short textual description of the schema.   |
| Detailed Information                  |  |
| Priority*                             | Shows the level of priority assigned to the settlement instruction from the possible values: <ul style="list-style-type: none"> <li><input type="checkbox"/> Normal</li> <li><input type="checkbox"/> High</li> <li><input type="checkbox"/> Top</li> <li><input type="checkbox"/> Reserved</li> </ul> |
| Allowed Modification Flag             | Shows if a settlement instruction is non-modifiable by CSD participants from the possible values: <ul style="list-style-type: none"> <li><input type="checkbox"/> No</li> <li><input type="checkbox"/> Yes</li> </ul>  |
| CoSD Flag                             | Shows if the Settlement Instruction has been identified as CoSD.   |
| Corporate Action Event Identification | Shows the identification assigned by the account servicer to unambiguously identify a corporate action event.  |
| Common Reference                      | Shows the reference provided by the T2S actor when the LCMM instruction is already matched or in order to facilitate the matching within T2S.  |
| Beneficial Ownership                  | Shows if there is a change of beneficial ownership: <ul style="list-style-type: none"> <li><input type="checkbox"/> Empty (default value)</li> <li><input type="checkbox"/> Yes</li> <li><input type="checkbox"/> No</li> </ul>  |
| Repo Reference                        | Shows the identification of a collateral transaction as assigned by the instructing party.   |
| Securities Transaction Type*          | Shows the securities transaction type expressed as an ISO 20022 code from the possible values: <ul style="list-style-type: none"> <li><input type="checkbox"/> AUTO (for auto-collateralisation)</li> <li><input type="checkbox"/> BYIY (for buy-in)</li> </ul>  |

**Settlement Instruction**

- BSBK (for buy sell back)
- CLAI (for market claim)
- CNCB (for central bank collateral operation)
- COLI (for collateral in)
- COLO (for collateral out)
- CONV (for depository receipt conversion)
- CORP (for corporate action)
- ETFT (for exchange traded funds)
- FCTA (for factor update)
- INSP (for move of stock)
- ISSU (for depository receipt issue)
- MKDW (for mark down)
- MKUP (for mark up)
- NETT (for netting)
- NSYN (for non syndicated)
- OWNE (for external account transfer)
- OWNI (for internal account transfer)
- PAIR (for pair off)
- PLAC (for placement)
- PORT (for portfolio move)
- REAL (for realignment)
- REBL (for rebalancing)
- REDI (for withdrawal)
- REDM (for redemption)
- RELE (for depository receipt release cancellation)
- REPU (for repo)
- RODE (for return delivery without matching)
- RVPO (for reverse repurchase agreement)
- SBBK (for sell buy back)
- SBRE (for borrowing reallocation)
- SECB (for securities borrowing)
- SECL (for securities lending)



| Settlement Instruction                     |  |
|--|--|
|  | <ul style="list-style-type: none"> <li><input type="checkbox"/> SLRE (for lending reallocation)</li> <li><input type="checkbox"/> SUBS (for subscription)</li> <li><input type="checkbox"/> SWIF (for switch from)</li> <li><input type="checkbox"/> SWIT (for switch to)</li> <li><input type="checkbox"/> SYND (for syndicate underwriters )</li> <li><input type="checkbox"/> TBAC (for TBA closing)</li> <li><input type="checkbox"/> TRAD (for trade)</li> <li><input type="checkbox"/> TRPO (for triparty repo)</li> <li><input type="checkbox"/> TRVO (for triparty reverse repo)</li> <li><input type="checkbox"/> TURN (for turnaround)</li> </ul>  |
| Cum/EX Indicator                           | <p>Shows whether the contract was traded cum or ex coupon from the possible values:</p> <ul style="list-style-type: none"> <li><input type="checkbox"/> Empty</li> <li><input type="checkbox"/> CUM</li> <li><input type="checkbox"/> EX</li> </ul>  |
| Settlement Transaction Condition Indicator | <p>Shows the Settlement Transaction Condition Indicator from the possible values (This field can show multiple Settlement Transaction Condition Indicators):</p> <ul style="list-style-type: none"> <li><input type="checkbox"/> Empty (default value)</li> <li><input type="checkbox"/> ADEA (accept after regular settlement deadline)</li> <li><input type="checkbox"/> ASGN (assignment)</li> <li><input type="checkbox"/> BUTC (buy to cover)</li> <li><input type="checkbox"/> BSSP (buy in partially succesful)</li> <li><input type="checkbox"/> CLEN (clean)</li> <li><input type="checkbox"/> DIRT (dirty)</li> <li><input type="checkbox"/> DLWM (delivery without matching)</li> <li><input type="checkbox"/> DRAW (drawn)</li> <li><input type="checkbox"/> EXER (exercised)</li> <li><input type="checkbox"/> EXPI (expired)</li> <li><input type="checkbox"/> FRCL (free clean settlement)</li> <li><input type="checkbox"/> KNOC (knocked out)</li> <li><input type="checkbox"/> NOMC (no automatic market claim)</li> <li><input type="checkbox"/> PENS (pending sale)</li> </ul> |

| Settlement Instruction     |   |
|----------------------------|---|
|                            | <input type="checkbox"/> PHYS (physical)<br><input type="checkbox"/> RESI (residual)<br><input type="checkbox"/> RHYP (rehypothecation)<br><input type="checkbox"/> RPTO (reporting)<br><input type="checkbox"/> SHOR (short sell)<br><input type="checkbox"/> SPDL (special delivery)<br><input type="checkbox"/> SPST (split settlement)<br><input type="checkbox"/> TRAN (transformation)<br><input type="checkbox"/> TRIP (triparty segregation)<br><input type="checkbox"/> UNEX (unexposed) |
| Status Information         |   |
| CSD Validation Hold Status | Shows the CSD validation hold status of the settlement instruction from the possible values:<br><input type="checkbox"/> No<br><input type="checkbox"/> Yes   |
| CoSD Hold Status           | Shows the CoSD hold status of the settlement instruction from the possible values:<br><input type="checkbox"/> No<br><input type="checkbox"/> Yes   |
| CSD Hold Status            | Shows the CSD hold status of the settlement instruction from the possible values:<br><input type="checkbox"/> No<br><input type="checkbox"/> Yes  |
| Party Hold Status          | Shows the party hold status of the settlement instruction from the possible values:<br><input type="checkbox"/> No<br><input type="checkbox"/> Yes  |
| Cancellation Status        | Shows the cancellation status of the settlement instruction from the possible values:<br><input type="checkbox"/> Not cancelled<br><input type="checkbox"/> Cancelled   |
| Cancellation Re-quested    | Shows if the settlement instruction has been requested for cancellation by its counterpart from the possible values:  |

| Settlement Instruction     |   |
|----------------------------|---|
|                            | <input type="checkbox"/> Empty (default value)<br><input type="checkbox"/> Yes<br><p>This situation occurs when the counterparty's cancellation instruction is processed in T2S.</p>  |
| Reason Code Reference      | Shows the applicable reason code(s) for the cancellation of the settlement instruction, or an unsuccessful attempt of settlement.   |
| Link                       |   |
| <b>Linkages</b>            |   |
| Pool Instruction Reference | Shows the collective reference that identifies a set of messages.   |
| Pool Instruction Counter   | Shows the pool identification of the settlement instruction within the pool reference.  |
| Pool Reference Owner BIC   | Shows the BIC of the owner of the Pool Instruction Reference.   |
| Link (List)                |   |
| <b>Link Type</b>           |   |
| Link Type                  | <p>Shows the link processing position of the settlement instruction from the possible values:</p> <input type="checkbox"/> After<br><input type="checkbox"/> Before<br><input type="checkbox"/> With<br><input type="checkbox"/> Info   |
| Reference Type             | <p>Shows the reference type of the instruction to be linked/unlinked to from the possible values:</p> <input type="checkbox"/> Account Owner Settlement Instruction Reference<br><input type="checkbox"/> Account Owner Intra Balance Movement Reference<br><input type="checkbox"/> Account Owner Intra Position Movement Reference<br><input type="checkbox"/> Account Servicer Reference<br><input type="checkbox"/> Third Party reference<br><input type="checkbox"/> T2S reference |
| Reference                  | Shows the identification of the instruction to be linked/unlinked to.   |

| Settlement Instruction        |  |
|-------------------------------|--|
| Reference Owner               | Shows the BIC of the instructing party of the instruction to be linked/unlinked to.<br><br>This field is only filled in if the 'Reference Type' is set to any value different than 'T2S reference'.  |
| Use Of Restriction            |  |
| Cash Sub Balance Type         | Shows a code defined by the CB to identify the restriction on cash.  |
| Securities Sub Balance Type   | Shows a code defined by the CSD to identify the restriction on securities. If it is a delivering instruction, the Delivering Securities Sub Balance Type is shown; if it is a receiving instruction, the Receiving Securities Sub Balance Type is shown. |
| Use Of Restriction (List)     |  |
| Restriction Reference         | Shows the reference of a restricted cash balance or securities position included in the settlement instruction.  |
| Additional Delivering Parties |  |
| <b>Delivering Party 3</b>     |  |
| BIC                           | Shows the BIC of the client of the delivering CSD participant.   |
| Name                          | Shows the name of the party.   |
| Identification                | Shows proprietary information, often a code, issued by the data source scheme issuer.  |
| Issuer                        | Shows the entity that assigns the identification.  |
| Schema Name                   | Shows a short textual description of the scheme.   |
| <b>Delivering Party 4</b>     |  |
| BIC                           | Shows the BIC of the client of the delivering CSD participant.   |
| Name                          | Shows the name of the party.   |
| Identification                | Shows proprietary information, often a code, issued by the data source scheme issuer.  |
| Issuer                        | Shows the entity that assigns the identification.  |
| Schema Name                   | Shows a short textual description of the scheme.   |
| <b>Delivering Party 5</b>     |  |
| BIC                           | Shows the BIC of the client of the delivering CSD participant.   |

| <b>Settlement Instruction</b>       |   |
|-------------------------------------|---|
| Name                                | Shows the name of the party.  |
| Identification                      | Shows proprietary information, often a code, issued by the data source scheme issuer. |
| Issuer                              | Shows the entity that assigns the identification.                                     |
| Schema Name                         | Shows a short textual description of the scheme.                                      |
| <b>Additional Receiving Parties</b> |   |
| <b>Receiving Party 3</b>            |   |
| BIC                                 | Shows the BIC of the client of the receiving CSD participant.                         |
| Name                                | Shows the name of the party.  |
| Identification                      | Shows proprietary information, often a code, issued by the data source scheme issuer. |
| Issuer                              | Shows the entity that assigns the identification.                                     |
| Schema Name                         | Shows a short textual description of the scheme.                                      |
| <b>Receiving Party 4</b>            |   |
| BIC                                 | Shows the BIC of the client of the receiving CSD participant.                         |
| Name                                | Shows the name of the party.  |
| Identification                      | Shows proprietary information, often a code, issued by the data source scheme issuer. |
| Issuer                              | Shows the entity that assigns the identification.                                     |
| Schema Name                         | Shows a short textual description of the scheme.                                      |
| <b>Receiving Party 5</b>            |   |
| BIC                                 | Shows the BIC of the client of the receiving CSD participant.                         |
| Name                                | Shows the name of the party.  |
| Identification                      | Shows proprietary information, often a code, issued by the data source scheme issuer. |
| Issuer                              | Shows the entity that assigns the identification.                                     |
| Schema Name                         | Shows a short textual description of the scheme.                                      |
| <b>Other Information</b>            |   |
| <b>Deal Price</b>                   |   |
| Value Amount                        | Shows the value of the amount of the deal price.                                      |
| Value Currency                      | Shows the currency of the amount of the deal price.                                   |

| Settlement Instruction                |  |
|---------------------------------------|--|
| Value Rate                            | Shows the price expressed as a rate.   |
| Value Type                            | Shows the type of value in which the price is expressed from the possible values: <ul style="list-style-type: none"> <li><input type="checkbox"/> Empty</li> <li><input type="checkbox"/> Discount</li> <li><input type="checkbox"/> Par</li> <li><input type="checkbox"/> Premium</li> </ul>  |
| Yielded                               | Shows whether the price is expressed as a yield.   |
| Foreign Exchange                      |  |
| Exchange Rate                         | Shows the factor used for the conversion of an amount from one currency into another. This reflects the price at which one currency was bought with another currency.  |
| Quoted Currency                       | Shows the currency into which the base currency is converted in a currency exchange.   |
| Resulting Amount                      | Shows the counter value of a foreign exchange conversion.  |
| Resulting Amount Currency             | Shows the currency of the counter value of a foreign exchange conversion.  |
| Unit Currency                         | Shows the currency into which the base currency is converted in a currency exchange for unit.  |
| Place of Trade                        |  |
| Place of Trade Description            | Shows the market in which a trade transaction has been executed.   |
| Place of Trade Market Identifier Code | Shows the Identifier Code of the market in which a trade transaction has been executed.  |
| Place of Trade Code                   | Shows the Place of Trade information expressed as an ISO 20022 code from the possible values: <ul style="list-style-type: none"> <li><input type="checkbox"/> EXCH (for Stock Exchange)</li> <li><input type="checkbox"/> OTCO (for Over the Counter)</li> <li><input type="checkbox"/> PRIM (for Primary Market)</li> <li><input type="checkbox"/> SECM (for Secondary Market)</li> <li><input type="checkbox"/> VARI (for Various)</li> </ul> <p>Either this field or the proprietary identification of the place of trade in addition to the issuer and scheme name is available.</p> |

| Settlement Instruction     |   |
|----------------------------|---|
| Issuer Name                | Shows the entity that assigns the identification.   |
| Proprietary Identification | Shows the identification assigned by an institution.  |
| Schema Name                | Shows the name of the identification scheme.  |
| Other                      |   |
| Number of Days Accrued     | Shows the number of days on which the interest rate accrues.  |
| Original Ordered Amount    | Shows the original ordered amount.  |
| Original Ordered Currency  | Shows the currency of the original ordered amount.  |
| Market Client Side Code    | <p>Specifies if an instruction is for a market side or client side transaction:</p> <ul style="list-style-type: none"> <li><input type="checkbox"/> CLNT (for Client Side)</li> <li><input type="checkbox"/> MAKT (for Market Side)</li> </ul> <p>Either this field or the proprietary identification of the market client side in addition to the issuer and scheme name is available.</p> |
| Place of Clearing          | Shows the BIC code of the Clearing House involved in the settlement (if any).   |

## Buttons

|                          |   |
|--------------------------|---|
| Amendment Instruction    | <p>This function enables you to create a new amendment instruction of the selected settlement instruction.</p> <p>This button is not available in case any status of the settlement instruction does not allow the creation of the amendment instruction.</p> <p>Next screen:</p> <ul style="list-style-type: none"> <li><input type="checkbox"/> <i>Amendment securities instruction – new screen</i> [▶ 102]</li> </ul> |
| Hold/Release Instruction | <p>This function enables you to create a new hold/release/partial release instruction of the selected settlement instruction.</p> <p>This button is not available in case any status of the settlement instruction does not allow the creation of the hold/release/partial release instruction.</p> <p>Next screen:</p>   |

|                          | <input type="checkbox"/> <i>Hold/release instruction – new screen</i> [ ▶ 125]  |
|--------------------------|---|
| Cancellation Instruction | <p>This function enables you to create a new cancellation instruction of the selected settlement instruction.</p> <p>This button is not available in case any status of the settlement instruction does not allow the creation of the cancellation instruction.</p> <p>Next screen:</p> <p><i>Cancellation securities instruction – new screen</i> [ ▶ 116]</p>   |
| Revisions/Audit Trail    | <p>This function enables you to display the revisions of the selected settlement instruction.</p> <p>Next screen:</p> <input type="checkbox"/> <i>Revisions/audit trail – list screen</i> [ 661]  |
| Status History           | <p>This function enables you to display the status history of the selected settlement instruction.</p> <p>Next screen:</p> <input type="checkbox"/> <i>Status history – details screen</i> [ ▶ 266]   |
| Related Outbound Message | <p>This function enables you to display the outbound messages related to the settlement instruction.</p> <p>In case the instruction is linked to more than one outbound message, the <i>outbound messages - search/list</i> screen is displayed. In case the query only returns 1 valid message, the <i>outbound message – details</i> screen is displayed directly.</p> <p>Next screens:</p> <input type="checkbox"/> <i>Outbound messages – search/list screen</i> [ 645]<br><input type="checkbox"/> <i>Outbound message – details screen</i> [ ▶ 653] |
| Related Inbound Message  | <p>This function enables you to display the inbound message related to the settlement instruction.</p> <p>Next screens:</p> <input type="checkbox"/> <i>Inbound messages – search/list screen</i> [ ▶ 628]<br><input type="checkbox"/> <i>Inbound message – details screen</i> [ ▶ 635]   |
| Copy Instruction         | <p>This function enables you to copy fields to create a new settlement instruction with the same attributes.</p> <p>Next screen:</p> <input type="checkbox"/> <i>Settlement instruction – new screen</i> [ ▶ 210]   |



|                      |  |
|----------------------|--|
| Associated Penalties | <p>This function enables you to display the details of the possible penalty(ies) associated to the Settlement Instruction:</p> <ul style="list-style-type: none"><li><input type="checkbox"/> If there is only one result Penalty - details screen is displayed.</li><li><input type="checkbox"/> If there are more than one result Penalty – search/list - screen is displayed.</li></ul> <p>This function will not be available during the processing of penalties i.e. between the Events “PMSS” (Penalty Mechanism- Stop Screens and penalty modification requests) and “PMRR” (Penalty Mechanism- Restart GUI and Restart processing penalty modification requests).</p> <p>This function replicates the penalty query using as parameter the T2S Actor Reference or the T2S Reference of the underlying Settlement Instruction.</p> <p>This button shall be only visible for those having the privilege: “Penalty Query Privilege”. This privilege should be only granted to CSDs and the T2S Operator. To ensure it has not been granted by mistake to any other party, this button is only visible if the Party type of the User is “CSDY” or “TCSO”.</p> <p>Next screens:</p> <ul style="list-style-type: none"><li><input type="checkbox"/> Penalty – search/list screen</li><li><input type="checkbox"/> Penalty – details screen</li></ul> |
| Links                | <p>This function enables you to display all the links data preventing settlement at the moment when the request is performed.</p> <p>This button is not available in the following cases:</p> <ul style="list-style-type: none"><li><input type="checkbox"/> Cancellation Status = “cancelled”</li><li><input type="checkbox"/> Settlement Status = “settled”</li><li><input type="checkbox"/> Match Status = “Unmatched”</li></ul> <p>Next screen:</p> <ul style="list-style-type: none"><li><input type="checkbox"/> Links Preventing Settlement - screen [ ▶ 276]</li></ul>   |
| Matched Instruction  | <p>This function enables you to display the settlement instruction details of the matched business settlement instruction.</p>   |

|   |
|---|
|   |
| <p>This button is not available in case the instruction is unmatched or if the user doesn't have the 'Settlement Instruction Query' privilege on the securities account of the counterparty.</p> <p>Next screen:</p> <ul style="list-style-type: none"> <li><input type="checkbox"/> Settlement instruction – details screen</li> </ul> |

## 2.2.2.19 Settlement Instruction - New Screen

### Context of Usage

This screen contains a number of fields regarding settlement instructions. You can enter new data. Afterwards you can proceed further by clicking on the buttons below.

The screen can be used either in 2-eyes mode or 4-eyes mode.

This screen is not relevant for CB users.

Any schema validation error will be reported back to you for correction prior being able to leave the screen for further processing.

Alternatively you may cancel the action of entering the settlement instruction and leave the screen without clicking on the submit button.

### Screen Access

- Securities >> Settlement >> Settlement Instruction >> *Settlement instructions – search/list* screen >> Click on *new* button
- Securities >> Settlement >> Settlement Instructions Allegements >> *Allegements instructions - search/list* screen >> Click on *search* button >> *Allegement instructions – search/list* screen >> Click on the *details* button >> *Allegement instruction – details* screen >> Click on the *new settlement instruction* button
- Securities >> Settlement >> Settlement Instruction >> *Settlement instructions – search/list* screen >> Click on *search* button >> *Settlement instructions – search/list* screen >> Select the relevant settlement instruction and click on the *details* button >> *Settlement instruction – details* screen >> Click on the *copy* button

### Privileges

To use this screen, you need the following privileges [▶ 898]:

- Send new settlement instruction/settlement restriction on securities either on a securities account or on behalf of an external CSD
- Send new instruction using a specific instructing party
- Send settlement Instruction with non-modifiable flag activated
- Link to an instruction / pool reference belonging to a specific party
- Use ISO transaction code AUTO (auto-collateralisation)

- Use ISO transaction code BYIY (buy-in)
- Use ISO transaction code BSBK (buy sell back)
- Use ISO transaction code CLAI (market claim)
- Use ISO transaction code CNCB (central bank collateral operation)
- Use ISO transaction code COLI (collateral in)
- Use ISO transaction code COLO (collateral out)
- Use ISO transaction code CONV (depository receipt conversion)
- Use ISO transaction code CORP (corporate action)
- Use ISO transaction code ETFT (exchange trade funds)
- Use ISO transaction code FCTA (factor update)
- Use ISO transaction code INSP (move of stock)
- Use ISO transaction code ISSU (issuance)
- Use ISO transaction code MKDW (mark down)
- Use ISO transaction code MKUP (mark up)
- Use ISO transaction code NETT (netting)
- Use ISO transaction code NSYN (non syndicated)
- Use ISO transaction code OWNE (external account transfer)
- Use ISO transaction code OWNI (internal account transfer)
- Use ISO transaction code PAIR (pair off)
- Use ISO transaction code PLAC (placement)
- Use ISO transaction code PORT (portfolio move)
- Use ISO transaction code REAL (realignment)
- Use ISO transaction code REDI (withdrawal)
- Use ISO transaction code REDM (redemption)
- Use ISO transaction code RELE (depository receipt release cancellation)
- Use ISO transaction code REPU (repo)
- Use ISO transaction code RODE (return delivery without matching)
- Use ISO transaction code RVPO (reverse repurchase agreement)
- Use ISO transaction code SBBK (sell buy back)
- Use ISO transaction code SBRE (borrowing reallocation)
- Use ISO transaction code SECB (securities borrowing)
- Use ISO transaction code SECL (securities lending)
- Use ISO transaction code SLRE (lending reallocation)

- Use ISO transaction code SUBS (subscription)
- Use ISO transaction code SWIF (switch from)
- Use ISO transaction code SWIT (switch to)
- Use ISO transaction code SYND (syndicate underwriters)
- Use ISO transaction code TBAC (TBA closing)
- Use ISO transaction code TRAD (trade)
- Use ISO transaction code TRPO (triparty repo)
- Use ISO transaction code TRVO (triparty reverse repo)
- Use ISO transaction code TURN (turnaround)
- Party hold settlement instruction on a securities account or on behalf of an external CSD
- CSD hold settlement instruction either on a securities account or on behalf of the CSD in T2S

## References

### User Instructions Part

This screen is part of the following business scenarios:

- Copy a settlement instruction [[▶ 690](#)]
- Enter a settlement instruction [[▶ 686](#)]
- Respond to an allegation instruction [[▶ 696](#)]

### Business Functionality Document

This screen corresponds to the following business function:

- Add settlement instruction or settlement restriction (T2S.GUI.SESE.INX.0070)

Screenshot

Illustration 58: Settlement instruction - new screen

Field Description

| General                        |  |
|--------------------------------|--|
| Securities Movement Type Code* | Select if the movement on the securities account results from a deliver or a receiver instruction from one of the possible values:<br><br><input type="checkbox"/> DELI<br><input type="checkbox"/> RECE |

| General                           |   |
|-----------------------------------|---|
|                                   | <p>References for error messages: [▶ 1054]</p> <ul style="list-style-type: none"> <li><input type="checkbox"/> MVCV237</li> <li><input type="checkbox"/> MVCV243</li> <li><input type="checkbox"/> MVCV248</li> <li><input type="checkbox"/> MVCV253</li> <li><input type="checkbox"/> MVCV271</li> <li><input type="checkbox"/> MVCV272</li> <li><input type="checkbox"/> MVCV279</li> <li><input type="checkbox"/> MVCV280</li> <li><input type="checkbox"/> MVCV281</li> <li><input type="checkbox"/> MVCV282</li> <li><input type="checkbox"/> MVCV287</li> <li><input type="checkbox"/> MVCV288</li> <li><input type="checkbox"/> MVCV298</li> <li><input type="checkbox"/> MVCV299</li> <li><input type="checkbox"/> MVCV305</li> <li><input type="checkbox"/> MVRR929</li> <li><input type="checkbox"/> MVRR941</li> <li><input type="checkbox"/> MVIC315</li> <li><input type="checkbox"/> MVIC316</li> <li><input type="checkbox"/> MVIC317</li> <li><input type="checkbox"/> MVIC318</li> </ul> |
| <p>Securities Account Number*</p> | <p>You can choose to either enter the securities account number or to select it from the suggested items in the drop-down menu.</p> <p>Required format is: max. 35 characters (SWIFT-x)</p> <p>References for error messages: [▶ 1054]</p> <ul style="list-style-type: none"> <li><input type="checkbox"/> MVCP009</li> <li><input type="checkbox"/> MVCP010</li> <li><input type="checkbox"/> MVCP036</li> <li><input type="checkbox"/> MVCP037</li> <li><input type="checkbox"/> MVCP044</li> </ul>   |

| General                      |   |
|------------------------------|---|
|                              | <input type="checkbox"/> MVCV271<br><input type="checkbox"/> MVCV272<br><input type="checkbox"/> MVCV273<br><input type="checkbox"/> MVCV274<br><input type="checkbox"/> MVCV275<br><input type="checkbox"/> MVCV276<br><input type="checkbox"/> MVCV277<br><input type="checkbox"/> MVCV278<br><input type="checkbox"/> MVCV279<br><input type="checkbox"/> MVCV280<br><input type="checkbox"/> MVCV281<br><input type="checkbox"/> MVCV282<br><input type="checkbox"/> MVCV305<br><input type="checkbox"/> MVCA509<br><input type="checkbox"/> MVCA510<br><input type="checkbox"/> MVCA511<br><input type="checkbox"/> MVR944<br><input type="checkbox"/> MVIC315<br><input type="checkbox"/> MVIC317<br><input type="checkbox"/> MVIC318<br><input type="checkbox"/> MVIC319<br><input type="checkbox"/> MVIC320 |
| Securities Account Owner BIC | Enter the BIC of the securities account owner.<br>Required format is: max. 11 characters (SWIFT-x)<br>References for error messages: [▶ 1054]<br><input type="checkbox"/> MVCV243<br><input type="checkbox"/> MVCV253<br><input type="checkbox"/> MVCV279<br><input type="checkbox"/> MVCV281<br>If the 'Securities Movement Type Code' is set to 'RECE', and both the 'Securities Account Owner BIC' field and the 'Receiving CSD Participant – Party BIC' field are filled in, they must be the same. If the Securities Movement Type   |

| General               |  |
|-----------------------|--|
|                       | Code is set to DELI and both the 'Securities Account Owner BIC' field and the 'Delivering CSD Participant – Party BIC' field are filled in, they must be the same.   |
| ISIN*                 | Select the ISIN of the security from the drop-down menu.<br>References for error messages: [▶ 1054]<br><input type="checkbox"/> MVCV205<br><input type="checkbox"/> MVCV298<br><input type="checkbox"/> MVCV299<br><input type="checkbox"/> MVCV301<br><input type="checkbox"/> MVCV303<br><input type="checkbox"/> MVIC305<br><input type="checkbox"/> MVIC307<br><input type="checkbox"/> MVIC308<br><input type="checkbox"/> MVIC309<br><input type="checkbox"/> MVIC311<br><input type="checkbox"/> MVIC313<br><input type="checkbox"/> MVIC315<br><input type="checkbox"/> MVIC316<br><input type="checkbox"/> MVIC317<br><input type="checkbox"/> MVIC318<br><input type="checkbox"/> MVIC319<br><input type="checkbox"/> MVIC320<br><input type="checkbox"/> MVSQ602<br><input type="checkbox"/> MVSQ604<br><input type="checkbox"/> MVSQ606<br><input type="checkbox"/> MVR945 |
| Securities Short Name | Shows the description of the selected ISIN.<br>This field is automatically filled in when you have entered an ISIN in the 'ISIN' field.  |
| Settlement Quantity*  | Enter the quantity stated in the settlement instruction.<br>Required format is:<br>For settlement type = Unit, max. 15 digit(s) incl. decimal point (thereof max. 14 decimal places)   |



| General           |  |
|-------------------|--|
|                   | <p>For settlement type = Face Amount, max. 15 digit(s) incl. decimal point (thereof max. 5 decimal places)</p> <p>References for error messages: [▶ 1054]</p> <ul style="list-style-type: none"><li><input type="checkbox"/> MVCV286</li><li><input type="checkbox"/> MVSQ602</li><li><input type="checkbox"/> MVSQ604</li><li><input type="checkbox"/> MVSQ606</li><li><input type="checkbox"/> MVSQ610</li><li><input type="checkbox"/> MVSQ612</li></ul> <p>In case there is no exchange of securities the value must be set to zero (i.e. for a PFOD the value needs to be set to '0' value).</p>                      |
| Settlement Type*  | <p>Select the type of settlement foreseen for the securities from the possible values:</p> <ul style="list-style-type: none"><li><input type="checkbox"/> Units</li><li><input type="checkbox"/> Face Amount</li></ul> <p>References for error messages: [▶ 1054]</p> <ul style="list-style-type: none"><li><input type="checkbox"/> MVCV286</li><li><input type="checkbox"/> MVSQ604</li><li><input type="checkbox"/> MVSQ612</li></ul> <p>This field is automatically filled in when an ISIN is chosen.</p>  |
| Payment Type Code | <p>Select how the transaction is to be settled, against payment or free of payment from the possible values:</p> <ul style="list-style-type: none"><li><input type="checkbox"/> APMT</li><li><input type="checkbox"/> FREE</li></ul> <p>References for error messages: [▶ 1054]</p> <ul style="list-style-type: none"><li><input type="checkbox"/> MVCU103</li><li><input type="checkbox"/> MVCU107</li><li><input type="checkbox"/> MVCA105</li><li><input type="checkbox"/> MVCA503</li><li><input type="checkbox"/> MVCA505</li><li><input type="checkbox"/> MVCA507</li><li><input type="checkbox"/> MVCA511</li></ul> |

| General                           |   |
|-----------------------------------|---|
|                                   | <ul style="list-style-type: none"> <li><input type="checkbox"/> MVCA517</li> <li><input type="checkbox"/> MVCA518</li> <li><input type="checkbox"/> MVSD403</li> <li><input type="checkbox"/> MVSD406</li> <li><input type="checkbox"/> MVRR941</li> <li><input type="checkbox"/> MVRR942</li> </ul> <p>If the 'Payment Type Code' field is set to 'APMT', the 'Debit Credit Indicator' field must be filled in too.</p> <p>If the payment type code is set from 'APMT' to 'FREE', the fields 'Debit Credit Indicator', 'Currency' and 'Settlement Amount' become optional. Additionally, in case any data has been previously filled in any of these fields, it will be automatically removed upon the update of the payment type code from 'APMT' to 'FREE'. After the automatic deletion of the data, the fields can be filled in again.</p> |
| Debit Credit Indicator            | <p>Select the relevant value when the original settlement amount has a value from the possible values:</p> <ul style="list-style-type: none"> <li><input type="checkbox"/> CRDT</li> <li><input type="checkbox"/> DBIT</li> </ul> <p>References for error messages: [▶ 1054]</p> <ul style="list-style-type: none"> <li><input type="checkbox"/> MVCV256</li> <li><input type="checkbox"/> MVCV257</li> <li><input type="checkbox"/> MVCA517</li> <li><input type="checkbox"/> MVCA518</li> <li><input type="checkbox"/> MVCA519</li> </ul> <p>In case the Payment Type Code is set to 'APMT' or the 'Settlement Amount' field is filled, the field Debit Credit indicator becomes mandatory.</p> <p>If the 'Debit Credit Indicator' field is filled, the 'Settlement Amount' field must be filled in too (and vice versa).</p>                 |
| T2S Dedicated Cash Account Number | <p>Enter the dedicated cash account number.</p> <p>In case the T2S dedicated cash account number is not filled in, T2S uses the default DCA stored in reference data for the relevant securities account and currency defined in the settlement instruction.</p>  |

| General           |   |
|-------------------|---|
|                   | <p>Required format is: max. 34 characters (SWIFT-x)</p> <p>References for error messages: [▶ 1054]</p> <ul style="list-style-type: none"><li><input type="checkbox"/> MCV256</li><li><input type="checkbox"/> MCV257</li><li><input type="checkbox"/> MVCA105</li><li><input type="checkbox"/> MVCA501</li><li><input type="checkbox"/> MVCA502</li><li><input type="checkbox"/> MVCA503</li><li><input type="checkbox"/> MVCA505</li><li><input type="checkbox"/> MVCA506</li><li><input type="checkbox"/> MVCA507</li><li><input type="checkbox"/> MVCA509</li><li><input type="checkbox"/> MVCA510</li><li><input type="checkbox"/> MVCA511</li><li><input type="checkbox"/> MVCA514</li><li><input type="checkbox"/> MVCA515</li><li><input type="checkbox"/> MVCA516</li><li><input type="checkbox"/> MVCA517</li><li><input type="checkbox"/> MVCA518</li><li><input type="checkbox"/> MVCA519</li><li><input type="checkbox"/> MVRR947</li></ul> <p>In case the payment type Code is set to 'APMT', and either the debtor cash account, if the instruction debits cash, or, the creditor cash account, if the instruction credits cash, is present, the dedicated cash account number becomes mandatory.</p> |
| Settlement Amount | <p>Enter the amount to be settled.</p> <p>Required format is: max. 15 digit(s)incl. decimal point (thereof max. 5 decimal places)</p> <p>References for error messages: [▶ 1054]</p> <ul style="list-style-type: none"><li><input type="checkbox"/> MVCU107</li><li><input type="checkbox"/> MCV286</li><li><input type="checkbox"/> MVCA514</li></ul>  |

| General           |   |
|-------------------|---|
|                   | <ul style="list-style-type: none"> <li><input type="checkbox"/> MVCA515</li> <li><input type="checkbox"/> MVCA516</li> <li><input type="checkbox"/> MVSD403</li> </ul> <p>In case the Payment Type Code is set to 'APMT' or the 'Debit Credit Indicator' field is filled, the Settlement Amount becomes mandatory.</p> <p>If this field is filled, the 'Debit Credit Indicator' and 'Currency' fields must be filled in too (and vice versa).</p>   |
| Currency          | <p>Select the currency of the settlement instruction from the drop-down menu.</p> <p>This field needs to be filled in if the 'T2S Dedicated Cash Account Number' field is filled in.</p> <p>This field becomes mandatory when the 'Settlement Amount' field has been filled in.</p> <p>References for error messages: [▶ 1054]</p> <ul style="list-style-type: none"> <li><input type="checkbox"/> MVCA105</li> <li><input type="checkbox"/> MVCU101</li> <li><input type="checkbox"/> MVCU103</li> <li><input type="checkbox"/> MVCU107</li> <li><input type="checkbox"/> MVCA514</li> <li><input type="checkbox"/> MVCA515</li> <li><input type="checkbox"/> MVCA516</li> </ul> <p>If this field is filled, the 'Settlement Amount' field becomes mandatory (and vice versa).</p> |
| Party Hold Status | <p>Select a hold status as set by the T2S party from the possible values:</p> <ul style="list-style-type: none"> <li><input type="checkbox"/> Empty (default value)</li> <li><input type="checkbox"/> PTYH: only the instructed leg is put on Party Hold</li> <li><input type="checkbox"/> PRCY: only the T2S generated counterleg is put on Party Hold</li> <li><input type="checkbox"/> BOTH: both legs are put on Party Hold</li> <li><input type="checkbox"/> Released: No hold apply in both legs</li> </ul> <p>References for error messages: [▶ 1054]</p> <ul style="list-style-type: none"> <li><input type="checkbox"/> MVCP036</li> </ul>   |

| General                      |   |
|------------------------------|---|
|                              | <ul style="list-style-type: none"><li><input type="checkbox"/> MVCP092</li><li><input type="checkbox"/> MVCP124</li><li><input type="checkbox"/> MVCP125</li></ul> <p>The values selected for the 'Party Hold Status' and 'CSD Hold Status' must be consistent with each other. If one of them is set to 'On Hold', the other one can only be set to 'On Hold' or left empty, but it can never be set to 'Released' and vice versa.</p>   |
| Party Hold Reason            | <p>Enter the additional reason information of the Party Hold Status.</p> <p>Required format is: max. 210 characters</p> <p>This field is greyed out in case the 'Party Hold Status' is left empty.</p>  |
| CSD Hold Status              | <p>Select a hold status as set by the CSD from the possible values:</p> <ul style="list-style-type: none"><li><input type="checkbox"/> Empty (default value)</li><li><input type="checkbox"/> On Hold</li><li><input type="checkbox"/> Released</li></ul> <p>References for error messages: [▶ 1054]</p> <ul style="list-style-type: none"><li><input type="checkbox"/> MVCP037</li><li><input type="checkbox"/> MVCP038</li><li><input type="checkbox"/> MVCP126</li><li><input type="checkbox"/> MVCP127</li></ul> <p>The values selected for the 'Party Hold Status' and 'CSD Hold Status' must be consistent with each other. If one of them is set to 'On Hold', the other one can only be set to 'On Hold' or left empty, but it can never be set to 'Released' and vice versa.</p> |
| CSD Hold Reason              | <p>Enter the additional reason information of the CSD Hold Status.</p> <p>Required format is: max. 210 characters</p> <p>This field is greyed out in case the 'CSD Hold Status' is left empty.</p>  |
| Partial Settlement Indicator | <p>Select to allow partial settlement from the possible values:</p> <ul style="list-style-type: none"><li><input type="checkbox"/> Empty (default value)</li></ul>  |

| General                      |   |
|------------------------------|---|
|                              | <ul style="list-style-type: none"><li><input type="checkbox"/> Partial not allowed</li><li><input type="checkbox"/> Partial settlement cash threshold allowed</li><li><input type="checkbox"/> Partial settlement quantity threshold allowed</li><li><input type="checkbox"/> Partial allowed</li></ul>   |
| Transaction Identification*  | <p>Enter an identification to unambiguously identify the instruction.</p> <p>Required format is: max. 16 characters (SWIFT-x-red)</p> <p>References for error messages: [▶ 1054]</p> <ul style="list-style-type: none"><li><input type="checkbox"/> MVDC002</li><li><input type="checkbox"/> MVDC004</li><li><input type="checkbox"/> MVDC006</li><li><input type="checkbox"/> MVDC014</li><li><input type="checkbox"/> MVDC016</li><li><input type="checkbox"/> MVDC018</li><li><input type="checkbox"/> MVDC020</li><li><input type="checkbox"/> MVDC021</li><li><input type="checkbox"/> MVSR701</li><li><input type="checkbox"/> MVSR702</li><li><input type="checkbox"/> MVSR703</li><li><input type="checkbox"/> MVSR704</li><li><input type="checkbox"/> MVSR707</li></ul> |
| Instructing Party Parent BIC | <p>Select the parent BIC of the instructing party from the drop-down menu or search via the <i>magnifier</i> icon.</p> <p>Required format is: max. 11 characters (SWIFT-x)</p> <p>References for error messages: [▶ 1054]</p> <ul style="list-style-type: none"><li><input type="checkbox"/> MCVV229</li><li><input type="checkbox"/> MVCP119</li><li><input type="checkbox"/> MVDC024</li><li><input type="checkbox"/> MCVV106</li><li><input type="checkbox"/> MCVV287</li><li><input type="checkbox"/> MCVV288</li><li><input type="checkbox"/> MCVV289</li></ul>  |

| General               |   |
|-----------------------|---|
|                       | <ul style="list-style-type: none"> <li><input type="checkbox"/> MVDC002</li> <li><input type="checkbox"/> MVDC004</li> <li><input type="checkbox"/> MVDC006</li> <li><input type="checkbox"/> MVDC014</li> <li><input type="checkbox"/> MVDC016</li> <li><input type="checkbox"/> MVDC018</li> <li><input type="checkbox"/> MVDC021</li> <li><input type="checkbox"/> MVIC309</li> <li><input type="checkbox"/> MVIC313</li> <li><input type="checkbox"/> MVLI868</li> </ul> <p>In case the Instructing Party BIC is not entered, the Instructing Party BIC considered will be the party you belong to. If the Instructing Party Parent BIC is filled in, the Instructing Party BIC has to be filled in too.</p>  |
| Instructing Party BIC | <p>Select the BIC of the instructing party via from the drop-down menu or search the <i>magnifier</i> icon.</p> <p>Required format is: max. 11 characters (SWIFT-x)</p> <p>References for error messages: [▶ 1054]</p> <ul style="list-style-type: none"> <li><input type="checkbox"/> MVCV229</li> <li><input type="checkbox"/> MVCP119</li> <li><input type="checkbox"/> MVDC024</li> <li><input type="checkbox"/> MVCV106</li> <li><input type="checkbox"/> MVCV287</li> <li><input type="checkbox"/> MVCV288</li> <li><input type="checkbox"/> MVCV289</li> <li><input type="checkbox"/> MVDC002</li> <li><input type="checkbox"/> MVDC004</li> <li><input type="checkbox"/> MVDC006</li> <li><input type="checkbox"/> MVDC014</li> <li><input type="checkbox"/> MVDC016</li> <li><input type="checkbox"/> MVDC018</li> <li><input type="checkbox"/> MVDC021</li> <li><input type="checkbox"/> MVIC309</li> </ul> |

| General                   |  |
|---------------------------|--|
|                           | <input type="checkbox"/> MVIC313<br><input type="checkbox"/> MVLI868<br><p>In case the Instructing Party BIC is not entered, the Instructing Party BIC considered will be the party you belong to. If the Instructing Party BIC is filled in, the Instructing Party Parent BIC has to be filled in too.</p>  |
| Intended Settlement Date* | <p>Enter the date from which the instruction becomes eligible to be submitted to settlement or use the <i>calendar</i> icon.</p> <p>Required format is: YYYY-MM-DD</p> <p>References for error messages: [▶ 1054]</p> <input type="checkbox"/> MVCV106<br><input type="checkbox"/> MVCV229<br><input type="checkbox"/> MVCV234<br><input type="checkbox"/> MVCV235<br><input type="checkbox"/> MVCV241<br><input type="checkbox"/> MVCV242<br><input type="checkbox"/> MVCV245<br><input type="checkbox"/> MVCV246<br><input type="checkbox"/> MVCV251<br><input type="checkbox"/> MVCV252<br><input type="checkbox"/> MVCV273<br><input type="checkbox"/> MVCV274<br><input type="checkbox"/> MVCV275<br><input type="checkbox"/> MVCV301<br><input type="checkbox"/> MVCV303<br><input type="checkbox"/> MVCA505<br><input type="checkbox"/> MVCA506<br><input type="checkbox"/> MVCA507<br><input type="checkbox"/> MVCA509<br><input type="checkbox"/> MVCA510<br><input type="checkbox"/> MVCA511<br><input type="checkbox"/> MVIC305<br><input type="checkbox"/> MVSD401 |



| General     |  |
|-------------|--|
|             | <input type="checkbox"/> MVSD403<br><input type="checkbox"/> MVSD406<br><input type="checkbox"/> MVSD411<br><input type="checkbox"/> MVSD412<br><input type="checkbox"/> MVLI813<br><input type="checkbox"/> MVLI814<br><input type="checkbox"/> MVLI815<br><input type="checkbox"/> MVLI816<br><input type="checkbox"/> MVLI817<br><input type="checkbox"/> MVLI818<br><input type="checkbox"/> MVLI831<br><input type="checkbox"/> MVLI832<br><input type="checkbox"/> MVLI833<br><input type="checkbox"/> MVRR957<br><input type="checkbox"/> MVRR960<br><input type="checkbox"/> MVCA517<br><input type="checkbox"/> MVCA518<br><input type="checkbox"/> MCVV120<br><input type="checkbox"/> MCVV121<br><input type="checkbox"/> MCVV123<br><input type="checkbox"/> MVIC307<br><input type="checkbox"/> MVIC308<br><input type="checkbox"/> MVIC311<br><input type="checkbox"/> MVIC315<br><input type="checkbox"/> MVIC316<br><input type="checkbox"/> MVIC317<br><input type="checkbox"/> MVIC318<br><input type="checkbox"/> MVIC319<br><input type="checkbox"/> MVIC320 |
| Trade Date* | Enter the date when the contract was made or use the <i>calendar</i> icon.<br><br>Required format is: YYYY-MM-DD   |

| General             |  |
|---------------------|--|
|                     | References for error messages: [ ▶ 1054]<br><input type="checkbox"/> MVSD401   |
| Externally Matched* | Select if the settlement instruction is externally matched from the possible values:<br><input type="checkbox"/> Yes<br><input type="checkbox"/> No (default value)<br>References for error messages: [ ▶ 1054]<br><input type="checkbox"/> MVCP010<br><input type="checkbox"/> MCV275<br><input type="checkbox"/> MCV278<br><input type="checkbox"/> MCV283<br><input type="checkbox"/> MCV003<br><input type="checkbox"/> MCV289<br><input type="checkbox"/> MVCA501<br><input type="checkbox"/> MVCA502<br><input type="checkbox"/> MVCA503<br><input type="checkbox"/> MVCA505<br><input type="checkbox"/> MVCA506<br><input type="checkbox"/> MVCA105<br><input type="checkbox"/> MVCA507<br><input type="checkbox"/> MVCA509<br><input type="checkbox"/> MVCA510<br><input type="checkbox"/> MVCA511<br><input type="checkbox"/> MVCA514<br><input type="checkbox"/> MVCA515<br><input type="checkbox"/> MVCA516<br><input type="checkbox"/> MVCP110<br><input type="checkbox"/> MVCP124<br><input type="checkbox"/> MVCP125<br><input type="checkbox"/> MVCP126<br><input type="checkbox"/> MVCP127<br><input type="checkbox"/> MVIC319 |

| General                  |   |
|--------------------------|---|
|                          | <input type="checkbox"/> MVIC316<br><input type="checkbox"/> MVIC320  |
| Receiving Depository BIC | <p>Enter the BIC of the receiving depository.<br/>Required format is: max. 11 characters (SWIFT-x)<br/>References for error messages: [▶ 1054]</p> <input type="checkbox"/> MVCP011<br><input type="checkbox"/> MVCP038<br><input type="checkbox"/> MCVV006<br><input type="checkbox"/> MCVV245<br><input type="checkbox"/> MCVV246<br><input type="checkbox"/> MCVV247<br><input type="checkbox"/> MCVV248<br><input type="checkbox"/> MCVV249<br><input type="checkbox"/> MCVV250<br><input type="checkbox"/> MCVV251<br><input type="checkbox"/> MCVV252<br><input type="checkbox"/> MCVV274<br><input type="checkbox"/> MCVV277<br><input type="checkbox"/> MCVV281<br><input type="checkbox"/> MCVV282<br><input type="checkbox"/> MCVV002<br><input type="checkbox"/> MVIC305<br><input type="checkbox"/> MVIC307<br><input type="checkbox"/> MVIC308<br><input type="checkbox"/> MCVV283<br><input type="checkbox"/> MCVV288<br><input type="checkbox"/> MCVV289<br><input type="checkbox"/> MCVV299<br><input type="checkbox"/> MVIC316<br><input type="checkbox"/> MVCP127<br><input type="checkbox"/> MVCP103<br><input type="checkbox"/> MCVV003 |

| General                   |  |
|---------------------------|--|
|                           | <ul style="list-style-type: none"> <li><input type="checkbox"/> MVCV122</li> <li><input type="checkbox"/> MVCV283</li> <li><input type="checkbox"/> MVCV288</li> <li><input type="checkbox"/> MVCV289</li> <li><input type="checkbox"/> MVCV299</li> <li><input type="checkbox"/> MVCV278</li> <li><input type="checkbox"/> MVIC315</li> </ul> <p>The field 'Receiving Depository BIC' becomes mandatory if:</p> <ul style="list-style-type: none"> <li><input type="checkbox"/> The 'Securities Movement Type Code' is set to 'DELI'.</li> <li><input type="checkbox"/> The 'Securities Movement Type Code' is set to 'RECE' and the settlement instruction is already matched cross-CSD</li> </ul>   |
| Receiving CSD Participant |  |
| Party BIC                 | <p>Enter the BIC of the receiving CSD participant.<br/>Required format is: max. 11 characters (SWIFT-x)<br/>References for error messages: [▶ 1054]</p> <ul style="list-style-type: none"> <li><input type="checkbox"/> MVCV005</li> <li><input type="checkbox"/> MVCV248</li> <li><input type="checkbox"/> MVCV249</li> <li><input type="checkbox"/> MVCV250</li> <li><input type="checkbox"/> MVCV251</li> <li><input type="checkbox"/> MVCV252</li> <li><input type="checkbox"/> MVCV253</li> <li><input type="checkbox"/> MVCV282</li> <li><input type="checkbox"/> MVCV283</li> <li><input type="checkbox"/> MVCV122</li> </ul> <p>In case the 'Securities Movement Type Code' is set to 'DELI', the 'Receiving CSD participant – Party BIC' field becomes mandatory.</p> <p>If the Securities Movement Type Code is set to 'RECE', and the settlement instruction is already matched cross-CSD, the 'Receiving CSD participant – Party BIC' field becomes mandatory.</p> |

| General  |   |
|--|---|
|  | <p>If the Securities Movement Type Code is set to RECE, and both the 'Securities Account Owner BIC' field and the 'Receiving CSD Participant – Party BIC' field are filled in, they must be the same.</p> <p>If the 'Receiving CSD Participant BIC' field is present, the 'Receiving Depository BIC' field must be present.</p>   |
| Securities Account                             | <p>Enter the securities account of the receiving CSD participant.</p> <p>Required format is: max. 35 characters (SWIFT-x)</p> <p>References for error messages: [▶ 1054]</p> <ul style="list-style-type: none"> <li><input type="checkbox"/> MVCV282</li> <li><input type="checkbox"/> MVCP124</li> <li><input type="checkbox"/> MVCP125</li> <li><input type="checkbox"/> MVCP126</li> <li><input type="checkbox"/> MVCP044</li> <li><input type="checkbox"/> MVCV002</li> <li><input type="checkbox"/> MVCV003</li> <li><input type="checkbox"/> MVCV274</li> <li><input type="checkbox"/> MVCV275</li> <li><input type="checkbox"/> MVCV277</li> <li><input type="checkbox"/> MVCV281</li> <li><input type="checkbox"/> MVIC320</li> </ul> <p>This field becomes mandatory in case the settlement instruction is already matched and is delivering securities.</p> |
| Processing Identification                      | <p>Enter the reference of the instruction assigned by the receiving CSD participant.</p> <p>Required format is: max. 16 characters (SWIFT-x-red)</p>  |
| <b>Client of the Receiving CSD Participant</b> |   |
| Party BIC                                      | <p>Enter BIC of the client of the receiving CSD participant.</p> <p>Required format is: max. 11 characters (SWIFT-x)</p> <p>Only one of the following party identifications can be filled in for a given settlement party: 'Party BIC', 'Name' or the combination of 'Identification', 'Issuer' and optionally 'Schema Name'.</p>   |

| General            |  |
|--------------------|--|
|                    | <p>References for error messages: [ ▶ 1054]</p> <ul style="list-style-type: none"> <li><input type="checkbox"/> MVCV254</li> <li><input type="checkbox"/> MVCV123</li> </ul> <p>If the 'Client of the Receiving CSD Participant – Party BIC' field is present the 'Receiving CSD Participant - Party BIC' field must be present.</p>                                     |
| Name               | <p>Enter the name and address of the client of the receiving CSD participant.</p> <p>Required format is: max. 140 characters (SWIFT-x)</p> <p>Only one of the following party identifications can be filled in for a given settlement party: 'Party BIC', 'Name' or the combination of 'Identification', 'Issuer' and optionally 'Schema Name'.</p>                      |
| Identification     | <p>Enter the proprietary information, often a code, of the client of the receiving CSD participant.</p> <p>Required format is: max. 34 characters (SWIFT-x)</p> <p>Only one of the following party identifications can be filled in for a given settlement party: 'Party BIC', 'Name' or the combination of 'Identification', 'Issuer' and optionally 'Schema Name'.</p> |
| Issuer             | <p>Enter the issuer identification of the client of the receiving CSD participant.</p> <p>Required format is: max. 4 characters (SWIFT-x)</p> <p>Only one of the following party identifications can be filled in for a given settlement party: 'Party BIC', 'Name' or the combination of 'Identification', 'Issuer' and optionally 'Schema Name'.</p>                   |
| Schema Name        | <p>Enter a short textual description of the schema of the client of the receiving CSD participant.</p> <p>Required format is: max. 4 characters (SWIFT-x)</p> <p>Only one of the following party identifications can be filled in for a given settlement party: 'Party BIC', 'Name' or the combination of 'Identification', 'Issuer' and optionally 'Schema Name'.</p>   |
| Securities Account | <p>Enter the securities account of the client of the receiving CSD participant.</p>  |

| General                   |  |
|---------------------------|--|
|                           | <p>Required format is: max. 35 characters (SWIFT-x)</p> <p>References for error messages: [▶ 1054]</p> <ul style="list-style-type: none"><li><input type="checkbox"/> MVCP044</li><li><input type="checkbox"/> MVCV271</li><li><input type="checkbox"/> MVCV273</li><li><input type="checkbox"/> MVCV275</li><li><input type="checkbox"/> MVCV276</li><li><input type="checkbox"/> MVCV280</li><li><input type="checkbox"/> MVCV001</li></ul> <p>This field becomes mandatory in case the settlement instruction is already matched and is delivering securities.</p> <p>If the 'Client of the Receiving CSD Participant - Securities Account' field is present, one of the party identifiers for the client of the receiving CSD participant becomes mandatory.</p>   |
| Delivering Depository BIC | <p>Enter the BIC of the delivering depository.</p> <p>Required format is: max. 11 characters (SWIFT-x)</p> <p>References for error messages: [▶ 1054]</p> <ul style="list-style-type: none"><li><input type="checkbox"/> MVCP011</li><li><input type="checkbox"/> MVCP038</li><li><input type="checkbox"/> MVCV008</li><li><input type="checkbox"/> MVCV234</li><li><input type="checkbox"/> MVCV235</li><li><input type="checkbox"/> MVCV236</li><li><input type="checkbox"/> MVCV237</li><li><input type="checkbox"/> MVCV238</li><li><input type="checkbox"/> MVCV239</li><li><input type="checkbox"/> MVCV241</li><li><input type="checkbox"/> MVCV242</li><li><input type="checkbox"/> MVCV273</li><li><input type="checkbox"/> MVCV276</li><li><input type="checkbox"/> MVCV278</li><li><input type="checkbox"/> MVCV279</li></ul> |

| General                    |   |
|----------------------------|---|
|                            | <ul style="list-style-type: none"> <li><input type="checkbox"/> MVCV280</li> <li><input type="checkbox"/> MVCV001</li> <li><input type="checkbox"/> MVIC305</li> <li><input type="checkbox"/> MVIC307</li> <li><input type="checkbox"/> MVIC308</li> <li><input type="checkbox"/> MVCP102</li> <li><input type="checkbox"/> MVCV120</li> <li><input type="checkbox"/> MVCV298</li> <li><input type="checkbox"/> MVCV003</li> <li><input type="checkbox"/> MVCV283</li> <li><input type="checkbox"/> MVCV287</li> <li><input type="checkbox"/> MVCV289</li> <li><input type="checkbox"/> MVIC316</li> <li><input type="checkbox"/> MVCP127</li> </ul> <p>The field 'Delivering Depository BIC' becomes mandatory if:</p> <ul style="list-style-type: none"> <li><input type="checkbox"/> The 'Securities Movement Type Code' is set to 'RECE'.</li> <li><input type="checkbox"/> The 'Securities Movement Type Code' is set to 'DELI' and the settlement instruction is already matched cross-CSD</li> </ul> |
| Delivering CSD Participant |   |
| Party BIC                  | <p>Enter the BIC of the delivering CSD participant.</p> <p>Required format is: max. 11 characters (SWIFT-x)</p> <p>References for error messages: [▶ 1054]</p> <ul style="list-style-type: none"> <li><input type="checkbox"/> MVCV007</li> <li><input type="checkbox"/> MVCV244</li> <li><input type="checkbox"/> MVCV120</li> <li><input type="checkbox"/> MVCV121</li> <li><input type="checkbox"/> MVCV237</li> <li><input type="checkbox"/> MVCV238</li> <li><input type="checkbox"/> MVCV239</li> <li><input type="checkbox"/> MVCV241</li> <li><input type="checkbox"/> MVCV242</li> </ul>   |



| General            |  |
|--------------------|--|
|                    | <ul style="list-style-type: none"> <li><input type="checkbox"/> MVCV243</li> <li><input type="checkbox"/> MVCV280</li> <li><input type="checkbox"/> MVCV283</li> </ul> <p>In case the 'Securities Movement Type Code' is set to 'RECE', the 'Delivering CSD Participant – Party BIC' field becomes mandatory.</p> <p>If the Securities Movement Type Code is set to 'DELI', and the settlement instruction is already matched cross-CSD, the 'Delivering CSD participant – Party BIC' field becomes mandatory.</p> <p>If the 'Securities Movement Type Code' is set to 'DELI' and both the 'Securities Account Owner BIC' field and the 'Delivering CSD Participant – Party BIC' field are filled in, they must be the same.</p> <p>If the 'Delivering CSD Participant BIC' field is present, the 'Delivering Depository BIC' field must be present.</p> |
| Securities Account | <p>Enter the securities account of the delivering CSD participant.</p> <p>Required format is: max. 35 characters (SWIFT-x)</p> <p>References for error messages: [▶ 1054]</p> <ul style="list-style-type: none"> <li><input type="checkbox"/> MVCP044</li> <li><input type="checkbox"/> MVCV271</li> <li><input type="checkbox"/> MVCV273</li> <li><input type="checkbox"/> MVCV275</li> <li><input type="checkbox"/> MVCV276</li> <li><input type="checkbox"/> MVCV280</li> <li><input type="checkbox"/> MVCV001</li> <li><input type="checkbox"/> MVCV003</li> <li><input type="checkbox"/> MVCV272</li> <li><input type="checkbox"/> MVCV305</li> <li><input type="checkbox"/> MVCP124</li> <li><input type="checkbox"/> MVCP125</li> <li><input type="checkbox"/> MVCP126</li> <li><input type="checkbox"/> MVIC319</li> </ul>                       |

| General                                  |   |
|--|---|
|  | This field becomes mandatory in case the settlement instruction is already matched and is receiving securities.   |
| Processing Identification                | <p>Enter the reference of the instruction assigned by the delivering CSD participant.</p> <p>Required format is: max. 16 characters (SWIFT-x-red)</p> <p>References for error messages: [▶ 1054]</p> <p><input type="checkbox"/> MVCV244</p>  |
| Client of the Delivering CSD Participant |   |
| Party BIC                                | <p>Enter BIC of the client of the delivering CSD participant.</p> <p>Required format is: max. 11 characters (SWIFT-x)</p> <p>Only one of the following party identifications can be filled in for a given settlement party: 'Party BIC', 'Name' or the combination of 'Identification', 'Issuer' and optionally 'Schema Name'.</p> <p>References for error messages: [▶ 1054]</p> <p><input type="checkbox"/> MVCV244</p> <p>If the 'Client of the Delivering CSD Participant - Party BIC' field is present the 'Delivering CSD Participant – Party BIC' field must be present as well.</p> |
| Name                                     | <p>Enter the name and address of the client of the delivering CSD participant.</p> <p>Required format is: max. 140 characters (SWIFT-x)</p> <p>Only one of the following party identifications can be filled in for a given settlement party: 'Party BIC', 'Name' or the combination of 'Identification', 'Issuer' and optionally 'Schema Name'.</p>  |
| Identification                           | <p>Enter the proprietary information, often a code, of the client of the delivering CSD participant.</p> <p>Required format is: max. 34 characters (SWIFT-x)</p> <p>Only one of the following party identifications can be filled in for a given settlement party: 'Party BIC', 'Name' or the combination of 'Identification', 'Issuer' and optionally 'Schema Name'.</p>   |
| Issuer                                   | Enter the issuer identification of the client of the delivering CSD participant.  |

| General                   |   |
|---------------------------|---|
|                           | <p>Required format is: max. 4 characters (SWIFT-x)</p> <p>Only one of the following party identifications can be filled in for a given settlement party: 'Party BIC', 'Name' or the combination of 'Identification', 'Issuer' and optionally 'Schema Name'.</p>   |
| Schema Name               | <p>Enter a short textual description of the schema of the client of the delivering CSD participant.</p> <p>Required format is: max. 4 characters (SWIFT-x)</p> <p>Only one of the following party identifications can be filled in for a given settlement party: 'Party BIC', 'Name' or the combination of 'Identification', 'Issuer' and optionally 'Schema Name'.</p>   |
| Securities Account        | <p>Enter the securities account of the client of the delivering CSD participant.</p> <p>Required format is: max. 35 characters (SWIFT-x)</p> <p>If the 'Client of the Delivering CSD Participant - Securities Account' field is present, one of the party identifiers for the client of the delivering CSD participant becomes mandatory.</p>   |
| Detailed Information      |   |
| Priority*                 | <p>Select the level of priority from the possible values:</p> <ul style="list-style-type: none"> <li><input type="checkbox"/> Normal (default value)</li> <li><input type="checkbox"/> High</li> <li><input type="checkbox"/> Reserved</li> </ul> <p>References for error messages:</p> <ul style="list-style-type: none"> <li><input type="checkbox"/> MVSP208</li> </ul>  |
| Allowed Modification Flag | <p>Select, if the modification of the instruction by CSD participants is disallowed from the possible values:</p> <ul style="list-style-type: none"> <li><input type="checkbox"/> Empty (default value)</li> <li><input type="checkbox"/> TRUE: only the instructed leg can be modified / cancelled</li> <li><input type="checkbox"/> FALSE: <ul style="list-style-type: none"> <li><input type="checkbox"/> Already Matched SIs: the instructed leg cannot be modified / cancelled, but the T2S generated counter-leg can</li> </ul> </li> </ul> |

| General                               |   |
|---------------------------------------|---|
|                                       | <ul style="list-style-type: none"> <li><input type="checkbox"/> Unmatched SIs: the instructed leg cannot be modified / cancelled</li> <li><input type="checkbox"/> NONE: neither the instructed nor the T2S generated leg can be modified / cancelled</li> <li><input type="checkbox"/> BOTH: both legs can be modified / cancelled</li> </ul> <p>References for error messages: [▶ 1054]</p> <ul style="list-style-type: none"> <li><input type="checkbox"/> MVCP012</li> </ul>  |
| Corporate Action Event Identification | <p>Enter the identification of the corporate action event.</p> <p>Required format is: max. 16 characters (SWIFT-x-red)</p>  |
| Common Reference                      | <p>Enter the reference when the settlement instruction is already matched or in order to facilitate the matching within T2S.</p> <p>Required format is: max. 16 characters (SWIFT-x-red)</p>  |
| Beneficial Ownership                  | <p>Select, if there is a change of beneficial ownership:</p> <ul style="list-style-type: none"> <li><input type="checkbox"/> Empty (default value)</li> <li><input type="checkbox"/> Yes</li> <li><input type="checkbox"/> No</li> </ul>  |
| Repo Reference                        | <p>Enter the identification of a collateral transaction.</p> <p>Required format is: max. 16 characters (SWIFT-x-red)</p>  |
| Securities Transaction Type*          | <p>Select the type of transaction from the possible values:</p> <ul style="list-style-type: none"> <li><input type="checkbox"/> AUTO (for auto-collateralisation)</li> <li><input type="checkbox"/> BYIY (for buy-in)</li> <li><input type="checkbox"/> BSBK (for buy sell back)</li> <li><input type="checkbox"/> CLAI (for market claim)</li> <li><input type="checkbox"/> CNCB (for central bank collateral operation)</li> <li><input type="checkbox"/> COLI (for collateral in)</li> <li><input type="checkbox"/> COLO (for collateral out)</li> <li><input type="checkbox"/> CONV (for depository receipt conversion)</li> <li><input type="checkbox"/> CORP (for corporate action)</li> <li><input type="checkbox"/> FCTA (for factor update)</li> <li><input type="checkbox"/> INSP (for move of stock)</li> <li><input type="checkbox"/> ISSU (for depository receipt issue)</li> <li><input type="checkbox"/> MKDW (for mark down)</li> </ul> |

**General**

- MKUP (for mark up)
- NETT (for netting)
- NSYN (for non syndicated)
- OWNE (for external account transfer)
- OWNI (for internal account transfer)
- PAIR (for pair off)
- PLAC (for placement)
- PORT (for portfolio move)
- REAL (for realignment)
- REDI (for withdrawal)
- REDM (for redemption)
- RELE (for depository receipt release cancellation)
- REPU (for repo)
- RODE (for return delivery without matching)
- RVPO (for reverse repurchase agreement)
- SBBK (for sell buy back)
- SBRE (for borrowing reallocation)
- SECB (for securities borrowing)
- SECL (for securities lending)
- SLRE (for lending reallocation)
- SUBS (for subscription)
- SWIF (Switch From)
- SWIT (Switch To)
- SYND (for syndicate underwriters )
- TBAC (for TBA closing)
- TRAD (for trade)
- TRPO (for triparty repo)
- TRVO (for triparty reverse repo)
- ETFT (for exchange trade funds)
- TURN (for turnaround)

References for error messages: [▶ 1054]

- MVCP052

| General                  |         |
|--------------------------|---------|
| <input type="checkbox"/> | MVCP053 |
| <input type="checkbox"/> | MVCP054 |
| <input type="checkbox"/> | MVCP055 |
| <input type="checkbox"/> | MVCP056 |
| <input type="checkbox"/> | MVCP057 |
| <input type="checkbox"/> | MVCP058 |
| <input type="checkbox"/> | MVCP059 |
| <input type="checkbox"/> | MVCP060 |
| <input type="checkbox"/> | MVCP061 |
| <input type="checkbox"/> | MVCP062 |
| <input type="checkbox"/> | MVCP063 |
| <input type="checkbox"/> | MVCP064 |
| <input type="checkbox"/> | MVCP065 |
| <input type="checkbox"/> | MVCP066 |
| <input type="checkbox"/> | MVCP067 |
| <input type="checkbox"/> | MVCP068 |
| <input type="checkbox"/> | MVCP069 |
| <input type="checkbox"/> | MVCP070 |
| <input type="checkbox"/> | MVCP071 |
| <input type="checkbox"/> | MVCP072 |
| <input type="checkbox"/> | MVCP073 |
| <input type="checkbox"/> | MVCP074 |
| <input type="checkbox"/> | MVCP075 |
| <input type="checkbox"/> | MVCP076 |
| <input type="checkbox"/> | MVCP077 |
| <input type="checkbox"/> | MVCP078 |
| <input type="checkbox"/> | MVCP079 |
| <input type="checkbox"/> | MVCP080 |
| <input type="checkbox"/> | MVCP081 |
| <input type="checkbox"/> | MVCP082 |
| <input type="checkbox"/> | MVCP083 |
| <input type="checkbox"/> | MVCP084 |

| General                                    |   |
|--|---|
|  | <ul style="list-style-type: none"><li><input type="checkbox"/> MVCP085</li><li><input type="checkbox"/> MVCP086</li><li><input type="checkbox"/> MVCP087</li><li><input type="checkbox"/> MVCP088</li><li><input type="checkbox"/> MVCP089</li><li><input type="checkbox"/> MVCP090</li><li><input type="checkbox"/> MVCP091</li><li><input type="checkbox"/> MVCP128</li><li><input type="checkbox"/> MVCP130</li><li><input type="checkbox"/> MVSQ602</li><li><input type="checkbox"/> MVSQ606</li><li><input type="checkbox"/> MVSQ610</li></ul>   |
| Cum/EX Indicator                           | Select the cum/ex indicator from the possible values: <ul style="list-style-type: none"><li><input type="checkbox"/> Cum</li><li><input type="checkbox"/> Ex</li><li><input type="checkbox"/> Empty (default value)</li></ul>   |
| Settlement Transaction Condition Indicator | Select the code condition under which the trade is going to be settled from the possible values: <ul style="list-style-type: none"><li><input type="checkbox"/> Empty (default value)</li><li><input type="checkbox"/> ADEA (accept after regular settlement deadline)</li><li><input type="checkbox"/> ASGN (assignment)</li><li><input type="checkbox"/> BUTC (buy to cover)</li><li><input type="checkbox"/> BSSP (buy in partially succesful)</li><li><input type="checkbox"/> CLEN (clean)</li><li><input type="checkbox"/> DIRT (dirty)</li><li><input type="checkbox"/> DLWM (delivery without matching)</li><li><input type="checkbox"/> DRAW (drawn)</li><li><input type="checkbox"/> EXER (exercised)</li><li><input type="checkbox"/> EXPI (expired)</li><li><input type="checkbox"/> FRCL (free clean settlement)</li><li><input type="checkbox"/> KNOC (knocked out)</li><li><input type="checkbox"/> NOMC (no automatic market claim)</li></ul> |

| General   |   |
|-----------|---|
|           | <input type="checkbox"/> PENS (pending sale)<br><input type="checkbox"/> PHYS (physical)<br><input type="checkbox"/> RESI (residual)<br><input type="checkbox"/> RHYP (rehypothecation)<br><input type="checkbox"/> RPTO (reporting)<br><input type="checkbox"/> SHOR (short sell)<br><input type="checkbox"/> SPDL (special delivery)<br><input type="checkbox"/> SPST (split settlement)<br><input type="checkbox"/> TRAN (transformation)<br><input type="checkbox"/> TRIP (triparty segregation)<br><input type="checkbox"/> UNEX (unexposed)   |
| Link      |   |
| Link Type | Select a link processing position of the possible values:<br><input type="checkbox"/> After (default value)<br><input type="checkbox"/> Before<br><input type="checkbox"/> With<br><input type="checkbox"/> Info<br>References for error messages: [▶ 1054]<br><input type="checkbox"/> MVLI801<br><input type="checkbox"/> MVLI802<br><input type="checkbox"/> MVLI803<br><input type="checkbox"/> MVLI813<br><input type="checkbox"/> MVLI814<br><input type="checkbox"/> MVLI815<br><input type="checkbox"/> MVLI816<br><input type="checkbox"/> MVLI817<br><input type="checkbox"/> MVLI818<br><input type="checkbox"/> MVLI831<br><input type="checkbox"/> MVLI832<br><input type="checkbox"/> MVLI833<br><input type="checkbox"/> MVLI851<br><input type="checkbox"/> MVLI854 |



| General         |  |
|-----------------|--|
|                 | <ul style="list-style-type: none"><li><input type="checkbox"/> MVL1857</li><li><input type="checkbox"/> MVL1860</li><li><input type="checkbox"/> MVL1863</li><li><input type="checkbox"/> MVL1865</li><li><input type="checkbox"/> MVCP013</li><li><input type="checkbox"/> MVL1875</li><li><input type="checkbox"/> MVL1872</li></ul> <p>This field is also available as a show field for existing records.</p>   |
| Reference Type  | <p>Select the reference type of the instruction to be linked to from the possible values:</p> <ul style="list-style-type: none"><li><input type="checkbox"/> Account Owner Settlement Instruction Reference</li><li><input type="checkbox"/> Account Owner Intra Balance Movement Reference</li><li><input type="checkbox"/> Account Owner Intra Position Movement Reference</li><li><input type="checkbox"/> Account Servicer Reference</li><li><input type="checkbox"/> Third Party reference</li><li><input type="checkbox"/> T2S reference</li></ul> <p>Required format is: max. 46 characters (SWIFT-x)</p> <p>This field is also available as a show field for existing records.</p> |
| Reference       | <p>Enter the identification of the instruction to be linked to.</p> <p>Required format is: max. 16 characters (SWIFT-x-red)</p> <p>References for error messages: [▶ 1054]</p> <ul style="list-style-type: none"><li><input type="checkbox"/> MVCP099</li><li><input type="checkbox"/> MVL1869</li><li><input type="checkbox"/> MVL1872</li></ul> <p>This field is also available as a show field for existing records.</p>  |
| Reference Owner | <p>Enter the BIC of the instructing party of the instruction to be linked to.</p> <p>Required format is: max. 11 characters (SWIFT-x)</p> <p>If the 'Reference Type' is set to any value different than 'T2S reference' this field becomes mandatory.</p>  |

| General                                    |   |
|--|---|
|  | This field is also available as a show field for existing records.  |
| Options                                    | Information on functions (icons) can be found in Common Buttons and Icons [▶ 42].   |
| Pool Instruction Reference                 | <p>Enter the pool identification.</p> <p>Required format is: max. 16 characters (SWIFT-x-red)</p> <p>References for error messages: [▶ 1054]</p> <ul style="list-style-type: none"> <li><input type="checkbox"/> MVLI833</li> <li><input type="checkbox"/> MVLI847</li> <li><input type="checkbox"/> MVLI868</li> </ul>   |
| Pool Instruction Counter                   | <p>Enter the number of linked instructions included in the pool.</p> <p>Required format is: Integer</p> <p>References for error messages: [▶ 1054]</p> <ul style="list-style-type: none"> <li><input type="checkbox"/> MVLI843</li> <li><input type="checkbox"/> MVLI845</li> </ul> <p>This field becomes mandatory when the 'Pool Instruction Reference' is filled in.</p> |
| Current Instruction Number                 | <p>Enter the sequential number of the instruction.</p> <p>Required format is: Integer</p> <p>This field becomes mandatory when the 'Pool Instruction Reference' is filled in.</p>   |
| Pool Reference Owner BIC                   | <p>Enter the BIC of the owner of the Pool Instruction Reference.</p> <p>Required format is: max. 11 characters (SWIFT-x)</p> <p>The field 'Pool Reference Owner BIC' becomes mandatory when the field 'Pool Instruction Reference' is filled in.</p>  |
| Link Additional Information                |   |
| Message Number/ Long Number                | <p>Enter the type number/message identified of the message referenced in the linkage sequence.</p> <p>Required format is: max. 12 characters</p>  |
| Linked Quantity/ Paired Off Quantity/ Unit | Enter the quantity of the linked transaction to be paired-off expressed in units.   |

| General   |   |
|---|---|
|   | <p>Required format: max. 15 digit(s) incl. decimal point (thereof max. 14 decimal places).</p> <p>Only one of the values for quantity can be filled in: 'Unit', 'Face Amount' or 'Amortised Value'.</p> <p>If 'Paired Off Quantity' is filled in, then 'Turned Quantity' cannot be filled in.</p>   |
| Linked Quantity/<br>Paired Off Quantity/<br>Face Amount     | <p>Enter the quantity of the linked transaction to be paired-off expressed in face amount.</p> <p>Required format: max. 15 digit(s) incl. decimal point (thereof max. 5 decimal places).</p> <p>Only one of the values for quantity can be filled in: 'Unit', 'Face Amount' or 'Amortised Value'.</p> <p>If 'Paired Off Quantity' is filled in, then 'Turned Quantity' cannot be filled in.</p>     |
| Linked Quantity/<br>Paired Off Quantity/<br>Amortised Value | <p>Enter the quantity of the linked transaction to be paired-off expressed in amortised value.</p> <p>Required format: max. 15 digit(s) incl. decimal point (thereof max. 5 decimal places).</p> <p>Only one of the values for quantity can be filled in: 'Unit', 'Face Amount' or 'Amortised Value'.</p> <p>If 'Paired Off Quantity' is filled in, then 'Turned Quantity' cannot be filled in.</p> |
| Linked Quantity/<br>Turned Quantity/Unit                    | <p>Enter the quantity of the linked transaction to be turned expressed in units.</p> <p>Required format: max. 15 digit(s) incl. decimal point (thereof max. 14 decimal places).</p> <p>Only one of the values for quantity can be filled in: 'Unit', 'Face Amount' or 'Amortised Value'.</p> <p>If 'Turned Quantity' is filled in, then 'Paired Off Quantity' cannot be filled in.</p>              |
| Linked Quantity/<br>Turned Quantity/<br>Face Amount         | <p>Enter the quantity of the linked transaction to be turned expressed in face amount.</p> <p>Required format: max. 15 digit(s) incl. decimal point (thereof max. 5 decimal places).</p> <p>Only one of the values for quantity can be filled in: 'Unit', 'Face Amount' or 'Amortised Value'.</p>   |

| General   |  |
|---|--|
|   | If 'Turned Quantity' is filled in, then 'Paired Off Quantity' cannot be filled in.   |
| Linked Quantity/<br>Turned Quantity/<br>Amortised Value | <p>Enter the quantity of the linked transaction to be turned expressed in amortised value.</p> <p>Required format: max. 15 digit(s) incl. decimal point (thereof max. 5 decimal places).</p> <p>Only one of the values for quantity can be filled in: 'Unit', 'Face Amount' or 'Amortised Value'.</p> <p>If 'Turned Quantity' is filled in, then 'Paired Off Quantity' cannot be filled in.</p>  |
| Use of Restriction                                      |  |
| Cash Sub Balance<br>Type                                | <p>You can choose to either enter the code to identify the restriction on cash or to select it from the suggested items in the drop-down menu.</p> <p>Required format is: max. 4 characters (SWIFT-x)</p> <p>References for error messages: [▶ 1054]</p> <ul style="list-style-type: none"> <li><input type="checkbox"/> MVRR988</li> <li><input type="checkbox"/> MVRR926</li> <li><input type="checkbox"/> MVRR941</li> <li><input type="checkbox"/> MVRR957</li> <li><input type="checkbox"/> MVRR958</li> </ul>  |
| Delivering Securities<br>Sub Balance Type               | <p>You can choose to either enter the code to identify the restriction on securities or to select it from the suggested items in the drop-down menu. This field is only available if it is a delivering instruction or the field 'Externally Matched' is filled with 'Yes'.</p> <p>Required format is: max. 4 characters (SWIFT-x)</p> <p>References for error messages: [▶ 1054]</p> <ul style="list-style-type: none"> <li><input type="checkbox"/> MVRR937</li> <li><input type="checkbox"/> MVRR942</li> <li><input type="checkbox"/> MVRR948</li> <li><input type="checkbox"/> MVRR959</li> <li><input type="checkbox"/> MVRR960</li> <li><input type="checkbox"/> MVRR961</li> </ul> |

| General                               |  |
|---------------------------------------|--|
|                                       | <input type="checkbox"/> MVRR963<br><input type="checkbox"/> MVRR964<br><input type="checkbox"/> MVRR986<br><input type="checkbox"/> MVRR987   |
| Receiving Securities Sub Balance Type | <p>You can choose to either enter the code to identify the restriction on securities or to select it from the suggested items in the drop-down menu. This field is only available if it is a receiving instruction or the field 'Externally Matched' is filled with 'Yes'.</p> <p>Required format is: max. 4 characters (SWIFT-x)</p> <p>References for error messages: [▶ 1054]</p> <input type="checkbox"/> MVRR929<br><input type="checkbox"/> MVRR948<br><input type="checkbox"/> MVRR962<br><input type="checkbox"/> MVRR965<br><input type="checkbox"/> MVRR972<br><input type="checkbox"/> MVRR984  |
| Restriction Reference                 | <p>Enter the restriction reference applying on securities.</p> <p>Required format is: max. 30 characters (SWIFT-x-red)</p> <p>References for error messages: [▶ 1054]</p> <input type="checkbox"/> MVRR934<br><input type="checkbox"/> MVRR935<br><input type="checkbox"/> MVRR936<br><input type="checkbox"/> MVRR937<br><input type="checkbox"/> MVRR941<br><input type="checkbox"/> MVRR942<br><input type="checkbox"/> MVRR944<br><input type="checkbox"/> MVRR945<br><input type="checkbox"/> MVRR947<br><input type="checkbox"/> MVRR951<br><input type="checkbox"/> MVRR963<br><input type="checkbox"/> MVRR964<br><input type="checkbox"/> MVRR984 |

| General                                   |  |
|---|--|
|   | <input type="checkbox"/> MVRR986<br><input type="checkbox"/> MVRR987<br>Click on the '+' button to add a restriction reference.  |
| Restriction Reference                     | Shows the restriction reference applying on securities.<br>References for error messages: [▶ 1054]<br><input type="checkbox"/> MVRR934<br><input type="checkbox"/> MVRR935<br><input type="checkbox"/> MVRR936<br><input type="checkbox"/> MVRR937<br><input type="checkbox"/> MVRR941<br><input type="checkbox"/> MVRR942<br><input type="checkbox"/> MVRR944<br><input type="checkbox"/> MVRR945<br><input type="checkbox"/> MVRR947<br><input type="checkbox"/> MVRR951<br><input type="checkbox"/> MVRR963<br><input type="checkbox"/> MVRR964<br><input type="checkbox"/> MVRR984<br><input type="checkbox"/> MVRR986<br><input type="checkbox"/> MVRR987 |
| Use of Restriction Additional Information |  |
| Lot Quantity/Unit                         | Enter the quantity that is part of the lot described expressed in units.<br><br>Required format: max. 15 digit(s) incl. decimal point (thereof max. 14 decimal places).<br><br>Only one of the values for quantity can be filled in: 'Unit', 'Face Amount' or 'Amortised Value'.   |
| Lot Quantity/Face Amount                  | Enter the quantity that is part of the lot described expressed in face amount.<br><br>Required format: max. 15 digit(s) incl. decimal point (thereof max. 5 decimal places).<br><br>Only one of the values for quantity can be filled in: 'Unit', 'Face Amount' or 'Amortised Value'.  |

| General                      |   |
|------------------------------|---|
| Lot Quantity/Amortised Value | <p>Enter the quantity that is part of the lot described expressed in amortised value.</p> <p>Required format: max. 15 digit(s) incl. decimal point (thereof max. 5 decimal places).</p> <p>Only one of the values for quantity can be filled in: 'Unit', 'Face Amount' or 'Amortised Value'.</p>        |
| Lot Date Time/Date           | <p>Enter the date on which the lot was purchased or use the <i>calendar</i> icon.</p> <p>Required format: YYYY-MM-DD</p> <p>Only one field among 'Date' and 'Date Time' can be filled in.</p>   |
| Lot Date Time/Date Time      | <p>Enter the date/time on which the lot was purchased or use the <i>calendar</i> icon.</p> <p>Required format: YYYY-MM-DD hh:mm:ss.µsµsµsµsµs</p> <p>Only one field among 'Date' and 'Date Time' can be filled in.</p>  |
| Lot Price/Type/Yielded       | <p>Select whether or not the price is expressed as a yield from the possible values:</p> <p><input type="checkbox"/> Yes</p> <p><input type="checkbox"/> No</p> <p>Only one field among 'Value Type' and 'Yielded' can be filled in.</p>  |
| Lot Price/Type/Value Type    | <p>Select the type of value in which the price is expressed from the possible values:</p> <p><input type="checkbox"/> Discount (default value)</p> <p><input type="checkbox"/> Premium</p> <p><input type="checkbox"/> Par</p> <p>Only one field among 'Value Type' and 'Yielded' can be filled in.</p> |
| Lot Price/Value/Rate         | <p>Enter the price expressed as a rate.</p> <p>Required format is: max. 12 digit(s) incl. decimal point (thereof max. 10 decimal places)</p> <p>Only one field among 'Value Amount' and 'Value Rate' can be filled in.</p>  |

| General                                  |  |
|--|--|
| Lot Price/Value/<br>Amount               | <p>Enter the price expressed as a value.</p> <p>Required format is: max. 15 digit(s) incl. decimal point (thereof max. 13 decimal places)</p> <p>Only one field among 'Value Amount' and 'Value Rate' can be filled in.</p>  |
| Lot Price/Value/Currency                 | <p>Select the currency of the value amount from the drop-down menu.</p> <p>Required format is: 3 characters (SWIFT-x)</p>  |
| Type of Price/Code                       | <p>Select the ISO 20022 codes to indicate the type of price from the possible value:</p> <p><input type="checkbox"/> Average</p> <p>Only one of the following types can be filled in for a given place of trade:</p> <p>'Code' or the combination of 'Identification', 'Issuer' and optionally 'Schema Name'.</p>    |
| Type of Price/Proprietary/Identification | <p>Enter the proprietary information, often a code, of the type of price.</p> <p>Required format is: max. 4 characters (SWIFT-x)</p> <p>Only one of the following types can be filled in for a given type of price:</p> <p>'Code' or the combination of 'Identification', 'Issuer' and optionally 'Schema Name'.</p> |
| Type of Price/Proprietary/Issuer         | <p>Enter the issuer information of the type of price.</p> <p>Required format is: max. 4 characters (SWIFT-x)</p> <p>Only one of the following types can be filled in for a given type of price:</p> <p>'Code' or the combination of 'Identification', 'Issuer' and optionally 'Schema Name'.</p>                     |
| Type of Price/Proprietary/Schema Name    | <p>Enter a short textual description of the schema of the type of price.</p> <p>Required format is: max. 4 characters (SWIFT-x)</p> <p>Only one of the following types can be filled in for a given type of price:</p> <p>'Code' or the combination of 'Identification', 'Issuer' and optionally 'Schema Name'.</p>  |



| General                      |   |
|------------------------------|---|
| Additional Receiving Parties |   |
| <b>Receiving Party 3</b>     |   |
| Party BIC                    | <p>Enter the BIC of the client of the receiving CSD participant.</p> <p>Required format is: max. 11 characters (SWIFT-x)</p> <p>In case a BIC8 is entered for this field no automatic supplementation to BIC11 is performed.</p> <p>Only one of the following party identifications can be filled in for a given settlement party: 'Party BIC', 'Name' or the combination of 'Identification', 'Issuer' and optionally 'Schema Name'.</p> |
| Name                         | <p>Enter the name and address of the party.</p> <p>Required format is: max. 140 characters (SWIFT-x)</p> <p>Only one of the following party identifications can be filled in for a given settlement party: 'Party BIC', 'Name' or the combination of 'Identification', 'Issuer' and optionally 'Schema Name'.</p>   |
| Proprietary Identification   | <p>Enter the proprietary information, often a code, issued by the data source scheme issuer.</p> <p>Required format is: max. 34 characters (SWIFT-x)</p> <p>Only one of the following party identifications can be filled in for a given settlement party: 'Party BIC', 'Name' or the combination of 'Identification', 'Issuer' and optionally 'Schema Name'.</p>   |
| Issuer                       | <p>Enter the entity that assigns the identification.</p> <p>Required format is: max. 4 characters (SWIFT-x)</p> <p>Only one of the following party identifications can be filled in for a given settlement party: 'Party BIC', 'Name' or the combination of 'Identification', 'Issuer' and optionally 'Schema Name'.</p>  |
| Schema Name                  | <p>Enter the short textual description of the schema.</p> <p>Required format is: max. 4 characters (SWIFT-x)</p> <p>Only one of the following party identifications can be filled in for a given settlement party: 'Party BIC', 'Name' or the combination of 'Identification', 'Issuer' and optionally 'Schema Name'.</p>   |
| <b>Receiving Party 4</b>     |   |

| General                    |   |
|----------------------------|---|
| Party BIC                  | <p>Enter the BIC of the client of the receiving CSD participant.</p> <p>Required format is: max. 11 characters (SWIFT-x)</p> <p>In case a BIC8 is entered for this field no automatic supplementation to BIC11 is performed.</p> <p>Only one of the following party identifications can be filled in for a given settlement party: 'Party BIC', 'Name' or the combination of 'Identification', 'Issuer' and optionally 'Schema Name'.</p> |
| Name                       | <p>Enter the name and address of the party.</p> <p>Required format is: max. 140 characters (SWIFT-x)</p> <p>Only one of the following party identifications can be filled in for a given settlement party: 'Party BIC', 'Name' or the combination of 'Identification', 'Issuer' and optionally 'Schema Name'.</p>   |
| Proprietary Identification | <p>Enter the proprietary information, often a code, issued by the data source scheme issuer.</p> <p>Required format is: max. 34 characters (SWIFT-x)</p> <p>Only one of the following party identifications can be filled in for a given settlement party: 'Party BIC', 'Name' or the combination of 'Identification', 'Issuer' and optionally 'Schema Name'.</p>   |
| Issuer                     | <p>Enter the entity that assigns the identification.</p> <p>Required format is: max. 4 characters (SWIFT-x)</p> <p>Only one of the following party identifications can be filled in for a given settlement party: 'Party BIC', 'Name' or the combination of 'Identification', 'Issuer' and optionally 'Schema Name'.</p>  |
| Schema Name                | <p>Enter the short textual description of the schema.</p> <p>Required format is: max. 4 characters (SWIFT-x)</p> <p>Only one of the following party identifications can be filled in for a given settlement party: 'Party BIC', 'Name' or the combination of 'Identification', 'Issuer' and optionally 'Schema Name'.</p>   |
| Receiving Party 5          |   |
| Party BIC                  | <p>Enter the BIC of the client of the receiving CSD participant.</p> <p>Required format is: max. 11 characters (SWIFT-x)</p>  |

| General                              |   |
|--------------------------------------|---|
|                                      | <p>In case a BIC8 is entered for this field no automatic supplementation to BIC11 is performed.</p> <p>Only one of the following party identifications can be filled in for a given settlement party: 'Party BIC', 'Name' or the combination of 'Identification', 'Issuer' and optionally 'Schema Name'.</p>  |
| Name                                 | <p>Enter the name and address of the party.</p> <p>Required format is: max. 140 characters (SWIFT-x)</p> <p>Only one of the following party identifications can be filled in for a given settlement party: 'Party BIC', 'Name' or the combination of 'Identification', 'Issuer' and optionally 'Schema Name'.</p>   |
| Proprietary Identification           | <p>Enter the proprietary information, often a code, issued by the data source scheme issuer.</p> <p>Required format is: max. 34 characters (SWIFT-x)</p> <p>Only one of the following party identifications can be filled in for a given settlement party: 'Party BIC', 'Name' or the combination of 'Identification', 'Issuer' and optionally 'Schema Name'.</p> |
| Issuer                               | <p>Enter the entity that assigns the identification.</p> <p>Required format is: max. 4 characters (SWIFT-x)</p> <p>Only one of the following party identifications can be filled in for a given settlement party: 'Party BIC', 'Name' or the combination of 'Identification', 'Issuer' and optionally 'Schema Name'.</p>  |
| Schema Name                          | <p>Enter the short textual description of the schema.</p> <p>Required format is: max. 4 characters (SWIFT-x)</p> <p>Only one of the following party identifications can be filled in for a given settlement party: 'Party BIC', 'Name' or the combination of 'Identification', 'Issuer' and optionally 'Schema Name'.</p>   |
| <b>Additional Delivering Parties</b> |   |
| <b>Delivering Party 3</b>            |   |
| Party BIC                            | <p>Enter the BIC of the client of the delivering CSD participant.</p> <p>Required format is: max. 11 characters (SWIFT-x)</p>   |

| General                    |   |
|----------------------------|---|
|                            | <p>In case a BIC8 is entered for this field no automatic supplementation to BIC11 is performed.</p> <p>Only one of the following party identifications can be filled in for a given settlement party: 'Party BIC', 'Name' or the combination of 'Identification', 'Issuer' and optionally 'Schema Name'.</p>  |
| Name                       | <p>Enter the name and address of the party.</p> <p>Required format is: max. 140 characters (SWIFT-x)</p> <p>Only one of the following party identifications can be filled in for a given settlement party: 'Party BIC', 'Name' or the combination of 'Identification', 'Issuer' and optionally 'Schema Name'.</p>   |
| Proprietary Identification | <p>Enter the proprietary information, often a code, issued by the data source scheme issuer.</p> <p>Required format is: max. 34 characters (SWIFT-x)</p> <p>Only one of the following party identifications can be filled in for a given settlement party: 'Party BIC', 'Name' or the combination of 'Identification', 'Issuer' and optionally 'Schema Name'.</p> |
| Issuer                     | <p>Enter the entity that assigns the identification.</p> <p>Required format is: max. 4 characters (SWIFT-x)</p> <p>Only one of the following party identifications can be filled in for a given settlement party: 'Party BIC', 'Name' or the combination of 'Identification', 'Issuer' and optionally 'Schema Name'.</p>  |
| Schema Name                | <p>Enter the short textual description of the schema.</p> <p>Required format is: max. 4 characters (SWIFT-x)</p> <p>Only one of the following party identifications can be filled in for a given settlement party: 'Party BIC', 'Name' or the combination of 'Identification', 'Issuer' and optionally 'Schema Name'.</p>   |
| Delivering Party 4         |   |
| Party BIC                  | <p>Enter the BIC of the client of the delivering CSD participant.</p> <p>Required format is: max. 11 characters (SWIFT-x)</p>   |

| General                    |   |
|----------------------------|---|
|                            | <p>In case a BIC8 is entered for this field no automatic supplementation to BIC11 is performed.</p> <p>Only one of the following party identifications can be filled in for a given settlement party: 'Party BIC', 'Name' or the combination of 'Identification', 'Issuer' and optionally 'Schema Name'.</p>  |
| Name                       | <p>Enter the name and address of the party.</p> <p>Required format is: max. 140 characters (SWIFT-x)</p> <p>Only one of the following party identifications can be filled in for a given settlement party: 'Party BIC', 'Name' or the combination of 'Identification', 'Issuer' and optionally 'Schema Name'.</p>   |
| Proprietary Identification | <p>Enter the proprietary information, often a code, issued by the data source scheme issuer.</p> <p>Required format is: max. 34 characters (SWIFT-x)</p> <p>Only one of the following party identifications can be filled in for a given settlement party: 'Party BIC', 'Name' or the combination of 'Identification', 'Issuer' and optionally 'Schema Name'.</p> |
| Issuer                     | <p>Enter the entity that assigns the identification.</p> <p>Required format is: max. 4 characters (SWIFT-x)</p> <p>Only one of the following party identifications can be filled in for a given settlement party: 'Party BIC', 'Name' or the combination of 'Identification', 'Issuer' and optionally 'Schema Name'.</p>  |
| Schema Name                | <p>Enter the short textual description of the schema.</p> <p>Required format is: max. 4 characters (SWIFT-x)</p> <p>Only one of the following party identifications can be filled in for a given settlement party: 'Party BIC', 'Name' or the combination of 'Identification', 'Issuer' and optionally 'Schema Name'.</p>   |
| Delivering Party 5         |   |
| Party BIC                  | <p>Enter the BIC of the client of the delivering CSD participant.</p> <p>Required format is: max. 11 characters (SWIFT-x)</p>   |

| General                    |   |
|----------------------------|---|
|                            | <p>In case a BIC8 is entered for this field no automatic supplementation to BIC11 is performed.</p> <p>Only one of the following party identifications can be filled in for a given settlement party: 'Party BIC', 'Name' or the combination of 'Identification', 'Issuer' and optionally 'Schema Name'.</p>  |
| Name                       | <p>Enter the name and address of the party.</p> <p>Required format is: max. 140 characters (SWIFT-x)</p>  |
| Proprietary Identification | <p>Enter the proprietary information, often a code, issued by the data source scheme issuer.</p> <p>Required format is: max. 34 characters (SWIFT-x)</p> <p>Only one of the following party identifications can be filled in for a given settlement party: 'Party BIC', 'Name' or the combination of 'Identification', 'Issuer' and optionally 'Schema Name'.</p> |
| Issuer                     | <p>Enter the entity that assigns the identification.</p> <p>Required format is: max. 4 characters (SWIFT-x)</p> <p>Only one of the following party identifications can be filled in for a given settlement party: 'Party BIC', 'Name' or the combination of 'Identification', 'Issuer' and optionally 'Schema Name'.</p>  |
| Schema Name                | <p>Enter the short textual description of the schema.</p> <p>Required format is: max. 4 characters (SWIFT-x)</p> <p>Only one of the following party identifications can be filled in for a given settlement party: 'Party BIC', 'Name' or the combination of 'Identification', 'Issuer' and optionally 'Schema Name'.</p>   |
| Other Information          |   |
| Deal Price                 |   |
| Value Amount               | <p>Enter the value of the amount of the deal price.</p> <p>Required format is: max. 15 digit(s) incl. decimal point (thereof max. 13 decimal places)</p> <p>Only one field among 'Value Amount' and 'Value Rate' can be filled in. If any of these two fields is filled in the other one cannot be filled in.</p>   |

| General        |   |
|----------------|---|
|                | If either 'Value Amount' or 'Value Rate' is filled in, then either 'Value Type' or 'Yielded' must also be filled in.  |
| Value Currency | Select the currency of the amount of the deal price from the possible values.<br>Required format is: 3 characters (SWIFT-x)   |
| Value Rate     | Enter the price expressed as a rate.<br>Required format is: max. 12 digit(s) incl. decimal point (thereof max. 10 decimal places)<br>Only one field among 'Value Amount' and 'Value Rate' can be filled in. If any of these two fields is filled in the other one cannot be filled in.<br>If either 'Value Amount' or 'Value Rate' is filled in, then either 'Value Type' or 'Yielded' must also be filled in.  |
| Value Type     | Select the type of value in which the price is expressed from the possible values:<br><input type="checkbox"/> Empty (default value)<br><input type="checkbox"/> Discount<br><input type="checkbox"/> Par<br><input type="checkbox"/> Premium<br>Only one field among 'Value Type' and 'Yielded' can be filled in. If any of these two fields is filled in the other one cannot be filled in.<br>If either 'Value Type' or 'Yielded' is filled in, then either 'Value Amount' or 'Value Rate' must also be filled in. |
| Yielded        | Select yes or no to indicate that the price is expressed as a yield.<br>Possible values:<br><input type="checkbox"/> Empty (default value)<br><input type="checkbox"/> Yes<br><input type="checkbox"/> No<br>Only one field among 'Value Type' and 'Yielded' can be filled in. If any of these two fields is filled in the other one cannot be filled in.<br>If either 'Value Type' or 'Yielded' is filled in, then either 'Value Amount' or 'Value Rate' must also be filled in.                                     |

| General                               |   |
|---------------------------------------|---|
| Foreign Exchange                      |   |
| Exchange Rate                         | Enter the factor used for the conversion of an amount from one currency into another. This reflects the price at which one currency was bought with another currency.<br><br>Required format is: max. 12 digit(s) incl. decimal point (thereof max. 10 decimal places)                        |
| Quoted Currency                       | Select the currency into which the base currency is converted, in a currency exchange from the drop-down menu.  |
| Resulting Amount                      | Enter the counter value of a foreign exchange conversion.<br><br>Required format is: max. 15 digit(s) incl. decimal point (thereof max. 5 decimal places)   |
| Resulting Amount Currency             | Select the currency of the counter value of a foreign exchange conversion from the drop-down menu.  |
| Unit Currency                         | Select the currency into which the base currency is converted, in a currency exchange for unit from the drop-down menu.   |
| Place of Trade                        |   |
| Place of Trade Description            | Enter the description of the market in which a trade transaction has been executed.<br><br>Either this field or Place of Trade Market Identifier Code can be filled, but not both.<br><br>Required format is: max. 30 characters (SWIFT-x-red)  |
| Place of Trade Market Identifier Code | Enter the Identifier Code of the market in which a trade transaction has been executed.<br><br>Either this field or Place of Trade Description can be filled, but not both.<br><br>Required format is: max. 4 characters (SWIFT-x)  |
| Place of Trade Additional Information |   |
| Type/Code                             | Select the ISO 20022 code to indicate the type of market in which transactions take place from the possible values:<br><br><input type="checkbox"/> PRIM (for Primary Market)<br><input type="checkbox"/> SECM (for Secondary Market)<br><input type="checkbox"/> OTCO (for Over the Counter) |



| General                         |  |
|---------------------------------|--|
|                                 | <input type="checkbox"/> VARI (for Various)<br><input type="checkbox"/> EXCH (for Stock Exchange)<br>Required format is: max. 4 characters (SWIFT-x).<br>In case either 'Place of Trade Description' or 'Place of Trade Market Identifier Code' are filled, either 'Place of Trade Code' or Proprietary Information must be provided.<br>Only one of the following types can be filled in for a given place of trade:<br>'Code' or the combination of 'Identification', 'Issuer' and optionally 'Schema Name'. |
| Type/Proprietary/Identification | Enter the proprietary information, often a code, of the place of trade type.<br>Required format is: max. 4 characters (SWIFT-x).<br>Only one of the following types can be filled in for a given place of trade:<br>'Code' or the combination of 'Identification', 'Issuer' and optionally 'Schema Name'.  |
| Type/Proprietary/Issuer         | Enter the issuer information of the place of trade type.<br>Required format is: max. 4 characters (SWIFT-x).<br>Only one of the following types can be filled in for a given place of trade:<br>'Code' or the combination of 'Identification', 'Issuer' and optionally 'Schema Name'.  |
| Type/Proprietary/Schema Name    | Enter a short textual description of the schema of the place of trade type.<br>Required format is: max. 4 characters (SWIFT-x).<br>Only one of the following types can be filled in for a given place of trade:<br>'Code' or the combination of 'Identification', 'Issuer' and optionally 'Schema Name'.   |
| Other Information               |  |
| Other                           |  |
| Number of Days Accrued          | Enter the number of days on which the interest rate accrues (daily accrual note).<br>Required format is: Integer values from -999 to 999   |

| General                                       |  |
|---|--|
| Original Ordered Amount                       | Enter the original ordered amount.<br>Required format is: max. 15 digit(s) incl. decimal point (thereof max. 5 decimal places)   |
| Original Ordered Currency                     | Select the currency of the original ordered amount from the drop-down menu.  |
| Market Client Side Code                       | Specifies if an instruction is for a market side or client side transaction:<br><br><input type="checkbox"/> CLNT (for Client Side)<br><input type="checkbox"/> MAKT (for Market Side)<br><br>Either this field or the proprietary identification of the market client side in addition to the issuer and scheme name is available.<br><br>Required format is: max. 4 characters (SWIFT-x) |
| Market Client Side Proprietary Identification | Select the identification assigned by an institution.<br>In case Proprietary Information is filled, at least Identification and Issuer must be provided.<br><br>Required format is: max. 4 characters (SWIFT-x)  |
| Market Client Side Issuer                     | Select the entity that assigns the identification.<br>In case Proprietary Information is filled, at least Identification and Issuer must be provided.<br><br>Required format is: max. 4 characters (SWIFT-x)   |
| Market Client Side Schema Name                | Select the name of the identification scheme.<br>Required format is: max. 4 characters (SWIFT-x)   |
| Additional Information                        |  |
| Level 1                                       | Select the first level of the XML hierarchy.   |
| Level 2                                       | Select the second level of the XML hierarchy.  |
| Level 3                                       | Select the third level of the XML hierarchy.   |
| Level 4                                       | Select the fourth level of the XML hierarchy.  |
| Level 5                                       | Select the fifth level of the XML hierarchy.   |
| Level 6                                       | Select the sixth level of the XML hierarchy.   |
| Value   | Enter the value of the corresponding XML field chosen through the different levels.  |
| Path  | Shows the XML selected hierarchy.  |

| General |   |
|---------|---|
| Value   | Shows the value of the corresponding XML field chosen through the different levels. |

## Buttons

| Cancel | <p>This function enables you to cancel the process and return to the previous screen.</p> <p>Next screen:</p> <ul style="list-style-type: none"><li><input type="checkbox"/> <i>Settlement instructions – search/list</i> screen [▶ 176]</li></ul>   |
|--------|--|
| Reset  | <p>This function enables you to set all fields to default value and blanks out all optional fields.</p> <p>Next screen:</p> <ul style="list-style-type: none"><li><input type="checkbox"/> <i>Settlement instruction – new</i> screen</li></ul>  |
| Submit | <p>This function enables you to create a new settlement instruction. Upon clicking on the <i>submit</i> button you will be asked to enter your PIN for digital signature purposes (NRO). With the entry of the PIN, T2S attaches a digital signature to the instruction entered by the T2S actor.</p> <p>Next screen:</p> <ul style="list-style-type: none"><li><input type="checkbox"/> <i>Settlement instructions – search/list</i> screen [▶ 176]</li></ul> <p>References for error messages: [▶ 1054]</p> <ul style="list-style-type: none"><li><input type="checkbox"/> MVCA105</li><li><input type="checkbox"/> MVCA501</li><li><input type="checkbox"/> MVCA502</li><li><input type="checkbox"/> MVCA503</li><li><input type="checkbox"/> MVCA505</li><li><input type="checkbox"/> MVCA506</li><li><input type="checkbox"/> MVCA507</li><li><input type="checkbox"/> MVCA509</li><li><input type="checkbox"/> MVCA510</li><li><input type="checkbox"/> MVCA511</li><li><input type="checkbox"/> MVCA514</li><li><input type="checkbox"/> MVCA515</li><li><input type="checkbox"/> MVCA516</li></ul> |

- MVCA517
- MVCA518
- MVCA519
- MVCP009
- MVCP010
- MVCP011
- MVCP012
- MVCP013
- MVCP036
- MVCP037
- MVCP052
- MVCP053
- MVCP054
- MVCP055
- MVCP056
- MVCP057
- MVCP058
- MVCP059
- MVCP060
- MVCP061
- MVCP062
- MVCP063
- MVCP064
- MVCP065
- MVCP066
- MVCP067
- MVCP068
- MVCP069
- MVCP070
- MVCP071
- MVCP072
- MVCP073

- MVCP074
- MVCP075
- MVCP076
- MVCP077
- MVCP078
- MVCP079
- MVCP080
- MVCP081
- MVCP082
- MVCP083
- MVCP084
- MVCP085
- MVCP086
- MVCP087
- MVCP088
- MVCP089
- MVCP090
- MVCP091
- MVCP092
- MVCP099
- MVCP102
- MVCP103
- MVCP110
- MVCP119
- MVCP124
- MVCP125
- MVCP126
- MVCP127
- MVCP128
- MVCP130
- MVCU103
- MVCU107

- MVCV001
- MVCV002
- MVCV003
- MVCV106
- MVCV120
- MVCV122
- MVCV123
- MVCV205
- MVCV229
- MVCV234
- MVCV235
- MVCV236
- MVCV237
- MVCV238
- MVCV239
- MVCV241
- MVCV242
- MVCV243
- MVCV244
- MVCV245
- MVCV246
- MVCV247
- MVCV248
- MVCV249
- MVCV250
- MVCV251
- MVCV252
- MVCV253
- MVCV256
- MVCV257
- MVCV271
- MVCV272

- MVCV273
- MVCV274
- MVCV275
- MVCV276
- MVCV277
- MVCV278
- MVCV279
- MVCV280
- MVCV281
- MVCV282
- MVCV283
- MVCV286
- MVCV287
- MVCV288
- MVCV289
- MVCV298
- MVCV299
- MVCV301
- MVCV303
- MVCV305
- MVDC002
- MVDC004
- MVDC006
- MVDC014
- MVDC016
- MVDC018
- MVDC021
- MVDC024
- MVIC305
- MVIC307
- MVIC308
- MVIC309

- MVIC311
- MVIC313
- MVIC315
- MVIC316
- MVIC317
- MVIC318
- MVIC319
- MVIC320
- MVLI801
- MVLI802
- MVLI803
- MVLI813
- MVLI814
- MVLI815
- MVLI816
- MVLI817
- MVLI818
- MVLI831
- MVLI832
- MVLI833
- MVLI843
- MVLI845
- MVLI847
- MVLI851
- MVLI854
- MVLI857
- MVLI860
- MVLI863
- MVLI865
- MVLI868
- MVLI869
- MVLI872



- MVLI875
- MVRR926
- MVRR929
- MVRR934
- MVRR935
- MVRR936
- MVRR937
- MVRR941
- MVRR942
- MVRR944
- MVRR945
- MVRR947
- MVRR948
- MVRR951
- MVRR957
- MVRR958
- MVRR959
- MVRR960
- MVRR961
- MVRR963
- MVRR964
- MVRR984
- MVRR986
- MVRR987
- MVSD401
- MVSD403
- MVSD406
- MVSD411
- MVSD412
- MVSP208
- MVSQ602
- MVSQ604

|                          |         |
|--------------------------|---------|
| <input type="checkbox"/> | MVSQ606 |
| <input type="checkbox"/> | MVSQ610 |
| <input type="checkbox"/> | MVSQ612 |
| <input type="checkbox"/> | MVSR701 |
| <input type="checkbox"/> | MVSR702 |
| <input type="checkbox"/> | MVSR703 |
| <input type="checkbox"/> | MVSR704 |
| <input type="checkbox"/> | MVSR707 |

## 2.2.2.20 Status History - Details Screen

### Context of Usage

This screen displays detailed information on the status history of the selected instruction. You can check the data.

There is no usage restriction for this screen.

### Screen Access

- Securities >> Settlement >> Intra-Position Movements >> *Intra-position movements with current and historical status – search* screen >> Click on the *search* button >> *Intra-position movements – list* screen >> Click on the *details* button >> *Intra-position movement - details* screen >> Click on the *status history* button
- Securities >> Settlement >> Intra-Balance Movements >> *Intra-balance movements with current and historical status – search* screen >> Click on the *search* button >> *Intra-balance movements – list* screen >> Click on the *details* button >> *Intra-balance movement - details* screen >> Click on the *status history* button
- Securities >> Settlement >> Settlement Instructions >> *Settlement instructions with current and historical status – search* screen >> Click on the *search* button >> *Settlement instructions – list* screen >> Click on the *details* button >> *Settlement instruction – details* screen >> Click on the *status history* button
- Securities >> Settlement >> Maintenance Securities Instructions >> *Maintenance securities instructions - search* screen >> Click on the *search* button >> *Maintenance securities instructions - list* screen >> Click on the *details* button >> *Amendment securities instruction – details* screen >> Click on the *status history* button

- Securities >> Settlement >> Maintenance Securities Instructions >> *Maintenance securities instructions - search* screen >> Click on the *search* button >> *Maintenance securities instructions - list* screen >> Click on the *details* button >> *Cancellation securities instruction – details* screen >> Click on the *status history* button
- Securities >> Settlement >> Maintenance Securities Instructions >> *Maintenance securities instructions - search* screen >> Click on the *search* button >> *Maintenance securities instructions - list* screen >> Click on the *details* button >> *Hold/release Instruction – details* screen >> Click on the *status history* button
- Cash >> Settlement >> Maintenance Cash Instructions >> *Maintenance cash instructions - search* screen >> Click on the *search* button >> *Maintenance cash instructions - list* screen >> Click on the *details* button >> *Amendment cash instruction – details* screen >> Click on the *status history* button
- Cash >> Settlement >> Maintenance Cash Instructions >> *Maintenance cash instructions - search* screen >> Click on the *search* button >> *Maintenance cash instructions - list* screen >> Click on the *details* button >> *Cancellation cash instruction – details* screen >> Click on the *status history* button

**Privileges** To use this screen, you need the privileges necessary for the business object for which you want to view the status history.

**References** **User Instructions Part**

This screen is part of the following business scenario:

- View settlement instruction status history [▶ 732]

**Business Functionality Document**

This screen corresponds to the following business function:

- Display instruction details (T2S.GUI.SESE.INX.0030)

Screenshot

| Date and Time       | Status Type         | Status Value        | Settled Settlement Amount | Settled Settlement Quantity |
|---------------------|---------------------|---------------------|---------------------------|-----------------------------|
| 2018-10-19 09:13:43 | Settlement Status   | Settled             |                           | 1                           |
| 2018-10-18 19:39:16 | Settlement Status   | Unsettled - Failing |                           |                             |
| 2018-10-18 19:33:26 | Settlement Status   | Unsettled - Failing |                           |                             |
| 2018-10-18 19:19:41 | Settlement Status   | Unsettled - Failing |                           |                             |
| 2018-10-16 11:23:28 | Settlement Status   | Unsettled - Pending |                           |                             |
| 2018-10-15 11:23:26 | Match Status        | Matched             |                           |                             |
| 2018-10-15 11:23:25 | Match Status        | Unmatched           |                           |                             |
| 2018-10-15 11:23:25 | Settlement Status   | Unsettled - Pending |                           |                             |
| 2018-10-15 11:23:25 | Cancellation Status | Not cancelled       |                           |                             |
| 2018-10-15 11:23:25 | Approval Status     | Approved            |                           |                             |

Illustration 59: Status history - details screen

Field Description

| Settlement Instruction - Status History |   |
|---|---|
| Instruction                             | Shows the reference of the instruction for which the status history is shown.<br><br>Displayed format is: max. 16 characters (SWIFT-x)  |
| Effective Date and Time                 | Shows the timestamp when the status query was made.<br><br>Displayed format is: YYYY-MM-DD hh:mm:ss   |
| Date and Time                           | Shows the date and time when the status value was modified.<br><br>Displayed format is: YYYY-MM-DD hh:mm:ss   |
| Status Type                             | Shows the status type depending on the instruction type from the possible values: <ul style="list-style-type: none"> <li><input type="checkbox"/> Settlement Status (for settlement instructions and restrictions)</li> <li><input type="checkbox"/> Match Status (for all types of LCMM instructions)</li> <li><input type="checkbox"/> Cancellation Status (for all types of LCMM instructions)</li> <li><input type="checkbox"/> Party Hold (for settlement instructions)</li> <li><input type="checkbox"/> CSD Hold Status (for settlement instructions)</li> <li><input type="checkbox"/> CSD Validation Hold Status (for settlement instructions)</li> <li><input type="checkbox"/> CoSD Hold Status (for settlement instructions)</li> <li><input type="checkbox"/> Execution Status (for cancellation instructions and condition modification instructions)</li> <li><input type="checkbox"/> Approval Status (for all types of LCMM instructions)</li> </ul> |

| Settlement Instruction - Status History |  |
|---|--|
| Status Value                            | Shows the status value of the 'Status Type' field depending on the status type and the instruction type from the possible values: <ul style="list-style-type: none"> <li><input type="checkbox"/> Match status: 'Matched' or 'Unmatched'</li> <li><input type="checkbox"/> Cancellation status for settlement instructions and restrictions: 'Cancelled' or 'Not Cancelled'</li> <li><input type="checkbox"/> Cancellation status for cancellation instructions and condition modification instructions: 'Denied' or 'Not Denied'</li> <li><input type="checkbox"/> Settlement status: 'Unsettled'- Pending' or 'Unsettled - Failing' or 'Partially Settled'- Pending' or 'Partially Settled' - Failing' or 'Settled'</li> <li><input type="checkbox"/> CoSD hold status: 'Yes' or 'No'</li> <li><input type="checkbox"/> Party hold status: 'Yes' or 'No'</li> <li><input type="checkbox"/> CSD hold status: 'Yes' or 'No'</li> <li><input type="checkbox"/> CSD validation hold status : 'Yes' or 'No'</li> <li><input type="checkbox"/> Execution status: 'Executed' or 'Not Executed'</li> <li><input type="checkbox"/> Approval status: 'Approved' or 'Awaiting for Approval' or 'Revoked'</li> </ul> |
| Settled Settlement Amount               | Shows the amount settled in the current status update. This field is only filled for an update in a settlement status.   |
| Settled Settlement Quantity             | Shows the quantity settled in the current status update. This field is only filled for an update in a settlement status.   |

### 2.2.2.21 Insolvency procedure Settlement Instructions - Search/List Screen

**Context of Usage**

This screen contains a number of search fields. By inputting the relevant data, you can search for settlement instructions under insolvency situation. The search results will be displayed in a list.

After selecting an entry, you can proceed further by clicking on the buttons below.

This screen will be available for the User in case the Insolvency system parameter is activated.

When exporting the content of this screen, you receive the query result in a csv-file.

This screen is not relevant for CB users.

**Screen Access**  Securities >> Settlement >> Insolvency procedure Settlement Instructions

**Privileges** To use this screen, you need the following privilege [[▶ 885](#)]:

- Settlement instruction matched and accepted status query privilege

**References** **User Instructions Part**

This screen is part of the following business scenario:

- View SF1/SF2 timestamps of Settlement Instructions in case of Insolvency situation [[▶ 733](#)]

**Business Functionality Document**

This screen corresponds to the following business functions:

- Query instruction (T2S.GUI.SESE.INX.0010)
- Display instruction list (T2S.GUI.SESE.INX.0020)

**Screenshot**

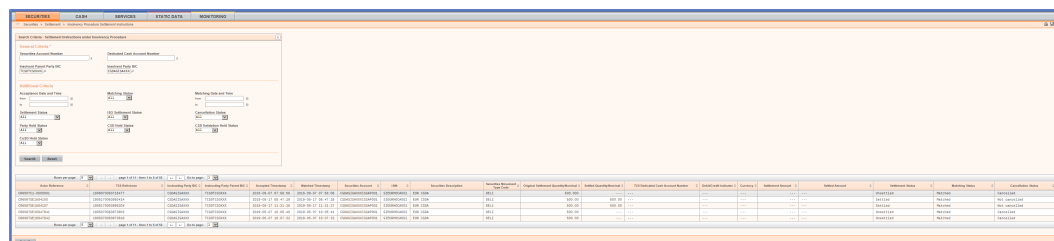

Illustration 60: Insolvency procedure settlement instructions –search/list screen

**Field description**

| Insolvency procedure Settlement Instructions – Search Criteria |  |
|--|--|
| Insolvent Object Criteria*                                     |  |
| Securities Account Number                                      | <p>You can choose to either enter the ‘Securities Account Number’ or to select it from the suggested items in the drop-down menu.</p> <p>Only one of the insolvent object criteria must be filled in: ‘Securities Account Number’, ‘Dedicated Cash Account Number’ or the combination of ‘Insolvent Party BIC’ and ‘Insolvent Parent Party BIC’.</p> <p>In order to query external CSD settlement instructions the search criterion ‘securities account’ must not be filled in.</p> <p>Required format is: max. 35 characters (SWIFT-x)</p> <p>Reference for error message [<a href="#">▶ 993</a>]:</p> <ul style="list-style-type: none"> <li><input type="checkbox"/> QMPC030</li> </ul> |
| Dedicated Cash Account Number                                  | <p>You can choose to either enter the ‘Dedicated Cash Account Number’ or to select it from the suggested items in the drop-down menu.</p>  |

| Insolvency procedure Settlement Instructions – Search Criteria |  |
|--|--|
|  | <p>Only one of the insolvent object criteria must be filled in: 'Securities Account Number', 'Dedicated Cash Account Number' or the combination of 'Insolvent Party BIC' and 'Insolvent Parent Party BIC'.</p> <p>Required format is: max. 34 characters (SWIFT-x)</p> <p>Reference for error message [ ▶ 993]:</p> <ul style="list-style-type: none"><li><input type="checkbox"/> QMPC031</li></ul>   |
| Insolvent Party BIC  | <p>You can choose to either enter the 'Insolvent Party BIC' or to select it from the suggested items in the drop-down menu.</p> <p>Only one of the insolvent object criteria must be filled: 'Securities Account Number', 'Dedicated Cash Account Number' or the combination of 'Insolvent Party BIC' and 'Insolvent Parent Party BIC'.</p> <p>If the Insolvent Party BIC is filled in, the Insolvent Parent Party BIC needs to be filled in as well.</p> <p>Required format is: max. 11 characters (SWIFT-x)</p> <p>References for error messages [ ▶ 993]:</p> <ul style="list-style-type: none"><li><input type="checkbox"/> QMPC032</li><li><input type="checkbox"/> QMPC084</li></ul>           |
| Insolvent Parent Party BIC                                     | <p>You can choose to either enter the 'Insolvent Party Parent BIC' or to select it from the suggested items in the drop-down menu.</p> <p>Only one of the insolvent object criteria must be filled in: 'Securities Account Number', 'Dedicated Cash Account Number' or the combination of 'Insolvent Party BIC' and 'Insolvent Parent Party BIC'.</p> <p>If the Insolvent Parent Party BIC is filled in, the Insolvent Party BIC needs to be filled in as well.</p> <p>Required format is: max. 11 characters (SWIFT-x)</p> <p>References for error messages [ ▶ 993]:</p> <ul style="list-style-type: none"><li><input type="checkbox"/> QMPC048</li><li><input type="checkbox"/> QMPC084</li></ul> |
| Additional Criteria  |  |

| Insolvency procedure Settlement Instructions – Search Criteria |  |
|--|--|
| Acceptance Date and Time – from                                | <p>Enter the lower bound of the search range for the acceptance date and time (i.e. SF1: moment of acceptance) or use the <i>calendar</i> icon.</p> <p>Required format is: YYYY-MM-DD hh:mm:ss</p> <p>Reference for error message [ ▶ 993]:</p> <ul style="list-style-type: none"><li><input type="checkbox"/> QMPC015</li></ul> <p>Only Settlement Instructions successfully created in 4-eyes mode (i.e. approval status = approved) will be considered in the query. Settlement Instructions with other approval status value will not be included in the search results.</p> |
| Acceptance Date and Time – to                                  | <p>Enter the upper bound of the search range for the acceptance date and time (i.e. SF1: moment of acceptance) or use the <i>calendar</i> icon.</p> <p>Required format is: YYYY-MM-DD hh:mm:ss</p> <p>Reference for error message [ ▶ 993]:</p> <ul style="list-style-type: none"><li><input type="checkbox"/> QMPC015</li></ul> <p>Only Settlement Instructions successfully created in 4-eyes mode (i.e. approval status = approved) will be considered in the query. Settlement Instructions with other approval status value will not be included in the query results.</p>  |
| Matching Status  | <p>Select the matching status from the possible values:</p> <ul style="list-style-type: none"><li><input type="checkbox"/> All (default value)</li><li><input type="checkbox"/> Unmatched</li><li><input type="checkbox"/> Matched</li></ul>   |
| Matching Date and Time - from                                  | <p>Enter the lower bound of the search range for the matching date and time (i.e. SF2: moment of irrevocability) or use the <i>calendar</i> icon.</p> <p>Required format is: YYYY-MM-DD hh:mm:ss</p> <p>Reference for error message [ ▶ 993]:</p> <ul style="list-style-type: none"><li><input type="checkbox"/> QMPC015</li></ul>   |
| Matching Date and Time - to                                    | <p>Enter the upper bound of the search range for the matching date and time (i.e. SF2: moment of irrevocability) or use the <i>calendar</i> icon.</p>  |



| Insolvency procedure Settlement Instructions – Search Criteria |  |
|--|--|
|  | Required format is: YYYY-MM-DD hh:mm:ss<br>Reference for error message [▶ 993]:<br><input type="checkbox"/> QMPC015  |
| Settlement Status  | Select the settlement status from the possible values:<br><input type="checkbox"/> All (default value)<br><input type="checkbox"/> Unsettled<br><input type="checkbox"/> Settled<br><input type="checkbox"/> Partially settled   |
| ISO Settlement status  | Select the settlement status of the settlement restriction from the possible values:<br><input type="checkbox"/> All (default value)<br><input type="checkbox"/> Pending<br><input type="checkbox"/> Failing<br><br>If value 'Settlement Status' field is set to 'Settled' or 'Cancellation Status' field is set to 'Cancelled', this field is disabled. |
| Cancellation Status  | Select the cancellation status from the possible values:<br><input type="checkbox"/> All (default value)<br><input type="checkbox"/> Cancelled<br><input type="checkbox"/> Not cancelled   |
| Party Hold Status  | Select the party hold status from the possible values:<br><input type="checkbox"/> All (default value)<br><input type="checkbox"/> On hold<br><input type="checkbox"/> Released  |
| CSD Hold Status  | Select the CSD hold status from the possible values:<br><input type="checkbox"/> All (default value)<br><input type="checkbox"/> On hold<br><input type="checkbox"/> Released  |
| CSD Validation Hold Status                                     | Select the CSD validation hold status from the possible values:<br><input type="checkbox"/> All (default value)<br><input type="checkbox"/> On hold<br><input type="checkbox"/> Released   |

| Insolvency procedure Settlement Instructions – Search Criteria |  |
|--|--|
| CoSD Hold status   | Select the CoSD hold status from the possible values:<br><input type="checkbox"/> All (default value)<br><input type="checkbox"/> On hold<br><input type="checkbox"/> Released |
| Insolvency procedure Settlement Instructions - List            |  |
| Actor Reference  | Shows the reference assigned by the Actor to the settlement instruction.   |
| T2S Reference  | Shows the reference assigned by T2S to the settlement instruction.   |
| Instructing Party BIC  | Shows the BIC of the instructing party of the settlement instruction.  |
| Instructing Party Parent BIC                                   | Shows the parent BIC of the instructing party of the settlement instruction.   |
| Accepted Timestamp (SF1)                                       | Shows the accepted timestamp of the settlement instruction.  |
| Matched Timestamp (SF2)  | Shows the matched timestamp of the settlement instruction.<br><br>In case the settlement instruction is unmatched no timestamp will be shown.                                  |
| Securities Account Number                                      | Shows the securities account number to or from which a securities entry is made.   |
| ISIN   | Shows the ISIN code of the security.   |
| Securities Description   | Shows the description of the security.   |
| Securities Movement Type Code                                  | Shows the securities movement type code from the possible values:<br><input type="checkbox"/> DELI<br><input type="checkbox"/> RECE  |
| Original Settlement Quantity/Nominal                           | Shows the quantity of securities to be settled.  |
| Settled Quantity/Nominal                                       | Shows the settled quantity of the settlement instructions.   |

| Insolvency procedure Settlement Instructions – Search Criteria |   |
|--|---|
| T2S Dedicated Cash Account Number                              | Shows the T2S dedicated cash account number stated in the settlement instruction or the default T2S dedicated cash account number in case it was not stated in the settlement instruction.  |
| Debit/Credit Indicator   | Shows the debit credit indicator related to the cash posting from one of the possible values: <ul style="list-style-type: none"> <li><input type="checkbox"/> DEBIT</li> <li><input type="checkbox"/> CREDIT</li> <li><input type="checkbox"/> Empty</li> </ul> In case the settlement instruction does not contain the debit credit information, no value will be shown. |
| Currency   | Shows the currency stated in the settlement instruction.  |
| Settlement Amount  | Shows the settlement amount as stated in the settlement instruction.<br><br>In case the settlement instruction does not contain the Settlement Amount information, no value will be shown.  |
| Settled Amount   | Shows the total settled amount.   |
| Settlement Status  | Shows the settlement status of the settlement instruction.<br><br>Possible values: <ul style="list-style-type: none"> <li><input type="checkbox"/> Unsettled</li> <li><input type="checkbox"/> Settled</li> <li><input type="checkbox"/> Partially settled</li> </ul>   |
| Matching Status  | Shows the matching status of the settlement instruction.<br><br>Possible values: <ul style="list-style-type: none"> <li><input type="checkbox"/> Unmatched</li> <li><input type="checkbox"/> Matched</li> </ul>   |
| Cancellation Status  | Shows the cancellation status of the settlement instruction.<br><br>Possible values: <ul style="list-style-type: none"> <li><input type="checkbox"/> Cancelled</li> <li><input type="checkbox"/> Not Cancelled</li> </ul>   |

## Buttons

|        |  |
|--------|--|
| Search | This function enables you to start a search according to the criteria entered. The results are displayed in a list on the next screen. |
|--------|--|

|         |  |
|---------|--|
|         | <p>If the search retrieves a single record, the <i>settlement instruction - details</i> screen is displayed (to retrieve the relevant timestamps, the <i>back</i> icon of the <i>settlement instruction - details</i> screen must be used).</p> <p>Next screen:</p> <ul style="list-style-type: none"> <li><input type="checkbox"/> <i>Insolvency procedure settlement instructions – search/ list</i> screen</li> <li><input type="checkbox"/> <i>Settlement instruction – details</i> screen [▶ 191]</li> </ul> <p>References for error messages [▶ 993]:</p> <ul style="list-style-type: none"> <li><input type="checkbox"/> QMPC015</li> <li><input type="checkbox"/> QMPC030</li> <li><input type="checkbox"/> QMPC031</li> <li><input type="checkbox"/> QMPC032</li> <li><input type="checkbox"/> QMPC048</li> <li><input type="checkbox"/> QMPC084</li> </ul> |
| Reset   | <p>This function enables you to set all fields to default value and blanks out all optional fields</p> <p>Next screen:</p> <ul style="list-style-type: none"> <li><input type="checkbox"/> <i>Insolvency procedure settlement instructions – search/ list</i> screen</li> </ul>  |
| Details | <p>This function enables you to display the details of the selected instruction.</p> <p>Next screen:</p> <ul style="list-style-type: none"> <li><input type="checkbox"/> <i>Settlement Instruction – details</i> screen [▶ 191]</li> </ul>   |

## 2.2.2.22 Links Preventing Settlement - List Screen

### Context of Usage

This screen displays the list of all the linked instructions preventing settlement of the selected instruction with the associated constraints.

You can perform the following action: You can check the data.

### Screen Access

- Securities >> Settlement >> Settlement Instructions >> *Settlement instructions – search/list* screen >> Click on the *search* button >> *Settlement instructions – search/list* screen >> Click on the *details* button >> *Settlement instruction - details* screen >> Click on the *Links* button

- Securities >> Settlement >> Intra-Position Movements >> *Intra-position movements – search/list* screen >> Click on the *search* button >> *Intra-position movements – search/list* screen >> Click on the *details* button >> *Intra-position movement - details* screen >> Click on the *Links* button
- Cash >> Settlement >> Intra-Balance Movements >> *Intra-balance movements – search/list* screen >> Click on the *search* button >> *Intra-balance movements – search/list* screen >> Click on the *details* button >> *Intra-balance movement - details* screen >> Click on the *Links* button

**Privileges**

To use this screen, you need the following privileges:

- Settlement instruction audit trail query
- Intra position movements query
- Intra balance movement audit trail list query

**References**

**User Instructions Part**

This screen is part of the following business scenarios:

- View the list of links data preventing settlement of a selected settlement instruction
- View the list of links data preventing settlement of a selected settlement restriction on securities
- View the list of links data preventing settlement of a selected settlement restriction on cash

**Business Functionality Document**

This screen corresponds to the following business functions:

- Query instruction (T2S.GUI.SESE.INX.0010)
- Display instruction list (T2S.GUI.SESE.INX.0020)

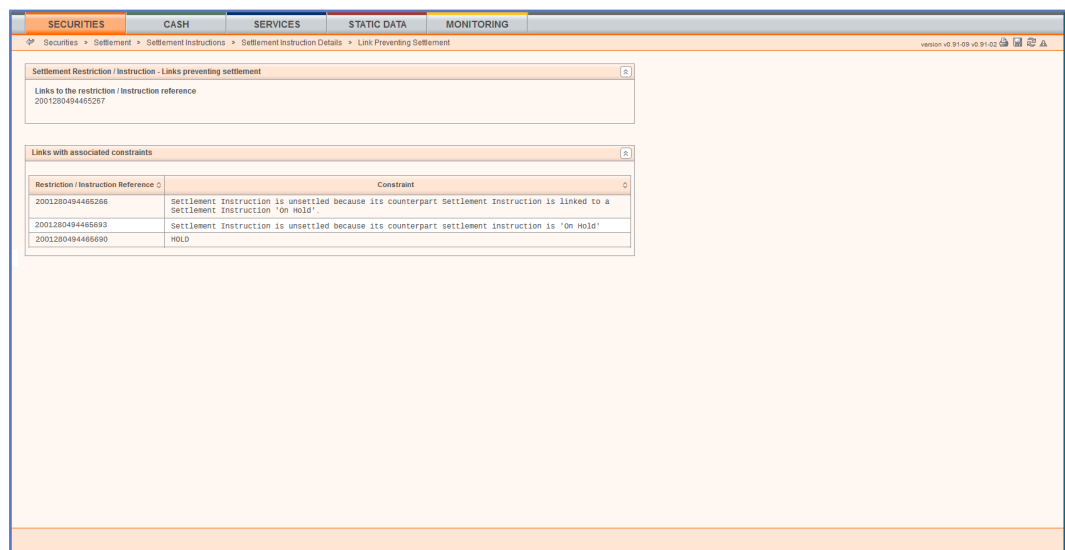

Illustration 61: Links preventing settlement – list screen

| Field              | Settlement Restriction / Instruction – Links preventing settlement |  |
|--------------------|--|--|
| <b>Description</b> | Links to the restriction / Instruction reference                   | Shows the T2S Reference assigned by T2S to the settlement instruction or settlement restriction selected in one of the following screens: <ul style="list-style-type: none"> <li><input type="checkbox"/> Settlement instruction details</li> <li><input type="checkbox"/> Intra-Position movement details</li> <li><input type="checkbox"/> Intra-balance movement details</li> </ul> |
|                    | Links with associated constraints                                  |  |
|                    | Restriction / Instruction reference                                | Shows the T2S Reference of the linked settlement restriction or settlement instruction preventing the settlement of the selected settlement instruction or settlement restriction  |
|                    | Constraint   | Lists the constraint applied to the linked settlement instruction or settlement restriction preventing the settlement of the selected settlement instruction or settlement restriction   |

### 2.2.2.23 Penalty - Search/List Screen

#### Context of Usage

This screen contains a number of search fields. By inputting the relevant data, you can search for penalties computed for settlement instructions.

This screen is structured according to the allowed queries.

This screen will only return results where the relevant CSD has the right to access the underlying data (i.e. the penalty is in its data scope).

The search results will be displayed in a list when more than one result is retrieved by T2S. After selecting an entry, you can proceed further by clicking on the buttons below.

When only one result is retrieved, the Penalty – details Screen will be displayed.

When exporting the content of this screen, you receive the query result in a csv-file.

This screen is only available for CSD authorised users and T2S Operator user.

This screen will not be available during the processing of penalties, i.e. between the Events “PMSS” (Penalty Mechanism- Stop Screens and penalty modification requests) and “PMRR” (Penalty Mechanism- Restart GUI and Restart processing penalty modification requests).

**Screen Access**

- Securities >> Settlement >> Daily Penalties
- Securities >> Settlement >> Settlement Instructions >> *Settlement instructions – search/list* screen >> Click on the *search* button >> *Settlement instructions – search/list* screen >> Click on the *details* button >> *Settlement Instruction – details* screen >> Click on the *associated penalties* button

**Privileges** To use this screen, you need the following privilege:

- Penalty List Query Privilege
- Settlement Instruction Audit Trail Query

**References** **User Instructions Part**

This screen is part of the following business scenarios:

- View the individual penalty details
- View list of penalties

**Screenshot**

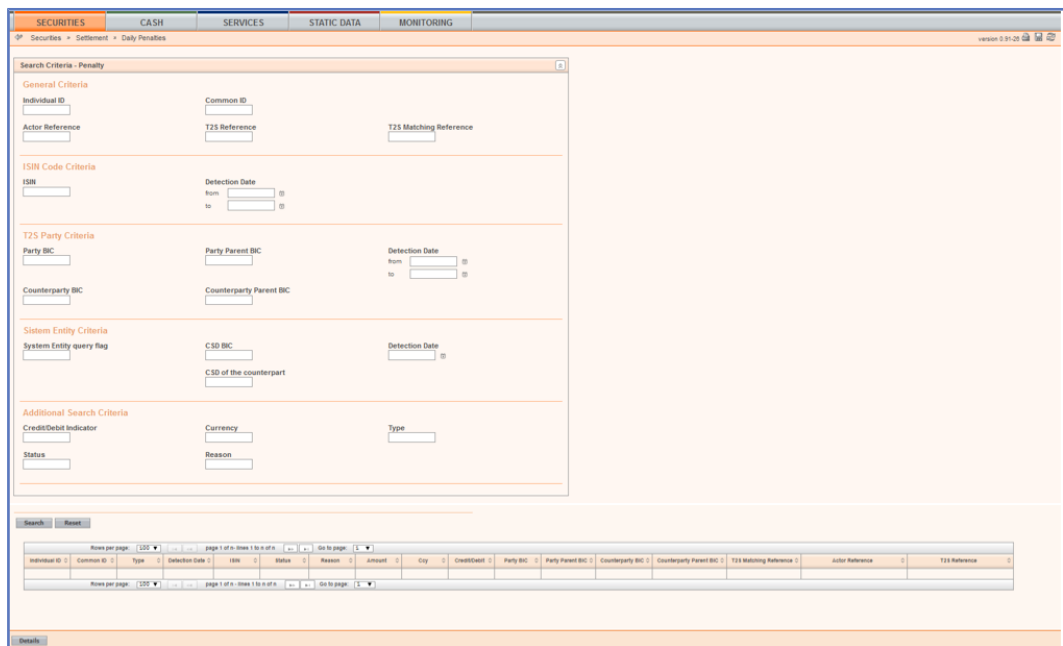

Illustration 62: Penalty – search/list screen

**Field Description**

| Penalty – Search Criteria |  |
|---------------------------|--|
| General Criteria          |  |
| Individual ID             | <p>Enter the individual unique reference assigned to the penalty by T2S for the relevant party.</p> <p>A given penalty can be identified by its individual unique reference assigned by T2S for either the failing or the non-failing party.</p> |

| Penalty – Search Criteria |   |
|---------------------------|---|
|                           | <p>At least one of the reference parameters needs to be specified to perform this query with a reference.</p> <p>This parameter cannot be combined with parameters of any other queries (i.e. parameters in other Groups).</p> <p>Specifying this parameter will return the Penalty - details screen.</p> <p>Required format is: max. 16 characters (SWIFT-x) , no wildcards allowed.</p>   |
| Common ID                 | <p>Enter the common reference assigned to the penalty by T2S.</p> <p>A given penalty can be identified by its common reference assigned by T2S for both the failing and the non-failing party.</p> <p>At least one of the reference parameters needs to be specified to perform this query with a reference.</p> <p>This parameter cannot be combined with parameters of any other queries (i.e. parameters in other Groups).</p> <p>Specifying this parameter will return the Penalty - details screen if only a single penalty is retrieved (because only one of the two individual penalties is under the data scope of the CSD). Otherwise, the screen will return the relevant list of penalties (i.e. two penalties, the penalty as reported for the failing party and the penalty as reported to the non-failing party).</p> <p>Required format is: max. 16 characters (SWIFT-x), no wildcards allowed</p> |
| Actor Reference           | <p>Enter the identification of the settlement instruction assigned by the T2S Actor.</p>  |



| Penalty – Search Criteria |  |
|---------------------------|--|
|                           | <p>Penalties can be identified by the T2S Actor Reference of the underlying settlement instruction.</p> <p>At least one of the reference parameters needs to be specified to perform this query.</p> <p>This parameter cannot be combined with parameters of any other queries (i.e. parameters in other Groups).</p> <p>Specifying this parameter will return the Penalty - details screen if only a single penalty is found, otherwise it will return the relevant list of penalties.</p> <p>Required format is: max. 16 characters (SWIFT-x), no wildcards allowed</p>  |
| T2S Reference             | <p>Enter the identification assigned by T2S to the settlement instruction.</p> <p>Penalties can be identified by the T2S Reference of the underlying settlement instruction.</p> <p>At least one of the reference parameters needs to be specified to perform this query.</p> <p>This parameter cannot be combined with parameters of any other queries (i.e. parameters in other Groups).</p> <p>Specifying this parameter will return the Penalty - details screen if only a single penalty is found, otherwise it will return the relevant list of penalties.</p> <p>Required format is: max. 16 characters (SWIFT-x), no wildcards allowed</p> |
| T2S Matching Reference    | <p>Enter the settlement instruction matching identification assigned by T2S.</p> <p>Penalties can be identified by the T2S Matching Reference of the underlying settlement instruction.</p>  |

| Penalty – Search Criteria                    |  |
|--|--|
|  | <p>At least one of the reference parameters needs to be specified to perform this query.</p> <p>This parameter cannot be combined with parameters of any other queries (i.e. parameters in other Groups).</p> <p>Specifying this parameter will return the Penalty - details screen if only a single penalty is found, otherwise it will return the relevant list of penalties.</p> <p>Required format is: max. 16 characters (SWIFT-x), no wildcards allowed</p>  |
| ISIN Code Criteria                           |  |
| ISIN   | <p>Enter the ISIN of the security relevant for the penalty.</p> <p>This query parameter is mandatory for queries by ISIN Code Criteria.</p> <p>The ISIN must exist in T2S.</p> <p>Required format is: 12 characters (SWIFT-x).</p>   |
| Detection Date (Date from or equal/ Date to) | <p>Enter the specific business day on which the penalty was detected or use the <i>calendar</i> icon.</p> <p>In order to search for a period, enter the lower and the upper bound of the search range for the business day for which the penalty was initially detected or use the calendar icon.</p> <p>Note: This date is not updated upon recalculation of the penalty and always relates to the business day for which the penalty was initially detected.</p> <p>This query parameter is mandatory for queries by ISIN Code Criteria.</p> <p>Required format is: YYYY-MM-DD</p> |
| T2S Party Criteria                           |  |

| Penalty – Search Criteria                    |  |
|--|--|
| Party BIC                                    | <p>You can choose to either enter the 'Party BIC' or to select it from the suggested items in the drop-down menu.</p> <p>The selected BIC corresponds to the party imposed with or entitled to receive the penalty(ies) retrieved by the query.</p> <p>This query parameter is mandatory for queries by T2S Party Criteria.</p> <p>Required format is: max. 11 characters (SWIFT-x)</p>  |
| Party Parent BIC                             | <p>This parameter is mandatory when Party BIC is fulfilled.</p> <p>Field is empty by default. You can select the 'Party Parent BIC' from the suggested items in the drop-down menu, which displays the following values to be input:</p> <ul style="list-style-type: none"><li><input type="checkbox"/> The BIC of the CSD</li><li><input type="checkbox"/> T2S BIC</li></ul> <p>Note: In order to determine the data scope of the query, T2S automatically considers the CSD associated to the user performing the query. Hence, the parameter 'Party Parent BIC' is only relevant to query those penalties where the CSD itself is reported as failing or non-failing party (for which case, the user needs to input the T2S BIC)</p> <p>Required format is: max. 11 characters (SWIFT-x).</p> |
| Detection Date (Date from or equal/ Date to) | <p>Enter the specific business day for which the penalty was detected or use the <i>calendar</i> icon.</p> <p>In order to search for a period, enter the lower and upper bound of the search range for the business day for which the penalty was initially detected or use the <i>calendar</i> icon.</p>  |

| Penalty – Search Criteria |   |
|---------------------------|---|
|                           | <p>Note: This date is not updated upon recalculation of the penalty and always relates to the business day for which the penalty was initially detected.</p> <p>This query parameter is mandatory for queries by T2S Party Criteria.</p> <p>Required format is: YYYY-MM-DD</p>  |
| Counterparty BIC          | <p>You can choose to either enter the 'Counterparty BIC' or to select it from the suggested items in the drop-down menu.</p> <p>The selected BIC corresponds to the counterparty entitled to receive or imposed with the penalty(ies) retrieved by the query.</p> <p>This parameter can be used as search criteria only if the Party BIC is provided.</p> <p>Required format is: max. 11 characters (SWIFT-x)</p>   |
| Counterparty Parent BIC   | <p>You can select the 'Counterparty Parent BIC' from the suggested items in the drop-down menu.</p> <p>The selected BIC corresponds to the parent of the counterparty entitled to receive or imposed with the penalty(ies) retrieved by the query.</p> <p>This parameter is mandatory when Counterparty BIC is fulfilled.</p> <p>Field is empty by default, displays the following values to be input:</p> <ul style="list-style-type: none"> <li><input type="checkbox"/> The BICs of all CSD and the T2S BIC.</li> </ul> <p>Required format is: max. 11 characters (SWIFT-x).</p> |
| System Entity Criteria    |   |

| Penalty – Search Criteria |  |
|---------------------------|--|
| System Entity query flag  | <p>Select if the query desired is a System Entity wide Penalty Query from the possible values:</p> <ul style="list-style-type: none"> <li><input type="checkbox"/> Yes</li> <li><input type="checkbox"/> No (default value)</li> </ul> <p>This parameter is mandatory for queries by System Entity Criteria.</p>   |
| CSD BIC                   | <p>Select the BIC of the CSD whose Participants are imposed with or entitled to receive the penalties retrieved by the query.</p> <p>This parameter is mandatory for queries by System Entity Criteria.</p> <p>If the System Entity query flag = NO, this field is not available.</p> <p>If the System Entity query flag = YES, this field is mandatory and displays the following value:</p> <ul style="list-style-type: none"> <li><input type="checkbox"/> CSD BIC</li> </ul> <p>Required format is: max. 11 characters (SWIFT-x)</p> |
| Detection Date            | <p>Enter the specific business day for which the penalty was detected or use the <i>calendar</i> icon.</p> <p>Note: This date is not updated upon recalculation of the penalty and always relates to the business day for which the penalty was initially detected.</p> <p>This parameter is mandatory for queries by System Entity Criteria.</p> <p>If the System Entity query flag = NO, this field is not available.</p> <p>If the System Entity query flag = YES, this field is mandatory</p> <p>Required format is: YYYY-MM-DD</p>  |

| Penalty – Search Criteria   |   |
|---|---|
| CSD of the counterpart  | <p>Select the BIC of the CSD of the counterparty of the penalty</p> <p>If the System Entity query flag = NO, this field is not available.</p> <p>If the System Entity query flag = YES, this field displays the following values:</p> <ul style="list-style-type: none"> <li><input type="checkbox"/> All (default value)</li> <li><input type="checkbox"/> The BICs of all CSDs</li> </ul> <p>Required format is: max. 11 characters (SWIFT-x)</p> |
| <p><b>Additional Search Criteria</b></p> <p><b>(Use to limit query results of ISIN Code, T2S Party and System Entity Search Criteria)</b></p> |   |
| Credit/Debit Indicator  | <p>Select the Party Credit/Debit Code identifying the party as non-failing or failing from the possible values:</p> <ul style="list-style-type: none"> <li><input type="checkbox"/> All (default value)</li> <li><input type="checkbox"/> DBIT (Debit)</li> <li><input type="checkbox"/> CRDT (Credit)</li> </ul> <p>Required format is: 4 characters (SWIFT-x)</p>   |
| Currency  | <p>Enter the relevant T2S currency of the penalty or use the drop-down menu</p> <p>Possible values:</p> <ul style="list-style-type: none"> <li><input type="checkbox"/> 'All' (default value)</li> <li><input type="checkbox"/> Reference Data Settlement Currencies</li> </ul> <p>Required format is: 3 characters (SWIFT-x)</p>   |
| Type  | <p>Select the type of penalty from the possible values:</p> <ul style="list-style-type: none"> <li><input type="checkbox"/> All (default value)</li> <li><input type="checkbox"/> SEFP (Settlement Fail Penalty)</li> <li><input type="checkbox"/> LMFP (Late Match Fail Penalty)</li> </ul>  |

| Penalty – Search Criteria |   |
|---------------------------|---|
|                           | Required format is: 4 characters (SWIFT-x)  |
| Status                    | <p>Select the status of the penalty from the possible values:</p> <ul style="list-style-type: none"><li><input type="checkbox"/> All (default value)</li><li><input type="checkbox"/> ACTV (Active)</li><li><input type="checkbox"/> REMO (Removed)</li><li><input type="checkbox"/> NCOM (Not computed)</li></ul> <p>Required format is: 4 characters (SWIFT-x)</p>  |
| Reason                    | <p>Select the reason of the penalty status from the possible values:</p> <ul style="list-style-type: none"><li><input type="checkbox"/> All (default value)</li><li><input type="checkbox"/> UPDT (updated)</li><li><input type="checkbox"/> NEWP (New penalty resulting from the insertion of a Security Subject to Penalties with Valid From in the past, or from a contingency scenario)</li><li><input type="checkbox"/> RALO (re-allocated)</li><li><input type="checkbox"/> SWIC (switched)</li><li><input type="checkbox"/> INSO (removed due to insolvency)</li><li><input type="checkbox"/> SESU (removed due to ISIN suspension from SETT)</li><li><input type="checkbox"/> SUSP (removed due to ISIN suspension from trading)</li><li><input type="checkbox"/> SEMP (removed due to settlement on multiple platforms)</li><li><input type="checkbox"/> TECH (removed due to technical impossibilities that prevent settlement)</li><li><input type="checkbox"/> OTHR (removed due to another reason)</li></ul> <p>Required format is: 4 characters (SWIFT-x)</p> |

| Penalty – Search Criteria |  |
|---------------------------|--|
| Penalty - List            |  |
| Individual ID             | Shows the individual unique reference assigned to the penalty by T2S.  |
| Common ID                 | Shows the common reference assigned to the penalty by T2S, which is common for both the failing and the non-failing participant.   |
| Type                      | Shows the type of penalty from the possible values: <ul style="list-style-type: none"><li><input type="checkbox"/> SEFP (Settlement Fail Penalty)</li><li><input type="checkbox"/> LMFP (Late Match Fail Penalty)</li></ul>  |
| Detection Date            | Shows the Business day when the penalty was detected.  |
| ISIN                      | Shows the ISIN of the security used for the penalty calculation.   |
| Status                    | Shows the status of the penalty from the possible values: <ul style="list-style-type: none"><li><input type="checkbox"/> ACTV (Active)</li><li><input type="checkbox"/> REMO (Removed)</li><li><input type="checkbox"/> NCOM (Not computed)</li></ul>  |
| Reason                    | Shows the reason of the penalty status from the possible values: <ul style="list-style-type: none"><li><input type="checkbox"/> Empty (default value)</li><li><input type="checkbox"/> UPDT (updated)</li><li><input type="checkbox"/> NEWP (New penalty resulting from the insertion of a Security Subject to Penalties with Valid From in the past, or from a contingency scenario)</li><li><input type="checkbox"/> RALO (re-allocated)</li><li><input type="checkbox"/> SWIC (switched)</li><li><input type="checkbox"/> INSO (removed due to insolvency)</li><li><input type="checkbox"/> SESU (removed due to ISIN suspension from SETT)</li></ul> |



| Penalty – Search Criteria |  |
|---------------------------|--|
|                           | <ul style="list-style-type: none"><li><input type="checkbox"/> SUSP (removed due to ISIN suspension from trading)</li><li><input type="checkbox"/> SEMP (removed due to settlement on multiple platforms)</li><li><input type="checkbox"/> TECH (removed due to technical impossibilities that prevent settlement)</li><li><input type="checkbox"/> OTHR (removed due to another reason)</li></ul> |
| Amount                    | Shows the amount of the penalty.   |
| Ccy                       | Shows the T2S relevant currency of the amount of the penalty.  |
| Credit/Debit              | Shows the Party Credit/Debit Code identifying the party as non-failing or failing.   |
| Party BIC                 | Shows the BIC of the Party imposed with or entitled to receive the penalties retrieved by the query.   |
| Party Parent BIC          | Shows the BIC of the Parent Party imposed with or entitled to receive the penalties retrieved by the query.  |
| Counterparty BIC          | Shows the BIC of the counterparty entitled to receive or imposed with the amount retrieved by the query.   |
| Counterparty Parent BIC   | Shows the BIC of the parent of the counterparty entitled to receive or imposed with the amount retrieved by the query.   |
| T2S Matching Reference    | Shows the matching identification code assigned by T2S to the related settlement instruction.  |
| Actor Reference           | Shows the identification assigned by the T2S Actor to the related settlement instruction.  |
| T2S Reference             | Shows the instruction identification code assigned by T2S to the related settlement instruction.   |

Note: the above order is the default one provided by T2S as a result of the query. Nevertheless, once the list is displayed in the screen it should be allowed for the user to reorganise the order of the columns in the screen (although in case it is exported, the list is displayed in the original order).

## Buttons

| Buttons |   |
|---------|---|
| Search  | <p>This function enables you to start a search according to the criteria entered. The results are displayed in a list on the next screen, if the search retrieves several records.</p> <p>If the search retrieves a single record, the Penalty - details screen is displayed.</p> <p>Next screens:</p> <ul style="list-style-type: none"> <li><input type="checkbox"/> Penalty - Search/List Screen [▶ 278]</li> <li><input type="checkbox"/> Penalty - Details Screen [▶ 290]</li> </ul> |
| Reset   | <p>This function enables you to set all fields to default value and blanks out all optional fields.</p> <p>Next screen:</p> <ul style="list-style-type: none"> <li><input type="checkbox"/> Penalty - Search/List Screen [▶ 278]</li> </ul>   |
| Details | <p>This function enables you to display the details of the selected penalty.</p> <p>Next screen:</p> <ul style="list-style-type: none"> <li><input type="checkbox"/> Penalty - Details Screen [▶ 290]</li> </ul>  |

### 2.2.2.24 Penalty - Details Screen

#### Context of Usage

This screen displays detailed information on the selected penalty. You can check the data and proceed further by clicking the buttons below.

You can perform the following foreseen actions: check the specific details of a penalty, remove it, re-include it, re-allocate it, switch it, see its revisions/audit trail, and access the details of the underlying settlement instruction.

When exporting the content of this screen, you receive the query result in a csv-file.

This screen is only available for CSD authorised users and T2S Operator user.

This screen will not be available during the processing of penalties, i.e. between the Events “PMSS” (Penalty Mechanism- Stop Screens and penalty modification requests) and “PMRR” (Penalty Mechanism- Restart GUI and Restart processing penalty modification requests).

**Screen  
Access**

- Securities >> Settlement >> Daily Penalties >> Penalty – search/list screen >> Click on the search button
- Securities >> Settlement >> Daily Penalties >> Penalty – search/list screen >> Click on the search button >> Penalty – search/list screen >> Click on the details button
- Securities >> Settlement >> Settlement Instruction >> Settlement instructions – search/list screen >> Click on the search and/or details button >> Settlement Instruction – details screen >> Click on the associated penalties button

**Privileges**

To use this screen, you need the following privilege:

- Penalty Details Query Privilege
- Settlement Instruction Audit Trail Query References

**References****User Instructions Part**

This screen is part of the following business scenarios:

- View the individual penalty details
- Modification of existing penalties
- View settlement instruction details

Screenshot

| SECURITIES  | CASH   | SERVICES  | STATIC DATA | MONITORING |
|---|--|---|-------------|------------|
| <p>Securities &gt; Settlement &gt; Daily Penalties &gt; Penalty Details</p> |  |   |             |            |
| <p><b>Penalty</b></p>   |  |   |             |            |
| <p><b>General Details</b></p>   |  |   |             |            |
| Individual ID<br>F20030300000007  | Common ID<br>20030300000007                  | Re-allocated to/from penalty<br>---   |             |            |
| Party BIC<br>PARBESDPXXX  | Party Parent BIC<br>CSDYESDPXXX              | Credit/Debit Indicator<br>DBIT  |             |            |
| Counterparty BIC<br>CSDYESDPXXX   | Counterparty Parent BIC<br>CSDYESDPXXX       |   |             |            |
| Type<br>SEFP  | Detection Date<br>2020-02-28                 | In Appeal Period<br>NO  |             |            |
| Amount of the penalty<br>---  | To be recalculated<br>NO                     |   |             |            |
| Status<br>NCOM  | Reason<br>---                                | Description<br>---  |             |            |
| Number of Days<br>1   | Calculation Method<br>CASH                   |   |             |            |
| <p><b>Calculation Details</b></p>   |  |   |             |            |
| Date<br>Fri Feb 28 00:00:00 CET 2020  |  |   |             |            |
| Security Subject to Penalties<br>FALSE                                      | Cannot be calculated<br>---                  |   |             |            |
| Financial Instrument Type<br>---  | Liquidity<br>---                             |   |             |            |
| Place of Trade Market Identifier Code<br>---                                | SME Growth Market<br>---                     | Security Penalty Rate<br>---  |             |            |
| Original Currency<br>---  | Euro Foreign Exchange<br>---                 | EURDKK FX (for pivot)<br>---  |             |            |
| Sub-amount Securities<br>---  | Cash Discount Penalty Rate<br>---            | Sub-amount Cash<br>---  |             |            |
| <p><b>Related Settlement Instruction Details</b></p>                        |  |   |             |            |
| Actor Reference<br>C654-ALM-150DAF  | Reference owner BIC<br>PARBESDPXXX           | Reference owner Parent BIC<br>CSDYESDPXXX   |             |            |
| T2S Reference<br>2002190494852167   | T2S Matching Reference<br>0120059917921000   |   |             |            |
| Common Reference<br>C654-ALM-150F   | Corporate Action Event Identification<br>--- |   |             |            |
| Intended Settlement Date<br>2020-02-20                                      | Securities Transaction Type<br>NSYN          | Already Matched Flag<br>NO  |             |            |
| Securities Movement Type<br>Delivery  | ISIN<br>ESES DP200378                        | Quantity<br>---   |             |            |
| Securities Account Number<br>PARBESDPXXXCSDP0001                            | Account Owner BIC<br>---                     | BIC of the Depository<br>---  |             |            |
| Settlement Type<br>Units  |  |   |             |            |
| Payment Type Code<br>APMT   | Credit/Debit<br>CRDT                         | Amount<br>1   |             |            |
| Dedicated Cash Account Number<br>PMBAESDMXXXEURDCA0004                      | DCA Owner BIC<br>---                         |   |             |            |
| Accepted Timestamp<br>2020-02-19 12:28:12.072                               | Matched Timestamp<br>2020-02-19 12:32:40.608 | Failed Reason<br>BLOC SXAA002 Settlement Instruction is not settled because of an intraday restriction on the cash account used by the counterparty<br>ELOC SXAA003 Settlement Instruction is not settled because of an intraday restriction on the securities account used |             |            |
| Cut-off<br>IDVP   | Cut-off Start TS<br>2020-03-02 19:21:52.125  | Cut-off End TS<br>2020-03-02 19:24:30.432   |             |            |
| <p>Removal Re-include Re-allocate Switch Revisions SI Details</p>           |  |   |             |            |

Illustration 63: Penalty - Details Screen UHB

Field Description

| Penalty Details |   |
|-----------------|---|
| General Details |   |
| Individual ID   | Shows the individual unique reference assigned to the penalty by T2S. |

| Penalty Details              |   |
|------------------------------|---|
|                              | <p>A given penalty can be identified by its individual unique reference assigned by T2S for either the failing or the non-failing party.</p>  |
| Common ID                    | <p>Shows the common reference assigned to the penalty by T2S.</p> <p>A given penalty can be identified by its common reference assigned by T2S for both the failing and the non-failing party.</p>  |
| Re-allocated to/from penalty | <p>Shows the Common ID of the penalty re-allocated to/from the penalty retrieved by the query.</p> <p>It will be updated with the new/old Common Id after a re-allocation execution.</p>  |
| Party BIC                    | <p>Shows the BIC of the Party imposed with or entitled to receive the penalty retrieved by the query.</p> <p>The party is the failing or the non-failing party depending on the direction of the penalty.</p>   |
| Party Parent BIC             | <p>Shows the BIC of the Parent Party imposed with or entitled to receive the penalty retrieved by the query.</p>  |
| Credit/Debit Indicator       | <p>Shows the Party Credit/Debit Code identifying the party as non-failing or failing from the possible values:</p> <ul style="list-style-type: none"><li><input type="checkbox"/> CRDT (Credit)</li><li><input type="checkbox"/> DBIT (Debit)</li></ul> |
| Counterparty BIC             | <p>Shows the BIC of the counterparty of the party imposed with or entitled to receive the penalty retrieved by the query.</p> <p>The Counterparty is the failing or the non-failing party depending on the direction of the penalty.</p>                |

| Penalty Details         |  |
|-------------------------|--|
| Counterparty Parent BIC | Shows the BIC of the parent of the counterparty imposed with or entitled to receive the penalty retrieved by the query.  |
| Type                    | Shows the type of penalty from the possible values:<br><input type="checkbox"/> SEFP (Settlement Fail Penalty)<br><input type="checkbox"/> LMFP (Late Match Fail Penalty)  |
| Detection Date          | Shows the business day when the penalty was detected.<br><br>I.e.<br><input type="checkbox"/> The date on which the instruction matched for LMFPs.<br><input type="checkbox"/> The date on which an instruction failed to settle in T2S for SEFPs.<br><br>This date is not updated upon re-calculation of the penalty. |
| In appeal period        | Shows if the penalty is within its appeal period.<br><br>Possible values:<br><input type="checkbox"/> YES<br><input type="checkbox"/> NO   |
| Amount of the penalty   | Shows the amount of the penalty with its T2S relevant currency.  |
| To be recalculated      | Shows if the penalty is pending to be re-calculated after being modified. Possible values:<br><input type="checkbox"/> YES<br><input type="checkbox"/> NO  |
| Status                  | Shows the status of the penalty from the possible values:<br><input type="checkbox"/> ACTV (Active)<br><input type="checkbox"/> REMO (Removed)<br><input type="checkbox"/> NCOM (Not computed)   |

| Penalty Details |   |
|-----------------|---|
|                 | Note: If the status of the penalty is REMO, the attributes of "Calculation Details" are not visible.  |
| Reason          | <p>Shows the reason of the penalty status from the possible values:</p> <ul style="list-style-type: none"><li><input type="checkbox"/> Empty (default value, for new penalties)</li><li><input type="checkbox"/> UPDT (updated)</li><li><input type="checkbox"/> NEWP (New penalty resulting from the insertion of a Security Subject to Penalties with Valid From in the past, or from a contingency scenario)</li><li><input type="checkbox"/> RALO (re-allocated)</li><li><input type="checkbox"/> SWIC (switched)</li><li><input type="checkbox"/> INSO (removed due to insolvency)</li><li><input type="checkbox"/> SESU (removed due to ISIN suspension from SETT)</li><li><input type="checkbox"/> SUSP (removed due to ISIN suspension from trading)</li><li><input type="checkbox"/> SEMP (removed due to settlement on multiple platforms)</li><li><input type="checkbox"/> TECH (removed due to technical impossibilities that prevent settlement)</li><li><input type="checkbox"/> OTHR (removed due to another reason)</li></ul> |
| Description     | Shows the reason for the removal (when the status of the penalty is 'Removed' and the reason is 'OTHR') and for the switch (when the status of the penalty is 'Active' and the reason is 'SWIC') as provided by the CSD when the penalty modification was requested.  |
| Number of Days  | The value is 1 always in case of 'SEFP'.  |

| Penalty Details  |  |
|--|--|
|  | Shows the number of business days used for the calculation of the penalty in case of 'LMFP'.   |
| Calculation Method   | <p>Shows the calculation rule used to compute the penalty from the possible values:</p> <ul style="list-style-type: none"> <li><input type="checkbox"/> SECU (The penalty is based on the quantity of securities failed to be delivered and penalty rate of the relevant asset type).</li> <li><input type="checkbox"/> MIXE (The penalty is based on the quantity of securities failed to be delivered and penalty rate is the discount rate of the relevant currency).</li> <li><input type="checkbox"/> CASH (The penalty is based on the amount of cash failed to be delivered and the penalty rate is the discount rate of the relevant currency).</li> <li><input type="checkbox"/> BOTH (The penalty is the sum of SECU and CASH).</li> </ul> |
| <p><b>Calculation Details</b></p> <p>Block with the details for any of the applicable Business Days considered in the computation of the penalty</p> <p>The block is not shown in case the penalty is Removed.</p> |  |
| Date   | <p>Shows the Business Day for the data provided in this block.</p> <p>When "Number of Days" = 1 this field will be displayed as a text (i.e. the date of the penalty is displayed)</p> <p>When "Number of Days"&gt;1 it will display a list with all the applicable Business Days (i.e. when there is a sub-amount).</p>   |



| Penalty Details               |  |
|-------------------------------|--|
|                               | <p>The order of the list will be descending (i.e. first value of the list will be the Closest Business Day to the current Business day).</p> <p>Limit: The user can only select (to see the Calculation Details) dates within the last 3 months. Former days (before 3 months) have the same Calculation Details than the ones for the Date equal to 3 months ago.</p>                           |
| Security Subject to Penalties | <p>Shows if the security is subject to penalties on the business day. Possible values:</p> <ul style="list-style-type: none"><li><input type="checkbox"/> TRUE (default)</li><li><input type="checkbox"/> FALSE</li></ul> <p>It will be shown the information corresponding to the date chosen in the field DATE.</p> <p>If no value is retrieved, it will show "---"</p>                        |
| Cannot be calculated          | <p>This information is only provided for penalties where there is missing or diverging reference data needed for the penalty calculation.</p> <p>Possible values:</p> <ul style="list-style-type: none"><li><input type="checkbox"/> Empty (default). If value is FALSE in the data base or if no value is retrieved, it will show empty ("---")</li><li><input type="checkbox"/> TRUE</li></ul> |
| Reason for not calculation    | <p>Shows the reason why the Penalty cannot be calculated.</p> <p>Only shown if the Cannot be calculated field is TRUE.</p>   |
| Financial Instrument Type     | <p>Shows the type of the financial instrument from the possible values:</p> <ul style="list-style-type: none"><li><input type="checkbox"/> SHRS</li><li><input type="checkbox"/> SOVR</li></ul>  |

| Penalty Details                       |   |
|---------------------------------------|---|
|                                       | <ul style="list-style-type: none"> <li><input type="checkbox"/> DEBT</li> <li><input type="checkbox"/> SECU</li> <li><input type="checkbox"/> ETFS</li> <li><input type="checkbox"/> UCIT</li> <li><input type="checkbox"/> MMKT</li> <li><input type="checkbox"/> EMAL</li> <li><input type="checkbox"/> OTHR</li> </ul> <p>It will be shown the information corresponding to the date chosen in the field DATE.</p> <p>If no value is retrieved, it will show "---"</p>   |
| Liquidity                             | <p>Shows the binary classification of securities applying for shares.</p> <p>It will show the information corresponding to the date chosen in the field DATE.</p> <p>Possible values:</p> <ul style="list-style-type: none"> <li><input type="checkbox"/> Empty ("---")</li> <li><input type="checkbox"/> TRUE</li> <li><input type="checkbox"/> FALSE</li> </ul> <p>Informed only if:</p> <ul style="list-style-type: none"> <li><input type="checkbox"/> The Security is Subject to penalties</li> <li><input type="checkbox"/> The Financial Instrument Type of the security (Classification type) is "SHRS", and</li> <li><input type="checkbox"/> The Calculation method code is "SECU" or "BOTH".</li> </ul> <p>Otherwise it is empty.</p> <p>If no value is retrieved, it will also show "---"</p> |
| Place of Trade Market Identifier Code | <p>Shows the Market identifier Code when it was informed equally in the Place of Trade of the two matched Settlement Instructions. If it was not informed equally, the field will be empty.</p>   |

| Penalty Details       |   |
|-----------------------|---|
|                       | If no value is retrieved, it will show "---"  |
| SME Growth Market     | <p>Shows if the Place of Trade (MIC) is in the list of recognised SME Growth Markets Trading Venues.</p> <p>It will show the information corresponding to the date chosen in the field DATE.</p> <ul style="list-style-type: none"><li><input type="checkbox"/> Possible values:</li><li><input type="checkbox"/> Empty ("---")</li><li><input type="checkbox"/> TRUE</li><li><input type="checkbox"/> FALSE</li></ul> <p>Informed only if:</p> <ul style="list-style-type: none"><li><input type="checkbox"/> The Security is Subject to penalties</li><li><input type="checkbox"/> The Financial Instrument Type of the security (Classification type) is different from "SOVR", and</li><li><input type="checkbox"/> The Calculation method code is "SECU" or "BOTH".</li></ul> <p>Otherwise it is empty.</p> <p>If no value is retrieved, it will also show "---"</p> |
| Security Penalty Rate | <p>Shows the security penalty rate that based on the asset type was used for the calculation of the penalty.</p> <p>It will show the information corresponding to the date chosen in the field DATE.</p> <p>Informed when the calculation method is "SECU" or "BOTH". Otherwise it is empty.</p> <p>If no value is retrieved, it will show "---"</p>  |
| Original Currency     | Shows the currency of the reference price (i.e. when the security is in Unit) or of the reference security (i.e when the security is in FAMT) of the Settlement Instruction.  |

| Penalty Details            |   |
|----------------------------|---|
|                            | <p>It will show the information corresponding to the date chosen in the field DATE.</p> <p>If no value is retrieved, it will show "---"</p>   |
| Euro Foreign Exchange      | <p>Shows the Euro Foreign Exchange unit and currency used for the computation of the penalty, when necessary.</p> <p>It will show the information corresponding to the date chosen in the field DATE.</p> <p>If no value is retrieved, it will show "---"</p>   |
| EURDKK FX (for pivot)      | <p>Shows the second Euro Foreign Exchange unit and currency used as pivot for the computation of the penalty, when necessary.</p> <p>It will show the information corresponding to the date chosen in the field DATE.</p> <p>If no value is retrieved, it will show "---"</p>   |
| Sub-amount Securities      | <p>Shows the amount of the penalty for this business day and its T2S relevant currency.</p> <p>It is only provided if the number of days is higher than one (i.e. when it is a LMFP and the block calculation details has more than one instance) or if the calculation method is BOTH (in this case Sub-amount cash is also provided).</p> <p>It will show the information corresponding to the date chosen in the field DATE.</p> <p>If no value is retrieved, it will show "---"</p> |
| Cash Discount Penalty Rate | <p>Shows the currency discount penalty rate used for the computation of the penalty.</p>  |

| Penalty Details                        |   |
|--|---|
|  | <p>Informed when the calculation method is MIXE, CASH or BOTH. Otherwise it is empty.</p> <p>It will show the information corresponding to the date chosen in the field DATE.</p> <p>If no value is retrieved, it will show "---"</p>   |
| Sub-amount Cash                        | <p>Shows the amount of the penalty for this business day and its T2S relevant currency.</p> <p>It is only provided if the number of days is higher than one (i.e. when it is a LMFP and the block calculation details has more than one instance) or if the calculation method is BOTH (in this case also Sub-amount securities is provided).</p> <p>It will show the information corresponding to the date chosen in the field DATE.</p> <p>If no value is retrieved, it will show "---"</p> |
| Related Settlement Instruction Details |   |
| Actor Reference                        | Shows the identification assigned by the T2S Actor to the related settlement instruction.   |
| Reference Owner BIC                    | Shows the BIC of the Instructing Party of the settlement instruction.   |
| Reference Owner Parent BIC             | Shows the Parent BIC of the Instructing Party of the settlement instruction.  |
| T2S Reference                          | Shows the instruction identification code assigned by T2S to the related settlement instruction.  |
| T2S Matching Reference                 | Shows the matching identification code assigned by T2S to the related settlement instruction.   |

| Penalty Details             |   |
|-----------------------------|---|
| Common Reference            | Shows the reference provided by the T2S Actor when the LCMM Instruction is already matched or in order to facilitate the matching within T2S.   |
| Corporate Action Event Id   | Shows the identification assigned by the account servicer to unambiguously identify a corporate action event.   |
| Intended Settlement Date    | Shows the date when the settlement instruction becomes eligible to be submitted to settlement.<br>Displayed format is: YYYY-MM-DD   |
| Securities Transaction Type | Shows the securities transaction type expressed as an ISO 20022 code from the possible values: <ul style="list-style-type: none"><li><input type="checkbox"/> AUTO (for auto-collateralisation)</li><li><input type="checkbox"/> BSBK (for buy sell back)</li><li><input type="checkbox"/> BYIY (for buy-in)</li><li><input type="checkbox"/> CLAI (for market claim)</li><li><input type="checkbox"/> CNCB (for central bank collateral operation)</li><li><input type="checkbox"/> COLI (for collateral in)</li><li><input type="checkbox"/> COLO (for collateral out)</li><li><input type="checkbox"/> CONV (for depository receipt conversion)</li><li><input type="checkbox"/> CORP (for corporate action)</li><li><input type="checkbox"/> ETFT (for exchange traded funds)</li><li><input type="checkbox"/> FCTA (for factor update)</li><li><input type="checkbox"/> INSP (for move of stock)</li><li><input type="checkbox"/> ISSU (for depository receipt issue)</li><li><input type="checkbox"/> MKDW (for mark down)</li><li><input type="checkbox"/> MKUP (for mark up)</li><li><input type="checkbox"/> NETT (for netting)</li><li><input type="checkbox"/> NSYN (for non syndicated)</li><li><input type="checkbox"/> OWNE (for external account transfer)</li></ul> |

| Penalty Details      |   |
|----------------------|---|
|                      | <ul style="list-style-type: none"> <li><input type="checkbox"/> OWNI (for internal account transfer)</li> <li><input type="checkbox"/> PAIR (for pair off)</li> <li><input type="checkbox"/> PLAC (for placement)</li> <li><input type="checkbox"/> PORT (for portfolio move)</li> <li><input type="checkbox"/> REAL (for realignment)</li> <li><input type="checkbox"/> REBL (Rebalancing)</li> <li><input type="checkbox"/> REDI (for withdrawal)</li> <li><input type="checkbox"/> REDM (for redemption)</li> <li><input type="checkbox"/> RELE (for depository receipt release cancellation)</li> <li><input type="checkbox"/> REPU (for repo)</li> <li><input type="checkbox"/> RODE (for return delivery without matching)</li> <li><input type="checkbox"/> RVPO (for reverse repo )</li> <li><input type="checkbox"/> SBBK (for sell buy back)</li> <li><input type="checkbox"/> SBRE (for borrowing reallocation)</li> <li><input type="checkbox"/> SECB (for securities borrowing)</li> <li><input type="checkbox"/> SECL (for securities lending)</li> <li><input type="checkbox"/> SLRE (for lending reallocation)</li> <li><input type="checkbox"/> SUBS (for subscription)</li> <li><input type="checkbox"/> SWIF (Switch From)</li> <li><input type="checkbox"/> SWIT (Switch To)</li> <li><input type="checkbox"/> SYND (for syndicate underwriters)</li> <li><input type="checkbox"/> TBAC (for TBA closing)</li> <li><input type="checkbox"/> TRAD (for trade)</li> <li><input type="checkbox"/> TRPO (for triparty repo)</li> <li><input type="checkbox"/> TRVO (for triparty reverse repo)</li> <li><input type="checkbox"/> TURN (for turnaround)</li> </ul> |
| Already Matched Flag | <p>Shows if the settlement instruction was sent as already matched to T2S or not (for LMFP). Possible values:</p> <ul style="list-style-type: none"> <li><input type="checkbox"/> YES</li> <li><input type="checkbox"/> NO</li> </ul>   |

| Penalty Details           |  |
|---------------------------|--|
| Securities Movement Type  | Shows if the movement on a securities account results from a deliver or a receive instruction from the possible values:<br><input type="checkbox"/> DELI (for deliver)<br><input type="checkbox"/> RECE (for receive)        |
| ISIN                      | Shows the ISIN code of the security.   |
| Quantity                  | Shows the remaining quantity of the underlying Settlement Instruction used for the calculation of the SEFP.<br>Shows the matched quantity of the underlying Settlement Instruction used for the calculation of the LMFP      |
| Securities Account Number | Shows the account to or from which a securities entry is made.   |
| Account Owner BIC         | Shows the BIC of the Securities Account owner.   |
| BIC of the Depository     | Shows the BIC of the CSD of the Securities Account Owner.<br>It is filled only in case of LMFP. Otherwise, it will show "---".   |
| Settlement Type           | Shows the type of settlement foreseen for the security, stated in the instruction.<br>Possible values:<br><input type="checkbox"/> Units<br><input type="checkbox"/> Face Amount   |
| Payment Type Code         | Shows if the transaction is to be settled with or without payment from the possible values:<br><input type="checkbox"/> APMT (for 'Against Payment Settlement')<br><input type="checkbox"/> FREE (for 'Separate Settlement') |



| Penalty Details               |   |
|-------------------------------|---|
| Credit/Debit                  | Shows if the original settlement amount is to be credited or debited. from the possible values:<br><input type="checkbox"/> DBIT (Debit)<br><input type="checkbox"/> CRDT (Credit)  |
| Amount                        | Shows the remaining amount of the underlying Settlement Instruction used for the calculation of the SEFP.<br>Shows the matched amount of the underlying Settlement Instruction used for the calculation of the LMFP.<br>This field also shows the T2S relevant currency of the amount of the instruction. |
| Dedicated Cash Account Number | Shows the cash account stated in the settlement instruction (only in case of settlement instructions against payment).  |
| DCA Owner BIC                 | Shows the BIC of the owner of the cash account stated in the settlement instruction (only in case of settlement instructions against payment).  |
| Accepted Timestamp            | Shows the accepted timestamp of the settlement instruction.   |
| Matched Timestamp             | Shows the matched timestamp of the settlement instruction.  |
| Failed Reason                 | Shows the reason for the instruction not being fully settled at the end of the processing of its cut-off (for SEFP)   |
| Cut-off                       | Shows the relevant cut-off considered in the calculation of the penalty (for SEFP).   |
| Cut-off Start TS              | Shows the start time of execution of the relevant cut-off (for SEFP).   |
| Cut-off End TS                | Shows the end time of execution of the relevant cut-off (for SEFP).   |

**Buttons**

| Buttons    |   |
|------------|---|
| Removal    | <p>This function enables you to remove existing penalties.</p> <p>This button will only be available if the Penalty:</p> <ul style="list-style-type: none"> <li><input type="checkbox"/> has status 'Active' (ACTV)</li> <li><input type="checkbox"/> is a 'Debit'</li> <li><input type="checkbox"/> is in its appeal period (i.e. "In appeal period" is "Yes")</li> </ul> <p>By clicking this button the d [▶ 314] will pop up with the relevant information to create a Removal Request based on the Penalty of the screen.</p>   |
| Re-include | <p>This function enables you to re-include penalties with status 'Removed' and reason different from 'Re-allocated'. Upon clicking on the Re-include button you will be asked to enter your PIN for digital signature purposes (NRO). With the entry of the PIN, T2S attaches a digital signature to the modification request entered by the T2S actor.</p> <ul style="list-style-type: none"> <li><input type="checkbox"/> This button will only be available if the Penalty;</li> <li><input type="checkbox"/> has status 'Removed' (REMO)</li> <li><input type="checkbox"/> is a 'Debit'</li> <li><input type="checkbox"/> is in its appeal period (i.e. "In appeal period" is Yes)</li> </ul> <p>By clicking this button the Confirmation prompt will pop-up. Hence, the action is triggered (i.e. the Re-inclusion Request is sent) and the Penalty - details screen is displayed again:</p> <ul style="list-style-type: none"> <li><input type="checkbox"/> Either updated (i.e. Penalty with new status ACTV, (Active), new Reason Code UPDT (Updated) and description (if applies), penalty amount and Calculation details be-</li> </ul> |

|                    |   |
|--------------------|---|
|                    | <p>for the penalty was removed and the flag To be recalculated set to YES) if the Re-inclusion Request is confirmed and executed (the action was triggered in Two-eyes);</p> <ul style="list-style-type: none"> <li><input type="checkbox"/> Or not updated if:             <ul style="list-style-type: none"> <li><input type="checkbox"/> the Re-inclusion Request is Validated and Awaiting for Approval (the action was triggered in Four-eyes and the Penalty - details screen shows the ID for the action awaiting for approval)</li> <li><input type="checkbox"/> the Re-inclusion Request is rejected shows the reason for rejecting the action).</li> </ul> </li> </ul> <p>References for error messages:</p> <ul style="list-style-type: none"> <li><input type="checkbox"/> PMMO010</li> <li><input type="checkbox"/> PMMO016</li> <li><input type="checkbox"/> PMMO031</li> <li><input type="checkbox"/> PMMO032</li> </ul> |
| <p>Re-allocate</p> | <p>This function enables you to re-allocate existing penalties if they are LMFP over a Settlement Instruction sent as already matched to T2S.</p> <p>This button will only be available if :</p> <ul style="list-style-type: none"> <li><input type="checkbox"/> The status of the penalty is "Active"</li> <li><input type="checkbox"/> It is a LMFP</li> <li><input type="checkbox"/> The LMFP has not been re-allocated before (i.e. "Re-allocated to/from penalty" is empty)</li> <li><input type="checkbox"/> Underlying settlement instruction was sent as already matched to T2S (i.e. "Already Matched Flag" is Yes)</li> </ul>   |

|            |   |
|------------|---|
|            | <ul style="list-style-type: none"> <li><input type="checkbox"/> The penalty is still in its appeal period (i.e. "In appeal period" is Yes)</li> </ul> <p>By clicking this button the Penalty re-allocation screen will pop-up with the relevant information to create a Re-allocation Request based on the Penalty of the screen.</p>   |
| Switch     | <p>This function enables you to switch the failing party and non-failing party of existing penalties.</p> <p>This button will only be available if the Penalty:</p> <ul style="list-style-type: none"> <li><input type="checkbox"/> has status 'Active' (ACTV)</li> <li><input type="checkbox"/> is a 'Debit'</li> <li><input type="checkbox"/> is in its appeal period (i.e. "In appeal period" is Yes)</li> </ul> <p>By clicking this button the Penalty switch screen will pop-up with the relevant information to create a Switch Request based on the Penalty of the screen.</p> |
| Revisions  | <p>This function enables you to display the revisions of the selected penalty.</p> <p>Next screen:</p> <ul style="list-style-type: none"> <li><input type="checkbox"/> Revisions/Audit Trail - list Screen [▶ 661]</li> </ul>   |
| SI Details | <p>This function enables you to display the details of the relevant settlement instruction.</p> <p>Next screen:</p> <ul style="list-style-type: none"> <li><input type="checkbox"/> Settlement Instruction - details Screen</li> </ul>  |

## 2.2.2.25 Monthly Net Penalty Amounts - Search/List Screen

### Context of Usage

This screen contains a number of search fields. By inputting the relevant data, you can search for monthly net amounts for the penalties computed by T2S for the business days of a previous month, for a given T2S Party and counterpart(s).

The query allows to search per currency, party and counterparty.

This screen will only return results where the relevant CSD has the right to access the underlying data (i.e. party is in its data scope).

The search results will be displayed in a list when more than one result is retrieved by T2S.

When only one result is retrieved, the relevant aggregated amount resulting from the query will be displayed in the same format used by the list screen.

The monthly net amounts of a particular month will be available only once T2S has produced the Monthly reporting of aggregated amounts of cash penalties for that month.

When exporting the content of this screen, you receive the query result in a csv-file.

This screen is only available for CSD authorised users and T2S Operator user.

### Screen Access

Securities >> Settlement >> Monthly Penalties >> *Monthly Net Penalty Amounts – Search/List* screen

### Privileges

To use this screen, you need the following privilege:

Monthly Net Penalty Amount Query Privilege

### References

#### User Instructions Part

This screen is part of the following business scenarios:

View monthly net amounts of penalties

Screenshot

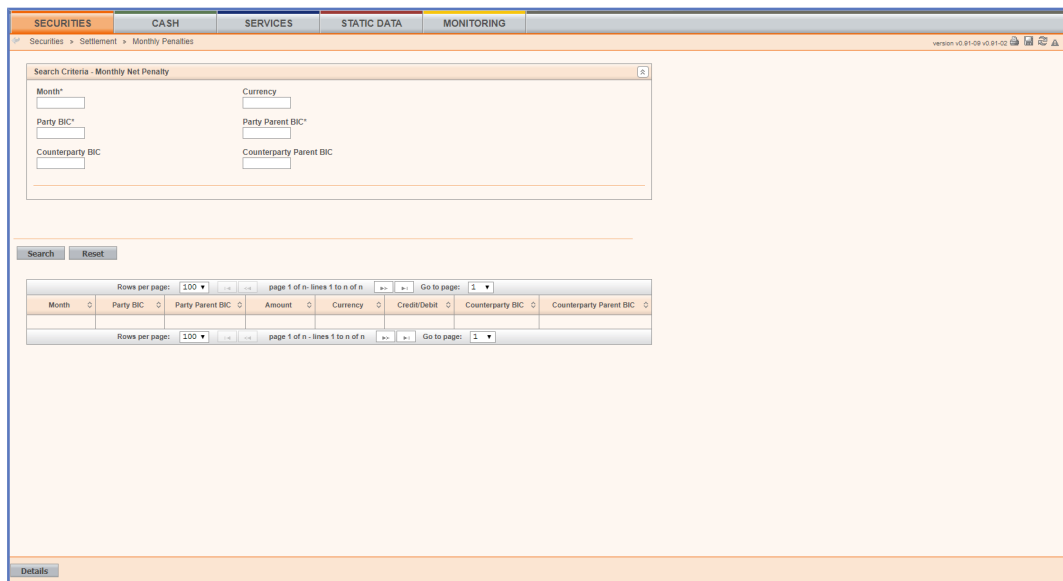

Illustration 64: Monthly net penalty amounts – search/list screen

Field Description

| Monthly Net Penalty Amount – Search Criteria |  |
|--|--|
| Month  | <p>Enter the relevant month you search for or select it from the drop-down menu.</p> <p>Only the past 3 months will be available.</p> <p>This parameter is mandatory for queries by Search Criteria.</p> <p>Required format is: YYYY-MM</p>  |
| Currency                                     | <p>Enter the relevant T2S currency of the monthly net penalty amount or use the drop-down menu.</p> <p>The default value is 'All'.</p> <p>Required format is: 3 characters (SWIFT-x)</p>   |
| Party BIC                                    | <p>You can choose to either enter the 'Party BIC' or to select it from the suggested items in the drop-down menu.</p> <p>The selected BIC corresponds to the party imposed with or entitled to receive the amount retrieved by the query.</p> <p>This parameter is mandatory for queries by Search Criteria.</p> <p>Required format is: max. 11 characters (SWIFT-x)</p> |

| Monthly Net Penalty Amount – Search Criteria |   |
|--|---|
| Party Parent BIC                             | <p>You can select the ‘Party Parent BIC’ from the suggested items in the drop-down menu.</p> <p>The selected BIC corresponds to the parent of the party imposed with or entitled to receive the amount retrieved by the query.</p> <p>This parameter is mandatory for queries by Search Criteria.</p> <p>In order to determine the data scope of the query, T2S automatically considers the CSD associated to the user performing the query. Hence, the parameter ‘Party Parent BIC’ is only relevant to query those amounts where the CSD itself is reported as failing or non-failing party(for which case, the user needs to input the T2S BIC).</p> <p>Field is empty by default and displays the following values to be input:</p> <ul style="list-style-type: none"> <li><input type="checkbox"/> CSD BIC</li> <li><input type="checkbox"/> T2S BIC</li> </ul> <p>Required format is: max. 11 characters (SWIFT-x).</p> |
| Counterparty BIC                             | <p>You can choose to either enter the ‘Counterparty BIC’ or to select it from the suggested items in the drop-down menu.</p> <p>The selected BIC corresponds to the counterparty entitled to receive or imposed with the amount retrieved by the query.</p> <p>Required format is: max. 11 characters (SWIFT-x).</p>  |
| Counterparty Parent BIC                      | <p>You can select the ‘Counterparty Parent BIC’ from the suggested items in the drop-down menu.</p>   |

| Monthly Net Penalty Amount – Search Criteria |   |
|--|---|
|  | <p>The selected BIC corresponds to the parent of the counterparty entitled to receive or imposed with the amount retrieved by the query.</p> <p>This parameter can be used as search criteria only if the Counterparty BIC is introduced. Hence, this parameter is mandatory when Counterparty BIC is fulfilled.</p> <p>This field displays the BICs of all CSD and the T2S BIC.</p> <p>Required format is: max. 11 characters (SWIFT-x).</p> |
| Monthly Net Penalty Amount – List            |   |
| Month  | <p>Shows the relevant month for the amount calculation.</p> <p>Only the aggregated amounts for the past 3 months will be available.</p>   |
| Party BIC                                    | Shows the 'Party BIC' of the party imposed with or entitled to receive the amount retrieved by the query.   |
| Party Parent BIC                             | Shows the 'Party Parent BIC' of the party imposed with or entitled to receive the amount retrieved by the query.  |
| Amount                                       | <p>Shows the monthly net amount retrieved by the query and equal to:</p> <ul style="list-style-type: none"> <li><input type="checkbox"/> The sum of all penalties of the relevant month in the relevant currency and that this party is entitled to receive (reported as credit) from the same counterpart (i.e. to be paid by this counterpart);</li> </ul> <p>Minus</p>   |



| Monthly Net Penalty Amount – Search Criteria |   |
|--|---|
|  | <input type="checkbox"/> The sum of all penalties of the relevant month in the relevant currency, that were imposed to this party (reported as debit), and to be paid to a given counterpart.   |
| Currency                                     | Shows the relevant T2S currency of the monthly net penalty amount.  |
| Credit/Debit                                 | Shows the Credit/Debit Code identifying the monthly net amount as to be debited or credited to the party. Possible values: <ul style="list-style-type: none"> <li><input type="checkbox"/> DBIT (Debit)</li> <li><input type="checkbox"/> CRDT (Credit)</li> </ul> Note: If the amount is equal to zero, this field is empty. |
| Counterparty BIC                             | Shows the 'Counterparty Party BIC' of the party imposed with or entitled to receive the amount retrieved by the query.  |
| Counterparty Parent BIC                      | Shows the 'Counterparty Parent BIC' of the party imposed with or entitled to receive the amount retrieved by the query.   |

**Buttons**

| Buttons |   |
|---------|---|
| Search  | This function enables you to start a search according to the criteria entered. The results are displayed on the list screen. <p>Next screens:</p> <ul style="list-style-type: none"> <li><input type="checkbox"/> Monthly Net Penalty Amounts – search/list screen</li> </ul> |
| Reset   | This function enables you to set all fields to default value and blanks out all optional fields. <p>Next screen:</p>  |

- Monthly Net Penalty Amounts – search/list screen

## 2.2.2.26 Penalty - Removal Screen

### Context of Usage

This screen is accessible by clicking on the “Remove” button of the Penalty – details screen. This action triggers a pop up screen (the Penalty removal screen) that allows entering relevant information to remove the penalty (i.e. the individual Id of the penalty, a drop-down menu to select the reason code and also a text box to insert a description text if the reason selected is OTHR). The confirmation will be completed after clicking on the “Submit” button.

This function is available if the status of the penalty is “Active”, it is a debit and it is still in the appeal period.

The Penalty removal screen is linked to the related Penalty - details screen.

This screen is only available for CSD authorised users and T2S Operator user.

This screen will not be available during the processing of penalties, i.e. between the Events “PMSS” (Penalty Mechanism- Stop Screens and penalty modification requests) and “PMRR” (Penalty Mechanism- Restart GUI and Restart processing penalty modification requests).

### Screen Access

- Securities >> Settlement >> Daily Penalties >> *Penalty – search/list* screen >> Click on the *search* button >> *Penalty – details* screen >> Click on the *removal* button
- Securities >> Settlement >> Daily Penalties >> *Penalty – search/list* screen >> Click on the *search* button >> *Penalty – search/list* screen >> Click on the *details* button >> *Penalty – details* screen >> Click on the *removal* button
- Securities >> Settlement >> Settlement Instruction >> *Settlement instructions – search/list* screen >> Click on the *search* and/or *details* button >> *Settlement Instruction – details* screen >> Click on the *associated penalties* button >> *Penalty – details* screen >> Click on the *removal* button

### Privileges

To use this screen, you need the following privilege:

- Penalty Details Query Privilege
- Settlement Instruction Audit Trail Query
- Modification of penalties

### References

#### User Instructions Part

This screen is part of the following business scenarios:

- Modification of existing penalties

- View the individual penalty details

**Screenshot**

Illustration 65: Penalty – removal screen

**Field**

**Description**

| Penalty Removal |  |
|-----------------|--|
| Individual ID   | Shows the individual unique reference assigned to the penalty by T2S.<br><br>This attribute is passed from previous screen.  |
| Reason          | Selects the reason for the removal of the penalty from the possible values: <ul style="list-style-type: none"> <li><input type="checkbox"/> INSO (removed due to insolvency)</li> <li><input type="checkbox"/> SESU (removed due to ISIN suspension from SETT)</li> <li><input type="checkbox"/> SUSP (removed due to ISIN suspension from trading)</li> <li><input type="checkbox"/> SEMP (removed due to settlement on multiple platforms)</li> <li><input type="checkbox"/> TECH (removed due to technical impossibilities that prevent settlement)</li> <li><input type="checkbox"/> OTHR (removed due to another reason)</li> </ul> |
| Description     | A free text box to insert a description text if the reason selected is "OTHR".<br><br>Therefore, description must be fulfilled if the Reason Code is OTHR, otherwise it must be blank.   |

**Buttons****Submit**

This function enables you to complete the Removal Request of the penalty. Upon clicking on the submit button you will be asked to enter your PIN for digital signature purposes (NRO). With the entry of the PIN, T2S attaches a digital signature to the modification request entered by the T2S actor.

When the button is clicked, the pop up is closed and the Penalty – details screen is displayed again as follows:

- Either displayed updated (i.e. Penalty with new status REMO, the corresponding Reason Code and description (if applies), the penalty amount reduced to zero and Calculation Details no longer visible) if the Removal Request is confirmed and executed (the action was triggered in Two-eyes);
- Or not updated if the Removal Request is Validated and Awaiting for Approval (the action was triggered in Four-eyes and the Penalty - details screen shows the ID for the action awaiting for approval).

When the Removal Request is rejected the pop up is closed and the Penalty – details screen is displayed not updated (with the previous values) but showing the reason for rejecting the action.

Next screen:

- Penalty - Details Screen [▶ 290]

References for error messages:

- PMMO010
- PMMO016
- PMMO030

|        |   |
|--------|---|
| Cancel | <p>This function enables you to get back to the previous screen without removing the penalty.</p> <p>When Penalty – details screen is displayed again, it should be displayed not updated (with the previous values, i.e. still as an active penalty).</p> <p>Next screen:</p> <ul style="list-style-type: none"> <li><input type="checkbox"/> Penalty - Details Screen [ 290]</li> </ul> |
|--------|---|

### 2.2.2.27 Penalty - Re-allocation Screen

#### Context of Usage

This screen is accessible by clicking on the “Re-allocate” button of the Penalty - details screen. This action triggers a pop up screen (the Penalty re-allocation screen) that allows entering the relevant information, to re-allocate the penalty. The confirmation will be completed after clicking on the “Submit” button.

This function is available if the status of the penalty is “Active”, the penalty is a LMFP and the LMFP has not been reallocated before. Furthermore, the underlying instruction must have been sent as already matched to T2S and the penalty must be still in its appeal period.

The Penalty re-allocation screen is linked to the related Penalty – details screen.

This screen is only available for CSD authorised users and T2S Operator user.

This screen will not be available during the processing of penalties, i.e. between the Events “PMSS” (Penalty Mechanism- Stop Screens and penalty modification requests) and “PMRR” (Penalty Mechanism- Restart GUI and Restart processing penalty modification requests).

#### Screen Access

- Securities >> Settlement >> Daily Penalties >> *Penalty – search/list* screen >> Click on the *search* button >> *Penalty – details* screen >> Click on the *re-allocation* button
- Securities >> Settlement >> Daily Penalties >> *Penalty – search/list* screen >> Click on the *search* button >> *Penalty – search/list* screen >> Click on the *details* button >> *Penalty – details* screen >> Click on the *re-allocation* button
- Securities >> Settlement >> Settlement Instruction >> *Settlement instructions – search/list* screen >> Click on the *search* and/or *details* button >> *Settlement Instruction – details* screen >> Click on the *associated penalties* button >> *Penalty – details* screen >> Click on the *re-allocation* button

**Privileges** To use this screen, you need the following privilege:

- Penalty Details Query Privilege
- Settlement Instruction Audit Trail Query
- Modification of penalties

**References** **User Instructions Part**

This screen is part of the following business scenarios:

- Modification of existing penalties
- View the individual penalty details

**Screenshot**



Illustration 66: Penalty – re-allocation screen

**Field**

**Description**

| Penalty Re-allocation     |   |
|---------------------------|---|
| Common ID                 | Shows the common reference assigned to the penalty by T2S, which is common for both the failing and the non-failing participant. This attribute is passed from previous screen.   |
| <b>New Parties</b>        |   |
| New Failing Party BIC     | <p>BIC of the Party that will become the failing party of the penalty after the re-allocation.</p> <p>Possible values are the BICs of the underlying Settlement Instruction, as follows:</p> <ul style="list-style-type: none"> <li><input type="checkbox"/> The BIC of the T2S Delivering Party</li> <li><input type="checkbox"/> The BIC of the T2S Receiving Party</li> </ul> <p>References for error messages:</p> <ul style="list-style-type: none"> <li><input type="checkbox"/> PMMO021</li> <li><input type="checkbox"/> PMMO023</li> </ul> |
| New Non-Failing Party BIC | BIC of the non-failing party of the penalty.  |

| Penalty Re-allocation                           |   |
|---|---|
|   | This field is fulfilled automatically with the other value (BIC) not chosen/selected for the New Failing Party BIC.   |
| T2S Reference of Failing Settlement Instruction | <p>Instruction identification code assigned by T2S to the related settlement instruction.</p> <p>It must be provided in case the two BICs retrieved for the New failing Party BIC are the same</p> <p>Otherwise, it must be blank.</p> <p>References for error messages:<br/>PMMO025</p>                                |
| Movement of the Failing Settlement Instruction  | <p>Shows the Securities Movement Type of the selected Failing Settlement Instruction. (i.e. fulfilled automatically with the Movement Type of the Settlement instruction chosen as T2S Reference of Failing Settlement Instruction).</p> <p>If no Settlement Instruction has been chosen/selected, it must be blank</p> |

**Buttons**

| Buttons |  |
|---------|--|
| Submit  | <p>This function enables you to complete the Re-allocation Request of the penalty. Upon clicking on the submit button you will be asked to enter your PIN for digital signature purposes (NRO). With the entry of the PIN, T2S attaches a digital signature to the modification request entered by the T2S actor.</p> <p>When this button is clicked the pop up is closed and the Penalty – details screen is displayed again as follows:</p> <ul style="list-style-type: none"> <li><input type="checkbox"/> Either displayed updated (i.e. status “REMO”, reason code “RALO” and the Re-allocated to/from penalty fulfilled with the common ID of the new Penalty) if the Re-allocation Re-</li> </ul> |

|               |  |
|---------------|--|
|               | <p>quest is confirmed and executed (the action was triggered in Two-eyes);</p> <ul style="list-style-type: none"> <li><input type="checkbox"/> Or not updated if the Re-allocation Request is Validated and Awaiting for Approval (the action was triggered in Four-eyes and the Penalty - details screen shows the ID for the action awaiting for approval).</li> </ul> <p>When the Re-allocation Request is rejected (i.e. a reason for rejection is provided) the pop up is closed and the Penalty – details screen shows the reason for rejecting the action.</p> <p>Next screen:</p> <ul style="list-style-type: none"> <li><input type="checkbox"/> Penalty - Details Screen [▶ 290]</li> </ul> <p>References for error messages:</p> <ul style="list-style-type: none"> <li><input type="checkbox"/> PMMO008</li> <li><input type="checkbox"/> PMMO021</li> <li><input type="checkbox"/> PMMO023</li> <li><input type="checkbox"/> PMMO025</li> <li><input type="checkbox"/> PMMO033</li> <li><input type="checkbox"/> PMMO034</li> <li><input type="checkbox"/> PMMO035</li> <li><input type="checkbox"/> PMMO037</li> </ul> |
| <p>Cancel</p> | <p>This function enables you to get back to the previous screen without re-allocating the penalty.</p> <p>When Penalty – details screen is displayed again, it should be displayed not updated (with the old values).</p> <p>Next screen:</p> <ul style="list-style-type: none"> <li><input type="checkbox"/> Penalty - Details Screen [▶ 290]</li> </ul>  |



## 2.2.2.28 Penalty - Switch Screen

|                         |   |
|-------------------------|---|
| <b>Context of Usage</b> | <p>This screen is accessible by clicking on the “Switch” button of the Penalty – details screen. This action triggers a pop up screen (the Penalty switch screen) that shows the relevant information to switch the penalty (i.e. the individual Id of the penalty and a free text box to insert a description text). The confirmation will be completed after clicking on the “Submit” button.</p> <p>This function is available if the status of the penalty is “Active”, the penalty is a debit and the penalty is still in the appeal period.</p> <p>The Penalty switch screen is linked to the related Penalty – details screen.</p> <p>This screen is only available for CSD authorised users and T2S Operator user.</p> <p>This screen will not be available during the processing of penalties, i.e. between the Events “PMSS” (Penalty Mechanism- Stop Screens and penalty modification requests) and “PMRR” (Penalty Mechanism- Restart GUI and Restart processing penalty modification requests).</p>  |
| <b>Screen Access</b>    | <ul style="list-style-type: none"><li><input type="checkbox"/> Securities &gt;&gt; Settlement &gt;&gt; Daily Penalties &gt;&gt; <i>Penalty – search/list</i> screen &gt;&gt; Click on the <i>search</i> button &gt;&gt; <i>Penalty – details</i> screen &gt;&gt; Click on the <i>switch</i> button</li><li><input type="checkbox"/> Securities &gt;&gt; Settlement &gt;&gt; Daily Penalties &gt;&gt; <i>Penalty – search/list</i> screen &gt;&gt; Click on the <i>search</i> button &gt;&gt; <i>Penalty – search/list</i> screen &gt;&gt; Click on the <i>details</i> button &gt;&gt; <i>Penalty – details</i> screen &gt;&gt; Click on the <i>switch</i> button</li><li><input type="checkbox"/> Securities &gt;&gt; Settlement &gt;&gt; Settlement Instruction &gt;&gt; <i>Settlement instructions – search/list</i> screen &gt;&gt; Click on the <i>search</i> and/or <i>details</i> button &gt;&gt; <i>Settlement Instruction – details</i> screen &gt;&gt; Click on the <i>associated penalties</i> button &gt;&gt; <i>Penalty – details</i> screen &gt;&gt; Click on the <i>switch</i> button</li></ul> |
| <b>Privileges</b>       | <p>To use this screen, you need the following privilege:</p> <ul style="list-style-type: none"><li><input type="checkbox"/> Penalty Details Query Privilege</li><li><input type="checkbox"/> Settlement Instruction Audit Trail Query</li><li><input type="checkbox"/> Modification of penalties</li></ul>  |
| <b>References</b>       | <p><b>User Instructions Part</b></p> <p>This screen is part of the following business scenarios:</p> <ul style="list-style-type: none"><li><input type="checkbox"/> Modification of existing penalties</li><li><input type="checkbox"/> View the individual penalty details</li></ul>   |

**Screenshot**

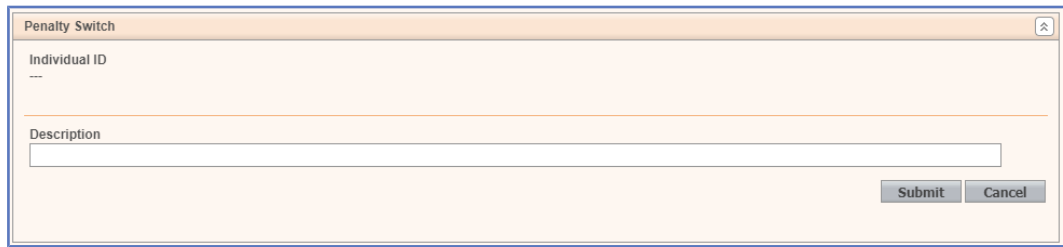

Illustration 67: Penalty - switch screen

**Field**

**Description**

| Penalty Switch |   |
|----------------|---|
| Individual ID  | Shows the individual unique reference assigned to the penalty by T2S.<br><br>This attribute is passed from previous screen. |
| Description    | A free text box to insert a description text.<br><br>This box must be fulfilled.  |

**Buttons**

|        |   |
|--------|---|
| Submit | <p>This function enables you to complete the Switch Request of the penalty. Upon clicking on the submit button you will be asked to enter your PIN for digital signature purposes (NRO). With the entry of the PIN, T2S attaches a digital signature to the modification request entered by the T2S actor.</p> <p>When the button is clicked, the pop up is closed and the Penalty – details screen is displayed again as follows:</p> <ul style="list-style-type: none"> <li>□ Either displayed updated (i.e. status ACTV, reason code SWIC, the description provided by the user, the “Credit/Debit” changed to Credit and the To be recalculated flag set to YES and updated the new Calculation Method when necessary) if the Switch Request is confirmed and executed (the action was triggered in Two-eyes);</li> </ul> |
|--------|---|

|        |  |
|--------|--|
|        | <p><input type="checkbox"/> Or not updated if the Switch Request is Validated and Awaiting for Approval (the action was triggered in Four-eyes and the Penalty - details screen shows the ID for the action awaiting for approval).</p> <p>When the Switch Request is rejected (i.e. a reason for rejection is provided) and the pop up is closed and the Penalty – details screen shows the reason for rejecting the action.</p> <p>Next screen:</p> <p><input type="checkbox"/> Penalty - Details Screen [▶ 290]</p> <p>References for error messages:</p> <p><input type="checkbox"/> PMMO010</p> <p><input type="checkbox"/> PMMO016</p> <p><input type="checkbox"/> PMMO036</p> |
| Cancel | <p>This function enables you to back to the previous screen without switching the penalty.</p> <p>When Penalty – details screen is displayed again, it should be displayed with the old values.</p> <p>Next screen:</p> <p><input type="checkbox"/> Penalty - Details Screen [▶ 290]</p>   |

## 2.3 Cash

### 2.3.1 Cash Account

#### 2.3.1.1 Cash Forecasts - Search/List Screen

**Context of Usage**

This screen contains a number of search fields. By inputting the relevant data, you can search for cash forecasts for T2S dedicated cash account owners, i.e. a party which is a payment bank or central bank. The search results will be dis-

played in a list, which is sorted by the values of the 'Party BIC' column in ascending order (default setting). After selecting an entry, you can proceed further by clicking on the buttons below.

The cash forecast takes into account the cash needs and proceeds of a party on all its T2S dedicated cash accounts related to the pending instructions to be settled during the current or the following business day, as well as the liquidity that can be obtained through auto-collateralisation.

When exporting the content of this screen, you receive the list and the corresponding details for each data record.

During the Start of Day, when the CRDM data is being replicated in the Settlement domain, only the cash forecast data available at the End-of-Day of the previous business day is displayed at the screen. The cash forecast data for the new business day is available as of the end of the CRDM data replication.

During night-time, the cash forecast can only be displayed in-between night-time settlement sequences.

There is no usage restriction for this screen.

**Screen Access**

- Cash >> Cash Account >> Cash Forecast

**Privileges**

To use this screen, you need the following privilege [**▶ 878**]:

- Cash forecast query

**References**

**User Instructions Part**

This screen is part of the following business scenario:

- View overall liquidity [**▶ 677**]

**Business Functionality Document**

This screen corresponds to the following business functions:

- Query cash forecast (T2S.GUI.LMSE.CSH.0050)
- Display cash forecast (T2S.GUI.LMSE.CSH.0060)

**Screenshot**

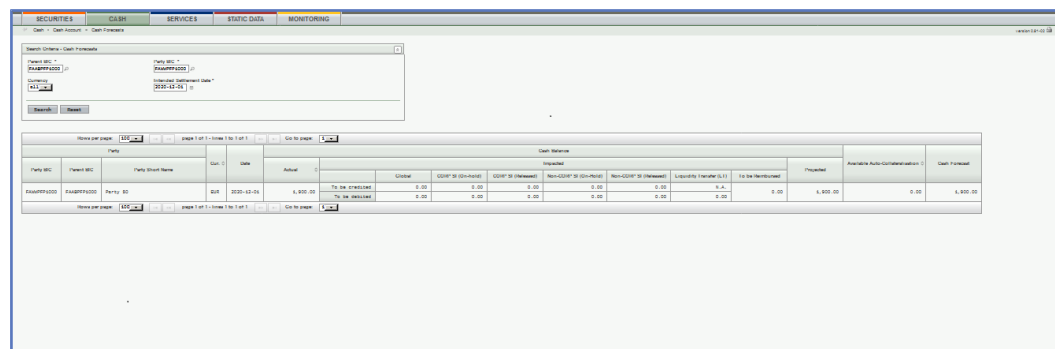

Illustration 68: Cash forecasts – search/list screen

| Field Description         | Cash Forecast – Search Criteria   |  |
|---------------------------|---|--|
| Party BIC*                | Select the BIC of the party owning the T2S dedicated cash account(s) from the drop-down menu or search via the <i>magnifier</i> icon. | References for error messages [ ▶ 964]:<br><input type="checkbox"/> QMPC032<br><input type="checkbox"/> QMPC084  |
| Parent BIC*               | Select the parent BIC of the party owning the T2S dedicated cash account(s) from the drop-down menu.                                  | References for error messages [ ▶ 964]:<br><input type="checkbox"/> QMPC048<br><input type="checkbox"/> QMPC084  |
| Currency                  | Select the currency of the T2S dedicated cash account(s) from the drop-down menu. The default value is 'all'.                         | Reference for error message [ ▶ 964]:<br><input type="checkbox"/> QMPC054  |
| Intended Settlement Date* | Enter the intended settlement date which is used for the calculation of the cash forecast or use the <i>calendar</i> icon.            | Required format is: YYYY-MM-DD<br>The default value is the current business day.<br>This date must be a valid business date equal to or later than the current business date.<br>Reference for error message [ ▶ 964]:<br><input type="checkbox"/> QMPC017 |
| Cash Forecast - List      |   |  |
| <b>Party</b>              |   |  |
| Party BIC                 | Shows the BIC of the party owning the T2S dedicated cash account(s).  | References for error messages [ ▶ 964]:<br><input type="checkbox"/> QMPC032<br><input type="checkbox"/> QMPC084  |
| Parent BIC                | Shows the parent BIC of the party owning the T2S dedicated cash account(s).   | References for error messages [ ▶ 964]:<br><input type="checkbox"/> QMPC048  |

| Cash Forecast – Search Criteria |   |
|---------------------------------|---|
|                                 | <input type="checkbox"/> QMPC084  |
| Party Short Name                | Shows the short name of the party owning the T2S dedicated cash account(s).   |
| Currency                        | Shows the currency of the T2S dedicated cash account(s).<br>Reference for error message [▶ 964]:<br><input type="checkbox"/> QMPC054  |
| Date                            | Shows the intended settlement date which is used for the calculation of the cash forecast.<br>Displayed format is: YYYY-MM-DD   |
| Cash Balances                   |   |
| Actual                          | Shows the sum of the cash balance of the T2S dedicated cash account(s).<br>Provision of '99999...99' in case oversizing occurs in the integer part. Truncation of decimals in case oversizing occurs in the decimal part.   |
| Impacted –To be debited (LT)    | Shows the sum of the debiting liquidity transfer orders which debit a T2S dedicated cash account of the party and which would be effective during the date used for the calculation of the cash forecast.<br>Provision of '99999...99' in case oversizing occurs in the integer part. Truncation of decimals in case oversizing occurs in the decimal part.   |
| Impacted - To be credited (SI)  | Shows the sum of settlement instructions eligible for cash forecast <sup>4</sup> which credit a T2S dedicated cash account of the party and have an intended settlement date earlier than or equal to the intended settlement date used for the calculation of the cash forecast.<br>Provision of '99999...99' in case oversizing occurs in the integer part. Truncation of decimals in case oversizing occurs in the decimal part. |

<sup>4</sup> Eligible for cash forecast refers to settlement instructions that are accepted, matched, not cancelled and not finally settled. This definition includes instructions on hold, under intraday restriction.

| Cash Forecast – Search Criteria                                |  |
|--|--|
| Impacted - To be debited (SI)                                  | <p>Shows the sum of settlement instructions eligible for cash forecast which debit a T2S dedicated cash account of the party and have an intended settlement date earlier than or equal to the intended settlement date used for the calculation of the cash forecast.</p> <p>The pending reverse collateral movements are excluded from this sum.</p> <p>Provision of '99999...99' in case oversizing occurs in the integer part. Truncation of decimals in case oversizing occurs in the decimal part.</p> |
| Impacted - To be credited (SI) – Corporate Actions, On hold    | <p>Shows the sum of the settlement instructions related to corporate actions which are eligible for cash forecast, on hold <sup>5</sup>, credit a T2S dedicated cash account of the party and have an intended settlement date earlier than or equal to the intended settlement date used for the calculation of the cash forecast.</p> <p>Provision of '99999...99' in case oversizing occurs in the integer part. Truncation of decimals in case oversizing occurs in the decimal part.</p>                |
| Impacted –To be credited (SI) – Corporate Actions, Released    | <p>Shows the sum of the settlement instructions related to corporate actions which are eligible for cash forecast, released <sup>6</sup>, credit a T2S dedicated cash account of the party and have an intended settlement date earlier than or equal to the intended settlement date used for the calculation of the cash forecast.</p> <p>Provision of '99999...99' in case oversizing occurs in the integer part. Truncation of decimals in case oversizing occurs in the decimal part.</p>               |
| Impacted –To be credited (SI) – Non Corporate Actions, On hold | <p>Shows the sum of the settlement instructions not related to corporate actions which are eligible for cash forecast, on hold <sup>7</sup>, credit a T2S dedicated cash account of the party and have an intended settlement date earlier than or equal to the intended settlement date used for the calculation of the cash forecast.</p>  |

5 'On Hold' includes CSD Hold, Party Hold, CSD Validation Hold, CoSD Hold, and the non-released part of Partially Released instructions.

6 'Released' includes also the released portion of a Partially Released instruction

7 'On Hold' includes CSD Hold, Party Hold, CSD Validation Hold, CoSD Hold, and the non-released part of Partially Released instructions.

| Cash Forecast – Search Criteria                                  |   |
|--|---|
|  | Provision of '99999...99' in case oversizing occurs in the integer part. Truncation of decimals in case oversizing occurs in the decimal part.  |
| Impacted - To be credited (SI) – Non Corporate Actions, Released | Shows the sum of the settlement instructions not related to corporate actions which are eligible for cash forecast, released <sup>8</sup> , credit a T2S dedicated cash account of the party and have an intended settlement date earlier than or equal to the intended settlement date used for the calculation of the cash forecast.<br><br>Provision of '99999...99' in case oversizing occurs in the integer part. Truncation of decimals in case oversizing occurs in the decimal part.  |
| Impacted –To be debited (SI) – Corporate Actions, On hold        | Shows the sum of the settlement instructions related to corporate actions which are eligible for cash forecast, on hold, debit a T2S dedicated cash account of the party and have an intended settlement date earlier than or equal to the intended settlement date used for the calculation of the cash forecast.<br><br>The pending reverse collateral movements are excluded from this sum.<br><br>Provision of '99999...99' in case oversizing occurs in the integer part. Truncation of decimals in case oversizing occurs in the decimal part.  |
| Impacted - To be debited (SI) – Corporate Actions, Released      | Shows the sum of the settlement instructions related to corporate actions which are eligible for cash forecast, released, debit a T2S dedicated cash account of the party and have an intended settlement date earlier than or equal to the intended settlement date used for the calculation of the cash forecast.<br><br>The pending reverse collateral movements are excluded from this sum.<br><br>Provision of '99999...99' in case oversizing occurs in the integer part. Truncation of decimals in case oversizing occurs in the decimal part. |

8 'Released' includes also the released portion of a Partially Released instruction.



| Cash Forecast – Search Criteria                                 |  |
|---|--|
| Impacted – To be debited (SI) – Non Corporate Actions, On hold  | <p>Shows the sum of the settlement instructions not related to corporate actions which are eligible for cash forecast, on hold, debit a T2S dedicated cash account of the party and have an intended settlement date earlier than or equal to the intended settlement date used for the calculation of the cash forecast.</p> <p>The pending reverse collateral movements are excluded from this sum.</p> <p>Provision of '99999...99' in case oversizing occurs in the integer part. Truncation of decimals in case oversizing occurs in the decimal part.</p>              |
| Impacted – To be debited (SI) – Non Corporate Actions, Released | <p>Shows the sum of the settlement instructions not related to corporate actions which are eligible for cash forecast, released<sup>9</sup>, debit a T2S dedicated cash account of the party and have an intended settlement date earlier than or equal to the intended settlement date used for the calculation of the cash forecast.</p> <p>The pending reverse collateral movements are excluded from this sum.</p> <p>Provision of '99999...99' in case oversizing occurs in the integer part. Truncation of decimals in case oversizing occurs in the decimal part.</p> |
| Impacted - To be reimbursed                                     | <p>Shows the sum of the pending reverse collateral movements which debit a T2S dedicated cash account of the party.</p> <p>Provision of '99999...99' in case oversizing occurs in the integer part. Truncation of decimals in case oversizing occurs in the decimal part.</p>  |
| Projected <sup>10</sup>   | <p>Shows the projected cash balance.</p> <p>The figure consists of the Actual cash balance + To be credited (SI) – To be debited (SI) – To be debited (LT) – To be reimbursed.</p>   |

9 'Released' includes also the released portion of a Partially Released instruction.

10 In UHB and T2S GUI, "projected balance" means the sum of cash balance and pending LTs and SIs and outstanding intraday credit from auto-collateralisation. In T2S UDFS and MyStandards, "projected balance" means the sum of cash balance and pending LTs and SIs (outstanding intraday credit from auto-collateralisation is not part of the calculation, i.e. is not subtracted).

| Cash Forecast – Search Criteria  |   |
|----------------------------------|---|
|                                  | Provision of '99999...99' in case oversizing occurs in the integer part. Truncation of decimals in case oversizing occurs in the decimal part.  |
| Available Auto-Collateralisation | <p>Shows the available auto-collateralisation value of the party.</p> <p>The figure consists of the minimum value between:</p> <ul style="list-style-type: none"> <li><input type="checkbox"/> The available collateral value that the party holds on the securities account(s) linked to its T2S dedicated cash account(s)</li> <li><input type="checkbox"/> The auto-collateralisation limit headroom of the party</li> </ul> <p>Provision of '99999...99' in case oversizing occurs in the integer part. Truncation of decimals in case oversizing occurs in the decimal part.</p> |
| Cash Forecast                    | <p>Shows the sum of the projected cash balance and the available auto-collateralisation.</p> <p>Provision of '99999...99' in case oversizing occurs in the integer part. Truncation of decimals in case oversizing occurs in the decimal part.</p>  |

## Buttons

| Buttons |  |
|---------|--|
| Search  | <p>This function enables you to start a search according to the criteria entered. The results are displayed in a list on the same screen.</p> <p>If the search retrieves a single record, the <i>details</i> screen is displayed directly.</p> <p>Next screens:</p> <ul style="list-style-type: none"> <li><input type="checkbox"/> <i>Cash forecasts – search/list</i> screen</li> <li><input type="checkbox"/> <i>Cash forecast – details</i> screen [ ▶ 331]</li> </ul> <p>References for error messages [ ▶ 964]:</p> <ul style="list-style-type: none"> <li><input type="checkbox"/> QMPC017</li> <li><input type="checkbox"/> QMPC032</li> <li><input type="checkbox"/> QMPC048</li> <li><input type="checkbox"/> QMPC054</li> <li><input type="checkbox"/> QMPC084</li> </ul> |

|         |   |
|---------|---|
| Reset   | This function enables you to set default search criteria and blanks out all optional criteria.<br>Next screen:<br><input type="checkbox"/> <i>Cash forecasts – search/list</i> screen |
| Details | This function enables you to display the details of the selected cash forecast.<br>Next screen:<br><input type="checkbox"/> <i>Cash forecast - details</i> screen [▶ 331]             |

### 2.3.1.2 Cash Forecast - Details Screen

#### Context of Usage

This screen displays detailed information on the cash forecast for a T2S dedicated cash account owner, i.e. a party which is a payment bank or central bank. The global cash forecast is displayed for the previously selected business date and currency. The cash forecast per T2S dedicated cash account of the party for the previously selected business date and currency is displayed in a list on the same screen. You can check the data and proceed further by clicking on the buttons below.

The cash forecast takes into account the cash needs and proceeds of a party on all its T2S dedicated cash accounts related to the pending instructions to be settled during the current or the following business day, as well as the liquidity that can be obtained through auto-collateralisation.

During the Start of Day, when the CRDM data is being replicated in the Settlement domain, only the cash forecast data available at the End-of-Day of the previous business day is displayed at the screen. The cash forecast data for the new business day is available as of the end of the CRDM data replication.

During night-time, the cash forecast can only be displayed in-between night-time settlement sequences.

There is no usage restriction for this screen.

#### Screen Access

Cash >> Cash Account >> Cash Forecast >> *Cash forecasts – search/list* screen >> Click on the *search* and/or *details* button

#### Privileges

No privilege needed to use this screen.

#### References

##### User Instructions Part

This screen is part of the following business scenario:

View overall liquidity [▶ 677]

##### Business Functionality Document

This screen corresponds to the following business functions:

- Display cash forecast (T2S.GUI.LMSE.CSH.0060)

**Screenshot**

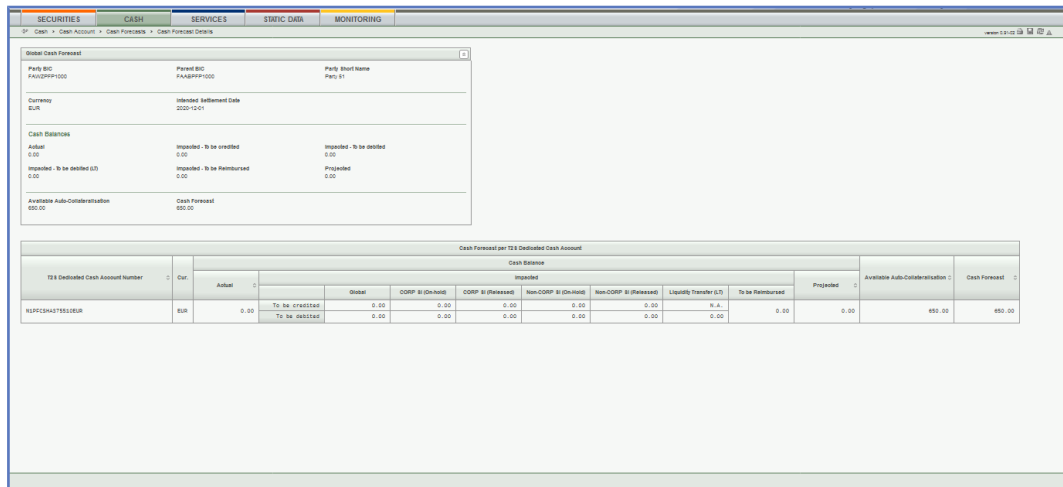

Illustration 69: Cash forecast – details screen

**Field Description**

| Global Cash Forecast         |  |
|------------------------------|--|
| Party BIC                    | Shows the BIC of the party owning the T2S dedicated cash account(s).   |
| Parent BIC                   | Shows the parent BIC of the party owning the T2S dedicated cash account(s).  |
| Currency                     | Shows the currency of the T2S dedicated cash account(s).   |
| Intended Settlement Date     | Shows the intended settlement date used for the calculation of the cash forecast.<br>Displayed format is: YYYY-MM-DD   |
| Cash Balances                |  |
| Actual                       | Shows the sum of the cash balance(s) of the T2S dedicated cash account(s) of the selected party and currency.<br>Provision of '99999...99' in case oversizing occurs in the integer part. Truncation of decimals in case oversizing occurs in the decimal part.  |
| Impacted –To be debited (LT) | Shows the sum of the debiting liquidity transfer orders which debit a T2S dedicated cash account of the selected party and which would be effective during the date used for the calculation of the cash forecast.<br>Provision of '99999...99' in case oversizing occurs in the integer part. Truncation of decimals in case oversizing occurs in the decimal part. |

| Global Cash Forecast             |   |
|----------------------------------|---|
| Impacted –To be debited (SI)     | Shows the sum of settlement instructions eligible for cash forecast which debit a T2S dedicated cash account of the selected party and have an intended settlement date earlier than or equal to the date used for the calculation of the cash forecast <sup>11</sup> .<br><br>Provision of '99999...99' in case oversizing occurs in the integer part. Truncation of decimals in case oversizing occurs in the decimal part. |
| Impacted –To be credited (SI)    | Shows the sum of settled settlement instructions eligible for cash forecast which credit a T2S dedicated cash account of the selected party and have an intended settlement date earlier than or equal to the date used for the calculation of the cash forecast.<br><br>Provision of '99999...99' in case oversizing occurs in the integer part. Truncation of decimals in case oversizing occurs in the decimal part.       |
| Impacted – To be Reimbursed      | Shows the sum of the pending reverse collateral movements which debit a T2S dedicated cash account of the selected party.<br><br>Provision of '99999...99' in case oversizing occurs in the integer part. Truncation of decimals in case oversizing occurs in the decimal part.   |
| Projected <sup>12</sup>          | Shows the projected cash balance.<br><br>The figure consists of the sum<br><br>Actual cash balance + To be credited (SI) – To be debited (SI) – To be debited (LT) – To be reimbursed<br><br>Provision of '99999...99' in case oversizing occurs in the integer part. Truncation of decimals in case oversizing occurs in the decimal part.   |
| Available Auto-Collateralisation | Shows the available auto-collateralisation.<br><br>The figure consists of the minimum value between:  |

11 Eligible for cash forecast refers to settlement instructions that are accepted, matched, not cancelled and not finally settled. This definition includes instructions on hold or under intraday restriction.

12 In UHB and T2S GUI, "projected balance" means the sum of cash balance and pending LTs and SIs and outstanding intraday credit from auto-collateralisation. In T2S UDFS and MyStandards, "projected balance" means the sum of cash balance and pending LTs and SIs (outstanding intraday credit from auto-collateralisation is not part of the calculation, i.e. is not subtracted).

| <b>Global Cash Forecast</b>                         |   |
|---|---|
|   | <ul style="list-style-type: none"> <li><input type="checkbox"/> The available collateral value that the selected party holds on the securities account(s) linked to its T2S dedicated cash account(s) in the selected currency.</li> <li><input type="checkbox"/> The auto-collateralisation limit headroom of the T2S dedicated cash account(s) of the selected party in the selected currency.</li> </ul> <p>Provision of '99999...99' in case oversizing occurs in the integer part. Truncation of decimals in case oversizing occurs in the decimal part.</p> |
| Cash Forecast                                       | <p>Shows the sum of the projected cash balance and the available auto-collateralisation of the selected party and currency.</p> <p>Provision of '99999...99' in case oversizing occurs in the integer part. Truncation of decimals in case oversizing occurs in the decimal part.</p>   |
| <b>Cash Forecast per T2S Dedicated Cash Account</b> |   |
| T2S Dedicated Cash Account Number                   | Shows the number of the T2S dedicated cash account of the selected party with a cash balance and/or pending cash movement(s) in the selected currency.  |
| Currency  | Shows the currency of the T2S dedicated cash account.   |
| <b>Cash Balances</b>                                |   |
| Actual  | Shows the cash balance of the T2S dedicated cash account.   |
| Impacted –To be debited (LT)                        | Shows the sum of the debiting liquidity transfer orders which debit the T2S dedicated cash account and which would be effective during the date used for the calculation of the cash forecast.  |
| Impacted –To be debited (SI)                        | <p>Shows the sum of settlement instructions eligible for cash forecast which debit the T2S dedicated cash account and have an intended settlement date earlier than or equal to the date used for the calculation of the cash forecast.</p> <p>The pending reverse collateral movements are excluded from this sum.</p>   |
| Impacted –To be credited (SI)                       | Shows the sum of settlement instructions eligible for cash forecast which credit the T2S dedicated cash account and have an intended settlement date earlier than or equal to the date used for the calculation of the cash forecast.   |

| Global Cash Forecast  |  |
|---|--|
| Impacted – To be credited (SI) – Corporate Actions, On hold     | Shows the sum of the settlement instructions related to corporate actions which are eligible for cash forecast, on hold <sup>13</sup> , credit a T2S dedicated cash account of the party and have an intended settlement date earlier than or equal to the intended settlement date used for the calculation of the cash forecast.   |
| Impacted –To be credited (SI) – Corporate Actions, Released     | Shows the sum of the settlement instructions related to corporate actions which are eligible for cash forecast, released <sup>14</sup> , credit a T2S dedicated cash account of the party and have an intended settlement date earlier than or equal to the intended settlement date used for the calculation of the cash forecast.  |
| Impacted –To be credited (SI) – Non Corporate Actions, On hold  | Shows the sum of the settlement instructions not related to non corporate actions which are eligible for cash forecast, on hold, credit a T2S dedicated cash account of the party and have an intended settlement date earlier than or equal to the intended settlement date used for the calculation of the cash forecast.  |
| Impacted –To be credited (SI) – Non Corporate Actions, Released | Shows the sum of the settlement instructions not related to corporate actions which are eligible for cash forecast, released, credit a T2S dedicated cash account of the party and have an intended settlement date earlier than or equal to the intended settlement date used for the calculation of the cash forecast.   |
| Impacted –To be debited (SI) – Corporate Actions, On hold       | Shows the sum of the settlement instructions related to corporate actions which eligible for cash forecast, on hold, debit a T2S dedicated cash account of the party and have an intended settlement date earlier than or equal to the intended settlement date used for the calculation of the cash forecast.<br><br>The pending reverse collateral movements are excluded from this sum. |
| Impacted –To be debited (SI) – Corporate Actions, Released      | Shows the sum of the settlement instructions related to corporate actions which are eligible for cash forecast, released, debit a T2S dedicated cash account of the party  |

13 'On Hold' includes CSD Hold, Party Hold, CSD Validation Hold, CoSD Hold, and the non-released part of Partially Released instructions.

14 'Released' includes also the released portion of a Partially Released instruction.

| Global Cash Forecast   |   |
|--|---|
|  | <p>and have an intended settlement date earlier than or equal to the intended settlement date used for the calculation of the cash forecast.</p> <p>The pending reverse collateral movements are excluded from this sum.</p>  |
| Impacted –To be debited (SI) – Non Corporate Actions, On hold  | <p>Shows the sum of the settlement instructions not related to non corporate actions which are eligible for cash forecast, on hold, debit a T2S dedicated cash account of the party and have an intended settlement date earlier than or equal to the intended settlement date used for the calculation of the cash forecast.</p> <p>The pending reverse collateral movements are excluded from this sum.</p> |
| Impacted –To be debited (SI) – Non Corporate Actions, Released | <p>Shows the sum of the settlement instructions not related to corporate actions which are eligible for cash forecast, released, debit a T2S dedicated cash account of the party and have an intended settlement date earlier than or equal to the intended settlement date used for the calculation of the cash forecast.</p> <p>The pending reverse collateral movements are excluded from this sum.</p>    |
| Impacted – To be Reimbursed                                    | Shows the sum of the pending reverse collateral movements which debit the T2S dedicated cash account.   |
| Projected <sup>15</sup>  | <p>Shows the projected cash balance.</p> <p>The figure consists of the sum Actual cash balance + To be credited (SI) - To be debited (SI) - To be debited (LT) - To be reimbursed + impacted collateral movements to be reimbursed</p>  |
| Available Auto-Collateralisation                               | <p>Shows the available auto-collateralisation.</p> <p>The figure consists of the minimum value between:</p> <ul style="list-style-type: none"> <li><input type="checkbox"/> The available collateral value that the selected party holds on the securities account(s) linked to the T2S dedicated cash account.</li> </ul>  |

15 In UHB and T2S GUI, "projected balance" means the sum of cash balance and pending LTs and SIs and outstanding intraday credit from auto-collateralisation. In T2S UDFS and MyStandards, "projected balance" means the sum of cash balance and pending LTs and SIs (outstanding intraday credit from auto-collateralisation is not part of the calculation, i.e. is not subtracted).



| Global Cash Forecast |   |
|----------------------|---|
|                      | <input type="checkbox"/> The auto-collateralisation limit headroom of the T2S dedicated cash account.               |
| Cash Forecast        | Shows the sum of the projected balance and the available auto-collateralisation for the T2S dedicated cash account. |

### 2.3.1.3 Cash Restriction Details - Search/List Screen

#### Context of Usage

This screen contains a number of search fields. By inputting the relevant data, you can search for cash restrictions which are sub-balances blocked or reserved for specific purpose. The search results will be displayed in a list, which is sorted by the values of the 'T2S Dedicated Cash Account Number' column in ascending order (default setting). After selecting an entry, you can proceed further by clicking on the buttons below.

During the Start of Day, when the CRDM data is being replicated in the Settlement domain, only the cash restriction details data available at the End-of-Day of the previous business day is displayed at the screen. The cash restriction details data for the new business day is available as of the end of the CRDM data replication.

During night-time, the cash restriction details can only be displayed in-between night-time settlement sequences.

There is no usage restriction for this screen.

#### Screen Access

- Cash >> Cash Account >> Cash Restriction
- Cash >> Cash Account >> Cash Account Balance >> *T2S dedicated cash account balances – search/list* screen >> Click on the *search* and/or *details* button >> *T2S dedicated cash account balance – details* screen >> Click on the *restriction reference* button
- Monitoring >> Monitoring >> Cash Account Balance >> *T2S dedicated cash account balances – search/list* screen >> Click on the *search* and/or *details* button >> *T2S dedicated cash account balance – details* screen >> Click on the *restriction reference* button
- Cash >> Settlement >> Intra-Balance Movement >> *Intra-balance movements with current and historical status – search* screen >> Click on the *search* button >> *Intra-balance movements – list* screen >> Click on the *details* button >> *Intra-balance movement – details* screen >> Click on the *cash balance details* button >> *T2S dedicated cash account balance – details* screen >> Click on the *restriction reference* button

#### Privileges

To use this screen, you need the following privilege [[▶ 878](#)]:

- T2S dedicated cash account balance detailed restrictions query

**References**

**User Instructions Part**

This screen is part of the following business scenario:

- View cash balances details and related restrictions [▶ 674]

**Business Functionality Document**

This screen corresponds to the following business functions:

- Display T2S dedicated cash account balances (T2S.GUI.LMSE.CSH.0020)

**Screenshot**

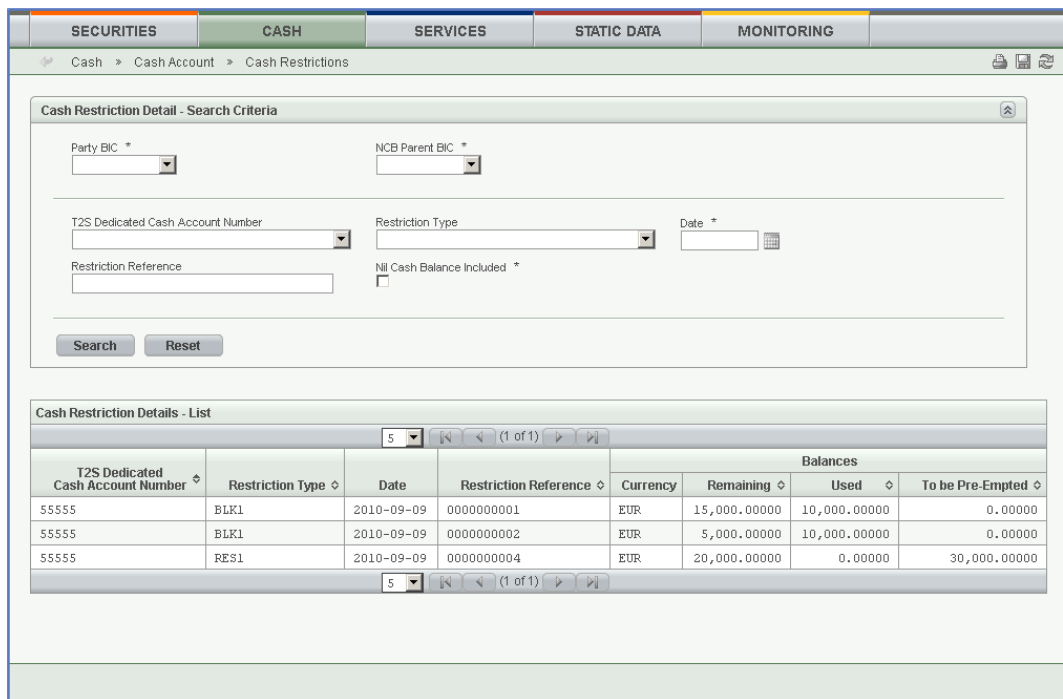

Illustration 70: Cash restriction details – search/list screen

**Field**

**Description**

| Cash Restriction Details – Search Criteria |   |
|--|---|
| Party BIC*                                 | <p>You can choose to either enter the BIC of the party or to select it from the suggested items in the drop-down menu.</p> <p>Required format is: max. 11 characters (SWIFT-x)</p> <p>References for error messages:</p> <ul style="list-style-type: none"> <li><input type="checkbox"/> QMPC032</li> <li><input type="checkbox"/> QMPC084</li> </ul> |
| NCB Parent BIC*                            | <p>You can choose to either enter the parent BIC of the party or to select it from the suggested items in the drop-down menu.</p> <p>Required format is: max. 11 characters (SWIFT-x)</p> <p>References for error messages:</p> <ul style="list-style-type: none"> <li><input type="checkbox"/> QMPC048</li> </ul>                                    |

| Cash Restriction Details – Search Criteria |  |
|--|--|
|  | <input type="checkbox"/> QMPC084   |
| T2S Dedicated Cash Account Number          | Select the number of the T2S dedicated cash account to which the cash restriction applies from the drop-down menu.<br><br>If there is only one possible account for your privileges, this field is already filled in.  |
| Restriction Type                           | You can choose to either enter the type of the cash restriction or to select it from the drop-down menu.<br><br>Required format is: max. 4 characters (SWIFT-x)<br><br>Reference for error message:<br><input type="checkbox"/> QMPC091  |
| Date                                       | Enter the date of the movement(s) related to the restricted cash balance(s) or use the <i>calendar</i> icon. The default value is the current business day.<br><br>Required format is: YYYY-MM-DD<br><br>This date must be a valid business date earlier than or equal to the current business date. |
| Restriction Reference                      | Enter the identification of the cash restriction.<br><br>Required format is: max. 16 characters (SWIFT-x)  |
| Nil Cash Balance Included*                 | Select if cash balances equal to 0 are included. The default value is 'No'(checkbox not checked).  |
| Cash Restriction Details - List            |  |
| T2S Dedicated Cash Account Number          | Shows the number of the T2S dedicated cash account to which the cash restriction applies.  |
| Restriction Type                           | Shows the restriction type of the cash restriction.<br><br>Reference for error message:<br><input type="checkbox"/> QMPC091  |
| Balance Date and Time                      | Shows the date and time of the last movement related to the cash restriction.<br><br>Displayed format is: YYYY-MM-DD hh:mm:ss:µsµsµsµsµs   |
| Restriction Reference                      | Shows the identification of the cash restriction.  |
| Balances                                   |  |
| Currency                                   | Shows the currency of the cash restriction.  |
| Remaining                                  | Shows the amount of the cash restriction remaining.  |

| Cash Restriction Details – Search Criteria |  |
|--|--|
| Used                                       | Shows the amount of the cash restriction that is used.             |
| To be Pre-Empted                           | Shows the amount of the cash restriction that is to be pre-empted. |

**Buttons**

| Buttons |   |
|---------|---|
| Search  | <p>This function enables you to start a search according to the criteria entered. The results are displayed in a list on the same screen.</p> <p>If the search retrieves a single record, the <i>details</i> screen is displayed directly.</p> <p>Next screen:</p> <ul style="list-style-type: none"> <li><input type="checkbox"/> <i>Cash restriction details – search/list</i> screen</li> </ul> <p>References for error messages:</p> <ul style="list-style-type: none"> <li><input type="checkbox"/> QMPC032</li> <li><input type="checkbox"/> QMPC048</li> <li><input type="checkbox"/> QMPC084</li> <li><input type="checkbox"/> QMPC091</li> </ul> |
| Reset   | <p>This function enables you to set default search criteria and blanks out all optional criteria.</p> <p>Next screen:</p> <ul style="list-style-type: none"> <li><input type="checkbox"/> <i>Cash restriction details – search/list</i> screen</li> </ul>   |

### 2.3.1.4 Collateral Values of a Security - Search/List Screen

**Context of Usage**

This screen contains a number of search fields. By inputting the relevant data, you can search for the collateral value of a security for a specific T2S dedicated cash account and security. The search results will be displayed in a list, which is sorted by the values of the 'T2S Dedicated Cash Account Number' column in ascending order (default setting). After selecting an entry, you can proceed further by clicking on the buttons below.

During the Start of Day, when the CRDM data is being replicated in the Settlement domain, only the collateral value of a security data available at the End-of-Day of the previous business day is displayed at the screen. The collateral value of a security data for the new business day is available as of the end of the CRDM data replication.

During night-time, the collateral value of a security can only be displayed in-between night-time settlement sequences.

There is no usage restriction for this screen.

**Screen Access**

- Cash >> Cash Account >> Collateral Values (Security)
- Cash >> Cash Account >> Collateral Values (T2S DCA and Sec.) >> *Collateral value per T2S dedicated cash account and security – search/list* screen >> Click on the *collateral value of securities* button

**Privileges**

To use this screen, you need the following privilege [▶ 879]:

- Collateral value of a security query

**References**

**User Instructions Part**

This screen is not part of a business scenario.

**Business Functionality Document**

This screen corresponds to the following business functions:

- Query current collateral value of security (per securities account) (T2S.GUI.LMSE.CSH.0130)
- Display current collateral value of security (per securities account) (T2S.GUI.LMSE.CSH.0140)

**Screenshot**

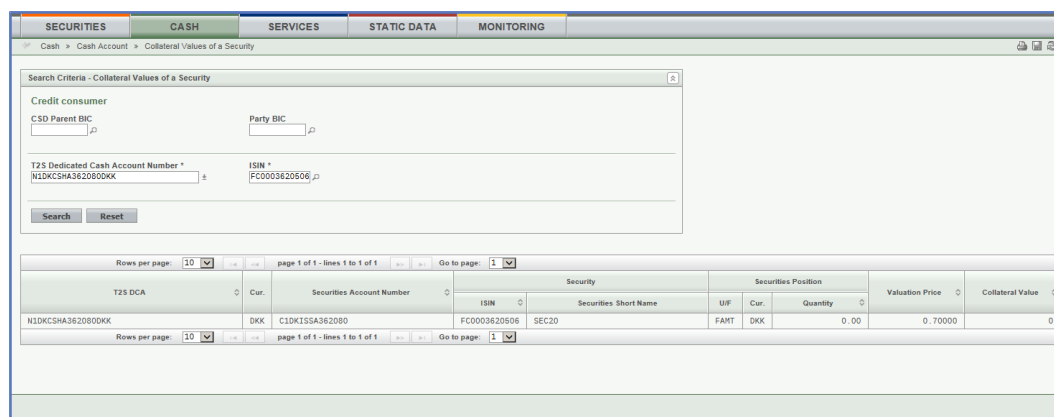

Illustration 71: Collateral value of a security – search/list screen

**Field Description**

| Collateral Value of a Security – Search Criteria |  |
|--|--|
| Credit Consumer                                  |  |
| Party BIC  | <p>You can choose to either enter the BIC of the securities account owner or to select it from the suggested items in the drop-down menu.</p> <p>References for error messages [▶ 965]:</p> <ul style="list-style-type: none"> <li><input type="checkbox"/> QMPC032</li> <li><input type="checkbox"/> QMPC084</li> </ul> |

| Collateral Value of a Security – Search Criteria |  |
|--|--|
|  | If the 'Party BIC' field is filled in, the 'CSD Parent BIC' field must also be filled in.  |
| CSD Parent BIC                                   | <p>You can choose to either enter the parent BIC of the CSD or to select it from the suggested items in the drop-down menu.</p> <p>References for error messages [ ▶ 965]:</p> <ul style="list-style-type: none"> <li><input type="checkbox"/> QMPC032</li> <li><input type="checkbox"/> QMPC084</li> </ul> <p>If the 'CSD Parent BIC' field is filled in, the 'Party BIC' field must also be filled in.</p> |
| T2S Dedicated Cash Account Number*               | <p>You can choose to either enter the number of the T2S dedicated cash account or to select it from the suggested items in the drop-down menu.</p> <p>Reference for error message [ ▶ 965]:</p> <ul style="list-style-type: none"> <li><input type="checkbox"/> QMPC031</li> </ul> <p>If only one account is possible, this field is already filled in.</p>  |
| ISIN*  | <p>Select the ISIN of the security from the drop-down menu.</p> <p>Required format is: max. 12 characters (SWIFT-x)</p> <p>Reference for error message [ ▶ 965]:</p> <ul style="list-style-type: none"> <li><input type="checkbox"/> QMPC018</li> </ul>  |
| Collateral Value of a Security – List            |  |
| T2S Dedicated Cash Account Number                | <p>Shows the number of the T2S dedicated cash account related to the collateral value of the security list item.</p> <p>Reference for error message [ ▶ 965]:</p> <ul style="list-style-type: none"> <li><input type="checkbox"/> QMPC031</li> </ul>   |
| Currency   | Shows the currency of the T2S dedicated cash account.  |
| Securities Account Number                        | Shows the number of the securities account related to the collateral value of the security list item.  |
| Security   |  |
| ISIN   | <p>Shows the ISIN of the security.</p> <p>Reference for error message [ ▶ 965]:</p> <ul style="list-style-type: none"> <li><input type="checkbox"/> QMPC018</li> </ul>   |

| Collateral Value of a Security – Search Criteria |   |
|--|---|
| Securities Short Name                            | Shows the short name of the security.   |
| Securities Position                              |   |
| Settlement Type                                  | Shows the quantity type related to the securities from the possible values:<br><input type="checkbox"/> UNIT<br><input type="checkbox"/> FAMT (for face amount)   |
| Currency   | Shows the currency related to the securities if expressed in face amount.   |
| Quantity   | Shows the total quantity of securities for the aggregated securities positions.<br><br>Provision of '99999...99' in case oversizing occurs in the integer portion. Truncation of decimals in case oversizing occurs in the decimal portion.               |
| Valuation Price                                  | Shows the valuation price of the securities for the credit provider (CB or settlement bank).  |
| Collateral Value                                 | Shows the resulting collateral value of the security for the aggregated securities positions.<br><br>Provision of '99999...99' in case oversizing occurs in the integer portion. Truncation of decimals in case oversizing occurs in the decimal portion. |

## Buttons

|        |   |
|--------|---|
| Search | <p>This function enables you to start a search according to the criteria entered. The results are displayed in a list on the same screen.</p> <p>Next screen:</p> <ul style="list-style-type: none"> <li><input type="checkbox"/> <i>Collateral value of a security – search/list screen</i></li> </ul> <p>References for error messages [ ▶ 965]:</p> <ul style="list-style-type: none"> <li><input type="checkbox"/> QMPC018</li> <li><input type="checkbox"/> QMPC031</li> <li><input type="checkbox"/> QMPC032</li> <li><input type="checkbox"/> QMPC084</li> </ul> |
| Reset  | This function enables you to set default search criteria and blanks out all optional criteria.  |

|              |   |
|--------------|---|
| Next screen: |   |
|              | <input type="checkbox"/> <i>Collateral value of a security – search/list screen</i> |

### 2.3.1.5 Collateral Values per T2S Dedicated Cash Account and Security - Search/List Screen

#### Context of Usage

This screen contains a number of search fields. By inputting the relevant data, you can search for the collateral value for a party and any or all of its T2S dedicated cash accounts. The search results will be displayed in a list, which is sorted by the values of the (1) 'T2S Dedicated Cash Account Number' (2) Owner of the Securities Account Parent BIC (3) Owner of the Securities Account Party BIC (4) Security-ISIN columns in ascending order (default setting).

During the Start of Day, when the CRDM data is being replicated in the Settlement domain, only the collateral value per T2S dedicated cash account data available at the End-of-Day of the previous business day is displayed at the screen. The collateral value per T2S dedicated cash account data for the new business day is available as of the end of the CRDM data replication.

During night-time, the collateral value per T2S dedicated cash account and security can only be displayed in-between night-time settlement sequences.

There is no usage restriction for this screen.

#### Screen Access

- Cash >> Cash Account >> Collateral Values (T2S DCA and Sec.)
- Cash >> Cash Account >> Total Collateral Values (T2S DCA) >> *Total collateral value per T2S dedicated cash account – search/list screen* >> Click on *detail of collateral value* button

#### Privileges

To use this screen, you need the following privilege [► 879]:

- Collateral value per T2S dedicated cash account query

#### References

##### User Instructions Part

This screen is not part of a business scenario.

##### Business Functionality Document

This screen corresponds to the following business functions:

- Query total current collateral value (per T2S dedicated cash account and security) (T2S.GUI.LMSE.CSH.0110)
- Display total current collateral value (per T2S dedicated cash account and security) (T2S.GUI.LMSE.CSH.0120)



Screenshot

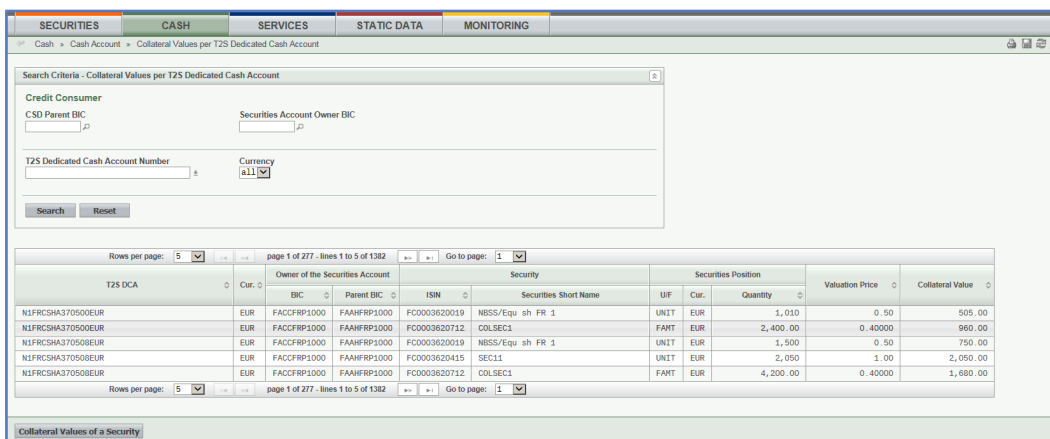

Illustration 72: Collateral value per T2S dedicated cash account and security – search/list screen

Field Description

| Collateral Value per T2S Dedicated Cash Account and Security – Search Criteria |  |
|--|--|
| <b>Credit Consumer</b>   |  |
| Securities Account Owner BIC   | Select the BIC of the securities account owner (credit consumer) from the drop-down menu or search via the <i>magnifier</i> icon. If the BIC is not contained in the drop-down menu please enter the BIC manually.<br><br>References for error messages [ 966]:<br><br><input type="checkbox"/> QMPC032<br><input type="checkbox"/> QMPC084<br><br>If none of the fields are filled in, then the privileges and access rights of the requesting party are applied. |
| CSD Parent BIC   | Select the parent BIC of the CSD (of the credit consumer) from the drop-down menu or search via the <i>magnifier</i> icon. If the BIC is not contained in the drop-down menu please enter the BIC manually.<br><br>References for error messages [ 966]:<br><br><input type="checkbox"/> QMPC032<br><input type="checkbox"/> QMPC084<br><br>If none of the fields are filled in, then the privileges and access rights of the requesting party are applied.        |
| T2S Dedicated Cash Account Number  | Select the number of the T2S dedicated cash account from the drop-down menu.<br><br>Reference for error message [ 966]:<br><br><input type="checkbox"/> QMPC031<br><br>If only one account is possible, this field is already filled in.   |

| <b>Collateral Value per T2S Dedicated Cash Account and Security – Search Criteria</b> |   |
|---|---|
|   | If none of the fields are filled in, then the privileges and access rights of the requesting party are applied.   |
| Currency  | Select the currency of the T2S dedicated cash account from the drop-down menu. The default value is 'all'.  |
| <b>Collateral Value per T2S Dedicated Cash Account and Security – List</b>            |   |
| T2S Dedicated Cash Account Number   | Shows the number of the T2S dedicated cash account relating to the collateral value of the security list item.<br>Reference for error message [▶ 966]:<br><input type="checkbox"/> QMPC031  |
| Currency  | Shows the currency of the T2S dedicated cash account.   |
| <b>Securities Account Owner</b>   |   |
| Party BIC   | Shows the BIC of the securities account owner of the securities account that holds the valuated securities  |
| Parent BIC  | Shows the parent BIC of the securities account owner  |
| <b>Security</b>   |   |
| ISIN  | Shows the ISIN of the security.   |
| Securities Short Name   | Shows the short name of the security.   |
| <b>Securities Positions</b>   |   |
| Settlement Type   | Shows the quantity type related to the securities from the possible values:<br><input type="checkbox"/> Unit<br><input type="checkbox"/> FAMT (for face amount)   |
| Currency  | Shows the currency related to the securities if expressed in face amount.   |
| Quantity  | Shows the total quantity of securities for the aggregated securities positions.<br>Provision of '99999...99' in case oversizing occurs in the integer portion. Truncation of decimals in case oversizing occurs in the decimal portion. |
| Valuation Price   | Shows the valuation price of the securities for the credit provider (CB or settlement bank).  |

| Collateral Value per T2S Dedicated Cash Account and Security – Search Criteria |   |
|--|---|
| Collateral Value   | Shows the resulting collateral value of the security for the aggregated securities positions.<br><br>Provision of '99999...99' in case oversizing occurs in the integer portion. Truncation of decimals in case oversizing occurs in the decimal portion. |

**Buttons**

| Buttons                        |  |
|--------------------------------|--|
| Search                         | This function enables you to start a search according to the criteria entered. The results are displayed in a list on the same screen.<br><br>Next screen:<br><br><input type="checkbox"/> <i>Collateral value per T2S dedicated cash account and security – search/list screen</i><br><br>References for error messages [ ▶ 966]:<br><br><input type="checkbox"/> QMPC031<br><input type="checkbox"/> QMPC032<br><input type="checkbox"/> QMPC084 |
| Reset                          | This function enables you to set default search criteria and blanks out all optional criteria.<br><br>Next screen:<br><br><input type="checkbox"/> <i>Collateral value per T2S dedicated cash account and security – search/list screen</i>  |
| Collateral Value of Securities | This function enables you to search for the collateral value of a security.<br><br>Next screen:<br><br><input type="checkbox"/> <i>Collateral value of a security – search/list screen</i> [ ▶ 340]<br><br>The values of the selected entry are passed to the next screen as search criteria.  |

### 2.3.1.6 Limits - Search/list Screen

See *Limits – search/list Screen*

### 2.3.1.7 Limit - New/Edit Screen

See *Limit – New/Edit Screen*.

## 2.3.1.8 Limit Utilisation - Search/List Screen

### Context of Usage

This screen contains a number of search fields. By inputting the relevant data, you can search for the current limit utilisation for a given credit consumer. Depending on the input criteria, a credit consumer or credit provider can retrieve the following information:

- CBs, as credit provider, can see the utilisation of an auto-collateralisation limit associated to the T2S dedicated cash accounts of its payment banks;
- Payment banks, as credit consumer, can see the utilisation of their auto-collateralisation limit associated to their T2S dedicated cash accounts;
- Payment banks, as credit provider, can see the utilisation of the limits of their clients (three types of limits – external guarantee, auto-collateralisation, unsecured credit) associated to the Payment banks T2S dedicated cash accounts;
- Payment bank clients, as credit consumer, can see the utilisation of their limits (three types of limits – external guarantee, auto-collateralisation, unsecured credit) associated to the T2S dedicated cash accounts of their payment banks.

The search results will be displayed in a list, which is sorted by the value of the columns 'Credit Provider Party BIC', in ascending order (default setting). After selecting an entry, you can proceed further by clicking the buttons below.

During the Start of Day, when the CRDM data is being replicated in the Settlement domain, only the limit utilisation data available at the End-of-Day of the previous business day is displayed at the screen. The limit utilisation data for the new business day is available as of the end of the CRDM data replication.

During night-time, the limit utilisation can only be displayed in-between night-time settlement sequences.

There is no usage restriction for this screen.

### Screen Access

- Cash >> Cash Account >> Limit Utilisation
- Securities >> Securities Account >> Limit Utilisation
- Static Data >> T2S Dedicated Cash Account >> Limits >> *Limits – search/list* screen >> Click on the *limit utilisation* button
- Cash >> Cash Account >> Limits >> *Limits – search/list* screen >> Click on the *limit utilisation* button
- Static Data >> T2S Dedicated Cash Account >> T2S Dedicated Cash Account >> *T2S dedicated cash accounts – search/list* screen >> Click on the *search* and/or *details* button >> *T2S dedicated cash account – details* screen >> Click on the *limits* button >> *Limits – search/list* screen >> Click on the *limit utilisation* button

- Static Data >> Parties >> Parties >> **Parties – search/list screen** >> Click on the *search* and/or *details* button >> **Party – details screen** >> Click on the *T2S dedicated cash account* button >> **T2S dedicated cash accounts – search/list screen** >> Click on the *search* and/or *details* button >> **T2S dedicated cash account – details screen** >> Click on the *limits* button >> **Limits – search/list screen** >> Click on the *limit utilisation* button

**Privileges**

To use this screen, you need the following privilege [▶ 888]:

- Limit utilisation query

**References**

**User Instructions Part**

This screen is part of the following business scenario:

- View overall liquidity [▶ 677]

**Business Functionality Document**

This screen corresponds to the following business functions:

- Display limit utilisation (T2S.GUI.SDSE.LMT.0080)
- Query limit utilisation (T2S.GUI.SDSE.LMT.0070)

**Screenshot**

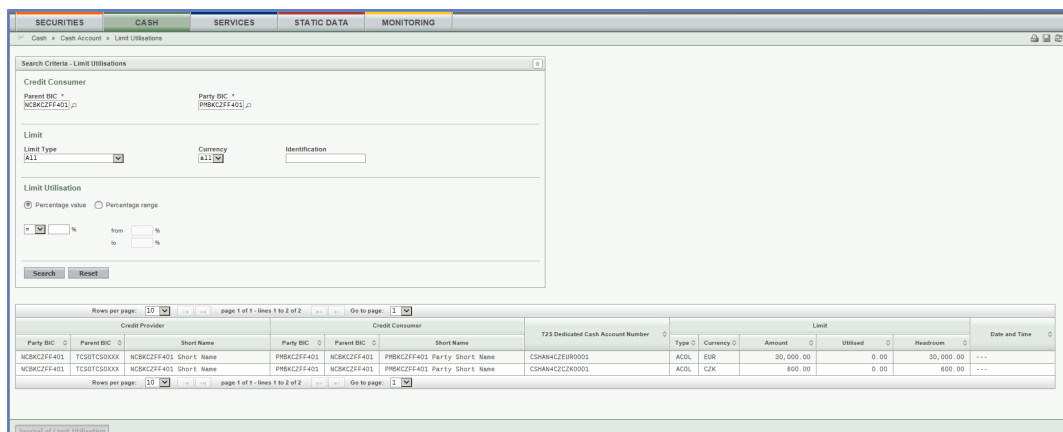

Illustration 73: Limit utilisation – search/list screen

**Field**

**Description**

| Limit Utilisation – Search Criteria |  |
|-------------------------------------|--|
| Credit Consumer                     |  |
| Party BIC                           | You can choose to either enter the BIC of the party or to select it from the suggested items in the drop-down menu.<br><br>If the querying party is a CB or a payment/settlement bank, the Party BIC is optional, otherwise it is mandatory.<br><br>Required format is: max. 11 characters (SWIFT-x) |
| Parent BIC                          | You can choose to either enter the parent BIC of the party or to select it from the suggested items in the drop-down menu.   |

| Limit Utilisation – Search Criteria |  |
|-------------------------------------|--|
|                                     | <p>If the querying party is a CB or a payment/settlement bank, the Party BIC is optional, otherwise it is mandatory.</p> <p>Required format is: max. 11 characters (SWIFT-x)</p>   |
| Limit                               |  |
| Limit Type                          | <p>Select the limit type from one of the possible values:</p> <ul style="list-style-type: none"> <li><input type="checkbox"/> All (default value)</li> <li><input type="checkbox"/> EXGT (External Guarantee)</li> <li><input type="checkbox"/> ACOL (Auto-collateralisation)</li> <li><input type="checkbox"/> UCDD (Unsecured Credit)</li> </ul> <p>If the querying party is a CB, the only possible value is 'ACOL'.</p>  |
| Currency                            | <p>Select the currency of the T2S dedicated cash account from the drop-down menu. The default value is 'all'.</p>  |
| Identification                      | <p>Enter the technical identifier of the limit.</p> <p>Required format: Integer</p> <p>Reference for error message: [▶ 1040]</p> <ul style="list-style-type: none"> <li><input type="checkbox"/> QMPC036</li> </ul>  |
| Limit Utilisation                   |  |
| Percentage value                    | <p>Select whether the limit utilisation criteria is by percentage value.</p> <p>Select the limit utilisation operator from one of the possible values:</p> <ul style="list-style-type: none"> <li><input type="checkbox"/> = (default value)</li> <li><input type="checkbox"/> &gt;=</li> <li><input type="checkbox"/> &gt;</li> <li><input type="checkbox"/> &lt;=</li> <li><input type="checkbox"/> &lt;</li> </ul> <p>Enter the limit utilisation as a percentage.</p> <p>Required format is: max. 5 digit(s) incl. decimal point (thereof max. 2 decimal places and decimal point)</p> |
| Percentage range                    | <p>Select whether the limit utilisation criteria is by percentage range.</p> <p>Enter the 'From' range delimiter of the limit utilisation as a percentage.</p>   |

| Limit Utilisation – Search Criteria |   |
|-------------------------------------|---|
|                                     | <p>Required format is: max. 5 digit(s) incl. decimal point (thereof max. 2 decimal places and decimal point).</p> <p>Enter the 'To' range delimiter of the limit utilisation as a percentage.</p> <p>Required format is: max. 5 digit(s) incl. decimal point (thereof max. 2 decimal places and decimal point).</p> <p>Both fields must be filled in if the range of value is selected.</p> <p>Reference for error message: [ ▶ 1040]</p> <p><input type="checkbox"/> QMPC040</p> |
| Limit Utilisation – List            |   |
| Credit Provider                     |   |
| Party BIC                           | Shows the BIC of the credit provider.   |
| Parent BIC                          | Shows the parent BIC of the credit provider.  |
| Short Name                          | Shows the party short name of the credit provider.  |
| Credit Consumer                     |   |
| Party BIC                           | Shows the BIC of the credit consumer.   |
| Parent BIC                          | Shows the parent BIC of the credit consumer.  |
| Short Name                          | Shows the party short name of the credit consumer.  |
| T2S Dedicated Cash Account Number   | Shows the number of the T2S dedicated cash account relating to the limit utilisation.   |
| Limit Type                          |   |
| Limit Type                          | <p>Shows the type of the limit from one of the possible values:</p> <p><input type="checkbox"/> EXGT (External Guarantee)</p> <p><input type="checkbox"/> ACOL (Auto-collateralisation)</p> <p><input type="checkbox"/> UCDD (Unsecured Credit)</p>   |
| Currency                            | Shows the currency of the T2S dedicated cash account.   |
| Amount                              | Shows the amount of the limit.  |
| Used amount                         | Shows the amount of the limit that has been utilised.   |
| Headroom                            | Shows the headroom of the limit.  |
| Date and Time                       | <p>Shows the date and time of the most recent usage of the limit.</p> <p>Displayed format is: YYYY-MM-DD hh:mm:ss:µsµsµsµsµsµs</p>  |

**Buttons**

|                                |  |
|--------------------------------|--|
| Search                         | <p>This function enables you to start a search according to the criteria entered. The results are displayed in a list on the same screen.</p> <p>Next screen:</p> <ul style="list-style-type: none"> <li><input type="checkbox"/> <i>Limit utilisation – search/list</i> screen</li> </ul> <p>References for error messages: [▶ 1040]</p> <ul style="list-style-type: none"> <li><input type="checkbox"/> QMPC036</li> <li><input type="checkbox"/> QMPC040</li> </ul> |
| Reset                          | <p>This function enables you to set default search criteria and blanks out all optional criteria.</p> <p>Next screen:</p> <ul style="list-style-type: none"> <li><input type="checkbox"/> <i>Limit utilisation – search/list</i> screen</li> </ul>   |
| Journal of a Limit Utilisation | <p>This function enables you to display the details of the journal of limit utilisation for the selected limit. The values of the selected row are passed as selection criteria to the next screen.</p> <p>Next screen:</p> <ul style="list-style-type: none"> <li><input type="checkbox"/> <i>Limit utilisation journal – search/list</i> screen [▶ 352]</li> </ul>   |

### 2.3.1.9 Limit Utilisation Journal - Search/List Screen

**Context of Usage**

This screen contains a number of search fields. By inputting the relevant data, you can search for the current limit utilisation journal for a given credit consumer. Depending on the input criteria, a credit consumer or credit provider can retrieve following information:

- CBs, as credit provider, can see the utilisation journal of an auto-collateralisation limit associated to the T2S dedicated cash accounts of its payment banks;
- Payment banks, as credit consumer, can see the utilisation journal of their auto-collateralisation limit associated to their T2S dedicated cash accounts;
- Payment banks, as credit provider, can see the utilisation journal of the limits of their clients (three types of limits – external guarantee, auto-collateralisation, unsecured credit) associated to the Payment banks T2S dedicated cash accounts;



- Payment bank clients, as credit consumer, can see the utilisation journal of their limits (three types of limits – external guarantee, auto-collateralisation, unsecured credit) associated to the T2S dedicated cash accounts of their payment banks.

The search results will be sorted before being displayed in a list by the values of the following columns in descending order:

1. T2S Dedicated Cash Account Number
2. Credit consumer
3. Limit Type

The results cannot be sorted afterwards.

After selecting an entry, you can proceed further by clicking the buttons below.

During the Start of Day, when the CRDM data is being replicated in the Settlement domain, only the limit utilisation Journal data available at the End-of-Day of the previous business day is displayed at the screen. The limit utilisation Journal data for the new business day is available as of the end of the CRDM data replication.

During night-time, the limit utilisation journal can only be displayed in-between night-time settlement sequences.

There is no usage restriction for this screen.

## Screen Access

- Cash >> Cash Account >> Limit Utilisation Journal
- Securities >> Securities Account >> Limit Utilisation Journal
- Static Data >> T2S Dedicated Cash Account >> Limits >> *Limits – search/list* screen >> Click on the *limit utilisation* button >> *Limit utilisation – search/list* screen >> Click on the *journal of limit utilisation* button
- Cash >> Cash Account >> Limits >> *Limits – search/list* screen >> Click on the *limit utilisation* button >> *Limit utilisation – search/list* screen >> Click on the *journal of limit utilisation* button
- Static Data >> T2S Dedicated Cash Account >> T2S Dedicated Cash Account >> *T2S dedicated cash accounts – search/list* screen >> Click on the *search* and/or *details* button >> *T2S dedicated cash account – details* screen >> Click on the *limits* button >> *Limits – search/list* screen >> Click on the *limit utilisation* button >> *Limit utilisation – search/list* screen >> Click on the *journal of limit utilisation* button
- Static Data >> Parties >> Parties >> *Parties – search/list* screen >> Click on the *search* and/or *details* button >> *Party – details* screen >> Click on the *T2S dedicated cash account* button >> *T2S dedicated cash accounts –*

search/list screen >> Click on the *search* and/or *details* button >> *T2S dedicated cash account – details* screen >> Click on the *limits* button >> *Limits – search/list* screen >> Click on the *limit utilisation* button >> *Limit utilisation – search/list* screen >> Click on the *journal of limit utilisation* button

- Cash >> Liquidity >> Outstanding Auto-Coll. Credit >> *Outstanding auto-collateralisation credits – search/list* screen >> Click on the *journal of limit utilisation* button

**Privileges**

To use this screen, you need the following privilege [**888**]:

- Limit utilisation journal query

**References**

**User Instructions Part**

This screen is part of the following business scenario:

- View overall liquidity [**677**]

**Business Functionality Document**

This screen corresponds to the following business functions:

- Query limit utilisation journal (T2S.GUI.SDSE.LMT.0090)
- Display limit utilisation journal (T2S.GUI.SDSE.LMT.0100)

**Screenshot**

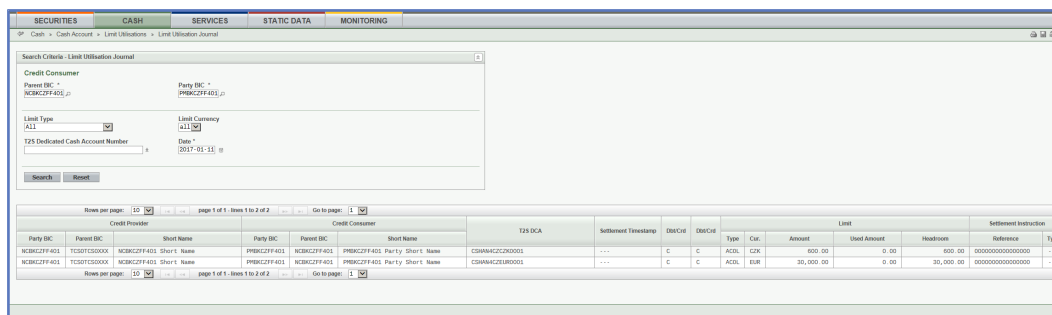

Illustration 74: Limit utilisation journal – search/list screen

**Field Description**

| Limit Utilisation Journal – Search Criteria |   |
|---|---|
| Credit Consumer                             |   |
| Party BIC*                                  | Select the BIC of the party from the drop-down menu or search via the <i>magnifier</i> icon.<br><br>Required format is: max. 11 characters (SWIFT-x)  |
| Parent BIC*                                 | Select the parent BIC of the party from the drop-down menu or search via the <i>magnifier</i> icon.<br><br>Required format is: max. 11 characters (SWIFT-x)   |
| Limit Type                                  | Select the limit type from one of the possible values: <ul style="list-style-type: none"> <li><input type="checkbox"/> All (default value)</li> <li><input type="checkbox"/> EXGT (External Guarantee)</li> <li><input type="checkbox"/> ACOL (Auto-collateralisation)</li> </ul> |

| Limit Utilisation Journal – Search Criteria |   |
|---|---|
|   | <input type="checkbox"/> UCDT (Unsecured Credit)  |
| Limit Currency                              | Select the currency of the T2S dedicated cash account from the drop-down menu. The default value is 'all'.  |
| T2S Dedicated Cash Account Number           | Select the number of the T2S dedicated cash account from the drop-down menu.<br>Required format is: max. 34 characters (SWIFT-x)<br>If there is only one possible account, this field is already filled in.<br>Reference for error message: [▶ 1041]<br><input type="checkbox"/> QMPC031  |
| Date*                                       | Enter the date of the limit utilisation or use the <i>calendar</i> icon.<br>Required format is: YYYY-MM-DD.<br>The default value is the current business date. It has to be a valid business date less than or equal to the current business date.<br>Reference for error message: [▶ 1041]<br><input type="checkbox"/> QMPC055 |
| Limit Utilisation Journal – List            |   |
| Credit Provider                             |   |
| Party BIC                                   | Shows the BIC of the credit provider.   |
| Parent BIC                                  | Shows the parent BIC of the credit provider.  |
| Short Name                                  | Shows the party short name of the credit provider.  |
| Credit Consumer                             |   |
| Party BIC                                   | Shows the BIC of the credit consumer.   |
| Parent BIC                                  | Shows the parent BIC of the credit consumer.  |
| Short Name                                  | Shows the party short name of the credit consumer.  |
| T2S Dedicated Cash Account Number           | Shows the number of the T2S dedicated cash account relating to the journal of limit utilisation.<br>Reference for error message: [▶ 1041]<br><input type="checkbox"/> QMPC031   |
| Settlement Timestamp                        | Shows the timestamp of the limit utilisation.<br>Displayed format is: YYYY-MM-DD hh:mm:ss:µsµsµsµsµs  |

| Limit Utilisation Journal – Search Criteria |  |
|---|--|
| Debit/Credit Indicator                      | Show the debit credit indicator of the limit from the possible values:<br><input type="checkbox"/> D (Debit)<br><input type="checkbox"/> C (Credit)  |
| Limit                                       |  |
| Limit Type                                  | Shows the type of the limit from one of the possible values:<br><input type="checkbox"/> EXGT (External Guarantee)<br><input type="checkbox"/> ACOL (Auto-collateralisation)<br><input type="checkbox"/> UCDT (Unsecured Credit) |
| Currency                                    | Shows the currency of the T2S dedicated cash account.  |
| Amount                                      | Shows the amount of the limit.   |
| Used amount                                 | Shows the amount of the limit after this utilisation.  |
| Headroom                                    | Shows the headroom of the limit.   |
| Settlement Instruction                      |  |
| Reference                                   | Shows the reference of the settlement instruction related to the utilisation journal entry.  |
| Instruction Type                            | Shows the type of the settlement instruction related to the utilisation journal entry.   |

**Buttons**

|        |   |
|--------|---|
| Search | This function enables you to start a search according to the criteria entered. The results are displayed in a list on the same screen.<br><br>Next screen:<br><input type="checkbox"/> <i>Limit utilisation journal – search/list</i> screen<br><br>References for error messages: [▶ 1041]<br><input type="checkbox"/> QMPC031<br><input type="checkbox"/> QMPC055 |
| Reset  | This function enables you to set default search criteria and blanks out all optional criteria.<br><br>Next screen:<br><input type="checkbox"/> <i>Limit utilisation journal – search/list</i> screen  |

## 2.3.1.10 T2S DCA Balances - Search/List Screen

### Context of Usage

This screen contains a number of search fields. By inputting the relevant data, you can search for T2S dedicated cash account balances. The search results will be displayed in a list, which is sorted by the value of the 'T2S Dedicated Cash Account Number' column in ascending order (default setting). After selecting one entry, you can further proceed by clicking on the buttons below.

When exporting the content of this screen, you receive the list and the corresponding details for each data record.

During the Start of Day, when the CRDM data is being replicated in the Settlement domain, only the cash balances data available at the End-of-Day of the previous business day is displayed at the screen. The cash balances data for the new business day is available as of the end of the CRDM data replication.

During night-time, the cash balances can only be displayed in-between night-time settlement sequences.

This screen is not relevant for CSD or CSD participant users.

### Screen Access

- Cash >> Cash Account >> Cash Account Balances
- Monitoring >> Monitoring >> Cash Account Balances

### Privileges

To use this screen, you need the following privilege [▶ 903]:

- T2S dedicated cash account balance query

### References

#### User Instructions Part

This screen is part of the following business scenarios:

- View cash balances details and related postings [▶ 673]
- View cash balances details and related restrictions [▶ 674]

#### Business Functionality Document

This screen corresponds to the following business functions:

- Query T2S dedicated cash account balances (T2S.GUI.LMSE.CSH.0010)
- Display T2S dedicated cash account balances (T2S.GUI.LMSE.CSH.0020)

Screenshot

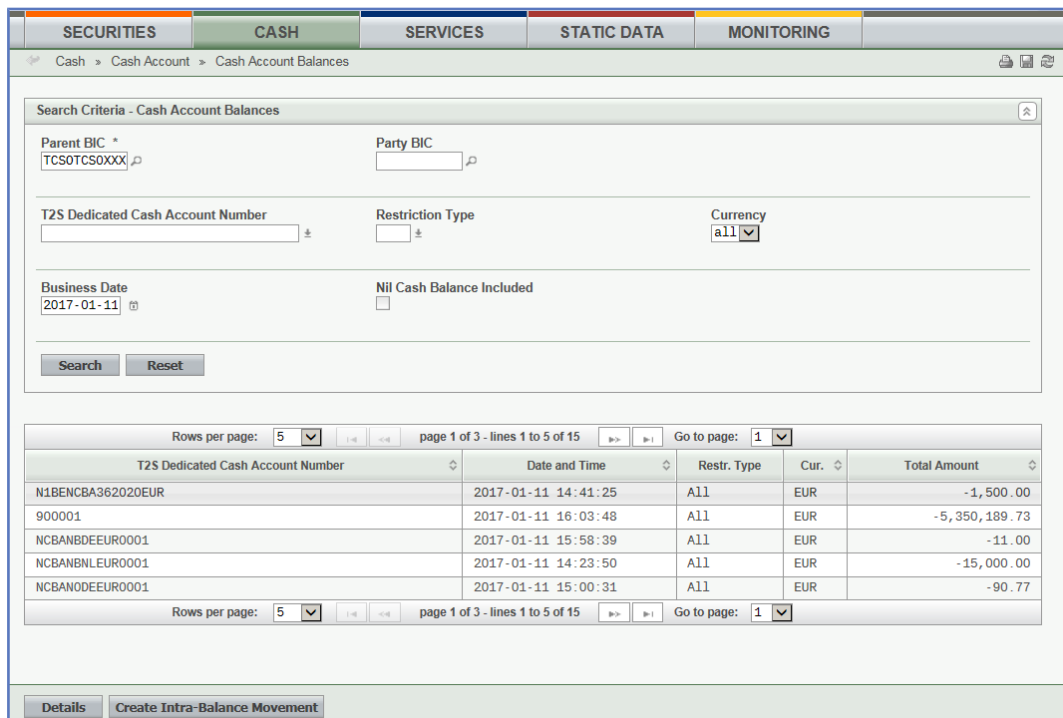

Illustration 75: T2S DCA balances – search/list screen

Field Description

| Cash Balances – Search Criteria |  |
|---------------------------------|--|
| Party BIC*                      | <p>Select the BIC of the party owning the cash balances you want to retrieve from the drop-down menu or search via the <i>magnifier</i> icon.</p> <p>You have to enter at least one field among ‘Party BIC’ and ‘Date’.</p> <p>References for error messages [ ▶ 1120]:</p> <ul style="list-style-type: none"> <li><input type="checkbox"/> QMPC032</li> <li><input type="checkbox"/> QMPC072</li> <li><input type="checkbox"/> QMPC084</li> </ul> |
| Parent BIC*                     | <p>Select the parent BIC of the CB where the above party holds the cash balances you want to retrieve from the drop-down menu.</p> <p>References for error messages [ ▶ 1120]:</p> <ul style="list-style-type: none"> <li><input type="checkbox"/> QMPC048</li> <li><input type="checkbox"/> QMPC072</li> <li><input type="checkbox"/> QMPC084</li> </ul>  |

| Cash Balances – Search Criteria   |  |
|-----------------------------------|--|
| T2S Dedicated Cash Account Number | <p>Select the number of the T2S dedicated cash account from the drop-down menu.</p> <p>If there is only one possible cash account, this field is read-only.</p> <p>References for error message [ ▶ 1120]s:</p> <ul style="list-style-type: none"> <li><input type="checkbox"/> QMPC031</li> <li><input type="checkbox"/> QMPC072</li> </ul>   |
| Restriction Type                  | <p>Select a restriction type of the cash balance.</p> <p>If you select the value 'All', all cash balances are displayed in the list.</p> <p>Reference for error message [ ▶ 1120]:</p> <ul style="list-style-type: none"> <li><input type="checkbox"/> QMPC091</li> </ul>  |
| Currency                          | <p>Select the currency of the T2S dedicated cash account from the drop-down menu. The default value is 'all'.</p> <p>References for error messages [ ▶ 1120]:</p> <ul style="list-style-type: none"> <li><input type="checkbox"/> QMPC054</li> <li><input type="checkbox"/> QMPC072</li> </ul>   |
| Date                              | <p>Enter the date of T2S dedicated cash account balance or use the <i>calendar</i> icon.</p> <p>Required format is: YYYY-MM-DD</p> <p>You have to enter at least one field among 'Party BIC' and 'Date'.</p> <p>The default value is the current business day.</p> <p>The 'Date' must be a valid business date which is earlier than or equal to the current business date.</p> <p>Reference for error message [ ▶ 1120]:</p> <ul style="list-style-type: none"> <li><input type="checkbox"/> QMPC073</li> </ul> |
| Nil Cash Balance Included         | <p>Select whether the T2S dedicated cash balances equal to zero are included.</p>  |
| Multiple Cash Balances - List     |  |
| T2S Dedicated Cash Account Number | <p>Shows the number of the T2S dedicated cash account of the cash balance.</p> <p>Reference for error message [ ▶ 1120]:</p> <ul style="list-style-type: none"> <li><input type="checkbox"/> QMPC072</li> </ul>  |

| Cash Balances – Search Criteria |   |
|---------------------------------|---|
| Date and Time                   | Shows the date and time of the cash balance (or the closest previous date and time).<br>Displayed format is: YYYY-MM-DD hh:mm:ss:µsµsµsµsµs   |
| Restriction Type                | Shows the restriction type of the cash balance.<br>Reference for error message [ ▶ 1120]:<br><input type="checkbox"/> QMPC091   |
| Currency                        | Shows the currency of the T2S dedicated cash account.<br>References for error messages [ ▶ 1120]:<br><input type="checkbox"/> QMPC054<br><input type="checkbox"/> QMPC072                     |
| Total Amount                    | Shows the total amount of the cash balance.<br>Provision of '99999...99' in case oversizing occurs in the integer part. Truncation of decimals in case oversizing occurs in the decimal part. |

## Buttons

| Buttons |  |
|---------|--|
| Search  | This function enables you to start a search according to the criteria entered. The results are displayed in a list on the same screen.<br>If the search retrieves a single record, the <i>details</i> screen is displayed directly.<br>Next screens:<br><input type="checkbox"/> T2S DCA balances - search/list screen<br><input type="checkbox"/> T2S DCA balance – details screen [ ▶ 361]<br>References for error messages [ ▶ 1120]:<br><input type="checkbox"/> QMPC031<br><input type="checkbox"/> QMPC032<br><input type="checkbox"/> QMPC048<br><input type="checkbox"/> QMPC054<br><input type="checkbox"/> QMPC072<br><input type="checkbox"/> QMPC073<br><input type="checkbox"/> QMPC084<br><input type="checkbox"/> QMPC091 |



|                               |   |
|-------------------------------|---|
| Reset                         | This function enables you to set default search criteria and blanks out all optional criteria.<br>Next screen:<br><input type="checkbox"/> <i>T2S DCA balances - search/list</i> screen                             |
| Details                       | This function enables you to display the details of the selected cash balance.<br>Next screen:<br><input type="checkbox"/> <i>T2S DCA balance - details</i> screen [▶ 361]  |
| Create Intra-Balance Movement | This function enables you to create a new restricted cash balance for the selected T2S dedicated cash account number.<br>Next screen:<br><input type="checkbox"/> <i>Intra-balance movement – new</i> screen [ 436] |

### 2.3.1.11 T2S DCA Balance - Details Screen

#### Context of Usage

This screen displays detailed information on the cash balances for a T2S dedicated cash account owner, i.e. a party which is a payment or central bank. You can check the data and proceed further by clicking on the buttons below.

During the Start of Day, when the CRDM data is being replicated in the Settlement domain, only the cash balance data available at the End-of-Day of the previous business day is displayed at the screen. The cash balance data for the new business day is available as of the end of the CRDM data replication.

During night-time, the cash balances can only be displayed in-between night-time settlement sequences.

This screen is not relevant for CSD or CSD participant users.

#### Screen Access

- Cash >> Cash Account >> Cash Account Balances >> *T2S DCA balances – search/list* screen >> Click on the *search* and/or *details* button
- Cash >> Settlement >> Intra-Balance Movements >> *Intra-balance movements – search/list* screen >> Click on the *search* and/or *details* button >> *Intra-balance movement – details* screen >> Click on the *cash balance details* button

#### Privileges

No privilege needed to use this screen.

#### References

##### User Instructions Part

This screen is part of the following business scenarios:

- View cash balances details and related postings [▶ 673]

- View cash balances details and related restrictions [▶ 674]

**Business Functionality Document**

This screen corresponds to the following business functions:

- Display T2S dedicated cash account balances (T2S.GUI.LMSE.CSH.0020)

**Screenshot**

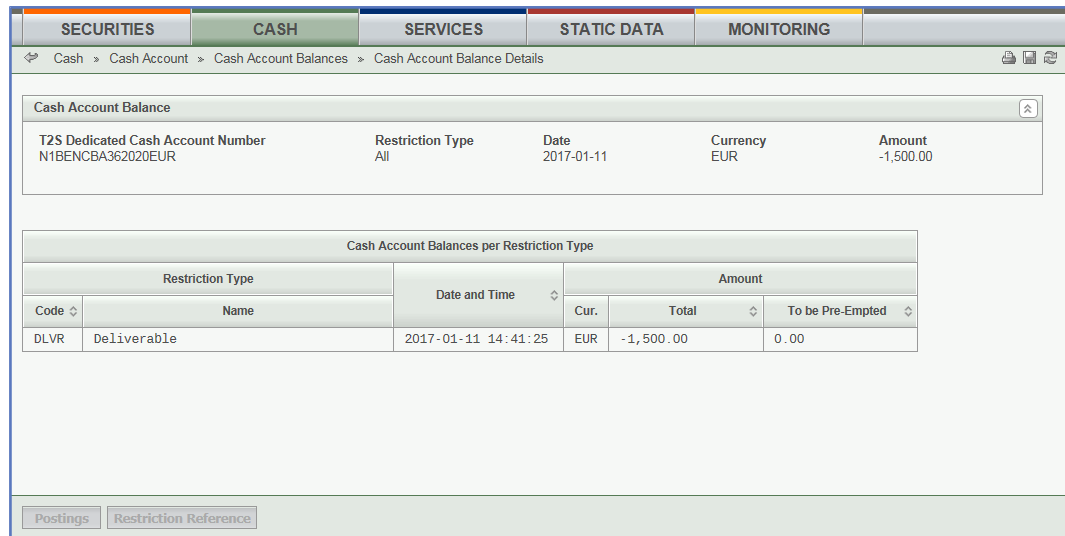

Illustration 76: T2S dedicated cash account balance – details screen

**Field**

**Description**

| Identification of Cash Balances   |  |
|-----------------------------------|--|
| T2S Dedicated Cash Account Number | Shows the number of the T2S dedicated cash account.  |
| Restriction Type                  | Shows the restriction type of the cash balance.  |
| Currency                          | Shows the currency of the T2S dedicated cash account.  |
| Total Amount                      | Shows the total amount of cash for the aggregated cash balances.<br><br>Provision of '99999...99' in case oversizing occurs in the integer part. Truncation of decimals in case oversizing occurs in the decimal part. |
| Cash Balance per Restriction Type |  |
| Restriction Type                  |  |
| Code                              | Shows the code of the restriction type of the cash balance.  |
| Name                              | Shows the name of the restriction type of the cash balance.  |
| Date and Time                     | Shows the date and time of the last movement related to the cash balance.<br><br>Displayed format is: YYYY-MM-DD hh:mm:ss:µsµsµsµsµsµs   |
| Amount                            |  |

| Identification of Cash Balances |  |
|---------------------------------|--|
| Currency                        | Shows the currency related to the T2S dedicated cash account.  |
| Total                           | Shows the total amount of the cash balance.<br>Provision of '99999...99' in case oversizing occurs in the integer part. Truncation of decimals in case oversizing occurs in the decimal part.                    |
| To be Pre-Empted                | Shows the amount of the cash balance that is to be pre-empted.<br>Provision of '99999...99' in case oversizing occurs in the integer part. Truncation of decimals in case oversizing occurs in the decimal part. |

**Buttons**

|                         |  |
|-------------------------|--|
| Postings                | This function enables you to display the cash postings for the selected cash balance.<br>Next screen:<br><input type="checkbox"/> <i>T2S DCA postings – search/list screen</i> [▶ 363]                             |
| Restrictions References | This function enables you to display the details per restriction reference for the selected cash balance.<br>Next screen:<br><input type="checkbox"/> <i>Cash restriction details – search/list screen</i> [▶ 337] |

### 2.3.1.12 T2S DCA Postings - Search/List Screen

**Context of Usage**

This screen contains a number of search fields. By inputting the relevant data, you can search for cash postings which are the individual debits and credits impacting the selected cash balance. The search results will be displayed in a list, which is sorted either by the values of the 'T2S Dedicated Account Number', 'Restriction Type', 'Date', 'Debit/Credit', 'Currency', 'Amount', 'Instruction Type', 'Internal Reference', 'Restriction Reference' or 'Date and Time' columns in ascending order (default setting).

After selecting an entry, you can proceed further by clicking on the buttons below. During night-time, the T2S DCA postings can only be displayed in-between night-time settlement sequences.

This screen is not relevant for CSD or CSD participant users.

**Screen Access**

Cash >> Cash Account >> Cash Account Postings

- Cash >> Cash Account >> Cash Account Balances >> **T2S DCA balances – search/list screen** >> Click on the *search* and/or *details* button >> **T2S DCA balance – details screen** >> Click on the *postings* button

**Privileges**

To use this screen, you need the following privilege [**▶ 903**]:

- T2S dedicated cash account posting query

**References**

**User Instructions Part**

This screen is part of the following business scenario:

- View cash balances details and related postings [**▶ 673**]

**Business Functionality Document**

This screen corresponds to the following business functions:

- Query T2S dedicated cash account postings (T2S.GUI.LMSE.CSH.0030)
- Display T2S dedicated cash account postings (T2S.GUI.LMSE.CSH.0040)

**Screenshot**

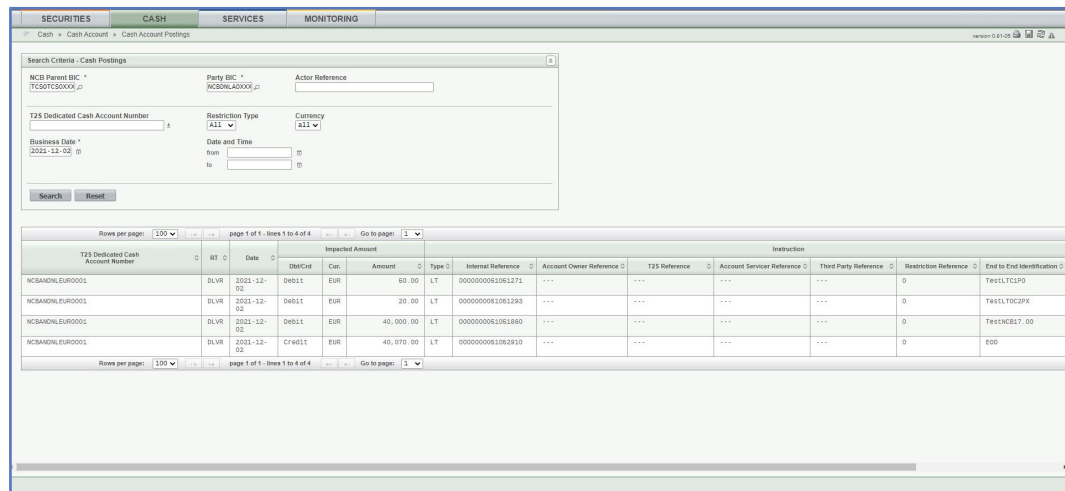

Illustration 77: T2S DCA postings – search/list screen

**Field**

**Description**

| Cash Postings - Search Criteria |   |
|---------------------------------|---|
| Actor Reference                 | <p>You can choose to enter one of the following references depending on whether you are querying on cash movements related to a settlement instruction or a liquidity transfer:</p> <ul style="list-style-type: none"> <li><input type="checkbox"/> For a settlement instruction:                             <ul style="list-style-type: none"> <li><input type="checkbox"/> Account Owner Reference</li> <li><input type="checkbox"/> Account Servicer Reference</li> <li><input type="checkbox"/> T2S Reference</li> <li><input type="checkbox"/> Third Party Reference</li> </ul> </li> <li><input type="checkbox"/> For a liquidity transfer:                             <ul style="list-style-type: none"> <li><input type="checkbox"/> End to End Identification</li> </ul> </li> </ul> |

| Cash Postings - Search Criteria   |   |
|-----------------------------------|---|
|                                   | <p><input type="checkbox"/> Technical Identifier of LT</p> <p>If you fill in the Actor Reference, only Liquidity transfers or Settlement instructions related to this reference are returned,</p> <p>When the Actor reference is not found in SI or LT, the message “No record found” is displayed.</p>   |
| Party BIC*                        | <p>You can choose to either enter the BIC of the party owning the cash account or to select it from the suggested items in the drop-down menu.</p> <p>If you have accessed this screen via the T2S DCA balance – details screen, this field is already filled in.</p> <p>References for error messages [ ▶ 1121]:</p> <p><input type="checkbox"/> QMPC032</p> <p><input type="checkbox"/> QMPC072</p> |
| NCB Parent BIC*                   | <p>You can choose to either enter the BIC of the CB where the above party holds the cash account or to select it from the suggested items in the drop-down menu. If you have accessed this screen via the T2S DCA balance – details screen, this field is already filled in.</p> <p>Reference for error message [ ▶ 1121]:</p> <p><input type="checkbox"/> QMPC072</p>                                |
| T2S Dedicated Cash Account Number | <p>Select the number of the T2S dedicated cash account from the drop-down menu. The default value is ‘All’.</p> <p>If there is only one possible cash account, this field is read-only.</p> <p>If you have accessed this screen via the T2S DCA balance – details screen, this field is already filled in.</p> <p>Reference for error message [ ▶ 1121]:</p> <p><input type="checkbox"/> QMPC072</p>  |
| Restriction Type                  | <p>You can choose to either enter the restriction type of the cash posting or to select it from the suggested items in the drop-down menu.</p> <p>If you select the value ‘All’, the postings of all restriction types are displayed in the list.</p>   |

| Cash Postings - Search Criteria |   |
|---------------------------------|---|
|                                 | <p>If you have accessed this screen via the T2S DCA balance – details screen, this field is already filled in.</p> <p>Reference for error message [ ▶ 1121]:</p> <ul style="list-style-type: none"> <li><input type="checkbox"/> QMPC091</li> </ul>   |
| Currency                        | <p>Select the currency of the T2S dedicated cash account from the drop-down menu. The default value is 'All'.</p> <p>If you have accessed this screen via the T2S DCA balance – details screen, this field is already filled in.</p> <p>References for error messages [ ▶ 1121]:</p> <ul style="list-style-type: none"> <li><input type="checkbox"/> QMPC054</li> <li><input type="checkbox"/> QMPC072</li> </ul>   |
| Date*                           | <p>Enter the date of the cash postings or use the <i>calendar</i> icon.</p> <p>The default value is the current business day.</p> <p>Required format is: YYYY-MM-DD</p> <p>The 'Date' must be a valid business date earlier than or equal to the current business date.</p> <p>If you have accessed this screen via the T2S DCA balance – details screen, this field is already filled in.</p> <p>References for error messages [ ▶ 1121]:</p> <ul style="list-style-type: none"> <li><input type="checkbox"/> QMPC016</li> <li><input type="checkbox"/> QMPC073</li> </ul> |
| Date and Time from              | <p>Enter the starting date and time of the cash postings or use the <i>calendar</i> icon.</p> <p>Required format is: YYYY-MM-DD hh:mm</p> <p>The 'Date and Time from' must be a valid business date earlier than or equal to the current business date and time.</p> <p>Reference for error message [ ▶ 1121]:</p> <ul style="list-style-type: none"> <li><input type="checkbox"/> QMPC073</li> </ul>   |
| Date and Time to                | <p>Enter the ending date and time of the cash postings or use the <i>calendar</i> icon.</p> <p>Required format is: YYYY-MM-DD hh:mm</p>   |

| Cash Postings - Search Criteria   |  |
|-----------------------------------|--|
|                                   | The 'Date and Time to' must be a valid business date earlier than or equal to the current business date and time. The date and time must be equal to or later than the 'Date and Time from'. |
| Cash Postings - List              |  |
| T2S Dedicated Cash Account Number | Shows the number of the T2S dedicated cash account of the cash posting.<br>Reference for error message [ ▶ 1121]:<br><input type="checkbox"/> QMPC072  |
| Restriction Type                  | Shows the restriction type of the cash posting.<br>Reference for error message [ ▶ 1121]:<br><input type="checkbox"/> QMPC091  |
| Date                              | Shows the date of the cash posting.<br>Displayed format is: YYYY-MM-DD<br>References for error messages [ ▶ 1121]:<br><input type="checkbox"/> QMPC016<br><input type="checkbox"/> QMPC073   |
| Impacted Amount                   |  |
| Debit/Credit Indicator            | Shows the debit/credit indicator related to the cash posting from the possible values:<br><input type="checkbox"/> D (for debit)<br><input type="checkbox"/> C (for credit)                  |
| Currency                          | Shows the currency of the T2S dedicated cash account.<br>References for error messages [ ▶ 1121]:<br><input type="checkbox"/> QMPC054<br><input type="checkbox"/> QMPC072                    |
| Amount                            | Shows the amount of the cash posting.  |
| Instruction                       |  |
| Account Owner Reference           | Shows the Account Owner Transaction Identification of the instruction related to the cash posting.   |
| T2S Reference                     | Shows the Market Infrastructure Transaction Identification of the instruction related to the cash posting.   |
| Account Servicer Reference        | Shows the Account Servicer Transaction Identification of the instruction related to the cash posting   |

| Cash Postings - Search Criteria |  |
|---------------------------------|--|
| Third Party Reference           | Shows the Processing Identification of the instruction related to the cash posting.  |
| End to End Id                   | Shows the End to End Identification of the Liquidity Transfer related to the cash posting.   |
| Technical Id                    | Shows the Technical Identifier of the Liquidity Transfer related to the cash posting.  |
| Type                            | Shows the type of instruction related to the cash posting from the possible values: <ul style="list-style-type: none"> <li><input type="checkbox"/> LT (for liquidity transfer)</li> <li><input type="checkbox"/> SI (for settlement instruction)</li> <li><input type="checkbox"/> SR (for settlement restriction)</li> </ul> |
| Internal Reference              | Shows the T2S internal reference of the instruction related to the cash posting.   |
| Restriction Reference           | Shows the restriction reference related to the cash posting.   |
| Date and Time                   | Shows the date and time of the cash posting.<br>Displayed format is: YYYY-MM-DD hh:mm:ss:µsµsµsµsµs  |

**Buttons**

| Buttons |   |
|---------|---|
| Search  | <p>This function enables you to start a search according to the criteria entered. The results are displayed in a list on the same screen.</p> <p>Next screen:</p> <ul style="list-style-type: none"> <li><input type="checkbox"/> T2S DCA postings – search/list screen</li> </ul> <p>References for error messages [ ▶ 1121]:</p> <ul style="list-style-type: none"> <li><input type="checkbox"/> QMPC016</li> <li><input type="checkbox"/> QMPC032</li> <li><input type="checkbox"/> QMPC054</li> <li><input type="checkbox"/> QMPC072</li> <li><input type="checkbox"/> QMPC073</li> <li><input type="checkbox"/> QMPC091</li> </ul> |
| Reset   | <p>This function enables you to set default search criteria and blanks out all optional criteria.</p> <p>Next screen:</p> <ul style="list-style-type: none"> <li><input type="checkbox"/> T2S DCA postings – search/list screen</li> </ul>  |



## 2.3.1.13 Total Collateral Values per T2S Dedicated Cash Account - Search/List Screen

### Context of Usage

This screen contains a number of search fields. By inputting the relevant data, you can search for the total collateral value of securities on stock which are eligible for auto-collateralisation for those T2S dedicated cash accounts that match the specified selection criteria. The search results will be displayed in a list, which is sorted by the values of the 'Party BIC' column in ascending order (default setting). After selecting an entry, you can proceed further by clicking on the buttons below.

During the Start of Day, when the CRDM data is being replicated in the Settlement domain, only the total collateral value per T2S dedicated cash account data available at the End-of-Day of the previous business day is displayed at the screen. The total collateral value per T2S dedicated cash account data for the new business day is available as of the end of the CRDM data replication.

The screen can be used in the following contexts:

- CB users (CB as credit provider) can view the total collateral value of securities associated to the T2S dedicated cash accounts of their payment banks. This is the collateral value that payments banks can use as a guarantee for central bank collateralisation.
- Payment bank users (payment bank as credit consumer) can view the total collateral value of their own securities associated to their T2S dedicated cash accounts. This is the collateral value that the payment bank can use as a guarantee for central bank collateralisation.
- Payment bank users (payment bank as credit provider) can view the total collateral value of the clients' securities associated to the payment bank's T2S dedicated cash accounts. This is the collateral value that the payment bank's clients can use as a guarantee for client collateralisation.
- Payment bank client users (payment bank client as credit consumer) can view the total collateral value of their securities associated to the T2S dedicated cash account of their payment bank. This is the collateral value that the payment bank's client can use as a guarantee for client collateralisation.

There is no usage restriction for this screen.

### Screen Access

- Cash >> Cash Account >> Total Collateral Values (T2S DCA)
- Securities >> Securities Account >> Total Collateral Values (T2S DCA)

### Privileges

To use this screen, you need the following privilege [[▶ 904](#)]:

- Total collateral value per T2S dedicated cash account query

**References**

**User Instructions Part**

This screen is not part of a business scenario.

**Business Functionality Document**

This screen corresponds to the following business functions:

- Query total current collateral value (per T2S dedicated cash account) (T2S.GUI.LMSE.CSH.0090)
- Display total current collateral value (per T2S dedicated cash account) (T2S.GUI.LMSE.CSD.0100)

**Screenshot**

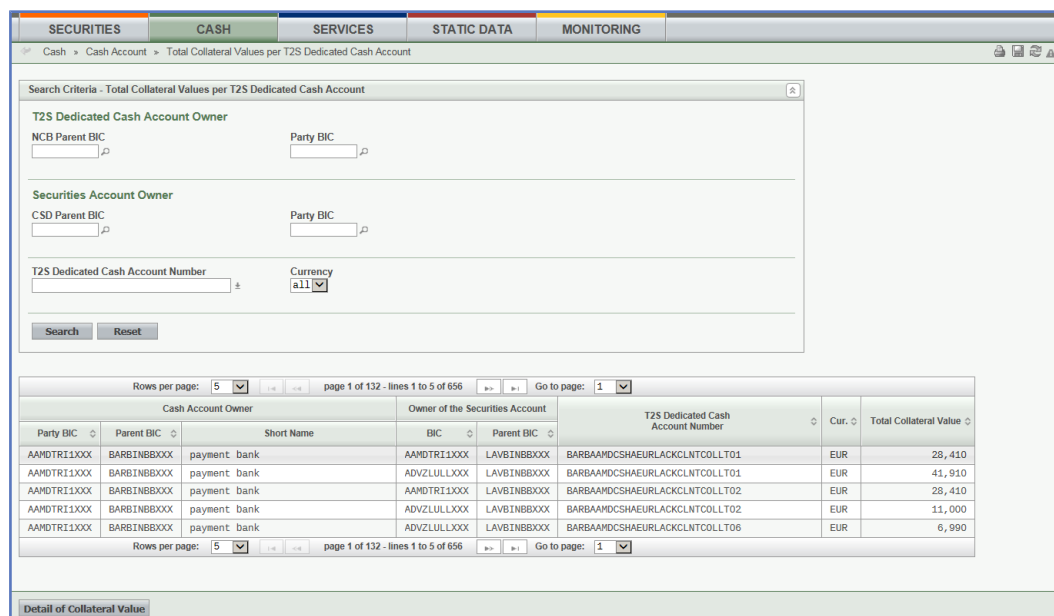

Illustration 78: Total collateral value per T2S dedicated cash account – search/list screen

**Field Description**

| Total Collateral Value per T2S Dedicated Cash Account - Search Criteria |   |
|---|---|
| <b>T2S Dedicated Cash Account Owner</b>                                 |   |
| Party BIC   | Select the BIC of the party owning the T2S dedicated cash account from the drop-down menu or search via the <i>magnifier</i> icon.<br><br>Reference for error message: [ 1123]<br><br><input type="checkbox"/> QMPC032  |
| NCB Parent BIC  | Select the BIC of the national central bank which is the parent of the party owning the T2S dedicated cash account from the drop-down menu or search via the <i>magnifier</i> icon.<br><br>Reference for error message: [ 1123]<br><br><input type="checkbox"/> QMPC032 |
| <b>Securities Account Owner</b>   |   |

| Total Collateral Value per T2S Dedicated Cash Account - Search Criteria |  |
|---|--|
| Party BIC   | Select the BIC of the party owning the securities account from the drop-down menu or search via the <i>magnifier</i> icon.<br>References for error messages: [▶ 1123]<br><input type="checkbox"/> QMPC032<br><input type="checkbox"/> QMPC084                                |
| CSD Parent BIC  | Select the BIC of the CSD which is the parent of the party owning the securities account from the drop-down menu or search via the <i>magnifier</i> icon.<br>References for error messages: [▶ 1123]<br><input type="checkbox"/> QMPC032<br><input type="checkbox"/> QMPC084 |
| T2S Dedicated Cash Account Number                                       | Select the number of the T2S dedicated cash account from the drop-down menu.<br>If there is only one possible T2S dedicated cash account for your privileges, this field is already filled in.<br>Reference for error message: [▶ 1123]<br><input type="checkbox"/> QMPC031  |
| Currency  | Select the currency of the T2S dedicated cash account(s) from the drop-down menu. The default value is 'all'.<br>Reference for error message: [▶ 1123]<br><input type="checkbox"/> QMPC054   |
| Total Collateral Value per T2S Dedicated Cash Account - List            |  |
| Cash account owner  |  |
| Party BIC   | Shows the BIC of the party owning the T2S dedicated cash account.<br>Reference for error message: [▶ 1123]<br><input type="checkbox"/> QMPC032   |
| Parent BIC  | Shows the BIC of the national central bank which is the parent of the party owning the T2S dedicated cash account.<br>Reference for error message: [▶ 1123]<br><input type="checkbox"/> QMPC032  |
| Party Short Name  | Shows the short name of the party owning the T2S dedicated cash account.   |

| Total Collateral Value per T2S Dedicated Cash Account - Search Criteria |   |
|---|---|
| T2S Dedicated Cash Account Number                                       | Shows the number of the T2S dedicated cash account.<br>Reference for error message: [ 1123]<br><input type="checkbox"/> QMPC031   |
| Currency  | Shows the currency of the T2S dedicated cash account.<br>Reference for error message: [ 1123]<br><input type="checkbox"/> QMPC054   |
| Securities Account Owner  |   |
| Party BIC   | Shows the BIC of the securities account owner of the securities account that holds the valuated securities  |
| Parent BIC  | Shows the parent BIC of the securities account owner  |
| Total Collateral Value  | Shows the collateral value of the aggregated securities positions per T2S dedicated cash account.<br>Provision of '99999...99' in case oversizing occurs in the integer part. Truncation of decimals in case oversizing occurs in the decimal part. |

## Buttons

| Buttons |  |
|---------|--|
| Search  | This function enables you to start a search according to the criteria entered. The results are displayed in a list on the same screen.<br>If the search retrieves a single record, the <i>details</i> screen is displayed directly.<br>References for error messages: [ 1123]<br><input type="checkbox"/> QMPC031<br><input type="checkbox"/> QMPC032<br><input type="checkbox"/> QMPC054<br><input type="checkbox"/> QMPC084<br>Next screens:<br><input type="checkbox"/> <i>Total collateral value per T2S dedicated cash account – search/list screen</i><br><input type="checkbox"/> <i>Collateral value per T2S dedicated cash account and security – search/list screen [ 344]</i> |
| Reset   | This function enables you to set default search criteria and blanks out all optional criteria.<br>Next screen:   |

|                            |  |
|----------------------------|--|
|                            | <input type="checkbox"/> <i>Total collateral value per T2S dedicated cash account – search/list screen</i>   |
| Detail of Collateral Value | <p>This function enables you to display the details of the collateral value for the selected T2S dedicated cash account.</p> <p>Next screen:</p> <input type="checkbox"/> <i>Collateral value per T2S dedicated cash account and security – search/list screen [▶ 344]</i> |

## 2.3.2 Liquidity

### 2.3.2.1 Data Changes - Search/List Screen

See *Data Changes – Search/List Screen* [▶ 607].

### 2.3.2.2 Data Change - Details Screen

See *Data Changes – Details Screen* [▶ 611].

### 2.3.2.3 Immediate Liquidity Transfers - Search/List Screen

#### Context of Usage

This screen contains a number of search fields. By inputting the relevant data, you can search for immediate liquidity transfer orders. The search results will be displayed in a list. If you search via 'Parent BIC' or 'Party BIC', the list will be sorted by the values of the 'T2S Dedicated Cash Account Number' column in ascending order (default setting). If you search via another search parameter, the list will be sorted by the values of the 'Settlement Date and Time' column in ascending order (default setting). After the initial sorting, you have the possibility to rearrange the list according to your preferences by selecting another 'Sort by'. After selecting an entry, you can proceed further by clicking on the buttons below.

This screen is not relevant for CSD, CSD participants and external CSD users.

#### Screen Access

Cash >> Liquidity >> Immediate Liquidity Transfers

#### Privileges

To use this screen, you need the following privileges [▶ 884]:

- Immediate liquidity transfer order list query
- Immediate liquidity transfer order detail query

#### References

##### User Instructions Part

This screen is part of the following business scenarios:

- Create a new immediate liquidity transfer order

- Copy an immediate liquidity transfer order [▶ 671]
- View immediate liquidity transfer order details [▶ 675]

**Business Functionality Document**

This screen corresponds to the following business functions:

- Query immediate liquidity transfer instructions (T2S.GUI.LMSE.INX.0010)
- Display immediate liquidity transfer instructions list (T2S.GUI.LMSE.INX.0020)

**Screenshot**

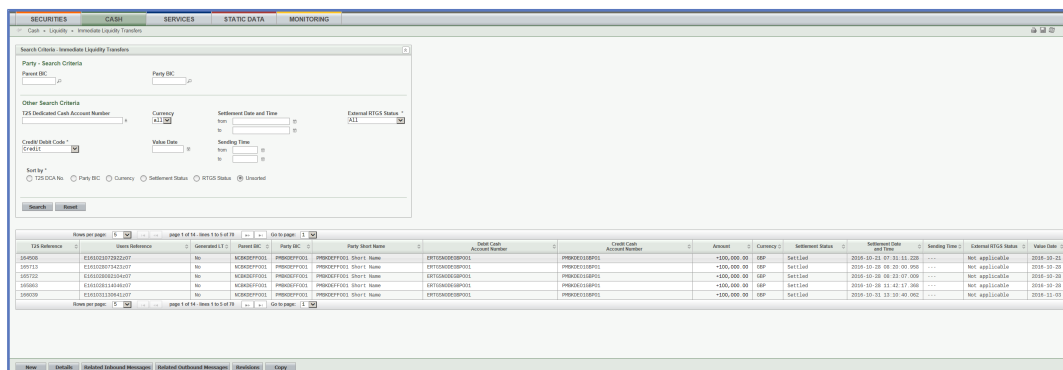

Illustration 79: Immediate liquidity transfer orders - search/list screen

**Field Description**

| Immediate Liquidity Transfer Orders – Search Criteria |   |
|---|---|
| <b>Party</b>  |   |
| Parent BIC  | Select the parent BIC of the party.<br>References for error messages [▶ 990]:<br><input type="checkbox"/> QMPC072<br><input type="checkbox"/> QMPC084   |
| Party BIC   | Select the BIC of the party.<br>References for error messages [▶ 990]:<br><input type="checkbox"/> QMPC032<br><input type="checkbox"/> QMPC072<br><input type="checkbox"/> QMPC084  |
| <b>Other Search Criteria</b>                          |   |
| T2S Dedicated Cash Account Number                     | Select the T2S dedicated cash account which has been debited or credited from the drop-down menu. The default value is 'All'.<br>References for error messages [▶ 990]:<br><input type="checkbox"/> QMPC031<br><input type="checkbox"/> QMPC072 |

| Immediate Liquidity Transfer Orders – Search Criteria |   |
|---|---|
|   | If you have the privilege for only one T2S dedicated cash account, this field is already filled in.   |
| Debit/Credit Indicator*                               | <p>Select the credit/debit code from the possible values:</p> <ul style="list-style-type: none"> <li><input type="checkbox"/> Credit</li> <li><input type="checkbox"/> Credit and Debit (default value)</li> <li><input type="checkbox"/> Debit</li> </ul> <p>Select credit if you want to search for liquidity transfer orders which have credited a T2S dedicated cash account.</p> <p>Select debit if you want to search for liquidity transfer orders which have debited a T2S dedicated cash account.</p>                |
| Currency  | <p>Select the currency assigned to the T2S dedicated cash account from the drop-down menu. The default value is 'all'.</p> <p>References for error messages [ ▶ 990]:</p> <ul style="list-style-type: none"> <li><input type="checkbox"/> QPMC054</li> <li><input type="checkbox"/> QPMC072</li> </ul> <p>If you have first selected the 'T2S Dedicated Cash Account Number', this field is already filled in.</p>  |
| Settlement Date and Time - from                       | <p>Enter the date and time from which the liquidity transfer is settled or use the <i>calendar</i> icon.</p> <p>Required format is: YYYY-MM-DD hh:mm:ss</p> <p>References for error messages [ ▶ 990]:</p> <ul style="list-style-type: none"> <li><input type="checkbox"/> QMPC015</li> <li><input type="checkbox"/> QMPC016</li> </ul> <p>The 'Settlement Date and Time – from' cannot be earlier than 90 days before the current business day and must be earlier than or equal to the 'Settlement Date and Time – to'.</p> |
| Settlement Date and Time - to                         | <p>Enter the date and time until which the liquidity transfer is settled or use the <i>calendar</i> icon.</p> <p>Required format is: YYYY-MM-DD hh:mm:ss</p> <p>References for error messages [ ▶ 990]:</p> <ul style="list-style-type: none"> <li><input type="checkbox"/> QMPC015</li> <li><input type="checkbox"/> QMPC016</li> </ul>  |

| Immediate Liquidity Transfer Orders – Search Criteria |   |
|---|---|
|   | <input type="checkbox"/> QMPC097<br>The 'Settlement Date and Time - to' cannot be earlier than 90 days before the current business day and must be earlier than or equal to the current business day.   |
| Value Date  | Enter the value date of the liquidity transfer or use the <i>calendar</i> icon.<br>Required format is: YYYY-MM-DD<br>The 'Value Date' cannot be earlier than 90 days before the current business day or later than the current business day.<br>If you do not select a date, this field is filled in with the current business day.                                     |
| Sending Time - from                                   | Enter the time from which the outbound liquidity transfer was sent to the RTGS.<br>Required format is: hh:mm:ss   |
| Sending Time - to                                     | Enter the time until which the outbound liquidity transfer was sent to the RTGS.<br>Required format is: hh:mm:ss  |
| External RTGS Status*                                 | Select the external RTGS status from the possible values:<br><input type="checkbox"/> Not executed<br><input type="checkbox"/> Not applicable (default value)<br><input type="checkbox"/> RTGS rejection<br><input type="checkbox"/> RTGS confirmation<br><input type="checkbox"/> Rebooking  |
| Sort by   | Select the category by which you want to sort the list from the possible values:<br><input type="checkbox"/> T2S DCA No. (default value if you have searched via 'Parent BIC' or 'Party BIC')<br><input type="checkbox"/> Party BIC<br><input type="checkbox"/> Currency<br><input type="checkbox"/> Settlement status<br><input type="checkbox"/> External RTGS status |



| Immediate Liquidity Transfer Orders – Search Criteria    |   |
|--|---|
|  | <input type="checkbox"/> Unsorted (Default value if you have searched via the other search parameters. Unsorted means that the list is sorted by the values of the ‘Settlement Date and Time’ column.)  |
| Immediate Liquidity Transfer Orders - List <sup>16</sup> |   |
| T2S Dedicated Cash Account Number                        | <p>Shows the T2S dedicated cash account which has been debited or credited.</p> <p>References for error messages [ ▶ 990]:</p> <ul style="list-style-type: none"> <li><input type="checkbox"/> QMPC031</li> <li><input type="checkbox"/> QMPC072</li> </ul> <p>If you sort the list by that value, the screen is divided into different sections grouped by T2S dedicated cash account numbers.</p>   |
| Party BIC  | <p>Shows the BIC of the party.</p> <p>References for error messages [ ▶ 990]:</p> <ul style="list-style-type: none"> <li><input type="checkbox"/> QMPC032</li> <li><input type="checkbox"/> QMPC072</li> <li><input type="checkbox"/> QMPC084</li> </ul> <p>If you sort the list by that value, the screen is divided into different sections grouped by party.</p>   |
| Currency   | <p>Shows the currency of the amount to be transferred.</p> <p>References for error messages [ ▶ 990]:</p> <ul style="list-style-type: none"> <li><input type="checkbox"/> QPMC054</li> <li><input type="checkbox"/> QPMC072</li> </ul> <p>If you sort the list by that value, the screen is divided into different sections grouped by currency.</p>  |
| Settlement Status  | <p>Shows the settlement status of liquidity transfers.</p> <p>If the liquidity transfer is internal or outbound, it shows the settlement status from the possible values:</p> <ul style="list-style-type: none"> <li><input type="checkbox"/> Not executed (SNXE)</li> <li><input type="checkbox"/> Unsettled (SUNS)</li> <li><input type="checkbox"/> Partially settled (SPAS)</li> <li><input type="checkbox"/> Settled (SSET)</li> </ul> |

16 Please note that the described functionality won't be available before CSLD go-live.

| Immediate Liquidity Transfer Orders – Search Criteria |  |
|---|--|
|   | <p>If the liquidity transfer is inbound, it shows the settlement status from the possible values:</p> <ul style="list-style-type: none"> <li><input type="checkbox"/> Not executed</li> <li><input type="checkbox"/> Settled</li> </ul> <p>If you sort the list by that value, the screen is divided into different sections grouped by settlement status.</p>   |
| External RTGS Status                                  | <p>Shows the external RTGS status of the liquidity transfer from the possible values:</p> <ul style="list-style-type: none"> <li><input type="checkbox"/> Not executed (RNXE)</li> <li><input type="checkbox"/> Not applicable (RNAP)</li> <li><input type="checkbox"/> RTGS rejection (RREJ)</li> <li><input type="checkbox"/> RTGS confirmation (RCON)</li> </ul> <p>If the liquidity transfer is internal, this field is always filled in with 'not applicable'.</p> <p>If you sort the list by that value, the screen is divided into different sections grouped by settlement status.</p> |
| T2S Reference   | Shows the unique identification assigned by T2S to the respective immediate liquidity transfer.  |
| Settlement Date and Time                              | <p>Shows the date and time when the immediate liquidity transfer was settled.</p> <p>Displayed format is: YYYY-MM-DD hh:mm:ss</p> <p>References for error messages [ ▶ 990]:</p> <ul style="list-style-type: none"> <li><input type="checkbox"/> QMPC015</li> <li><input type="checkbox"/> QMPC016</li> <li><input type="checkbox"/> QMPC097</li> </ul>  |
| Parent BIC  | <p>Shows the BIC of the CB that operates the T2S dedicated cash account.</p> <p>References for error messages [ ▶ 990]:</p> <ul style="list-style-type: none"> <li><input type="checkbox"/> QMPC072</li> <li><input type="checkbox"/> QMPC084</li> </ul>   |
| T2S Dedicated Cash Account Number Debit               | <p>Shows the cash account to be debited.</p> <p>If the liquidity transfer is internal or outbound, the cash account is a T2S dedicated cash account.</p>   |

| Immediate Liquidity Transfer Orders – Search Criteria |   |
|---|---|
|   | <p>If the liquidity transfer is inbound, the cash account is an External RTGS account, Main Cash Account, RTGS DCA, CLM CB Account, RTGS CB Account or TIPS Account</p> <p>If you sort the list by that value, the screen is divided into different sections grouped by debit cash account numbers.</p>   |
| T2S Dedicated Cash Account Number Credit              | <p>Shows the cash account to be credited.</p> <p>If the liquidity transfer is internal or inbound, the cash account is a T2S dedicated cash account.</p> <p>If the liquidity transfer is outbound, the cash account is an External RTGS account, Main Cash Account, RTGS DCA, CLM CB Account, RTGS CB Account or TIPS Account.</p> <p>If you sort the list by that value, the screen is divided into different sections grouped by credit cash account numbers.</p> |
| Amount  | <p>Shows the amount in respect of the settlement status.</p> <p>If the settlement status is set to 'Not executed' or 'Unsettled', the instructed amount is displayed.</p> <p>If the settlement status is set to 'Partially settled' or 'Settled', the transferred amount is displayed.</p>  |
| Interface Sending Date and Time                       | <p>Shows the time when the outbound liquidity transfer was sent to the RTGS.</p> <p>Displayed format is: hh:mm:ss</p>   |
| Value Date  | <p>Shows the value date of the liquidity transfer.</p> <p>Displayed format is: YYYY-MM-DD</p>   |

## Buttons

|        |  |
|--------|--|
| Search | <p>This function enables you to start a search according to the criteria entered. The results are displayed in a list on the same screen.</p> <p>If the search retrieves a single record, the <i>details</i> screen is displayed directly.</p> <p>Next screens:</p> <ul style="list-style-type: none"> <li><input type="checkbox"/> <i>Immediate liquidity transfer orders – search/list</i> screen</li> <li><input type="checkbox"/> <i>Immediate liquidity transfer order – details</i> screen</li> </ul> <p>[ ▶ 381]</p> <p>References for error messages [ ▶ 990]:</p> |
|--------|--|

|                           |   |
|---------------------------|---|
|                           | <ul style="list-style-type: none"><li><input type="checkbox"/> QMPC015</li><li><input type="checkbox"/> QMPC031</li><li><input type="checkbox"/> QMPC032</li><li><input type="checkbox"/> QMPC054</li><li><input type="checkbox"/> QMPC072</li><li><input type="checkbox"/> QMPC084</li></ul>   |
| Reset                     | <p>This function enables you to set default search criteria and blanks out all optional criteria.</p> <p>Next screen:</p> <ul style="list-style-type: none"><li><input type="checkbox"/> <i>Immediate liquidity transfer orders – search/list</i> screen</li></ul>  |
| Details                   | <p>This function enables you to display the details of the selected immediate liquidity transfer.</p> <p>Next screen:</p> <ul style="list-style-type: none"><li><input type="checkbox"/> <i>Immediate liquidity transfer order – details</i> screen [▶ 381]</li></ul>   |
| New                       | <p>This function enables you to create a new immediate liquidity transfer.</p> <p>Next screen:</p> <ul style="list-style-type: none"><li><input type="checkbox"/> <i>Immediate liquidity transfer order – new</i> screen [▶ 386]</li></ul>  |
| Related Inbound Messages  | <p>This function enables you to display the inbound messages related to the selected immediate liquidity transfer.</p> <p>Next screens:</p> <ul style="list-style-type: none"><li><input type="checkbox"/> <i>Inbound messages – search/list</i> screen [▶ 628] (if the immediate liquidity transfer is linked to more than one inbound message)</li><li><input type="checkbox"/> <i>Inbound message – details</i> screen [▶ 635] (if the immediate liquidity transfer is linked to one inbound message only)</li></ul> |
| Related Outbound Messages | <p>This function enables you to display the outbound messages related to the selected immediate liquidity transfer.</p> <p>Next screens:</p> <ul style="list-style-type: none"><li><input type="checkbox"/> <i>Outbound messages – search/list</i> screen [▶ 645] (if the immediate liquidity transfer is linked to more than one outbound message)</li></ul>   |

|           |  |
|-----------|--|
|           | <ul style="list-style-type: none"> <li><input type="checkbox"/> <i>Outbound message - details</i> screen [▶ 653] (if the immediate liquidity transfer is linked to one outbound message only)</li> </ul>   |
| Revisions | <p>This function enables you to display the revisions of the selected immediate liquidity transfer order.</p> <p>Next screen:</p> <ul style="list-style-type: none"> <li><input type="checkbox"/> <i>Revisions/audit trail - list</i> screen</li> </ul>                                    |
| Copy      | <p>This function enables you to copy fields to create a new immediate liquidity transfer order with the same attributes.</p> <p>Next screen:</p> <ul style="list-style-type: none"> <li><input type="checkbox"/> <i>Immediate liquidity transfer order – new</i> screen [▶ 386]</li> </ul> |

### 2.3.2.4 Immediate Liquidity Transfer - Details Screen

**Context of Usage**

This screen displays detailed information on the selected liquidity transfer. You can check the data and proceed further by clicking on the buttons below.

This screen is not relevant for CSD participants and external CSD users.

**Screen Access**

Cash >> Liquidity >> Immediate Liquidity Transfers >> *Immediate liquidity transfer orders – search/listscreen* >> Click on the *search* and/or *details* button

**Privileges**

To use this screen, you need the following privileges [▶ 883]:

- Immediate liquidity transfer order detail query
- Immediate liquidity transfer order audit trail list query

**References**

**User Instructions Part**

This screen is part of the following business scenario:

- View immediate liquidity transfer order details [▶ 675]

**Business Functionality Document**

This screen corresponds to the following business function:

- Display immediate liquidity transfer instruction details (T2S.GUI.LMSE.INX.0030)

Screenshot

Illustration 80: Immediate liquidity transfer - details screen

Field

Description

| General Information                     |  |
|---|--|
| Instructed Settlement Amount            | Shows the amount originally stated in the settlement instruction.                      |
| Transferred Settlement Amount           | Shows the total amount settled.  |
| Currency                                | Shows the currency assigned to the T2S dedicated cash account.                         |
| Settlement Date and Time                | Shows the date and time of the settlement.<br>Displayed format is: YYYY-MM-DD hh:mm:ss |
| T2S Dedicated Cash Account Number Debit | Shows the T2S dedicated cash account to be debited.                                    |

| General Information                      |  |
|--|--|
| T2S Dedicated Cash Account Number Credit | Shows the T2S dedicated cash account to be credited.   |
| Value Date                               | Shows the value date of the immediate liquidity transfer.<br>Displayed format is: YYYY-MM-DD   |
| Sending Time                             | Shows the time when the liquidity transfer was sent to the middleware.<br>Displayed format is: hh:mm:ss<br>If the liquidity transfer is internal, this field is not filled.  |
| Technical Information                    |  |
| T2S Reference                            | Shows the identification of the liquidity transfer assigned by T2S.  |
| User Reference                           | Shows the identification of the liquidity transfer assigned by the T2S actor.  |
| T2S generated                            | Shows whether a liquidity transfer was generated by T2S from the possible values:<br><input type="checkbox"/> No (i.e. immediate liquidity transfer)<br><input type="checkbox"/> Yes (i.e. standing or predefined order)<br>If the value is set to 'Yes', this field also contains the standing or predefined order identification.                    |
| Party Information                        |  |
| Parent BIC                               | Shows the parent BIC of the party.   |
| Party BIC                                | Shows the BIC of the party.  |
| Party Short Name                         | Shows the short name of the party.   |
| Current Status Information               |  |
| Settlement Status                        | Shows the current settlement status of internal, inbound and outbound liquidity transfers from the possible values:<br><input type="checkbox"/> Settled (for inbound liquidity transfers this is the only possible value)<br><input type="checkbox"/> Partially settled<br><input type="checkbox"/> Unsettled<br><input type="checkbox"/> Not executed |
| Settlement Date and Time                 | Shows the date and time of the respective settlement status.   |

| General Information                |  |
|------------------------------------|--|
|                                    | Displayed format is: YYYY-MM-DD hh:mm:ss   |
| External RTGS Status               | Shows the current RTGS status of the instruction from the possible values: <ul style="list-style-type: none"> <li><input type="checkbox"/> RTGS rejection</li> <li><input type="checkbox"/> RTGS confirmation</li> <li><input type="checkbox"/> Not executed</li> <li><input type="checkbox"/> Not applicable</li> <li><input type="checkbox"/> Rebooking</li> </ul> If the liquidity transfer is internal, this field is always filled in with 'Not applicable'.  |
| External RTGS Status Date and Time | Shows the date and time of the respective RTGS status.<br>Displayed format is: YYYY-MM-DD hh:mm:ss   |
| Status History Information         |  |
| Date and Time                      | Shows the date and time when the status was stored.<br>Displayed format is: YYYY-MM-DD hh:mm:ss  |
| Status Type                        | Shows all status types in a chronological order from the possible values: <ul style="list-style-type: none"> <li><input type="checkbox"/> Settlement Status</li> <li><input type="checkbox"/> RTGS Status</li> <li><input type="checkbox"/> Approval Status</li> </ul> Each row represents one status.   |
| Status Value                       | Shows for each status type all status values in a chronological order.<br>If the status type is set to 'SETT' for internal and outbound liquidity transfers, this field shows the possible values: <ul style="list-style-type: none"> <li><input type="checkbox"/> Settled</li> <li><input type="checkbox"/> Partially settled</li> <li><input type="checkbox"/> Unsettled</li> <li><input type="checkbox"/> Not executed</li> </ul> If the status type is set to 'SETT' for inbound liquidity transfers, this field always shows the status 'Settled'.<br>If the status type is set to 'RTGS' for outbound liquidity transfers, this field shows the possible values: |



| General Information   |   |
|-----------------------|---|
|                       | <ul style="list-style-type: none"> <li><input type="checkbox"/> RTGS rejection</li> <li><input type="checkbox"/> RTGS confirmation</li> <li><input type="checkbox"/> Not executed</li> </ul> <p>If the status type is set to 'APPR' for internal and outbound liquidity transfers, this field shows the possible values:</p> <ul style="list-style-type: none"> <li><input type="checkbox"/> Awaiting approval</li> <li><input type="checkbox"/> Approved</li> <li><input type="checkbox"/> Revoked</li> <li><input type="checkbox"/> Rejected</li> <li><input type="checkbox"/> Not applicable</li> </ul> <p>Each row represents one status.</p> |
| User Identification   | <p>Shows the user identification of those users who changed the status type 'Approval Status', if the liquidity transfer was sent via U2A and in 4-eyes mode.</p> <p>Each row represents one status.</p>  |
| Rejection Reasons     |   |
| Date and Time         | <p>Shows the date and time of the rejection.</p> <p>Displayed format is: YYYY-MM-DD hh:mm:ss</p> <p>This field is only available if the liquidity transfer was rejected.</p>  |
| Rejection Code        | <p>Shows the rejection code in respect of the rejection.</p> <p>This field is only available if the liquidity transfer was rejected.</p>  |
| Rejection Description | <p>Shows the error description according to reference data and business rules.</p> <p>This field is only available if the liquidity transfer was rejected.</p>  |

**Buttons**

| Copy | <p>This function enables you to copy fields to create a new immediate liquidity transfer order with the same attributes.</p> <p>Next screen:</p> <ul style="list-style-type: none"> <li><input type="checkbox"/> <i>Immediate liquidity transfer order – new screen</i> [ 386]</li> </ul> |
|------|---|
| New  | <p>This function enables you to create a new immediate liquidity transfer order.</p>  |

|                           |  |
|---------------------------|--|
|                           | <p>Next screen:</p> <ul style="list-style-type: none"> <li>□ <i>Immediate liquidity transfer order – new screen</i> [ 386]</li> </ul>  |
| Related Inbound Messages  | <p>This function enables you to display the inbound messages related to the selected inbound file.</p> <p>Next screens:</p> <ul style="list-style-type: none"> <li>□ <i>Inbound messages - search/list screen</i> [ ▶ 628] (if the inbound file is linked to more than one inbound message)</li> <li>□ <i>Inbound message – details screen</i> [ ▶ 635] (if the inbound file is linked to one inbound message only)</li> </ul>     |
| Related Outbound Messages | <p>This function enables you to display the outbound messages related to the selected outbound file.</p> <p>Next screens:</p> <ul style="list-style-type: none"> <li>□ <i>Outbound messages – search/list screen</i> [ 645] (if the outbound file is linked to more than one outbound message)</li> <li>□ <i>Outbound message – details screen</i> [ 653] (if the outbound file is linked to one outbound message only)</li> </ul> |
| Revisions                 | <p>This function enables you to display the revisions of the selected immediate liquidity transfer order.</p> <p>Next screen:</p> <ul style="list-style-type: none"> <li>□ <i>Revisions/audit trail - list screen</i> [ ▶ 661]</li> </ul>  |

### 2.3.2.5 Immediate Liquidity Transfer - New Screen

#### Context of Usage

This screen contains a number of fields regarding immediate liquidity transfers. You can enter data to create a new internal or outbound liquidity transfer. Afterwards you can proceed further by clicking on the buttons below.

You can use this screen either in 2-eyes or in 4-eyes mode.

This screen is not relevant for CSD, CSD participants and external CSD users.

#### Screen Access

- Cash >> Liquidity >> Immediate Liquidity Transfers >> *Immediate liquidity transfer orders – search/list screen* >> Click on the *new* or *copy* button
- Cash >> Liquidity >> Immediate Liquidity Transfers >> *Immediate liquidity transfer orders – search/list screen* >> Click on the *search* and/or *details* button >> *Immediate liquidity transfer order – details screen* >> Click on the *new* or *copy* button

- Services >> Additional Services >> Data Changes >> **Data changes – search/list** screen >> Click on the **copy** button
- Securities >> Settlement >> Data Changes >> **Data changes – search/list** screen >> Click on the **copy** button
- Cash >> Liquidity >> Data Changes >> **Data changes – search/list** screen >> Click on the **copy** button
- Services >> Additional Services >> Data Changes >> **Data changes – search/list** screen >> Click on the **search** and/or **details** button >> **Data change – details** screen >> Click on the **copy** button
- Securities >> Settlement >> Data Changes >> **Data changes – search/list** screen >> Click on the **search** and/or **details** button >> **Data change – details** screen >> Click on the **copy** button
- Cash >> Liquidity >> Data Changes >> **Data changes – search/list** screen >> Click on the **search** and/or **details** button >> **Data change – details** screen >> Click on the **copy** button

**Privileges**

To use this screen, you need the following privilege [▶ 883]:

- Send new liquidity transfer

**References****User Instructions Part**

This screen is part of the following business scenarios:

- Create a new immediate liquidity transfer order
- Copy an immediate liquidity transfer order [▶ 671]

**Business Functionality Document**

This screen corresponds to the following business function:

- Add immediate liquidity transfer instruction (T2S.GUI.LMSE.INX.0040)

Screenshot

Illustration 81: Immediate liquidity transfer order - new screen

Field

Description

| Immediate Liquidity Transfer           |  |
|--|--|
| <b>Debit Cash Account</b>              |  |
| T2S Dedicated Cash Account Number*     | Select the T2S dedicated cash account to be debited.<br>References for error messages [ 984]:<br><input type="checkbox"/> LLCI002<br><input type="checkbox"/> LLCI006<br><input type="checkbox"/> LLCI007<br><input type="checkbox"/> LLCI008<br><input type="checkbox"/> LLCI015<br><input type="checkbox"/> LLCP001<br><br>If you only have the privilege for one T2S dedicated cash account, this field is already filled in. |
| T2S Dedicated Cash Account Owner Debit | Shows the BIC of the account owner.<br>If you have first selected the 'T2S Dedicated Cash Account Number', this field is already filled in.  |
| <b>Liquidity Transfer</b>              |  |
| User Reference*                        | Enter the identification of the immediate liquidity transfer.<br>Required format is: max. 35 characters (SWIFT-x-red)<br>References for error messages [ 984]:<br><input type="checkbox"/> LLCI007   |

| Immediate Liquidity Transfer |   |
|------------------------------|---|
|                              | <input type="checkbox"/> LLCI016<br><input type="checkbox"/> <b>LLCI017{CR-847}</b><br>This field is automatically filled with the current date and time and the first two digits of the user identification.<br>You can edit the prefilled identification and insert your specific identification.<br><b>For any non-EURO Liquidity Transfer the required format is max. 16 characters (SWIFT-x-red){CR-847}</b>   |
| Creditor BIC                 | This field can be filled for outbound Liquidity Transfers towards TIPS. The required format is BIC-11. No additional Business Validations on this field.  |
| Debtor BIC                   | This field must be filled for outbound Liquidity Transfers towards TIPS. The required format is BIC-11. No additional Business Validations on this field.   |
| Amount*                      | Enter the amount of liquidity to be transferred.<br>Required format is: max. 15 digits incl. decimal point<br>References for error messages [ 984]:<br><input type="checkbox"/> LLCI005<br><input type="checkbox"/> LLCI006<br><input type="checkbox"/> LLCI007<br><input type="checkbox"/> LLCI012<br><input type="checkbox"/> LLCI014<br><input type="checkbox"/> LLCI015<br>The currency is automatically filled in, according to the 'T2S Dedicated Cash Account Number', next to the 'Amount' field. |
| Credit Cash Account          |   |
| Outbound Liquidity Transfer  | Select if you want to enter an outbound liquidity transfer.<br>You have to select one field among 'Outbound Liquidity Transfer' and 'Internal Liquidity Transfer'.  |
| Internal Liquidity Transfer  | Select if you want to enter an internal liquidity transfer.<br>You have to select one field among 'Internal Liquidity Transfer' and 'Outbound Liquidity Transfer'.  |

| Immediate Liquidity Transfer       |   |
|------------------------------------|---|
| External Account Number*           | <p>You can choose to either enter the external RTGS account, Main Cash Account, RTGS DCA or TIPS DCA (including CB accounts) <sup>17</sup> to be credited for the outbound liquidity transfer or to select it from the suggested items in the drop-down menu.</p> <p>Required format is: max. 35 characters (SWIFT-x)</p> <p>The default value is the RTGS account which is linked to the T2S dedicated cash account for the end-of-day liquidity transfer(for a currency not open in CLM) or the linked MCA <sup>17</sup>.</p> <p>If you have selected 'Outbound Liquidity Transfer', this field is mandatory.</p> <p>If you have selected 'Internal Liquidity Transfer', this field is not available.</p> <p>References for error messages [ ▶ 984]:</p> <ul style="list-style-type: none"> <li><input type="checkbox"/> LLCI003</li> <li><input type="checkbox"/> LLCI006</li> <li><input type="checkbox"/> LLCI007</li> <li><input type="checkbox"/> LLCI008</li> <li><input type="checkbox"/> LLCI015</li> </ul> |
| T2S Dedicated Cash Account Number* | <p>You can choose to either enter the T2S dedicated cash account to be credited for the outbound liquidity transfer or to select it from the suggested items in the drop-down menu.</p> <p>If you have selected 'Internal Liquidity Transfer', this field is mandatory.</p> <p>If you have selected 'Outbound Liquidity Transfer', this field is not available.</p> <p>References for error messages [ ▶ 984]:</p> <ul style="list-style-type: none"> <li><input type="checkbox"/> LLCI003</li> <li><input type="checkbox"/> LLCI006</li> <li><input type="checkbox"/> LLCI007</li> <li><input type="checkbox"/> LLCI008</li> </ul>   |

17 Please note that the described functionality won't be available before CSLD go-live.

| Immediate Liquidity Transfer |         |
|------------------------------|---------|
| <input type="checkbox"/>     | LLCI010 |
| <input type="checkbox"/>     | LLCI015 |

**Buttons**

| Submit | <p>This function enables you to create a new immediate liquidity transfer. Upon clicking on the <i>submit</i> button you will be asked to enter your PIN for digital signature purposes (NRO). With the entry of the PIN, T2S attaches a digital signature to the instruction entered by the T2S actor.</p> <p>Next screen:</p> <ul style="list-style-type: none"> <li><input type="checkbox"/> <i>Immediate liquidity transfer order – new screen</i></li> </ul> <p>References for error messages [ ▶ 984]:</p> <ul style="list-style-type: none"> <li><input type="checkbox"/> LLCI002</li> <li><input type="checkbox"/> LLCI003</li> <li><input type="checkbox"/> LLCI005</li> <li><input type="checkbox"/> LLCI006</li> <li><input type="checkbox"/> LLCI007</li> <li><input type="checkbox"/> LLCI008</li> <li><input type="checkbox"/> LLCI009</li> <li><input type="checkbox"/> LLCI010</li> <li><input type="checkbox"/> LLCI012</li> <li><input type="checkbox"/> LLCI014</li> <li><input type="checkbox"/> LLCI015</li> <li><input type="checkbox"/> LLCI016</li> </ul> |
|--------|---|
| Reset  | <p>This function enables you to set all fields to default value and blanks out all optional fields.</p> <p>Next screen:</p> <ul style="list-style-type: none"> <li><input type="checkbox"/> <i>Immediate liquidity transfer order – new screen</i> [ 883]</li> </ul>  |
| Cancel | <p>This function enables you to cancel the process and return to the previous screen.</p> <p>Next screen:</p> <ul style="list-style-type: none"> <li><input type="checkbox"/> <i>Immediate liquidity transfer orders – search/list screen</i> [ ▶ 373]</li> </ul>   |

## 2.3.2.6 Outstanding Auto-Collateralisation Credits - Search/List Screen

### Context of Usage

This screen contains a number of search fields. By inputting the relevant data, you can search for the global and detailed outstanding auto-collateralisation credits for parties which are credit consumers, either as a payment bank obtaining credit from a central bank or as a client of a payment bank obtaining credit from its payment bank. The search results for the global outstanding auto-collateralisation credits for the selected party will be displayed on the same screen. Below this, the detailed search results for the outstanding auto-collateralisation credits per T2S dedicated cash account will be displayed in a list, which is sorted by the values of the 'T2S Dedicated Cash Account Number' column in ascending order (default setting). After selecting an entry, you can proceed further by clicking on the buttons below.

The amount of outstanding auto-collateralisation refers to the limit utilisation of an auto-collateralisation limit. Payment bank users can see the outstanding auto-collateralisation credit obtained from their central bank on their T2S dedicated cash account, while clients of a payment bank can see the outstanding auto-collateralisation credit obtained from their payment bank related to the T2S dedicated cash account of their payment bank.

During the Start of Day, when the CRDM data is being replicated in the Settlement domain, only the outstanding auto-collateralisation credits data available at the End-of-Day of the previous business day is displayed at the screen. The outstanding auto-collateralisation credits data for the new business day is available as of the end of the CRDM data replication.

During night-time, the outstanding auto-collateralisation credits can only be displayed in-between night-time settlement sequences.

### Screen Access

Cash >> Liquidity >> Outstanding Auto-Coll. Credit

### Privileges

To use this screen, you need the following privilege [[▶ 892](#)]:

Outstanding auto-collateralisation credit query

### References

#### User Instructions Part

This screen is not part of a business scenario.

#### Business Functionality Document

This screen corresponds to the following business functions:

Query outstanding auto/client collateralisation credit (T2S.GUI.LMSE.CSH.0150)

Display outstanding auto/client collateralisation credit (T2S.GUI.LMSE.CSH.0160)



Screenshot

**Search Criteria - Outstanding Auto-Coll. Credit**

Parent BIC \* [NCBKDEFF001] Party BIC \* [PMBKDEFF001]

T2S Dedicated Cash Account Number [ ] Currency [EUR]

**Outstanding Auto-Collateralisation Credit - Global**

**Credit Consumer**

Party BIC: PMBKDEFF001, Parent BIC: NCBKDEFF001, Party Short Name: PMBKDEFF001 Short Name

Currency: EUR, Total Limit: 1,361,025.00, Total Outstanding Limit: 0.00

| T2S Dedicated Cash Account Number | Cur. | Limits       |                   |
|-----------------------------------|------|--------------|-------------------|
|                                   |      | Limit Amount | Outstanding Limit |
| CSHANODEEU0001                    | EUR  | 250,025.00   | 0.00              |
| CSHANODEEU0002                    | EUR  | 0.00         | 0.00              |
| CSHANODEEU0010                    | EUR  | 100,000.00   | 0.00              |
| CSHANODEEU0013                    | EUR  | 1,000,000.00 | 0.00              |
| CSHANODEEU0017                    | EUR  | 10,000.00    | 0.00              |
| CSHANODEEU0050                    | EUR  | 0.00         | 0.00              |
| CSHANODEEURAB61a                  | EUR  | 1,000.00     | 0.00              |

Journal of Limit Utilisation

Illustration 82: Outstanding auto-collateralisation credits – search/list screen

Field Descriptions

| Outstanding Auto-collateralisation Credit – Search Criteria |  |
|---|--|
| Credit Consumer   |  |
| Party BIC*  | Select the party BIC of the credit consumer from the drop-down menu or search via the <i>magnifier</i> icon.<br>Reference for error message [ ▶ 1045]:<br><input type="checkbox"/> QMPC084   |
| Parent BIC*   | Select the parent BIC of the credit consumer from the drop-down menu or search via the <i>magnifier</i> icon.<br>If the credit consumer is a payment bank, this is the BIC of its CB.<br>If the credit consumer is a client of a payment bank, this is the BIC of its CSD.<br>Reference for error message [ ▶ 1045]:<br><input type="checkbox"/> QMPC084 |
| T2S Dedicated Cash Account Number                           | Select the number of the T2S dedicated cash account from the drop-down menu.   |

| Outstanding Auto-collateralisation Credit – Search Criteria |   |
|---|---|
|   | <p>The content of the drop-down menu depends on your access rights and privileges:</p> <ul style="list-style-type: none"> <li><input type="checkbox"/> If there is only one possible account, this field is read-only.</li> <li><input type="checkbox"/> If the credit consumer is a payment bank, possible values are its T2S dedicated cash account(s).</li> <li><input type="checkbox"/> If the credit consumer is the client of a payment bank, possible values are the T2S dedicated cash account(s) of its payment bank with which the client obtains auto-collateralisation credit.</li> </ul> <p>Required format is: max. 34 characters (SWIFT-x)</p> <p>If you leave this field blank, the privileges and access rights of the requesting party are applied.</p> <p>At least one search criterion among ‘T2S Dedicated Cash Account Number’ and ‘Currency’ must be specified.</p> <p>Reference for error message [ ▶ 1045]:</p> <ul style="list-style-type: none"> <li><input type="checkbox"/> QMPC031</li> </ul> |
| Currency  | <p>Select the currency of the outstanding auto-collateralisation credit from the drop-down menu. The default value is ‘all’.</p> <p>At least one search criterion among ‘T2S Dedicated Cash Account Number’ and ‘Currency’ must be specified. If a T2S dedicated cash account is selected, the query disregards the currency.</p>   |
| <b>Outstanding Auto-collateralisation Credit - Global</b>   |   |
| <b>Credit Consumer</b>                                      |   |
| Party BIC   | <p>Shows the BIC of the credit consumer party.</p> <p>Reference for error message [ ▶ 1045]:</p> <ul style="list-style-type: none"> <li><input type="checkbox"/> QMPC084</li> </ul>   |
| Parent BIC  | <p>Shows the parent BIC of the credit consumer party.</p> <p>Reference for error message [ ▶ 1045]:</p> <ul style="list-style-type: none"> <li><input type="checkbox"/> QMPC084</li> </ul>  |
| Party Short Name  | Shows the short name of the credit consumer party.  |
| <b>Limits</b>   |   |
| Currency  | Shows the currency of the auto-collateralisation credit.  |

| Outstanding Auto-collateralisation Credit – Search Criteria |  |
|---|--|
| Total Limit   | Shows the sum of the auto-collateralisation limits associated to the selected party and the selected T2S dedicated cash account.<br><br>Provision of '99999...99' in case oversizing occurs in the integer part. Truncation of decimals in case oversizing occurs in the decimal part.             |
| Total Outstanding Limit                                     | Shows the sum of the auto-collateralisation limit utilisations associated to the selected party and the selected T2S dedicated cash account.<br><br>Provision of '99999...99' in case oversizing occurs in the integer part. Truncation of decimals in case oversizing occurs in the decimal part. |
| Outstanding Auto-collateralisation Credit - List            |  |
| T2S Dedicated Cash Account Number                           | Shows the T2S dedicated cash account that the party can use.<br><br>Reference for error message [ ▶ 1045]:<br><input type="checkbox"/> QMPC031   |
| Currency  | Shows the currency of the T2S dedicated cash account.  |
| Limits  |  |
| Limit Amount  | Shows the auto-collateralisation limit associated to the T2S dedicated cash account.   |
| Outstanding Limit   | Shows the utilisation of the auto-collateralisation limit associated to the T2S dedicated cash account.  |

**Buttons**

| Buttons |   |
|---------|---|
| Search  | This function enables you to start a search according to the criteria entered. The results are displayed in a list on the same screen.<br><br>Next screen:<br><input type="checkbox"/> <i>Outstanding auto-collateralisation credits – search/list screen</i><br><br>References for error message [ ▶ 1045]s [ ▶ 1045]:<br><input type="checkbox"/> QMPC031<br><input type="checkbox"/> QMPC084 |
| Reset   | This function enables you to set default search criteria and blanks out all optional criteria.  |

|                              |  |
|------------------------------|--|
|                              | <p>Next screen:</p> <ul style="list-style-type: none"> <li><input type="checkbox"/> <i>Outstanding auto-collateralisation credits – search/list screen</i></li> </ul>  |
| Journal of Limit Utilisation | <p>This function enables you to display the journal of limit utilisation.</p> <p>Next screen:</p> <ul style="list-style-type: none"> <li><input type="checkbox"/> <i>Limit utilisation journal – search/list screen</i> [▶ 352]</li> </ul> |

### 2.3.2.7 Overall Liquidity - Search/List Screen

#### Context of Usage

This screen contains a number of search fields. By inputting the relevant data, you can search for the overall liquidity available for a party. The search results will be displayed in an overview list.

After selecting an entry, you can proceed further by clicking on the buttons below.

This screen is not relevant for CSD, CSD participants and external CSD user.

During the Start of Day, when the CRDM data is being replicated in the Settlement domain, only the liquidity available at the End-of-Day of the previous business day is displayed at the screen. The liquidity data for the new business day is available as of the end of the CRDM data replication.

During night-time, the overall liquidity overview and detailed lists can only be displayed in-between night-time settlement sequences.

#### Screen Access

- Cash >> Liquidity >> T2S Overall Liquidity

#### Privileges

To use this screen, you need the following privilege [▶ 892]:

- T2S overall liquidity query

#### References

##### User Instructions Part

This screen is part of the following business scenario:

- View overall liquidity [▶ 677]

##### Business Functionality Document

This screen corresponds to the following business functions:

- Query overall liquidity (T2S.GUI.LMSE.CSH.0070)
- Display overall liquidity (T2S.GUI.LMSE.CSH.0080)

Screenshot

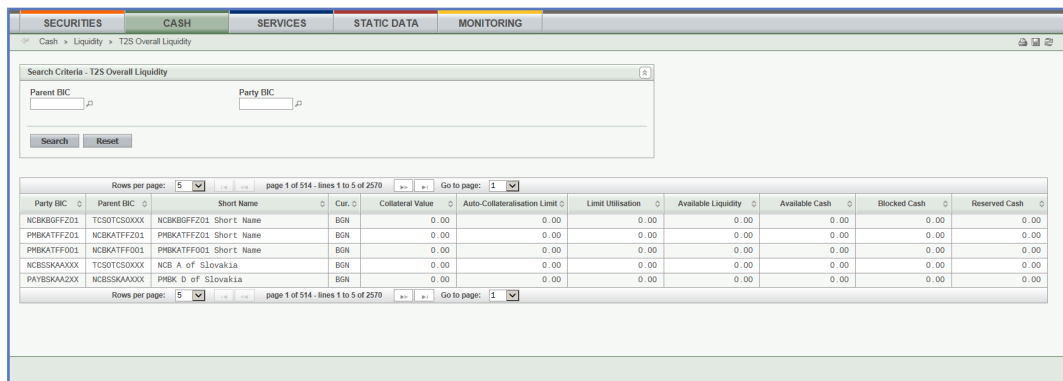

Illustration 83: Overall liquidity – search/list screen

Field Descriptions

| Overall Liquidity – Search Criteria |   |
|-------------------------------------|---|
| Parent BIC                          | <p>Select the parent BIC of the party from the drop-down menu or search via the <i>magnifier</i> icon.</p> <p>References for error messages [ ▶ 1046]:</p> <ul style="list-style-type: none"> <li><input type="checkbox"/> QMPC048</li> <li><input type="checkbox"/> QMPC084</li> </ul> <p>If there is only one possible party parent BIC for your privileges, this field is already filled in.</p> |
| Party BIC                           | <p>Select the BIC of the party from the drop-down menu or search via the <i>magnifier</i> icon.</p> <p>References for error messages [ ▶ 1046]:</p> <ul style="list-style-type: none"> <li><input type="checkbox"/> QMPC032</li> <li><input type="checkbox"/> QMPC084</li> </ul> <p>If there is only one possible party BIC for your privileges, this field is already filled in.</p>               |
| Overall Liquidity – Overview List   |   |
| Party BIC                           | <p>Shows the party BIC of the party owning the account.</p> <p>References for error messages [ ▶ 1046]:</p> <ul style="list-style-type: none"> <li><input type="checkbox"/> QMPC032</li> <li><input type="checkbox"/> QMPC084</li> </ul>  |
| Parent BIC                          | <p>Shows the parent BIC of the party owning the account.</p> <p>References for error messages [ ▶ 1046]:</p> <ul style="list-style-type: none"> <li><input type="checkbox"/> QMPC048</li> <li><input type="checkbox"/> QMPC084</li> </ul>   |
| Party Short Name                    | Shows the short name of the party owning the account.   |
| Currency                            | Shows the currency of the T2S dedicated cash account.   |

| Overall Liquidity – Search Criteria |  |
|-------------------------------------|--|
| Auto-Collateralisation Limit        | Shows the auto-collateralisation limit set by the CB.<br>Provision of '99999...99' in case oversizing occurs in the integer part. Truncation of decimals in case oversizing occurs in the decimal part.  |
| Limit Utilisation                   | Shows the utilisation of the auto-collateralisation limit.<br>Provision of '99999...99' in case oversizing occurs in the integer part. Truncation of decimals in case oversizing occurs in the decimal part.   |
| Available Liquidity                 | Shows the sum of the available liquidity.<br>The figure consists of the sum of the available cash balance, the sum of blocked cash, the sum of reserved cash plus the minimum value between: <ul style="list-style-type: none"> <li><input type="checkbox"/> The difference between the auto-collateralisation limit and the limit utilisation or</li> <li><input type="checkbox"/> The collateral value</li> </ul> Provision of '99999...99' in case oversizing occurs in the integer part. Truncation of decimals in case oversizing occurs in the decimal part. |
| Overall Liquidity – Detailed List   |  |
| Party BIC                           | Shows the party BIC of the party owning the account.<br>References for error messages [ ▶ 1046]: <ul style="list-style-type: none"> <li><input type="checkbox"/> QMPC032</li> <li><input type="checkbox"/> QMPC084</li> </ul>  |
| Parent BIC                          | Shows the parent BIC of the party owning the account.<br>References for error messages [ ▶ 1046]: <ul style="list-style-type: none"> <li><input type="checkbox"/> QMPC048</li> <li><input type="checkbox"/> QMPC084</li> </ul>   |
| Party Short Name                    | Shows the short name of the party owning the account.  |
| Currency                            | Shows the currency of the T2S dedicated cash account.  |
| Collateral Value                    | Shows the collateral value of the securities on stock in T2S, which are eligible for auto-collateralisation purposes.<br>Provision of '99999...99' in case oversizing occurs in the integer part. Truncation of decimals in case oversizing occurs in the decimal part.  |
| Available Cash                      | Shows the sum of available cash.   |

| Overall Liquidity – Search Criteria |   |
|-------------------------------------|---|
|                                     | Provision of '99999...99' in case oversizing occurs in the integer part. Truncation of decimals in case oversizing occurs in the decimal part.  |
| Blocked Cash                        | Shows the sum of blocked cash.<br><br>Provision of '99999...99' in case oversizing occurs in the integer part. Truncation of decimals in case oversizing occurs in the decimal part.  |
| Reserved Cash                       | Shows the sum of reserved cash.<br><br>Provision of '99999...99' in case oversizing occurs in the integer part. Truncation of decimals in case oversizing occurs in the decimal part. |

## Buttons

| Buttons       |  |
|---------------|--|
| Search        | <p>This function enables you to start a search according to the criteria entered. The results are displayed in an overview list on the same screen.</p> <p>Next screen:</p> <ul style="list-style-type: none"> <li><input type="checkbox"/> Overall liquidity – search/list screen</li> </ul> <p>References for error messages [ ▶ 1046]:</p> <ul style="list-style-type: none"> <li><input type="checkbox"/> QMPC032</li> <li><input type="checkbox"/> QMPC048</li> <li><input type="checkbox"/> QMPC084</li> </ul> |
| Reset         | <p>This function enables you to set default search criteria and blanks out all optional criteria.</p> <p>Next screen:</p> <ul style="list-style-type: none"> <li><input type="checkbox"/> Overall liquidity – search/list screen</li> </ul>  |
| Detailed list | <p>This function enables you to display the overall liquidity detailed list.</p> <p>Next screen:</p> <ul style="list-style-type: none"> <li><input type="checkbox"/> Overall liquidity – search/list screen</li> </ul> <p>This function is only available if the overview list is displayed.</p>   |
| Overview list | <p>This function enables you to display the overall liquidity overview list.</p> <p>Next screen:</p>   |

Overall liquidity – search/list screen

This function is only available if the detailed list is displayed.

### 2.3.2.8 Standing/Predefined Liquidity Transfer Orders - Search/List Screen

See *Standing/Predefined Liquidity Transfer Orders – Search/List Screen*.

### 2.3.2.9 Standing/Predefined Liquidity Transfer Order - Details Screen

See *Standing/Predefined Liquidity Transfer Order – Details Screen*.

### 2.3.2.10 Standing/Predefined Liquidity Transfer Order - New/Edit Screen

See *Standing/Predefined Liquidity Transfer Order – New/Edit Screen*.

### 2.3.2.11 Standing/Predefined Liquidity Transfer Order Link Sets - Search/List Screen

See *Standing/Predefined Liquidity Transfer Order Link Sets – Search/List Screen*.

### 2.3.2.12 Standing/Predefined Liquidity Transfer Order Link Set - Details Screen

See *Standing/Predefined Liquidity Transfer Order Link Set – Details Screen*.

### 2.3.2.13 Standing/Predefined Liquidity Transfer Order Link Set - New/Edit Screen

See *Standing/Predefined Liquidity Transfer Order Link Set – New/Edit Screen*.

### 2.3.2.14 Total Amount of Standing/Predefined Liquidity Transfer Orders - Search/List Screen

#### Context of Usage

This screen contains a number of search fields. By inputting the relevant data, you can search for information on the execution of standing and predefined liquidity transfer orders scheduled to be executed during the current business day. The search results will be displayed in a list, which is sorted by the values of the



'Parent BIC' column and subsequently by 'Party BIC' in ascending order (default setting). After selecting an entry, detailed information on the standing and predefined liquidity transfer orders initiated by this party will be displayed.

This screen is not relevant for CSD, external CSD and CSD participant users.

### Screen Access

- Cash >> Liquidity >> Total Stand./Predef. Liq. Transfers
- Cash >> Liquidity >> Standing/Predefined Liq. Transfers>> *Standing/predefined liquidity transfer orders – search/list screen* >> Click on the *total amount of standing/predefined liquidity transfer orders* button
- Cash >> Liquidity >> Standing/Predefined Liq. Transfers>> *Standing/predefined liquidity transfer orders – search/list screen* >> Click on the *search* and/or *details* button >> *Standing/predefined liquidity transfer order - details screen* >> Click on the *total amount of standing/predefined liquidity transfer orders* button

### Privileges

To use this screen, you need the following privilege [► 904]:

- Total amount of standing and predefined orders query

### References

#### User Instructions Part

This screen is part of the following business scenario:

- View standing/predefined liquidity transfer order details

#### Business Functionality Document

This screen corresponds to the following business functions:

- Query total amount of predefined and standing liquidity transfer order (T2S.GUI.SDSE.LTO.0070)
- Display total amount of predefined and standing liquidity transfer orders (T2S.GUI.SDSE.LTO.0080)

Total Amount of Standing/Predefined Liquidity Transfer Orders - Search/List Screen

Screenshot

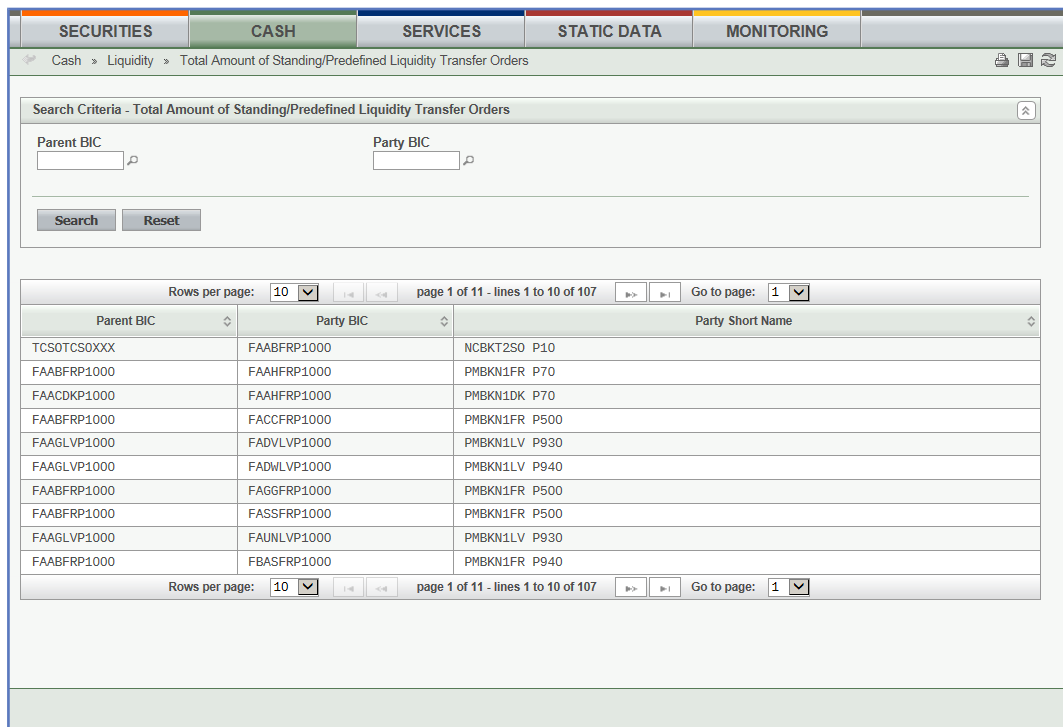

Illustration 84: Total amount of standing/predefined liquidity transfer orders - search/list screen

Field Description

| Total Amount of Standing/Predefined Liquidity Transfer Orders - Search Criteria |   |
|---|---|
| Parent BIC  | <p>Select the parent BIC of the party that initiated the standing or predefined liquidity transfer order from the drop-down menu or search via the magnifier icon.</p> <p>Required format is: max. 11 characters (SWIFT-x)</p> <p>References for error messages [ 1122]:</p> <ul style="list-style-type: none"> <li><input type="checkbox"/> QMPC048</li> <li><input type="checkbox"/> QMPC084</li> </ul> <p>If there is only one possible parent BIC for your privileges, this field is already filled in and read-only.</p> |
| Party BIC   | <p>Select the BIC of the party that initiated the standing or predefined liquidity transfer order from the drop-down menu or search via the magnifier icon.</p> <p>Required format is: max. 11 characters (SWIFT-x)</p> <p>References for error messages [ 1122]:</p> <ul style="list-style-type: none"> <li><input type="checkbox"/> QMPC032</li> <li><input type="checkbox"/> QMPC084</li> </ul> <p>If there is only one possible party BIC for your privileges, this field is already filled in and read-only.</p>         |

| Total Amount of Standing/Predefined Liquidity Transfer Orders - Search Criteria |   |
|---|---|
| Total Amount of Standing/Predefined Liquidity Transfer Orders - List            |   |
| Parent BIC  | Shows the parent BIC of the party that initiated the standing or predefined liquidity transfer order.<br>References for error messages [ ▶ 1122]:<br><input type="checkbox"/> QMPC048<br><input type="checkbox"/> QMPC084 |
| Party BIC   | Shows the BIC of the party that initiated the standing or predefined liquidity transfer order.<br>References for error messages [ ▶ 1122]:<br><input type="checkbox"/> QMPC032<br><input type="checkbox"/> QMPC084        |
| Party Short Name  | Shows the short name of the party that initiated the standing or predefined liquidity transfer order.   |
| Standing and Predefined Liquidity Transfer Orders - List                        |   |
| Currency  | Shows the currency of the standing or predefined liquidity transfer order.  |
| <b>Predefined Orders</b>  |   |
| Sum of Predefined Liquidity Transfer Orders                                     | Shows the sum of the predefined liquidity transfer orders for the current business day.   |
| Sum of Not Yet Executed Liquidity Transfer Orders                               | Shows the sum of not yet executed predefined liquidity transfer orders for the current business day.  |
| <b>Standing Orders</b>  |   |
| Sum of Standing Liquidity Transfer Orders                                       | Shows the sum of the defined standing liquidity transfer orders for the current business day.   |
| Sum of Not Yet Executed Liquidity Transfer Orders                               | Shows the sum of not yet executed standing liquidity transfer orders for the current business day.  |
| <b>Buttons</b>  |   |
| Search  | This function enables you to start a search according to the criteria entered. The results are displayed in a list on the same screen.  |

|       |   |
|-------|---|
|       | <p>If the search retrieves only one party BIC, the detailed list of standing and predefined liquidity transfers for the party is displayed directly.</p> <p>Next screen:</p> <ul style="list-style-type: none"> <li><input type="checkbox"/> <i>Total amount of standing/predefined liquidity transfer orders – search/list screen</i></li> </ul> <p>References for error messages [▶ 1122]:</p> <ul style="list-style-type: none"> <li><input type="checkbox"/> QMPC032</li> <li><input type="checkbox"/> QMPC048</li> <li><input type="checkbox"/> QMPC084</li> </ul> |
| Reset | <p>This function enables you to set default search criteria and blanks out all optional criteria.</p> <p>Next screen:</p> <ul style="list-style-type: none"> <li><input type="checkbox"/> <i>Total amount of standing/predefined liquidity transfer orders – search/list screen</i></li> </ul>  |

## 2.3.3 Settlement

### 2.3.3.1 Amendment Cash Instruction - Details Screen

**Context of Usage**

This screen displays detailed information on the selected amendment cash instruction. You can check the data and proceed further by clicking on the buttons below.

This screen is not relevant for CSD users.

**Screen Access**

Cash >> Settlement >> Maintenance Cash Instructions >> *Maintenance cash instructions – search/list screen* >> Click on the *search* and/or *details* button

**Privileges**

To use this screen, you need the following privilege [▶ 866]:

Amendment instruction for intra-balance movement audit trail list query

**References**

**User Instructions Part**

This screen is part of the following business scenario:

View amendment instruction for a settlement restriction on cash details [▶ 772]

**Business Functionality Document**

This screen corresponds to the following business function:

Display instruction details (T2S.GUI.SESE.INX.0030)

Screenshot

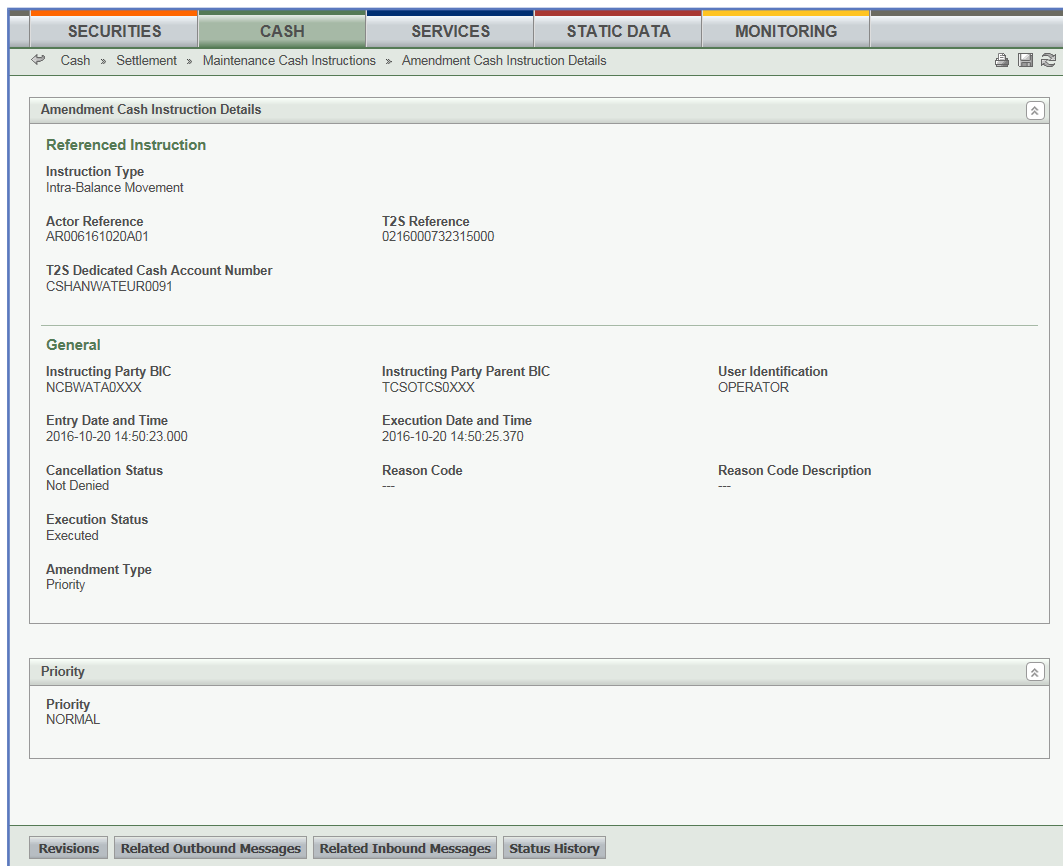

Illustration 85: Amendment cash instructions - details screen

Field Description

| Amendment Instruction             |   |
|-----------------------------------|---|
| Referenced Instruction            |   |
| Instruction Type                  | Shows the type of instruction referenced by the amendment cash instruction.<br>The only possible value is 'Intra-Balance Movement'. |
| Actor Reference                   | Shows the identification assigned by the T2S actor to the settlement restriction on cash.   |
| T2S Reference                     | Shows the identification given for a settlement restriction on cash by T2S.   |
| T2S Dedicated Cash Account Number | Shows the number of the cash account used by the settlement restriction on cash.  |
| General                           |   |
| Instructing Party BIC             | Shows the BIC of the instructing party.   |
| Instructing Party Parent BIC      | Shows the parent BIC of the instructing party.  |
| User Identification               | Shows user identification of the sending party.   |

| Amendment Instruction   |   |
|-------------------------|---|
| Entry Date and Time     | Shows the date and time when the amendment instruction has entered in T2S.<br>Displayed format is: YYYY-MM-DD hh:mm:ss:µsµsµsµsµs   |
| Execution Date and Time | Shows the date and time when the amendment instruction has been executed.<br>Displayed format is: YYYY-MM-DD hh:mm:ss:µsµsµsµsµs  |
| Cancellation Status     | Shows the cancellation status of the amendment instruction from the possible values:<br><input type="checkbox"/> DEND (for 'Denied')<br><input type="checkbox"/> NDEN: (for 'Not denied')<br>If the field 'Reason Code' is informed, the cancellation status is set to 'DEND'.          |
| Reason Code             | Shows the reason code that informs the reasoning why the amendment instruction has been denied.   |
| Reason Code Description | Shows the description of the reasoning why the amendment instruction has been denied.   |
| Execution Status        | Shows the execution status of the amendment instruction from the possible values:<br><input type="checkbox"/> EXCD (for 'Executed')<br><input type="checkbox"/> NEXD: (for 'Not executed')  |
| Amendment Type          | Shows the amendment instruction type from the possible values:<br><input type="checkbox"/> Priority<br><input type="checkbox"/> Linkages<br>If the value is set to 'Priority', the 'Priority' frame is displayed.<br>If the value is set to 'Linkages', the 'Links' frame is displayed. |
| Priority                |   |
| Priority                | Shows the value of the priority assigned by the amendment instruction from the possible values:<br><input type="checkbox"/> Normal<br><input type="checkbox"/> High<br><input type="checkbox"/> Reserved  |

| Amendment Instruction |  |
|-----------------------|--|
|                       | This frame is only available if the amendment type is set to 'Priority'.   |
| Links                 |  |
| Link                  | <p>Shows the type of the link action indicated in the amendment instruction from the possible values:</p> <ul style="list-style-type: none"><li><input type="checkbox"/> Link</li><li><input type="checkbox"/> Unlink</li></ul> <p>This frame is only available if the amendment type is set to 'Linkages'.</p>  |
| Link Type             | <p>Shows the processing position indicated in the amendment instruction from the possible values:</p> <ul style="list-style-type: none"><li><input type="checkbox"/> After</li><li><input type="checkbox"/> Before</li><li><input type="checkbox"/> With</li></ul> <p>This frame is only available if the amendment type is set to 'Linkages'.</p>   |
| Reference Type        | <p>Shows the reference type of the instruction to be linked/unlinked to from the possible values:</p> <ul style="list-style-type: none"><li><input type="checkbox"/> Account owner settlement instruction reference</li><li><input type="checkbox"/> Account owner intra balance movement reference</li><li><input type="checkbox"/> Account owner intra position movement reference</li><li><input type="checkbox"/> Account servicer reference</li><li><input type="checkbox"/> Third party reference</li><li><input type="checkbox"/> T2S reference</li></ul> <p>This frame is only available if the amendment type is set to 'Linkages'.</p> |
| Reference             | <p>Shows the identification of the instruction to be linked/unlinked to.</p> <p>This frame is only available if the amendment type is set to 'Linkages'.</p>   |
| Reference Owner       | <p>Shows the BIC of the instructing party of the instruction to be linked/unlinked to.</p> <p>This field is only filled in if the 'Reference Type' field is set to any value different than 'T2S Reference'.</p>   |

| Amendment Instruction |  |
|-----------------------|--|
|                       | This frame is only available if the amendment type is set to 'Linkages'. |

**Buttons**

| Buttons                  |  |
|--------------------------|--|
| Revisions                | <p>This function enables you to display the revisions of the selected amendment instruction.</p> <p>Next screen:</p> <ul style="list-style-type: none"> <li><input type="checkbox"/> <i>Revisions/audit trail – list</i> screen [▶ 661]</li> </ul>   |
| Related Outbound Message | <p>This function enables you to display the outbound messages related to the selected amendment instruction.</p> <p>In case the amendment instruction is linked to more than one outbound message, the <i>outbound messages - search/list</i> screen is displayed.</p> <p>In case the query returns only one valid message, the <i>outbound message – details</i> screen is displayed directly.</p> <p>Next screens:</p> <ul style="list-style-type: none"> <li><input type="checkbox"/> <i>Outbound messages – search/list</i> screen [▶ 645]</li> <li><input type="checkbox"/> <i>Outbound message – details</i> screen [▶ 653]</li> </ul> |
| Related Inbound Message  | <p>This function enables you to display the inbound messages related to the selected amendment instruction.</p> <p>In case the amendment instruction is linked to more than one inbound message, the <i>inbound messages - search/list</i> screen is displayed.</p> <p>In case the query returns only one valid message, the <i>inbound message – details</i> screen is displayed directly.</p> <p>Next screens:</p> <ul style="list-style-type: none"> <li><input type="checkbox"/> <i>Inbound messages – search/list</i> screen [▶ 628]</li> <li><input type="checkbox"/> <i>Inbound message – details</i> screen [▶ 635]</li> </ul>       |
| Status History           | <p>This function enables you to display the status history of the selected amendment instruction.</p> <p>Next screen:</p> <ul style="list-style-type: none"> <li><input type="checkbox"/> <i>Status history – details</i> screen [▶ 266]</li> </ul>  |



## 2.3.3.2 Amendment Cash Instruction - New Screen

|                         |  |
|-------------------------|--|
| <b>Context of Usage</b> | <p>This screen contains a number of fields regarding the amendment of settlement restriction on cash before its actual settlement or cancellation. You can enter new data. Afterwards you can proceed further by clicking on the buttons below.</p> <p>You can use this screen either in 2-eyes or in 4-eyes mode.</p> <p>This screen is not relevant for CSD users.</p>   |
| <b>Screen Access</b>    | <ul style="list-style-type: none"><li>□ Cash &gt;&gt; Settlement &gt;&gt; Intra-Balance Movements &gt;&gt; <i>Intra-balance movements – search/list</i> screen &gt;&gt; Click on the <i>search</i> button &gt;&gt; <i>Intra-balance movements – search/list</i> screen &gt;&gt; Click on the <i>details</i> button &gt;&gt; <i>Intra-balance movement - details</i> screen &gt;&gt; Click on the <i>amendment instruction</i> button</li></ul>   |
| <b>Privileges</b>       | <p>To use this screen you need the following privileges [▶ 867]:</p> <ul style="list-style-type: none"><li>□ Amend process indicator settlement restriction on cash on a dedicated cash account</li><li>□ Link to an instruction/pool reference belonging to a specific party</li><li>□ Send new instruction using a specific instructing party</li></ul>  |
| <b>References</b>       | <p><b>User Instructions Part</b></p> <p>This screen is part of the following business scenarios:</p> <ul style="list-style-type: none"><li>□ Add a link for a settlement restriction on cash [▶ 766]</li><li>□ Remove a link for a settlement restriction on cash [▶ 770]</li><li>□ Amend the priority for a settlement restriction on cash [▶ 768]</li></ul> <p><b>Business Functionality Document</b></p> <p>This screen corresponds to the following business function:</p> <ul style="list-style-type: none"><li>□ Amend instruction (T2S.GUI.SESE.INX.0040)</li></ul> |

Screenshot

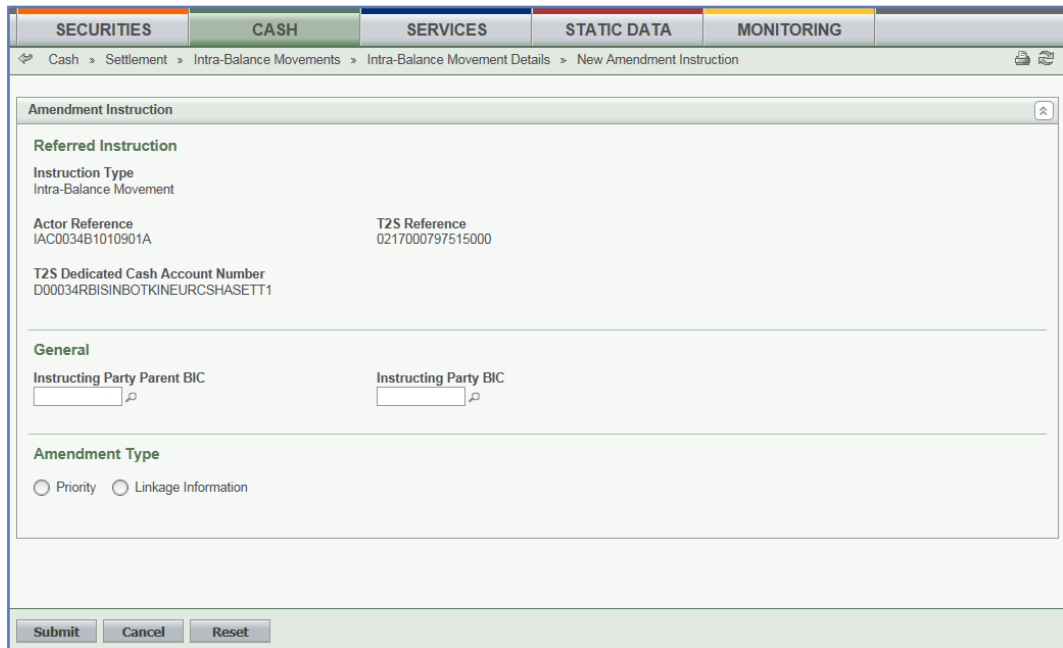

Illustration 86: Amendment cash instruction - new screen

Field Description

| Amendment Instruction             |   |
|-----------------------------------|---|
| <b>Referred Instruction</b>       |   |
| Instruction Type                  | Shows the type of the referenced instruction.<br>This field is already filled with 'Intra-Balance Movement'.  |
| Actor Reference                   | Shows the identification of the referenced instruction assigned by the T2S actor.<br>References for error messages: [▶ 927]<br><input type="checkbox"/> MVCM958<br><input type="checkbox"/> MVCP004     |
| T2S Reference                     | Shows the identification of the referenced instruction to be amended assigned by T2S.<br>References for error messages: [▶ 927]<br><input type="checkbox"/> MVCM958<br><input type="checkbox"/> MVCP004 |
| T2S Dedicated Cash Account Number | Shows the unique identification for an account.<br>This field is assigned by the account servicer using a proprietary identification scheme.  |
| <b>General</b>                    |   |
| Instructing Party Parent BIC      | Select the parent BIC of the instructing party from the drop-down menu or search via the <i>magnifier</i> icon.   |

| Amendment Instruction |  |
|-----------------------|--|
|                       | <p>If the instructing party is not filled in, the instructing party informed to the back end module is the one which the user of the GUI belongs to.</p> <p>If the instructing party is filled in, the instructing party parent BIC must also be filled in.</p> <p>Required format is: max. 11 characters (SWIFT-x)</p> <p>References for error messages: [▶ 927]</p> <ul style="list-style-type: none"> <li><input type="checkbox"/> MVDC026</li> <li><input type="checkbox"/> MVCV107</li> <li><input type="checkbox"/> MVCV232</li> <li><input type="checkbox"/> MVCP122</li> </ul>   |
| Instructing Party BIC | <p>Select the BIC of the instructing party from the drop-down menu or search via the <i>magnifier</i> icon.</p> <p>If the instructing party is not filled in, the instructing party informed to the back end module is the one which the user of the GUI belongs to.</p> <p>If the instructing party parent BIC is filled in, the instructing party BIC must also be filled in.</p> <p>Required format is: max. 11 characters (SWIFT-x)</p> <p>References for error messages: [▶ 927]</p> <ul style="list-style-type: none"> <li><input type="checkbox"/> MVCV232</li> <li><input type="checkbox"/> MVDC026</li> <li><input type="checkbox"/> MVCV107</li> <li><input type="checkbox"/> MVCP122</li> </ul> |
| Amendment Type        | <p>Select the type of the amendment instruction from the possible values:</p> <ul style="list-style-type: none"> <li><input type="checkbox"/> Priority</li> <li><input type="checkbox"/> Linkages</li> </ul> <p>Reference for error message: [▶ 927]</p> <ul style="list-style-type: none"> <li><input type="checkbox"/> MVCP034</li> </ul>  |
| Priority              |  |
| Priority              | <p>Select the level of the priority of the amendment instruction from the possible values:</p> <ul style="list-style-type: none"> <li><input type="checkbox"/> Empty (default value)</li> </ul>  |

| Amendment Instruction |   |
|-----------------------|---|
|                       | <input type="checkbox"/> Normal<br><input type="checkbox"/> High<br><input type="checkbox"/> Reserved<br><p>The default value is empty.</p> <p>Reference for error message: [▶ 927]</p> <input type="checkbox"/> MVSP211<br><p>This frame is only available if the amendment type is set to 'Priority'.</p>   |
| Linkage Information   |   |
| Link/Unlink           | <p>Select the type of the link requested from the possible values:</p> <input type="checkbox"/> Link<br><input type="checkbox"/> Unlink<br><p>Depending on the process performed, the linkage type is 'Link' or 'Unlink'.</p> <p>To add a link, select the type 'Link'. To remove a link, select the type 'Unlink'.</p> <p>This frame is only available if the amendment type is set to 'Linkage Information'.</p> <p>References for error messages: [▶ 927]</p> <input type="checkbox"/> MVCM958<br><input type="checkbox"/> MVCM960<br><input type="checkbox"/> MVLI871 |
| Link                  |   |
| Link Type             | <p>Select the processing position of the link from the possible values:</p> <input type="checkbox"/> After<br><input type="checkbox"/> Before<br><input type="checkbox"/> With<br><p>References for error messages: [▶ 927]</p> <input type="checkbox"/> MVLI809<br><input type="checkbox"/> MVLI810<br><input type="checkbox"/> MVLI811  |

| Amendment Instruction |  |
|-----------------------|--|
|                       | <ul style="list-style-type: none"> <li><input type="checkbox"/> MVL1825</li> <li><input type="checkbox"/> MVL1826</li> <li><input type="checkbox"/> MVL1827</li> <li><input type="checkbox"/> MVL1828</li> <li><input type="checkbox"/> MVL1829</li> <li><input type="checkbox"/> MVL1830</li> <li><input type="checkbox"/> MVL1837</li> <li><input type="checkbox"/> MVL1838</li> <li><input type="checkbox"/> MVL1839</li> <li><input type="checkbox"/> MVL1852</li> <li><input type="checkbox"/> MVL1855</li> <li><input type="checkbox"/> MVL1858</li> <li><input type="checkbox"/> MVL1861</li> <li><input type="checkbox"/> MVL1874</li> <li><input type="checkbox"/> MVCP042</li> </ul> <p>This frame is only available if the amendment type is set to 'Linkage Information'.</p> <p>This field is also available as a show field for existing records.</p>          |
| Reference Type        | <p>Select the reference type of the instruction to be linked/un-linked to from the possible values:</p> <ul style="list-style-type: none"> <li><input type="checkbox"/> Account Owner Settlement Instruction Reference</li> <li><input type="checkbox"/> Account Owner Intra Balance Movement Reference</li> <li><input type="checkbox"/> Account Owner Intra Position Movement Reference</li> <li><input type="checkbox"/> Account Servicer Reference</li> <li><input type="checkbox"/> Third Party reference</li> <li><input type="checkbox"/> T2S Reference</li> </ul> <p>Reference for error message: [ 927]</p> <ul style="list-style-type: none"> <li><input type="checkbox"/> MVCP099</li> </ul> <p>This frame is only available if the amendment type is set to 'Linkage Information'.</p> <p>This field is also available as a show field for existing records.</p> |

| Amendment Instruction |  |
|-----------------------|--|
| Reference             | <p>Enter the identification of the instruction to be linked/unlinked to.</p> <p>Required format is: max. 16 characters (SWIFT-x-red)</p> <p>References for error messages: [▶ 927]</p> <ul style="list-style-type: none"> <li><input type="checkbox"/> MVCM960</li> <li><input type="checkbox"/> MVCP099</li> <li><input type="checkbox"/> MVLI852</li> <li><input type="checkbox"/> MVLI855</li> <li><input type="checkbox"/> MVLI858</li> <li><input type="checkbox"/> MVLI861</li> <li><input type="checkbox"/> MVLI871</li> <li><input type="checkbox"/> MVLI874</li> </ul> <p>This frame is only available if the amendment type is set to 'Linkage Information'.</p> <p>This field is also available as a show field for existing records.</p> |
| Reference Owner       | <p>Enter the BIC of the instructing party of the instruction to be linked/unlinked to.</p> <p>Required format is: max. 11 characters (SWIFT-x)</p> <p>If the 'Reference Type' is set to 'T2S Reference' this field is not filled in.</p> <p>This frame is only available if the amendment type is set to 'Linkage Information'.</p> <p>This field is also available as a show field for existing records.</p>  |
| Options               | <p>Information on functions (icons) can be found in Common Buttons and Icons [▶ 42].</p>   |

**Buttons**

| Buttons |   |
|---------|---|
| Submit  | <p>This function enables you to create a new cash amendment instruction. Upon clicking on the <i>submit</i> button you will be asked to enter your PIN for digital signature purposes (NRO). With the entry of the PIN, T2S attaches a digital signature to the instruction entered by the T2S actor.</p> <p>Next screen:</p> |

*Intra-balance movements– search/list screen* [ ▶ 422]

References for error messages: [ ▶ 927]

MMIA002

MMIA004

MMIA006

MVCM956

MVCM958

MVCM960

MVCP004

MVCP042

MVCP099

MVCP122

MVCV107

MVCV108

MVCV232

MVDC026

MVLI809

MVLI810

MVLI811

MVLI825

MVLI826

MVLI827

MVLI828

MVLI829

MVLI830

MVLI837

MVLI838

MVLI839

MVLI852

MVLI855

MVLI858

MVLI861

|        |   |
|--------|---|
|        | <input type="checkbox"/> MVL1871<br><input type="checkbox"/> MVL1874<br><input type="checkbox"/> MVSP211  |
| Reset  | <p>This function enables you to set all fields to default value and blanks out all optional fields.</p> <p>Next screen:</p> <input type="checkbox"/> <i>Amendment cash instruction - new screen</i> |
| Cancel | <p>This function enables you to cancel the process and return to the previous screen.</p> <p>Next screen:</p> <input type="checkbox"/> <i>Intra-balance movement – details screen</i> [▶ 429]       |

### 2.3.3.3 Cancellation Cash Instruction - Details Screen

#### Context of Usage

This screen displays detailed information on the selected cancellation cash instruction. You can check the data and proceed further by clicking on the buttons below.

This screen is not relevant for CSD users.

#### Screen Access

Cash >> Settlement >> Maintenance Cash Instructions >> *Maintenance cash instructions – search/list* screen >> Click on the *search* button >> *Maintenance cash instructions – search/list* screen >> Click on the *details* button

#### Privileges

To use this screen, you need the following privilege [▶ 876]:

Cancellation instruction for intra-balance movement audit trail details query

#### References

##### User Instructions Part

This screen is part of the following business scenario:

View cancellation instruction for a settlement restriction on cash details [▶ 778]

##### Business Functionality Document

This screen corresponds to the following business function:

Display instruction details (T2S.GUI.SESE.INX.0030)



Screenshot

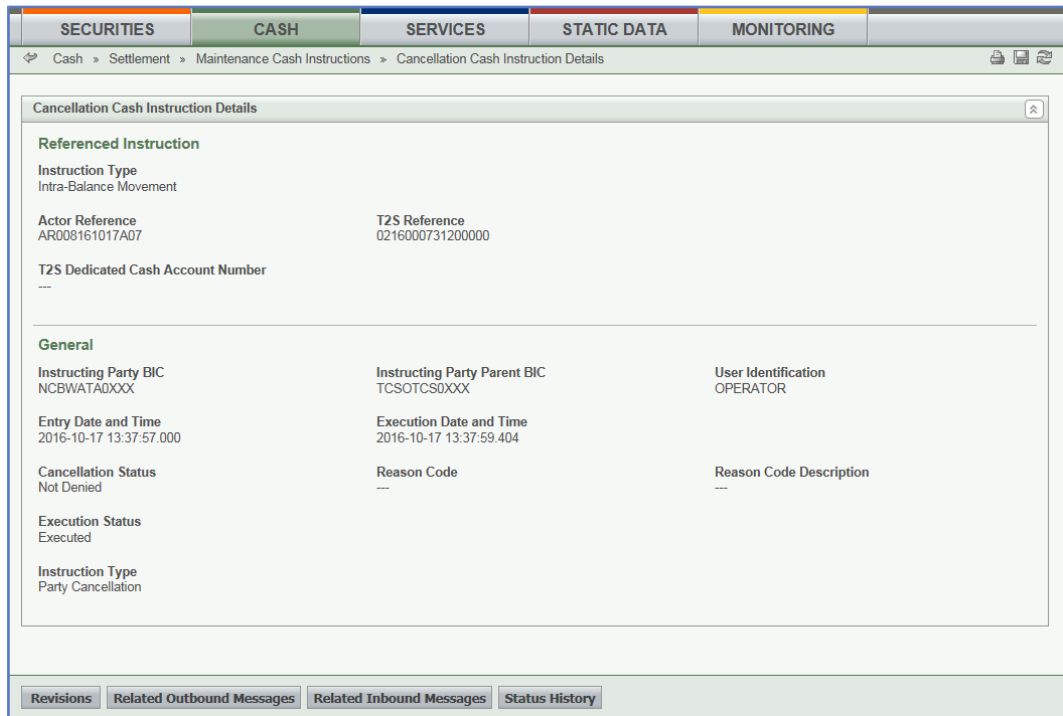

Illustration 87: Cancellation cash instruction - details screen

Field

Description

| Cancellation Instruction          |  |
|-----------------------------------|--|
| Referenced Instruction            |  |
| Instruction Type                  | Shows the type of instruction referenced by the cancellation cash instruction.<br><br>The only possible value is 'Intra-Balance Movement'. |
| Actor Reference                   | Shows the reference assigned by the T2S actor to the settlement restriction on cash.   |
| T2S Reference                     | Shows the identification of the reference assigned for a settlement restriction on cash by T2S.  |
| T2S Dedicated Cash Account Number | Shows the unique reference for the cash account used by the settlement restriction on cash.  |
| General                           |  |
| Instructing Party BIC             | Shows the BIC of the instructing party.  |
| Instructing Party Parent BIC      | Shows the parent BIC of the instructing party.   |
| User Identification               | Shows user identification of the sending party.  |
| Entry Date and Time               | Shows the date and time when the cancellation instruction has entered in T2S.<br><br>Displayed format is: YYYY-MM-DD hh:mm:ss:µsµsµsµsµs   |

| Cancellation Instruction |   |
|--------------------------|---|
| Execution Date and Time  | Shows the date and time when the cancellation instruction has been executed.<br><br>Displayed format is: YYYY-MM-DD hh:mm:ss:μsμsμsμsμs   |
| Cancellation Status      | Shows the cancellation status of the cancellation instruction from the possible values:<br><br><input type="checkbox"/> Denied<br><input type="checkbox"/> Not denied<br><br>If the 'Reason Code' field is filled in, the cancellation status is set to 'Denied'. |
| Reason Code              | Shows the reason code that informs the reasoning why the cancellation instruction has been denied.  |
| Reason Code Description  | Shows the description of the reasoning why the cancellation instruction has been denied.  |
| Execution Status         | Shows the execution status of the cancellation instruction from the possible values:<br><br><input type="checkbox"/> Executed<br><input type="checkbox"/> Not executed  |
| Instruction Type         | Shows the cancellation instruction type of the cancellation instruction.  |

**Buttons**

| Buttons                   |   |
|---------------------------|---|
| Revisions                 | This function enables you to display the revisions of the selected cancellation instruction.<br><br>Next screen:<br><br><input type="checkbox"/> <i>Revisions/audit trail – list</i> screen [▶ 661]   |
| Related Outbound Messages | This function enables you to display the outbound messages related to the cancellation instruction.<br><br>In case the cancellation instruction is linked to more than one outbound message, the <i>outbound messages - search/list</i> screen is displayed.<br><br>In case the query returns only one valid message, the <i>outbound message – details</i> screen is displayed directly.<br><br>Next screens:<br><br><input type="checkbox"/> <i>Outbound messages – search/list</i> screen [▶ 645]<br><input type="checkbox"/> <i>Outbound message – details</i> screen [▶ 653] |

|                          |  |
|--------------------------|--|
| Related Inbound Messages | <p>This function enables you to display the inbound message related to the cancellation instruction.</p> <p>In case the cancellation instruction is linked to more than one inbound message, the <i>inbound messages -search/list</i> screen is displayed.</p> <p>In case the query returns only one valid message, the <i>inbound outbound message – details</i> screen is displayed directly.</p> <p>Next screens:</p> <ul style="list-style-type: none"> <li><input type="checkbox"/> <i>Inbound messages – search/list</i> screen [▶ 628]</li> <li><input type="checkbox"/> <i>Inbound message – details</i> screen [▶ 635]</li> </ul> |
| Status History           | <p>This function enables you to display the status history of the selected cancellation instruction.</p> <p>Next screen:</p> <ul style="list-style-type: none"> <li><input type="checkbox"/> <i>Status history – details</i> screen [▶ 266]</li> </ul>   |

### 2.3.3.4 Cancellation Cash Instruction - New Screen

#### Context of Usage

This screen contains a number of fields regarding cancellation cash instructions. You can enter new data. Afterwards you can proceed further by clicking on the buttons below.

You can use this screen either in 2-eyes or in 4-eyes mode.

This screen is not relevant for CSD users.

#### Screen Access

Cash >> Settlement >> Intra-Balance Movements >> *Intra-balance movements – search/list* screen >> Click on the *search* button >> *Intra-balance movements – search/list* screen >> Click on the *details* button >> *Intra-balance movement - details* screen >> Click on the *cancellation instruction* button

#### Privileges

To use this screen you need the following privileges [▶ 877]:

- Cancel settlement restriction on cash on a dedicated cash account
- Send new instruction using a specific instructing party

#### References

##### User Instructions Part

This screen is part of the following business scenario:

- Cancel a settlement restriction on cash [▶ 777]

##### Business Functionality Document

This screen corresponds to the following business function:

Cancel instruction (T2S.GUI.SESE.INX.0050)

**Screenshot**

Illustration 88: Cancellation cash instruction - new screen

**Field**

**Description**

| Cancellation Instruction      |   |
|-------------------------------|---|
| <b>Referenced Instruction</b> |   |
| Referenced Instruction        | Shows the type of the referenced instruction. This field is already filled in with 'Intra-Balance Movement'.  |
| Actor Reference               | Shows the identification of the referenced instruction assigned by the T2S actor.   |
| T2S Reference                 | Shows the identification of the referenced instruction to be amended assigned by T2S.<br>Reference for error message [ ▶ 956]:<br><input type="checkbox"/> MVCP003  |
| T2S Dedicated Cash Account    | Shows the T2S dedicated cash account of the referenced instruction.<br>Reference for error message [ ▶ 956]:<br><input type="checkbox"/> MVCP035  |
| <b>General</b>                |   |
| Instructing Party Parent BIC  | Select the parent BIC of the instructing party from the drop-down menu or search via the <i>magnifier</i> icon.<br>In case the instructing party is not entered, the instructing party informed to the back end module will be the party you belong to. If the 'Instructing Party Parent BIC' is filled in, the 'Instructing Party BIC' has to be filled in too.<br>Required format is: max. 11 characters (SWIFT-x)<br>References for error messages [ ▶ 956]: |

| Cancellation Instruction |  |
|--------------------------|--|
|                          | <ul style="list-style-type: none"> <li><input type="checkbox"/> MVCV231</li> <li><input type="checkbox"/> MVCV108</li> <li><input type="checkbox"/> MVCP123</li> <li><input type="checkbox"/> MVDC027</li> </ul>   |
| Instructing Party BIC    | <p>Select the BIC of the instructing party from the drop-down menu or search via the <i>magnifier</i> icon.</p> <p>In case the instructing party is not entered, the instructing party informed to the back end module will be the party you belong to. If the 'Instructing Party BIC' is filled in, the 'Instructing Party Parent BIC' has to be filled in too'</p> <p>Required format is: max. 11 characters (SWIFT-x)</p> <p>References for error messages [ ▶ 956]:</p> <ul style="list-style-type: none"> <li><input type="checkbox"/> MVCV231</li> <li><input type="checkbox"/> MVCV108</li> <li><input type="checkbox"/> MVCP123</li> <li><input type="checkbox"/> MVDC027</li> </ul> |

**Buttons**

| Submit | <p>This function enables you to create a new cancellation cash instruction. Upon clicking on the <i>submit</i> button you will be asked to enter your PIN for digital signature purposes (NRO). With the entry of the PIN, T2S attaches a digital signature to the instruction entered by the T2S actor.</p> <p>Next screen:</p> <ul style="list-style-type: none"> <li><input type="checkbox"/> <i>Intra-balance movements with current and historical status – search</i> screen [ ▶ 422]</li> </ul> <p>References for error messages [ ▶ 956]:</p> <ul style="list-style-type: none"> <li><input type="checkbox"/> MVDC027</li> <li><input type="checkbox"/> MMCR201</li> <li><input type="checkbox"/> MMCR202</li> <li><input type="checkbox"/> MVCP003</li> <li><input type="checkbox"/> MVCP035</li> <li><input type="checkbox"/> MVCP123</li> <li><input type="checkbox"/> MVCV108</li> <li><input type="checkbox"/> MVCV231</li> </ul> |
|--------|--|

|        |  |
|--------|--|
| Cancel | This function enables you to cancel the process and return to the previous screen.<br>Next screen:<br><input type="checkbox"/> <i>Intra-balance movement - details</i> screen [▶ 429]            |
| Reset  | This function enables you to set all fields to default value and blanks out all optional criteria.<br>Next screen:<br><input type="checkbox"/> <i>Cancellation cash instruction - new</i> screen |

### 2.3.3.5 Intra-Balance Movements - Search/List Screen

#### Context of Usage

This screen contains a number of search fields. By inputting the relevant data, you can search for settlement restrictions on cash. The search results will be displayed in a list. After selecting an entry, you can proceed further by clicking on the buttons below.

When exporting the content of this screen, you receive the list and the corresponding details for each data record.

This screen is not relevant for CSD users.

#### Screen Access

Cash >> Settlement >> Intra-Balance Movements >> *Intra-balance movements– search/list* screen

#### Privileges

To use this screen, you need the following privilege [▶ 886]:

Intra-balance movements query

#### References

##### User Instructions Part

This screen is part of the following business scenarios:

- Add a link for a settlement restriction on cash [▶ 766]
- Amend the priority for a settlement restriction on cash [▶ 768]
- Copy a settlement restriction on cash [▶ 753]
- Cancel a settlement restriction on cash [▶ 777]
- Enter a settlement restriction on cash [▶ 751]
- Remove a link for a settlement restriction on cash [▶ 770]
- View settlement restriction on cash details [▶ 756]

##### Business Functionality Document

This screen corresponds to the following business function:

- Display instruction list (T2S.GUI.SESE.INX.0020)

Screenshot

Illustration 89: Intra-balance movements - search/list screen

Field

Description

| Intra-Balance Movements – Search Criteria |  |
|---|--|
| General Criteria                          |  |
| Actor Reference                           | Enter the identification assigned by the T2S actor.<br>Required format is: max. 16 characters (SWIFT-x)                                |
| T2S Reference                             | Enter the identification of the settlement restriction assigned by T2S.<br>Required format is: max. 16 characters (SWIFT-x)            |
| Account Owner Reference                   | Enter the identification of the settlement restriction assigned by the T2S party.<br>Required format is: max. 16 characters (SWIFT-x)  |
| T2S Dedicated Cash Account Number         | Select the T2S dedicated cash account.<br>Required format is: max. 34 characters (SWIFT-x)<br>References for error messages [ ▶ 1012]: |

| Intra-Balance Movements – Search Criteria |  |
|---|--|
|   | <input type="checkbox"/> QMPC031<br><input type="checkbox"/> QMPC072   |
| Currency                                  | <p>Select the currency from the drop-down menu. The default value is 'all'.</p> <p>Reference for error message [ ▶ 1012]:</p> <input type="checkbox"/> QMPC072   |
| Account Servicer Reference                | <p>Enter the reference of the settlement restriction assigned by the CB.</p> <p>Required format is: max. 16 characters (SWIFT-x)</p>   |
| Third Party Reference                     | <p>Enter the reference of the settlement restriction assigned by a third party.</p> <p>Required format is: max. 16 characters (SWIFT-x)</p>  |
| Instructing Party Parent BIC              | <p>Select the parent BIC of the instructing party from the drop-down menu or search via the magnifier icon.</p> <p>Required format is: max. 11 characters (SWIFT-x)</p> <p>References for error messages [ ▶ 1012]:</p> <input type="checkbox"/> QMPC048<br><input type="checkbox"/> QMPC084 |
| Instructing Party BIC                     | <p>Select the BIC of the instructing party from the drop-down menu or search via the magnifier icon.</p> <p>Required format is: max. 11 characters (SWIFT-x)</p> <p>References for error messages [ ▶ 1012]:</p> <input type="checkbox"/> QMPC032<br><input type="checkbox"/> QMPC084        |
| T2S Dedicated Cash Account Owner          | <p>You can choose to either enter the 'T2S Dedicated Cash Account Owner' or to select it from the suggested items in the drop-down menu.</p> <p>References for error messages [ ▶ 1012]:</p> <input type="checkbox"/> QMPC032<br><input type="checkbox"/> QMPC072                            |
| Restriction Reference                     | <p>Enter the unique identification of the restricted cash balance.</p> <p>Required format is: max. 16 characters (SWIFT-x)</p>   |



| Intra-Balance Movements – Search Criteria |   |
|---|---|
|   | Upon the settlement of the restriction, the 'Restriction Reference' is updated.   |
| Restriction Type - Balance From           | <p>You can choose to either enter the 'Restriction Type - Balance From' or to select it from the suggested items in the drop-down menu.</p> <p>The restriction type code is assigned by the CB.</p> <p>The default value is 'All'.</p> <p>All the possible values stored in SD and that are available according to the privileges will be shown</p> <p>Reference for error message [ ▶ 1012]:</p> <ul style="list-style-type: none"> <li><input type="checkbox"/> IIMP079</li> </ul> <p>The cash balance type of 'Balance from' must be different from the cash balance type of 'Balance to'.</p> |
| Restriction Type - Balance To             | <p>You can choose to either enter the 'Restriction Type - Balance To' or to select it from the suggested items in the drop-down menu.</p> <p>The restriction type code is assigned by the CB.</p> <p>The default value is 'All'.</p> <p>All the possible values stored in SD and that are available according to the privileges will be shown</p> <p>Reference for error message [ ▶ 1012]:</p> <ul style="list-style-type: none"> <li><input type="checkbox"/> IIMP079</li> </ul> <p>The cash balance type of 'Balance from' must be different from the cash balance type of 'Balance to'.</p>   |
| Range Criteria                            |   |
| Intended Settlement Date - from           | <p>Enter the date from which the instruction is eligible for settlement or use the <i>calendar</i> icon.</p> <p>Required format is: YYYY-MM-DD</p> <p>Reference for error message [ ▶ 1012]:</p> <ul style="list-style-type: none"> <li><input type="checkbox"/> QMPC012</li> </ul>   |
| Intended Settlement Date - to             | <p>Enter the date until which the instruction is eligible for settlement or use the <i>calendar</i> icon.</p> <p>Required format is: YYYY-MM-DD</p> <p>Reference for error message [ ▶ 1012]:</p>   |

| Intra-Balance Movements – Search Criteria |   |
|---|---|
|   | <input type="checkbox"/> QMPC012  |
| Actual Settlement Date - from             | <p>Enter the date and time from which the latest settlement occurred or use the <i>calendar</i> icon.</p> <p>Required format is: YYYY-MM-DD hh:mm:ss</p> <p>References for error messages [ ▶ 1012]:</p> <input type="checkbox"/> QMPC013<br><input type="checkbox"/> QMPC014     |
| Actual Settlement Date - to               | <p>Enter the date and time until which the latest settlement occurred or use the <i>calendar</i> icon.</p> <p>Required format is: YYYY-MM-DD hh:mm:ss</p> <p>Reference for error message [ ▶ 1012]:</p> <input type="checkbox"/> QMPC014  |
| Entry Date and Time - from                | <p>Enter the lower bound of the search range for the entry date and time or use the <i>calendar</i> icon.</p> <p>Required format is: YYYY-MM-DD hh:mm:ss</p> <p>References for error messages [ ▶ 1012]:</p> <input type="checkbox"/> QMPC015<br><input type="checkbox"/> QMPC073 |
| Entry Date and Time - to                  | <p>Enter the upper bound of the search range for the entry date and time or use the <i>calendar</i> icon.</p> <p>Required format is: YYYY-MM-DD hh:mm:ss</p> <p>References for error messages [ ▶ 1012]:</p> <input type="checkbox"/> QMPC015<br><input type="checkbox"/> QMPC095 |
| Amount more/equal than                    | <p>Enter the lower bound of the search range for the amount.</p> <p>Required format is: max. 18 characters (thereof max. 5 decimal places and decimal point)</p> <p>Reference for error message [ ▶ 1012]:</p> <input type="checkbox"/> QMPC005                                   |
| Amount less/equal than                    | <p>Enter the upper bound of the search range for the amount.</p> <p>Required format is: max. 18 characters (thereof max. 5 decimal places and decimal point)</p> <p>Reference for error message [ ▶ 1012]:</p>  |

| Intra-Balance Movements – Search Criteria |  |
|---|--|
|   | <input type="checkbox"/> QMPC005   |
| Status Criteria                           |  |
| Settlement Status                         | <p>Select the settlement status of the settlement restriction from the possible values:</p> <ul style="list-style-type: none"> <li><input type="checkbox"/> All (default value)</li> <li><input type="checkbox"/> Partially settled</li> <li><input type="checkbox"/> Settled</li> <li><input type="checkbox"/> Unsettled</li> </ul>   |
| ISO Settlement status                     | <p>Select the settlement status of the settlement restriction from the possible values:</p> <ul style="list-style-type: none"> <li><input type="checkbox"/> All (default value)</li> <li><input type="checkbox"/> Pending</li> <li><input type="checkbox"/> Failing</li> </ul> <p>If value 'Settlement Status' field is set to 'Settled' or 'Cancellation Status' field is set to 'Cancelled', this field is disabled.</p> |
| Cancellation Status                       | <p>Select the cancellation status of the settlement restriction from the possible values:</p> <ul style="list-style-type: none"> <li><input type="checkbox"/> All (default value)</li> <li><input type="checkbox"/> Cancelled</li> <li><input type="checkbox"/> Not cancelled</li> </ul>   |
| Intra-Balance Movements - List            |  |
| Actor Reference                           | Shows the identification of the settlement restriction assigned by the T2S Actor.  |
| Instructing Party BIC                     | Shows the BIC of the instructing party.  |
| Instructing Party Parent BIC              | Shows the parent BIC of the instructing party.   |
| Dedicated Cash Account                    | Shows the T2S dedicated cash account.  |
| Amount                                    | Shows the original amount stated in the settlement restriction.  |
| Restriction Type - Balance From           | Shows the code specified by the CB to identify the restriction.  |
| Restriction Type - Balance To             | Shows the code specified by the CB to identify the restriction.  |

| Intra-Balance Movements – Search Criteria |   |
|---|---|
| Restriction Reference                     | Shows the unique identification of a restricted position.<br>Upon the settlement of the restriction, the 'Restriction Reference' is updated.  |
| Settlement Status                         | Shows the current settlement status of the settlement restriction from the possible values:<br><input type="checkbox"/> Unsettled<br><input type="checkbox"/> Settled<br><input type="checkbox"/> Partially settled |
| Cancellation Status                       | Shows the current cancellation status of the settlement restriction from the possible values:<br><input type="checkbox"/> Cancelled<br><input type="checkbox"/> Not cancelled                                       |

## Buttons

|        |  |
|--------|--|
| Search | <p>This function enables you to start a search according to the criteria entered. The results are displayed in a list on the next screen.</p> <p>If the search retrieves a single record, the <i>details</i> screen is displayed directly.</p> <p>Next screens:</p> <ul style="list-style-type: none"><li><input type="checkbox"/> <i>Intra-balance movements – search/list</i> screen</li><li><input type="checkbox"/> <i>Intra-balance movement – details</i> screen [<a href="#">▶ 429</a>]</li></ul> <p>References for error messages [<a href="#">▶ 1012</a>]:</p> <ul style="list-style-type: none"><li><input type="checkbox"/> QMPC005</li><li><input type="checkbox"/> QMPC012</li><li><input type="checkbox"/> QMPC013</li><li><input type="checkbox"/> QMPC014</li><li><input type="checkbox"/> QMPC015</li><li><input type="checkbox"/> QMPC031</li><li><input type="checkbox"/> QMPC032</li><li><input type="checkbox"/> QMPC048</li><li><input type="checkbox"/> QMPC072</li><li><input type="checkbox"/> QMPC073</li><li><input type="checkbox"/> QMPC084</li></ul> |
|--------|--|

| Intra-Balance Movement - Details Screen |  |
|---|--|
|   | <input type="checkbox"/> QMPC095   |
| Reset                                   | This function enables you to set default search criteria and blanks out all optional criteria.<br>Next screen:<br><input type="checkbox"/> <i>Intra-balance movements– search/list</i> screen        |
| New                                     | This function enables you to create a new settlement restriction on cash.<br>Next screen:<br><input type="checkbox"/> <i>Intra-balance movement – new</i> screen [ ▶ 436]                            |
| Details                                 | This function enables you to display the details of the selected settlement restriction on cash.<br>Next screen:<br><input type="checkbox"/> <i>Intra-balance movement – details</i> screen [ ▶ 429] |

### 2.3.3.6 Intra-Balance Movement - Details Screen

#### Context of Usage

This screen displays detailed information on the selected settlement restriction on cash. You can check the data and proceed further by clicking on the buttons below.

This screen is not relevant for CSD users.

#### Screen Access

Cash >> Settlement >> Intra-Balance Movements >> *Intra-balance movements– search/list* screen >> Click on the *search* button >> *Intra-balance movements – search/list* screen >> Click on the *details* button

#### Privileges

To use this screen, you need the following privilege [ ▶ 885]:

Intra balance movement audit trail list query

#### References

##### User Instructions Part

This screen is part of the following business scenarios:

- Add a link for a settlement restriction on cash [ ▶ 766]
- Amend the priority for a settlement restriction on cash [ ▶ 768]
- Copy a settlement restriction on cash [ ▶ 753]
- Cancel a settlement restriction on cash [ ▶ 777]
- Remove a link for a settlement restriction on cash [ ▶ 770]
- View settlement restriction on cash details [ ▶ 756]

##### Business Functionality Document

This screen corresponds to the following business function:

Display instruction details (T2S.GUI.SESE.INX.0030)

**Screenshot**

Illustration 90: Intra-balance movement - details screen

**Field**

**Description**

| Intra-Balance Movement                     |   |
|--|---|
| T2S Dedicated Cash Account Owner Reference | Shows the identification of the settlement restriction assigned by the instructing party.<br>Only one field among 'T2S Dedicated Cash Account Owner Reference', 'Account Servicer Reference' or 'Third Party Reference' is filled in. |
| Account Servicer Reference                 | Shows the identification of the settlement restriction assigned by the CB.  |

| Intra-Balance Movement               |   |
|--------------------------------------|---|
|                                      | Only one field among 'T2S Dedicated Cash Account Owner Reference', 'Account Servicer Reference' or 'Third Party Reference' is filled in.  |
| Third Party Reference                | Shows the identification of the settlement restriction assigned by a third party.<br><br>Only one field among 'T2S Dedicated Cash Account Owner Reference', 'Account Servicer Reference' or 'Third Party Reference' is filled in. |
| Reference                            | Shows the identification of the settlement restriction assigned by T2S.   |
| Instructing Party BIC                | Shows the BIC of the instructing party.   |
| Instructing Party Parent BIC         | Shows the parent BIC of the instructing party.  |
| User Identification                  | Shows the user identification of the sending party.   |
| Entry Date and Time                  | Shows the timestamp when the instruction is entered in T2S.<br><br>Displayed format is: YYYY-MM-DD hh:mm:ss:µsµsµsµsµs  |
| Intended Settlement Date             | Shows the date when the instruction is eligible for settlement.<br><br>Displayed format is: YYYY-MM-DD  |
| Final Settlement Date and Time       | Shows the business date and the calendar time when the settlement restriction is settled totally.<br><br>Displayed format is: YYYY-MM-DD hh:mm:ss:µsµsµsµsµs  |
| Actual Settlement Date and Time      | Shows the business date and the calendar time when the last settlement occurred (partially or totally).<br><br>Displayed format is: YYYY-MM-DD hh:mm:ss:µsµsµsµsµs  |
| Priority                             | Shows the priority of the settlement restriction from the possible values:<br><br><input type="checkbox"/> Normal<br><input type="checkbox"/> High<br><input type="checkbox"/> Reserved   |
| <b>Balance and Cash Details</b>      |   |
| T2S Dedicated Cash Account Owner BIC | Shows the BIC of the owner of the securities account.   |

| Intra-Balance Movement            |  |
|-----------------------------------|--|
| T2S Dedicated Cash Account Number | Shows the T2S dedicated cash account used in the settlement restriction.   |
| Original Settlement Amount        | Shows the original amount stated in the settlement restriction.  |
| Settled Settlement Amount         | Shows the settled amount of the settlement restriction.  |
| Balance from                      |  |
| Restriction Type                  | Shows the code defined in reference data to identify the restriction from which the cash have to be restricted/unrestricted.   |
| Restriction Processing Type       | Shows the type of processing T2S shall apply for the restriction from the possible values: <ul style="list-style-type: none"> <li><input type="checkbox"/> Rejection</li> <li><input type="checkbox"/> Reservation</li> <li><input type="checkbox"/> Blocking</li> <li><input type="checkbox"/> Earmarking for auto-collateralisation</li> <li><input type="checkbox"/> Deliverable</li> <li><input type="checkbox"/> CoSD blocking</li> </ul> |
| Balance to                        |  |
| Restriction Type                  | Shows the code defined in reference data to identify the restriction to which the cash have to be restricted/unrestricted.   |
| Restriction Processing Type       | Shows the type of processing T2S shall apply for the restriction from the possible values: <ul style="list-style-type: none"> <li><input type="checkbox"/> Rejection</li> <li><input type="checkbox"/> Reservation</li> <li><input type="checkbox"/> Blocking</li> <li><input type="checkbox"/> Earmarking for auto-collateralisation</li> <li><input type="checkbox"/> Deliverable</li> <li><input type="checkbox"/> CoSD blocking</li> </ul> |
| Restriction Reference             | Shows the unique identification of the restricted cash balance.<br><br>Upon the settlement of the restriction, the 'Restriction Reference' is updated.   |
| Status Information                |  |



| Intra-Balance Movement |   |
|------------------------|---|
| Status Information     |   |
| Cancellation Status    | Shows the current cancellation status of the settlement restriction from the possible values: <ul style="list-style-type: none"><li><input type="checkbox"/> Cancelled</li><li><input type="checkbox"/> Not cancelled</li></ul>   |
| Settlement Status      | Shows the current settlement status of the settlement restriction from the possible values: <ul style="list-style-type: none"><li><input type="checkbox"/> Settled</li><li><input type="checkbox"/> Unsettled</li><li><input type="checkbox"/> Partially settled</li></ul>  |
| ISO Settlement Status  | Shows the current ISO settlement status of the settlement restriction from the possible values: <ul style="list-style-type: none"><li><input type="checkbox"/> Pending</li><li><input type="checkbox"/> Failing</li></ul>   |
| Link                   |   |
| Link Type              | Shows the type of link of the instruction, the restriction is linked with from the possible values: <ul style="list-style-type: none"><li><input type="checkbox"/> After</li><li><input type="checkbox"/> Before</li><li><input type="checkbox"/> With</li><li><input type="checkbox"/> Info</li></ul>  |
| Reference Type         | Shows the reference type of the instruction to be linked/unlinked to from the possible values: <ul style="list-style-type: none"><li><input type="checkbox"/> Account Owner Settlement Instruction Reference</li><li><input type="checkbox"/> Account Owner Settlement Instruction Reference</li><li><input type="checkbox"/> Account Owner Intra Balance Movement Reference</li><li><input type="checkbox"/> Account Owner Intra Position Movement Reference</li><li><input type="checkbox"/> Account Servicer Reference</li><li><input type="checkbox"/> Third Party reference</li><li><input type="checkbox"/> T2S reference</li></ul> |
| Reference              | Shows the identification of the instruction to be linked/unlinked to.   |
| Reference Owner        | Shows the BIC of the instructing party of the instruction to be linked/unlinked to.   |

| Intra-Balance Movement     |  |
|----------------------------|--|
|                            | This field is only filled in if the 'Reference Type' is set to any value different than 'T2S reference'. |
| Pool Instruction Reference | Shows the collective reference identifying a set of messages.  |
| Pool Instruction Counter   | Shows the maximum number of instructions included in the pool.   |
| Pool Reference Owner BIC   | Shows the BIC of the owner of the Pool Instruction Reference   |

## Buttons

| Amendment Instruction     | <p>This function enables you to create a new amendment instruction for the selected settlement restriction on cash.</p> <p>This button is not available in case any status of the settlement restriction on cash does not allow the creation of the amendment instruction.</p> <p>Next screen:</p> <ul style="list-style-type: none"> <li><input type="checkbox"/> <i>Amendment cash instruction - new screen</i> [ ▶ 409]</li> </ul>          |
|---------------------------|--|
| Cancellation Instruction  | <p>This function enables you to create a new cancellation instruction for the selected settlement restriction on cash.</p> <p>This button is not available in case any status of the settlement restriction on cash does not allow the creation of the cancellation instruction.</p> <p>Next screen:</p> <ul style="list-style-type: none"> <li><input type="checkbox"/> <i>Cancellation cash instruction - new screen</i> [ ▶ 419]</li> </ul> |
| Revisions                 | <p>This function enables you to display the revisions of the selected settlement restriction on cash.</p> <p>Next screen:</p> <ul style="list-style-type: none"> <li><input type="checkbox"/> <i>Revisions/audit trail – details screen</i> [ ▶ 661]</li> </ul>  |
| Related Outbound Messages | <p>This function enables you to display the outbound messages related to the selected settlement restriction on cash.</p> <p>Next screens:</p> <ul style="list-style-type: none"> <li><input type="checkbox"/> <i>Outbound messages – search/list screen</i> [ ▶ 645] (if the settlement restriction on cash is linked to more than one outbound message)</li> </ul>   |

|                          |  |
|--------------------------|--|
|                          | <ul style="list-style-type: none"><li>□ <i>Outbound message – details</i> screen [ ▶ 653] (if the settlement restriction on cash is linked to one outbound message only)</li></ul>   |
| Related Inbound Messages | <p>This function enables you to display the inbound message related to the selected settlement restriction on cash.</p> <p>Next screens:</p> <ul style="list-style-type: none"><li>□ <i>Inbound messages – search/list</i> screen [ ▶ 628] (if the settlement restriction on cash is linked to more than one inbound message)</li><li>□ <i>Inbound message – details</i> screen [ ▶ 635] (if the settlement restriction on cash is linked to one inbound message only)</li></ul> |
| Copy Instruction         | <p>This function enables you to copy fields to create a new settlement restriction on cash with the same attributes.</p> <p>Next screen:</p> <ul style="list-style-type: none"><li>□ <i>Intra-balance movement – new</i> screen [ ▶ 436]</li></ul>   |
| Status History           | <p>This function enables you to display the status history of the selected settlement restriction on cash.</p> <p>Next screen:</p> <ul style="list-style-type: none"><li>□ <i>Status history – details</i> screen [ ▶ 266]</li></ul>   |
| Cash Balance Details     | <p>This function enables you to display the cash balance details related to the selected settlement restriction on cash.</p> <p>Next screen:</p> <ul style="list-style-type: none"><li>□ <i>T2S DCA balance - details</i> screen [ ▶ 361]</li></ul>  |
| Links                    | <p>This function enables you to display all the links data preventing settlement at the moment when the request is performed.</p> <p>This button is not available in the following cases:</p> <ul style="list-style-type: none"><li>□ Cancellation Status = “cancelled”</li><li>□ Settlement Status = “settled”</li></ul> <p>Next screen:</p> <ul style="list-style-type: none"><li>□ <i>Links Preventing Settlement -</i> screen [ ▶ 276]</li></ul>                             |

### 2.3.3.7 Intra-Balance Movement - New Screen

|                         |  |
|-------------------------|--|
| <b>Context of Usage</b> | <p>This screen contains a number of fields regarding settlement restrictions on cash (intra-balance movements). You can enter new data. Afterwards you can proceed further by clicking on the buttons below.</p> <p>You can use this screen either in 2-eyes or in 4-eyes mode.</p> <p>This screen is not relevant for CSD users.</p>  |
| <b>Screen Access</b>    | <ul style="list-style-type: none"><li><input type="checkbox"/> Cash &gt;&gt; Settlement &gt;&gt; Intra-Balance Movements &gt;&gt; <i>Intra-balance movements with current and historical status – search</i> screen &gt;&gt; Click on the <i>new</i> button</li><li><input type="checkbox"/> Cash &gt;&gt; Settlement &gt;&gt; Intra-Balance Movements &gt;&gt; <i>Intra-balance movements with current and historical status – search</i> screen &gt;&gt; Click on the <i>search</i> button &gt;&gt; <i>Intra-balance movements – list</i> screen &gt;&gt; Click on the <i>details</i> button &gt;&gt; <i>Intra-balance movement – details</i> screen &gt;&gt; Click on the <i>copy</i> button</li><li><input type="checkbox"/> Cash &gt;&gt; Cash Account &gt;&gt; Cash Account Balances &gt;&gt; <i>T2S DCA balances – search/list</i> screen &gt;&gt; Click on the <i>create intra balance movement</i> button</li></ul> |
| <b>Privileges</b>       | <p>To use this screen, you need the following privileges [▶ 886]:</p> <ul style="list-style-type: none"><li><input type="checkbox"/> Send new settlement restriction on cash on a dedicated cash account</li><li><input type="checkbox"/> Link to an instruction/pool reference belonging to a specific party</li><li><input type="checkbox"/> Unblock CoSD cash blocking related to cancelled CoSD settlement instructions on behalf of the relevant CSD in T2S</li><li><input type="checkbox"/> Send new instruction using a specific instructing party</li></ul>  |
| <b>References</b>       | <p><b>User Instructions Part</b></p> <p>This screen is part of the following business scenarios:</p> <ul style="list-style-type: none"><li><input type="checkbox"/> Enter a settlement restriction on cash [▶ 751]</li><li><input type="checkbox"/> Copy a settlement restriction on cash [▶ 753]</li></ul> <p><b>Business Functionality Document</b></p> <p>This screen corresponds to the following business function:</p> <ul style="list-style-type: none"><li><input type="checkbox"/> Add settlement instruction or settlement restriction (T2S.GUI.SESE.INX.0070)</li></ul>   |

Screenshot

Illustration 91: Intra-balance movement - new screen

Field Description

| Intra-Balance Movement       |  |
|------------------------------|--|
| Actor Reference*             | Enter the identification of the T2S actor.<br>Required format is: max. 16 characters (SWIFT-x-red)<br>References for error messages [ ▶ 994]: <ul style="list-style-type: none"> <li><input type="checkbox"/> MVDC003</li> <li><input type="checkbox"/> MVDC005</li> <li><input type="checkbox"/> MVDC007</li> <li><input type="checkbox"/> MVDC015</li> <li><input type="checkbox"/> MVDC017</li> <li><input type="checkbox"/> MVDC019</li> <li><input type="checkbox"/> MVDC022</li> <li><input type="checkbox"/> MVDC023</li> <li><input type="checkbox"/> MVS705</li> <li><input type="checkbox"/> MVS708</li> </ul> |
| Instructing Party Parent BIC | Select the parent BIC of the instructing party from the drop-down menu or search via the <i>magnifier</i> icon.  |

| Intra-Balance Movement |   |
|------------------------|---|
|                        | <p>Required format is: max. 11 characters (SWIFT-x)</p> <p>References for error messages [ ▶ 994]:</p> <ul style="list-style-type: none"><li><input type="checkbox"/> MVCV110</li><li><input type="checkbox"/> MVCV230</li><li><input type="checkbox"/> MVDC025</li><li><input type="checkbox"/> MVCP120</li><li><input type="checkbox"/> MVCV291</li><li><input type="checkbox"/> MVDC003</li><li><input type="checkbox"/> MVDC005</li><li><input type="checkbox"/> MVDC007</li><li><input type="checkbox"/> MVDC015</li><li><input type="checkbox"/> MVDC017</li><li><input type="checkbox"/> MVDC019</li><li><input type="checkbox"/> MVDC022</li><li><input type="checkbox"/> MVDC023</li><li><input type="checkbox"/> MVLI868</li></ul> <p>In case the instructing party is not entered, the instructing party informed to the back end module will be the party you belong to. If the Instructing Party parent BIC is filled in, the Instructing Party BIC has to be filled in too.</p> |
| Instructing Party BIC  | <p>Select the BIC of the instructing party from the drop-down menu or search via the <i>magnifier</i> icon.</p> <p>Required format is: max. 11 characters (SWIFT-x)</p> <p>References for error messages [ ▶ 994]:</p> <ul style="list-style-type: none"><li><input type="checkbox"/> MVCV110</li><li><input type="checkbox"/> MVCV230</li><li><input type="checkbox"/> MVDC003</li><li><input type="checkbox"/> MVDC005</li><li><input type="checkbox"/> MVDC007</li><li><input type="checkbox"/> MVDC015</li><li><input type="checkbox"/> MVDC017</li><li><input type="checkbox"/> MVDC019</li><li><input type="checkbox"/> MVDC022</li></ul>   |

| Intra-Balance Movement    |  |
|---------------------------|--|
|                           | <input type="checkbox"/> MVDC023<br><input type="checkbox"/> MVDC025<br><input type="checkbox"/> MVCP120<br><input type="checkbox"/> MVLI868<br><br>In case the instructing party is not entered, the instructing party informed to the back end module will be the party you belong to. If the Instructing Party BIC is filled in, the Instructing Party Parent BIC has to be filled in too.  |
| Intended Settlement Date* | Enter the date from which the instruction becomes eligible to be submitted to settlement or use the <i>calendar</i> icon.<br><br>Required format is: YYYY-MM-DD<br><br>References for error messages [ 994]:<br><br><input type="checkbox"/> MVCA508<br><input type="checkbox"/> MVLI819<br><input type="checkbox"/> MVLI820<br><input type="checkbox"/> MVLI821<br><input type="checkbox"/> MVLI822<br><input type="checkbox"/> MVLI823<br><input type="checkbox"/> MVLI824<br><input type="checkbox"/> MVLI835<br><input type="checkbox"/> MVLI836<br><input type="checkbox"/> MVRR903<br><input type="checkbox"/> MVRR989<br><input type="checkbox"/> MVSD404<br><input type="checkbox"/> MCVV110<br><input type="checkbox"/> MCVV230<br><input type="checkbox"/> MVLI834 |
| Corporate Action Event    | Enter the identification assigned by the account servicer to unambiguously identify a corporate action event.<br><br>Required format is: max. 16 characters (SWIFT-x-red)  |
| Priority                  | Select the level of priority assigned to the instruction from the possible values:<br><br><input type="checkbox"/> Empty (default value)   |

| Intra-Balance Movement             |   |
|------------------------------------|---|
|                                    | <input type="checkbox"/> Normal<br><input type="checkbox"/> High<br><input type="checkbox"/> Reserved<br>Reference for error message [ ▶ 994]:<br><input type="checkbox"/> MVSP212  |
| T2S Dedicated Cash Account Number* | Select the T2S dedicated cash account from the drop-down menu.<br><br>References for error messages [ ▶ 994]:<br><input type="checkbox"/> MVCA508<br><input type="checkbox"/> MVCA512<br><input type="checkbox"/> MVCP017<br><input type="checkbox"/> MCV291<br><input type="checkbox"/> MCV292<br><input type="checkbox"/> MVRR925<br><input type="checkbox"/> MVCP045 |
| Amount*                            | Enter the amount stated in the instruction.<br><br>Required format is: max. 15 digit(s) incl. decimal point (thereof max. 5 decimal places)<br><br>References for error messages [ ▶ 994]:<br><input type="checkbox"/> MVCU108<br><input type="checkbox"/> MCV255<br><input type="checkbox"/> MVCA106<br><input type="checkbox"/> MVSD404                               |
| T2S Dedicated Cash Account Owner   | Enter the BIC of the T2S dedicated cash account owner.<br><br>Required format is: max. 11 characters (SWIFT-x)<br><br>Reference for error message [ ▶ 994]:<br><input type="checkbox"/> MVCA512   |
| Currency                           | Shows the currency stated in the instruction obtained from the dedicated cash account.<br><br>It is automatically filled in when the T2S Dedicated Cash Account Number is selected.<br><br>References for error messages [ ▶ 994]:<br><input type="checkbox"/> MVCU102  |



| Intra-Balance Movement           |   |
|----------------------------------|---|
|                                  | <input type="checkbox"/> MVCU104<br><input type="checkbox"/> MVCA106<br><input type="checkbox"/> MVSD404  |
| Restriction Type - Balance From* | <p>You can choose to either enter the 'Restriction Type - Balance From' or to select it from the suggested items in the drop-down menu.</p> <p>This field also contains a description of the restriction.</p> <p>References for error messages [ ▶ 994]:</p> <input type="checkbox"/> MVRR901<br><input type="checkbox"/> MVRR905<br><input type="checkbox"/> MVRR906<br><input type="checkbox"/> MVRR910<br><input type="checkbox"/> MVRR917<br><input type="checkbox"/> MVRR924<br><input type="checkbox"/> MVRR993<br><input type="checkbox"/> MVRR994<br><input type="checkbox"/> MVCP098 |
| Restriction Type - Balance To*   | <p>You can choose to either enter the 'Restriction Type - Balance To' or to select it from the suggested items in the drop-down menu.</p> <p>This field also contains a description of the restriction.</p> <p>References for error messages [ ▶ 994]:</p> <input type="checkbox"/> MVRR905<br><input type="checkbox"/> MVRR906<br><input type="checkbox"/> MVRR910<br><input type="checkbox"/> MVRR916<br><input type="checkbox"/> MVRR924<br><input type="checkbox"/> MVRR989<br><input type="checkbox"/> MVRR992<br><input type="checkbox"/> MVRR993<br><input type="checkbox"/> MVRR994   |
| Restriction Reference            | <p>Enter the identification of the restriction applying on cash.</p> <p>Required format is: max. 16 characters (SWIFT-x-red)</p>  |

| Intra-Balance Movement |  |
|------------------------|--|
|                        | References for error messages [ ▶ 994]:<br><input type="checkbox"/> MVRR918<br><input type="checkbox"/> MVRR924<br><input type="checkbox"/> MVRR925<br><input type="checkbox"/> MVRR978<br><input type="checkbox"/> MVRR994  |
| Link                   |  |
| Link Type              | Select a link processing position from the possible values:<br><input type="checkbox"/> After (default value)<br><input type="checkbox"/> Before<br><input type="checkbox"/> With<br>References for error messages [ ▶ 994]:<br><input type="checkbox"/> MVCP018<br><input type="checkbox"/> MVLI805<br><input type="checkbox"/> MVLI806<br><input type="checkbox"/> MVLI807<br><input type="checkbox"/> MVLI819<br><input type="checkbox"/> MVLI820<br><input type="checkbox"/> MVLI821<br><input type="checkbox"/> MVLI822<br><input type="checkbox"/> MVLI823<br><input type="checkbox"/> MVLI824<br><input type="checkbox"/> MVLI834<br><input type="checkbox"/> MVLI835<br><input type="checkbox"/> MVLI836<br><input type="checkbox"/> MVLI852<br><input type="checkbox"/> MVLI855<br><input type="checkbox"/> MVLI858<br><input type="checkbox"/> MVLI861<br><input type="checkbox"/> MVLI864<br><input type="checkbox"/> MVLI866<br><input type="checkbox"/> MVLI873 |

| Intra-Balance Movement |  |
|------------------------|--|
|                        | <input type="checkbox"/> MVL1876<br>This field is also available as a show field for existing records.   |
| Reference Type         | Select the reference type of the instruction to be linked/unlinked to from the possible values: <ul style="list-style-type: none"> <li><input type="checkbox"/> Account Owner Settlement Instruction Reference</li> <li><input type="checkbox"/> Account Owner Settlement Instruction Reference</li> <li><input type="checkbox"/> Account Owner Intra Balance Movement Reference</li> <li><input type="checkbox"/> Account Owner Intra Position Movement Reference</li> <li><input type="checkbox"/> Account Servicer Reference</li> <li><input type="checkbox"/> Third Party reference</li> <li><input type="checkbox"/> T2S reference</li> </ul> Required format is: max. 35 characters (SWIFT-x)<br>Reference for error message [ ▶ 994]: <ul style="list-style-type: none"> <li><input type="checkbox"/> MVCP099</li> </ul> This field is also available as a show field for existing records. |
| Reference              | Enter the identification of the instruction to be linked/unlinked to. Required format is: max. 16 characters (SWIFT-x-red)<br>References for error messages [ ▶ 994]: <ul style="list-style-type: none"> <li><input type="checkbox"/> MVL1873</li> <li><input type="checkbox"/> MVL1869</li> <li><input type="checkbox"/> MVCP099</li> </ul> This field is also available as a show field for existing records.  |
| Reference Owner        | Enter the BIC of the instructing party of the instruction to be linked/unlinked to<br>Required format is: max. 11 characters (SWIFT-x)<br>If the 'Reference Type' is set to any value different than 'T2S reference' this field becomes mandatory.<br>This field is also available as a show field for existing records.   |

| Intra-Balance Movement     |  |
|----------------------------|--|
| Options                    | Information on functions (icons) can be found in Common Buttons and Icons [▶ 42].  |
| Pool Instruction Reference | <p>Enter the collective identification identifying a set of messages.</p> <p>Required format is: max. 16 characters (SWIFT-x-red)</p> <p>References for error messages [▶ 994]:</p> <ul style="list-style-type: none"> <li><input type="checkbox"/> MVCP018</li> <li><input type="checkbox"/> MVLI836</li> <li><input type="checkbox"/> MVLI848</li> <li><input type="checkbox"/> MVLI868</li> <li><input type="checkbox"/> MVLI876</li> </ul> |
| Pool Instruction Counter   | <p>Enter the identification of the pool counter.</p> <p>Required format is: Integer</p> <p>References for error messages [▶ 994]:</p> <ul style="list-style-type: none"> <li><input type="checkbox"/> MVLI844</li> <li><input type="checkbox"/> MVLI846</li> </ul> <p>This field becomes mandatory when the pool instruction reference is filled in.</p>   |
| Pool Reference Owner BIC   | <p>Enter the BIC of the owner of the Pool Instruction Reference.</p> <p>The field 'Pool Reference Owner BIC' becomes mandatory when the field 'Pool Instruction Reference' is filled in.</p>   |

## Buttons

|        |   |
|--------|---|
| Submit | <p>This function enables you to create a new intra-balance movement instruction. Upon clicking on the <i>submit</i> button you will be asked to enter your PIN for digital signature purposes (NRO). With the entry of the PIN, T2S attaches a digital signature to the instruction entered by the T2S actor.</p> <p>Next screen:</p> <ul style="list-style-type: none"> <li><input type="checkbox"/> <i>Intra-balance movements – search/list</i> screen [▶ 422]</li> </ul> <p>References for error messages [▶ 994]:</p> <ul style="list-style-type: none"> <li><input type="checkbox"/> MVCA106</li> <li><input type="checkbox"/> MVCA508</li> </ul> |
|--------|---|

- MVCA512
- MVCP017
- MVCP018
- MVCP045
- MVCP098
- MVCP099
- MVCP120
- MVCU102
- MVCU104
- MVCU108
- MCVV110
- MCVV230
- MCVV255
- MCVV291
- MCVV292
- MVDC003
- MVDC005
- MVDC007
- MVDC015
- MVDC017
- MVDC019
- MVDC022
- MVDC023
- MVDC025
- MVLI805
- MVLI806
- MVLI807
- MVLI819
- MVLI820
- MVLI821
- MVLI822
- MVLI823

- MVLI824
- MVLI834
- MVLI835
- MVLI836
- MVLI844
- MVLI846
- MVLI848
- MVLI852
- MVLI855
- MVLI858
- MVLI861
- MVLI864
- MVLI866
- MVLI868
- MVLI869
- MVLI873
- MVLI876
- MVRR901
- MVRR903
- MVRR905
- MVRR906
- MVRR910
- MVRR916
- MVRR917
- MVRR918
- MVRR924
- MVRR925
- MVRR978
- MVRR989
- MVRR992
- MVRR993
- MVRR994

|        |  |
|--------|--|
|        | <input type="checkbox"/> MVSD404<br><input type="checkbox"/> MVSP212<br><input type="checkbox"/> MVS705<br><input type="checkbox"/> MVS706<br><input type="checkbox"/> MVS708                      |
| Cancel | <p>This function enables you to cancel the process and return to the previous screen.</p> <p>Next screen:</p> <input type="checkbox"/> <i>Intra-balance movements – search/list</i> screen [▶ 422] |
| Reset  | <p>This function enables you to set all fields to default value and blanks out all optional fields.</p> <p>Next screen:</p> <input type="checkbox"/> <i>Intra-balance movement – new</i> screen    |

### 2.3.3.8 Maintenance Cash Instructions - Search/List Screen

#### Context of Usage

This screen contains a number of search fields. By inputting the relevant data, you can search for maintenance cash instructions. The search results will be displayed in a list. After selecting an entry, you can proceed further by clicking on the buttons below.

This screen is not relevant for CSD users.

#### Screen Access

Cash >> Settlement >> Maintenance Cash Instructions

#### Privileges

To use this screen, you need the following privileges [▶ 888]:

- Maintenance instruction for intra balance movements query
- Cancellation instruction for intra balance movements query
- Amendment instruction query for intra balance movements

#### References

##### User Instructions Part

This screen is part of the following business scenarios:

- View amendment instruction for a settlement restriction on cash details [▶ 772]
- View cancellation instruction for a settlement restriction on cash details [▶ 778]

### Business Functionality Document

This screen corresponds to the following business function:

- Query instruction (T2S.GUI.SESE.INX.0010)
- Display instruction list (T2S.GUI.SESE.INX.0020)

### Screenshot

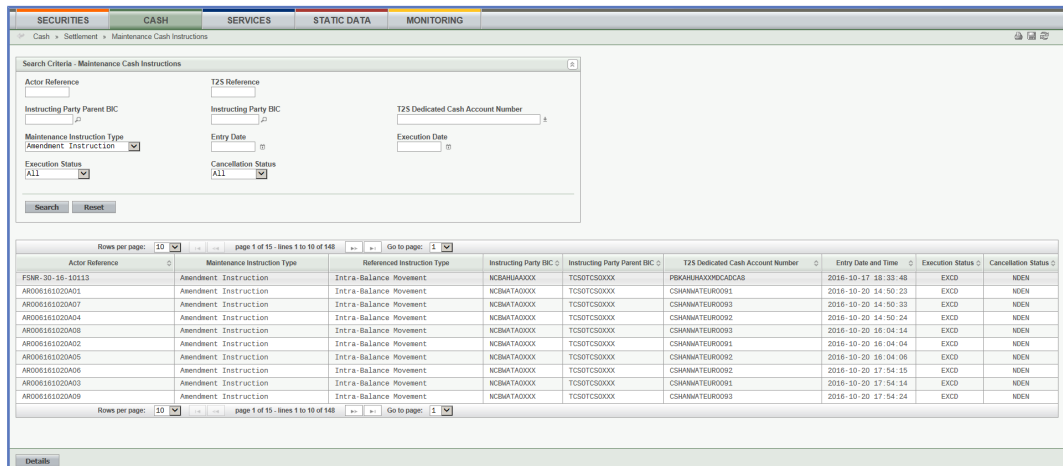

Illustration 92: Maintenance cash instructions - search/list screen

### Field Description

| Maintenance Cash Instructions – Search Criteria |   |
|---|---|
| Referenced Instruction                          |   |
| Actor Reference                                 | Enter the reference assigned by the T2S actor to the referenced settlement restriction on cash.<br>Required format is: max. 16 characters (SWIFT-x)   |
| T2S Reference                                   | Enter the identification of the reference assigned to the referenced settlement restriction on cash by T2S.<br>Required format is: max. 16 characters (SWIFT-x)   |
| General Criteria                                |   |
| Instructing Party BIC                           | You can choose to either enter the BIC of the instructing party or to select it from the suggested items in the drop-down menu.<br>Required format is: max. 11 characters (SWIFT-x)<br>References for error messages [ ▶ 1041]:<br><input type="checkbox"/> QMPC032<br><input type="checkbox"/> QMPC084 |
| Instructing Party Parent BIC                    | You can choose to either enter the parent BIC of the instructing party or to select it from the suggested items in the drop-down menu.<br>Required format is: max. 11 characters (SWIFT-x).<br>References for error messages [ ▶ 1041]:   |



| Maintenance Cash Instructions – Search Criteria |   |
|---|---|
|   | <input type="checkbox"/> QMPC048<br><input type="checkbox"/> QMPC084  |
| T2S Dedicated Cash Account Number               | Select the dedicated cash account from the drop-down menu.<br><br>Required format is: max. 34 characters (SWIFT-x)  |
| Maintenance Instruction Type                    | Select the type of the maintenance instruction from the possible values:<br><br><input type="checkbox"/> Cancellation instruction<br><input type="checkbox"/> Amendment instruction (default value)                         |
| Entry Date                                      | Enter the date when the maintenance instruction was created in T2S or use the <i>calendar</i> icon.<br><br>Required format is: YYYY-MM-DD<br>Reference for error message [▶ 1041]:<br><input type="checkbox"/> QMPC095      |
| Execution Date                                  | Enter the business date when the maintenance instruction has been executed or use the <i>calendar</i> icon.<br><br>Required format is: YYYY-MM-DD   |
| Status criteria                                 |   |
| Execution Status                                | Select the execution status of the maintenance instruction from the possible values:<br><br><input type="checkbox"/> All (default value)<br><input type="checkbox"/> Not executed<br><input type="checkbox"/> Executed      |
| Cancellation Status                             | Select the cancellation status of the maintenance instruction from the possible values:<br><br><input type="checkbox"/> All (default value)<br><input type="checkbox"/> Cancelled<br><input type="checkbox"/> Not cancelled |
| Maintenance Cash Instructions - List            |   |
| Actor Reference                                 | Shows the reference assigned by the T2S actor to the referenced settlement restriction on cash.   |
| Maintenance Instruction Type                    | Shows the type of maintenance instruction from the possible values:<br><br><input type="checkbox"/> Amendment instruction   |

| Maintenance Cash Instructions – Search Criteria |   |
|---|---|
|   | <input type="checkbox"/> Cancellation instruction   |
| Referenced Instruction Type                     | Shows the type of the referenced instruction.<br>The only possible value is 'Intra-Balance Movement'.   |
| Instructing Party BIC                           | Shows the BIC of the instructing party of the referenced settlement restriction.  |
| Instructing Party Parent BIC                    | Shows the parent BIC of the instructing party of the referenced settlement restriction.   |
| T2S Dedicated Cash Account Number               | Shows the number of the dedicated cash account.   |
| Entry Date and Time                             | Shows the date and time when the maintenance instruction has been created.  |
| Execution Status                                | Shows the execution status of the maintenance instruction from the possible values:<br><input type="checkbox"/> Not Executed<br><input type="checkbox"/> Executed |
| Cancellation Status                             | Shows the cancellation status of the maintenance instruction from the possible values:<br><input type="checkbox"/> Not denied<br><input type="checkbox"/> Denied  |

## Buttons

| Buttons |  |
|---------|--|
| Search  | <p>This function enables you to start a search according to the criteria entered. The results are displayed in a list on the next screen.</p> <p>If the search retrieves a single record, the <i>details</i> screen is displayed directly.</p> <p>Next screens:</p> <ul style="list-style-type: none"> <li><input type="checkbox"/> <i>Maintenance cash instructions – search/list</i> screen</li> <li><input type="checkbox"/> <i>Amendment cash instruction - details</i> screen [ ▶ 404]</li> <li><input type="checkbox"/> <i>Cancellation cash instruction - details</i> screen [ ▶ 416]</li> </ul> <p>References for error messages [ ▶ 1041]:</p> <ul style="list-style-type: none"> <li><input type="checkbox"/> QMPC031</li> <li><input type="checkbox"/> QMPC032</li> <li><input type="checkbox"/> QMPC048</li> <li><input type="checkbox"/> QMPC084</li> </ul> |

|         |   |
|---------|---|
|         | <ul style="list-style-type: none"> <li><input type="checkbox"/> QMPC095</li> </ul>  |
| Reset   | <p>This function enables you to set default search criteria and blanks out all optional criteria.</p> <p>Next screen:</p> <ul style="list-style-type: none"> <li><input type="checkbox"/> <i>Maintenance cash instructions – search/list</i> screen</li> </ul>  |
| Details | <p>This function enables you to display the details of the selected maintenance instruction.</p> <p>Next screens:</p> <ul style="list-style-type: none"> <li><input type="checkbox"/> <i>Amendment cash instruction – details</i> screen [▶ 404]</li> <li><input type="checkbox"/> <i>Cancellation cash instruction – details</i> screen [▶ 416]</li> </ul> |

### 2.3.3.9 Status History - Details Screen

See *Status History – Details* Screen [▶ 266].

## 2.4 Services

### 2.4.1 Additional Services

#### 2.4.1.1 Available Reports - Search/List Screen

**Context of Usage**

This screen contains a number of search fields. By inputting the relevant data, you can search for the latest available reports. The search results will be displayed in a list, which is sorted by the values of the 'Report Type' column in descending order (default setting). After selecting an entry, you can proceed further by clicking on the buttons below.

There is no usage restriction for this screen.

**Screen Access**

Services >> Additional Services >> Reports

**Privileges**

To use this screen, you need the following privilege [▶ 874]:

Report list query

**References**

**User Instructions Part**

This screen is part of the following business scenario:

View available reports

**Business Functionality Document**

This screen corresponds to the following business functions:

- Query generated reports (T2S.GUI.INSE.RPT.0070)
- Display generated reports list (T2S.GUI.INSE.RPT.0080)

**Screenshot**

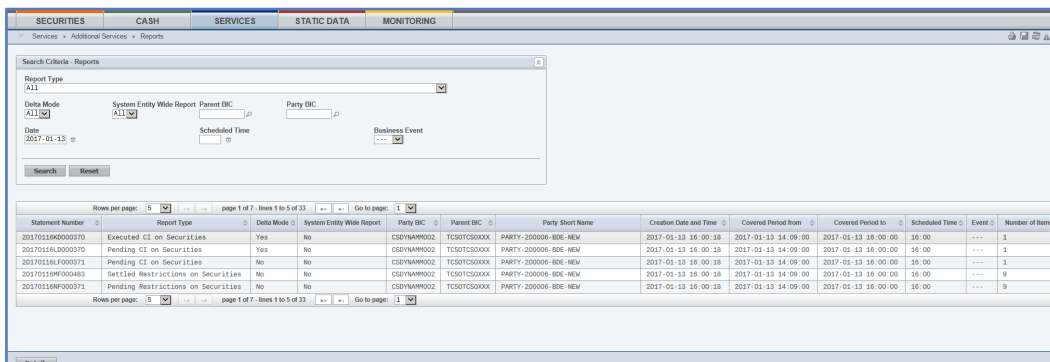

Illustration 93: Available reports - search/list screen

**Field Description**

| Available Reports – Search Criteria |   |
|-------------------------------------|---|
| Report Type                         | <p>Select the type of report from the possible values:</p> <ul style="list-style-type: none"> <li><input type="checkbox"/> All</li> <li><input type="checkbox"/> Statement of holdings</li> <li><input type="checkbox"/> Statement of transactions</li> <li><input type="checkbox"/> Statement of pending instructions</li> <li><input type="checkbox"/> Statement of settlement allegements</li> <li><input type="checkbox"/> Statement of accounts</li> <li><input type="checkbox"/> Current settlement day cash information report</li> <li><input type="checkbox"/> Daily Penalty List</li> <li><input type="checkbox"/> Following settlement day cash forecast report</li> <li><input type="checkbox"/> Following settlement day cash forecast report</li> <li><input type="checkbox"/> List of Modified Penalties</li> <li><input type="checkbox"/> Monthly Aggregated Amounts</li> <li><input type="checkbox"/> Statement of executed amendment instructions for intra-balance movements</li> <li><input type="checkbox"/> Statement of executed amendment instructions for intra-position movements and settlement instructions</li> <li><input type="checkbox"/> Statement of executed cancellation instructions for intra-balance movements</li> <li><input type="checkbox"/> Statement of executed cancellation instructions for intra-position movements and settlement instructions</li> <li><input type="checkbox"/> Statement of pending amendment instructions for intra-balance movements</li> </ul> |

| Available Reports – Search Criteria |  |
|-------------------------------------|--|
|                                     | <ul style="list-style-type: none"> <li><input type="checkbox"/> Statement of pending amendment instructions for intra-position movements and settlement instructions</li> <li><input type="checkbox"/> Statement of pending cancellation instructions for intra-balance movements</li> <li><input type="checkbox"/> Statement of pending cancellation instructions for intra-position movements and settlement instructions</li> <li><input type="checkbox"/> Statement of pending intra-balance movements</li> <li><input type="checkbox"/> Statement of pending intra-position movements</li> <li><input type="checkbox"/> Statement of settled intra-balance movements</li> <li><input type="checkbox"/> Statement of settled intra-position movements</li> </ul> |
| Delta Mode                          | <p>Select the mode of the report from the possible values:</p> <ul style="list-style-type: none"> <li><input type="checkbox"/> Yes</li> <li><input type="checkbox"/> No</li> <li><input type="checkbox"/> All (default value)</li> </ul>   |
| System Entity Wide Report           | <p>Select whether the report is a community report (covering all information referring to a system entity) or a party based report (covering all information referring to a party) from the possible values:</p> <ul style="list-style-type: none"> <li><input type="checkbox"/> Yes</li> <li><input type="checkbox"/> No</li> <li><input type="checkbox"/> All (default value)</li> </ul>   |
| Party BIC                           | <p>Select the BIC of the party.</p> <p>References for error messages [ ▶ 955]:</p> <ul style="list-style-type: none"> <li><input type="checkbox"/> QMPC032</li> <li><input type="checkbox"/> QMPC084</li> </ul>  |
| Parent BIC                          | <p>Select the parent BIC of the party whose data are reported.</p> <p>References for error messages [ ▶ 955]:</p> <ul style="list-style-type: none"> <li><input type="checkbox"/> QMPC048</li> <li><input type="checkbox"/> QMPC084</li> </ul>   |
| Date                                | <p>Enter the creation date of the report or use the <i>calendar</i> icon.</p> <p>Required format is: YYYY-MM-DD</p> <p>Reference for error message [ ▶ 955]:</p>   |

| Available Reports – Search Criteria |  |
|-------------------------------------|--|
|                                     | <input type="checkbox"/> QMPC055   |
| Scheduled Time                      | <p>Enter the scheduled time of the (business) event triggering the report creation.</p> <p>Required format is: hh:mm</p> <p>If this field is filled, the 'Business Event' field must not be filled and vice versa.</p>   |
| Business Event                      | <p>Select the business event.</p> <p>If this field is filled, the 'Scheduled Time' field must not be filled and vice versa.</p>  |
| Available Reports - List            |  |
| Statement Number                    | <p>Shows the statement number of the report composed of the business date and report type (2-letter abbreviation depending on report type and Delta/Full-Flag) and the sequential number, which is unique in T2S.</p> <p>The number increases for each report.</p> |
| Report Type                         | Shows the report type.   |
| Delta Mode                          | <p>Shows if the report is a delta report or not. Possible values are:</p> <p><input type="checkbox"/> Yes</p> <p><input type="checkbox"/> No</p>   |
| System Entity Wide Reports          | Shows whether the report is a community report (covering all information referring to a system entity) or a party based report (covering all information referring to a party).  |
| Party BIC                           | Shows the BIC of the data owning party.  |
| Parent BIC                          | Shows the parent BIC of the party whose data are reported.   |
| Party Short Name                    | Shows the short name of the party.   |
| Creation Date and Time              | <p>Shows the date and time of the report creation.</p> <p>Displayed format is: YYYY-MM-DD hh:mm:ss</p>   |
| Covered Period from                 | <p>Shows the date and time from which the data are covered in the report.</p> <p>Displayed format is: YYYY-MM-DD hh:mm:ss</p>  |
| Covered Period to                   | <p>Shows the date and time until which the data are covered in the report.</p> <p>Displayed format is: YYYY-MM-DD hh:mm:ss</p>   |

| Available Reports – Search Criteria |   |
|-------------------------------------|---|
| Scheduled Time                      | Shows the scheduled time which triggering the report creation.                  |
| Event                               | Shows the configured business event which triggered the creation of the report. |
| Number of Items                     | Shows the number of business items which are reported with this report.         |

**Buttons**

| Search  | <p>This function enables you to start a search according to the criteria entered. The results are displayed in a list on the same screen.</p> <p>If the search retrieves a single record, the <i>details</i> screen is displayed directly.</p> <p>Next screens:</p> <ul style="list-style-type: none"> <li><input type="checkbox"/> <i>Available reports – search/list</i> screen</li> <li><input type="checkbox"/> <i>Available report – details</i> screen [▶ 456]</li> </ul> <p>References for error messages [▶ 955]:</p> <ul style="list-style-type: none"> <li><input type="checkbox"/> QMPC032</li> <li><input type="checkbox"/> QMPC048</li> <li><input type="checkbox"/> QMPC055</li> <li><input type="checkbox"/> QMPC084</li> </ul> |
|---------|--|
| Reset   | <p>This function enables you to set default search criteria and blanks out all optional criteria.</p> <p>Next screen:</p> <ul style="list-style-type: none"> <li><input type="checkbox"/> <i>Available reports – search/list</i> screen</li> </ul>   |
| Details | <p>This function enables you to display the details of the selected report.</p> <p>Next screens:</p> <ul style="list-style-type: none"> <li><input type="checkbox"/> <i>Available report – [report type] details</i> screen [▶ 456] (In case the selected report consists of only 1 business item)</li> <li><input type="checkbox"/> <i>Available report – details</i> screen [▶ 456] (In case the selected report consists of more than 1 business item)</li> </ul>   |

## 2.4.1.2 Available Report - Details Screen

### Context of Usage

This screen displays detailed information on created reports. You can check the data and proceed further by clicking on the button below.

There is no usage restriction for this screen.

### Screen Access

Services >> Additional Services >> Reports >> Available reports – search/list screen >> Click on the search and/or details button

### Privileges

To use this screen, you need the following privileges [[▶ 869](#)]:

- Report list query
- Report details query

### References

#### User Instructions Part

This screen is part of the following business scenario:

- View available reports

#### Business Functionality Document

This screen corresponds to the following business function:

- Display generated reports list (T2S.GUI.INSE.RPT.0080)
- Generated reports query (T2S.GUI.INSE.RPT.0070)

### Screenshot

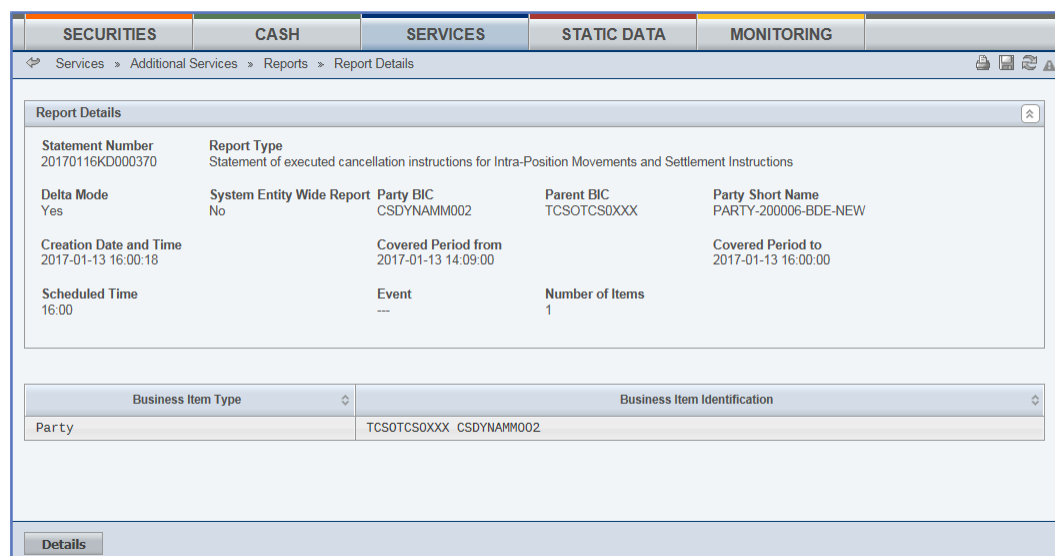

Illustration 94: Available report - details screen

### Field Description

| Report Information |   |
|--------------------|---|
| Statement Number   | Shows the statement number of the report composed of the business date and report type (2-letter-abbreviation depending on report type and delta/full-flag) and the sequential number, which is unique in T2S.<br>The number increases for each report. |
| Report Type        | Shows the type of the report.   |



| Report Information            |   |
|-------------------------------|---|
|                               | There is a predefined set of report types which are described in the published documents, e.g. statement of holdings.   |
| Delta Mode                    | Shows if the report is a delta report or not. Possible values are:<br><input type="checkbox"/> Yes<br><input type="checkbox"/> No   |
| System Entity Wide Report     | Shows whether the report is a community report (covering all information referring to a party) or a party based report (covering all information to a party) from the possible values:<br><input type="checkbox"/> Yes<br><input type="checkbox"/> No |
| Party BIC                     | Shows the BIC of the data owning party.   |
| Parent BIC                    | Shows the parent BIC of the party whose data are reported.  |
| Party Short Name              | Shows the short name of the party.  |
| Creation Date and Time        | Shows the date and time of the report creation.<br>Displayed format is: YYYY-MM-DD hh:mm:ss   |
| Covered Period from           | Shows the date and time from which the data are covered in the report.<br>Displayed format is: YYYY-MM-DD hh:mm:ss  |
| Covered Period to             | Shows the date and time until which the data are covered in the report.<br>Displayed format is: YYYY-MM-DD hh:mm:ss   |
| Scheduled Time                | Shows the scheduled time which triggered the report creation.<br>Displayed format is: hh:mm   |
| Event                         | Shows the configured business event which triggered the creation of the report.   |
| Number of Items               | Shows the number of business items which are reported with this report.   |
| Reported Business Item - List |   |
| Business Item Type            | Shows the information on the type of the report message segregating entity.   |

| Report Information           |  |
|------------------------------|--|
| Business Item Identification | Shows the business identifier of the reported business item (T2S Dedicated Cash Account Number, Securities Account Number, Currency Code or Party BIC).  |
| Button                       |  |
| Details                      | This function enables you to display the single business item of the selected report.<br><br>Next screen:<br><input type="checkbox"/> <i>Available report – [Report Type] – details</i> screen |

### 2.4.1.3 Available Report - Current Settlement Day Cash Information (Following Settlement Day Cash Forecast) Report - Details Screen

#### Context of Usage

This screen displays detailed information on the current settlement day cash information report (or on the selected settlement day cash information report for the following settlement day). These reports are similar and therefore described together.

The report projects the liquidity position at the end-of-day under consideration of settlement instructions, liquidity transfer orders and the calculated amount of outstanding credits in the system, at the moment of the report creation, which are valid for the current (or the following) business day.

The report displayed in this screen has to be already created in accordance with its report configuration.

This screen is not relevant for CSD, external CSD and CSD participant users.

#### Screen Access

- Services >> Additional Services >> Reports >> Available reports – search/list* screen >> Click on the *details* button
- Services >> Additional Services >> Reports >> Available reports – search/list* screen >> Click on the *search* and/or *details* button >> *Available report – details* screen >> Click on the *details* button

#### Privileges

To use this screen, you need the following privilege [**▶** 868]:

- Report details query

#### References

##### User Instructions Part

This screen is part of the following business scenario:

- View available reports

##### Business Functionality Document

This screen corresponds to the following business function:

Display generated report details (T2S.GUI.INSE.RPT.0090)

**Screenshot**

Illustration 95: Available report - current settlement day cash information - details screen

**Field Description**

| General Information |   |
|---------------------|---|
| Report Name         | Shows the name of the report.                             |
| Delta Mode          | Shows the delta mode of the report, which is always 'No'. |

| General Information                                       |   |
|---|---|
| Statement Number  | Shows the statement number of the report composed of the business date and report type (2-letter abbreviation depending on report type and delta/full-Flag) and the sequential number, which is unique in T2S.<br><br>The number increases for each report.                 |
| Report Number   | Shows the sequential number of the report which is specific for a report receiving party. This number will only be displayed if the sending user belongs to a report receiving party.   |
| Scheduled   | Shows the name of the business event or time triggering the report creation.  |
| Covered Period from                                       | Shows the date and time from which the data are covered in the report.<br><br>Displayed format is: YYYY-MM-DD hh:mm:ss  |
| Covered Period to   | Shows the date and time until which the data are covered in the report.<br><br>Displayed format is: YYYY-MM-DD hh:mm:ss   |
| Report Owner BIC  | Shows the BIC of the party whose data is reported on.   |
| Report Owner Parent BIC                                   | Shows the parent BIC of the party whose data is reported on.  |
| System Entity Wide Report                                 | Shows whether the report is a community report (covering all information referring to a system entity) or a party based report (covering all information referring to a party) from the possible values:<br><br><input type="checkbox"/> Yes<br><input type="checkbox"/> No |
| Forecast Date   | Shows the date of the current (or following) settlement day.<br><br>Displayed format is: YYYY-MM-DD   |
| <b>Statement</b>  |   |
| Repetitive Block For Each Reported Dedicated Cash Account |   |
| T2S Dedicated Cash Account Number                         | Shows the dedicated cash account number for which the report is created.  |
| Currency  | Shows the currency code.  |
| T2S Dedicated Cash Account Owner BIC                      | Shows the BIC of the party owning the T2S dedicated cash account.   |

| General Information                                       |   |
|---|---|
| T2S Dedicated Cash Account Owner Name                     | Shows the name of the party that owns the dedicated cash account.   |
| T2S Dedicated Cash Account Servicer BIC                   | Shows the BIC of the party operating the T2S dedicated cash account.  |
| <b>Balance</b>  |   |
| Repetitive Block For Each Reported Dedicated Cash Account |   |
| Balance Type  | Shows the type of the balance from the possible values: <ul style="list-style-type: none"> <li><input type="checkbox"/> Actual cash balance ('Sum of cash balance on the T2S dedicated cash account')</li> <li><input type="checkbox"/> Sum of Actual cash balance and pending liquidity transfers and settlement instructions eligible for cash forecast ('Projected sum of cash balance, liquidity transfer orders and settlement instructions')</li> <li><input type="checkbox"/> Outstanding intraday credit from auto-collateralisation</li> <li><input type="checkbox"/> Projected balance <sup>18</sup>, i.e. Sum of cash balance and pending LTs and SI and Amount of Outstanding intraday credit from auto-collateralisation ('Sum projected cash balance')</li> </ul> |
| Forecast Date   | Shows the current date or the date of the next settlement day.<br>Displayed format is: YYYY-MM-DD   |
| Debit Credit Indicator                                    | Shows if an operation is a credit or a debit from the possible values: <ul style="list-style-type: none"> <li><input type="checkbox"/> + (for 'Credit')</li> <li><input type="checkbox"/> - (for 'Debit')</li> </ul>  |
| Balance   | Shows the balance of the dedicated cash account.<br>There will be always one cash balance per balance type.   |
| <b>Expected Postings</b>                                  |   |
| Repetitive Block For Each Reported Dedicated Cash Account |   |

18 In UHB and T2S GUI, "projected balance" means the sum of cash balance and pending LTs and SIs and outstanding intraday credit from auto-collateralisation. In T2S UDFS and MyStandards, "projected balance" means the sum of cash balance and pending LTs and SIs (outstanding intraday credit from auto-collateralisation is not part of the calculation, i.e. is not subtracted).

| General Information         |  |
|-----------------------------|--|
| Posting Type                | <p>Shows the type of posting to be settled until end of day (or to be effective for the forecast day) from the possible values:</p> <ul style="list-style-type: none"> <li><input type="checkbox"/> Debiting valid and eligible settlement instructions (i.e. matched and ready for settlement)</li> <li><input type="checkbox"/> Debiting Settlement instructions, thereof non CORP released</li> <li><input type="checkbox"/> Debiting Settlement instructions, thereof non CORP on hold</li> <li><input type="checkbox"/> Debiting Settlement instructions, thereof CORP released</li> <li><input type="checkbox"/> Debiting Settlement instructions, thereof CORP on hold</li> <li><input type="checkbox"/> Crediting valid and eligible settlement instructions (i.e. matched and ready for settlement)</li> <li><input type="checkbox"/> Crediting Settlement instructions, thereof non CORP released</li> <li><input type="checkbox"/> Crediting Settlement instructions, thereof non CORP on hold</li> <li><input type="checkbox"/> Crediting Settlement instructions, thereof CORP released</li> <li><input type="checkbox"/> Crediting Settlement instructions, thereof CORP on hold</li> <li><input type="checkbox"/> Debiting liquidity transfer orders</li> </ul> |
| Number of Expected Postings | Shows the number of expected postings.   |
| Debit Credit Indicator      | <p>Shows if an operation is a credit or a debit from the possible values:</p> <ul style="list-style-type: none"> <li><input type="checkbox"/> + (for 'Credit')</li> <li><input type="checkbox"/> - (for 'Debit')</li> </ul>  |
| Expected postings           | Shows the total amount (including currency) expected for all postings of the same posting type, to be settled until end of day.  |

## 2.4.1.4 Available Report - Statement of Accounts - Details Screen

### Context of Usage

This screen displays detailed information on the selected statement of accounts. No new report will be created by entering this screen. The report will be displayed in a new window. The report displayed in this screen has to be already created in accordance with its report configuration.

For large reports the user has the option to view them in portions of up to 500 transactions. Only the current portion of the report will be available for a download or print.

This screen is not relevant for CSD, external CSD and CSD participant users.

### Screen Access

- Services >> Additional Services >> Reports >> *Available reports – search/list* screen >> Click on the *details* button
- Services >> Additional Services >> Reports >> *Available reports – search/list* screen >> Click on the *search* and/or *details* button >> *Available report – details* screen >> Click on the *details* button

### Privileges

To use this screen, you need the following privilege [[▶ 869](#)]:

- Report details query

### References

#### User Instructions Part

This screen is part of the following business scenario:

- View available reports

#### Business Functionality Document

This screen corresponds to the following business function:

- Display generated report details (T2S.GUI.INSE.RPT.0090)

### Screenshot

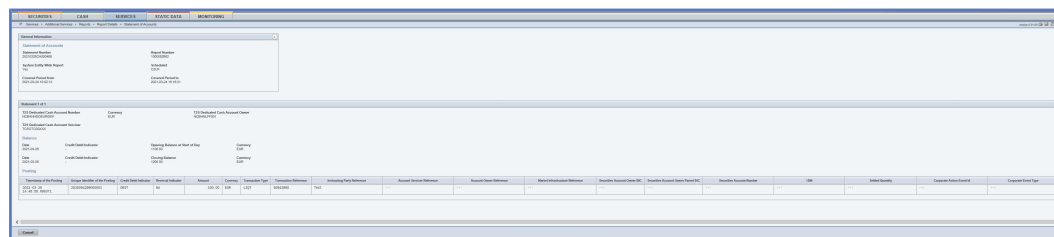

Illustration 96: Available report – statement of accounts – details screen

### Field Description

| General Statement Information |   |
|-------------------------------|---|
| Statement of Accounts         |   |
| Report Name                   | Shows the name of the report.                             |
| Delta Mode                    | Shows the delta mode of the report, which is always 'No'. |

| General Statement Information                             |   |
|---|---|
| Statement Number  | Shows the statement number of the report composed of the business date and report type (2-letter abbreviation depending on report type and Delta/Full-Flag) and the sequential number, which is unique in T2S.<br><br>The number increases for each report.                   |
| Report Number   | Shows the sequential number of the report which is specific for a report receiving party. This number will only be displayed if the sending user belongs to a report receiving party.   |
| Scheduled   | Shows the name of the business event or time triggering the report creation.  |
| Covered Period from                                       | Shows the date and time from which the data are covered in the report.<br><br>Displayed format is: YYYY-MM-DD hh:mm:ss  |
| Covered Period to   | Shows the date and time until which the data are covered in the report.<br><br>Displayed format is: YYYY-MM-DD hh:mm:ss   |
| Report Owner BIC  | Shows the BIC of the statement of accounts owning party.  |
| Report Owner Parent BIC                                   | Shows the parent BIC of the party whose statement of accounts is reported.  |
| System Entity Wide Report                                 | Shows whether the report is a community report (covering all information referring to a system entity) or a party based report (covering all information referring to a party)<br>possible values:<br><br><input type="checkbox"/> True<br><br><input type="checkbox"/> False |
| <b>Statement</b>  |   |
| Repetitive Block For Each Reported Dedicated Cash Account |   |
| T2S Dedicated Cash Account Number                         | Shows the T2S dedicated cash account number for which the report is created.  |
| Currency  | Shows the currency code.  |
| T2S Cash Account Owner BIC                                | Shows the BIC of the party that owns the T2S dedicated cash account.  |
| T2S Cash Account Servicer BIC                             | Shows the BIC of the party that operates the T2S dedicated cash account.  |
| <b>Balance</b>  |   |



| <b>General Statement Information</b>   |   |
|--|---|
| Repetitive Block For Each Balance Type (Opening/ Closing) Within Every Statement Block |   |
| Date   | Shows the date of the balance.<br>Displayed format is: YYYY-MM-DD   |
| Debit Credit Indicator   | Shows if an operation is a credit or a debit from the possible values:<br><input type="checkbox"/> + (for 'Credit')<br><input type="checkbox"/> - (for 'Debit') |
| Opening Balance at Start of Day/Closing Balance  | Shows the balance of the T2S dedicated cash account.  |
| Currency   | Shows the currency code.  |
| <b>Postings</b>  |   |
| <b>Repetitive Block For Each Reported Dedicated Cash Account</b>                       |   |
| Date and Time of the Posting   | Shows the date and the time when a booking took place.<br>Displayed format is: YYYY-MM-DD hh:mm:ss  |
| Posting Identifier   | Shows the unique identification of a posting in T2S.  |
| Debit Credit Indicator   | Shows if an operation is a credit or a debit from the possible values:<br><input type="checkbox"/> + (for 'Credit')<br><input type="checkbox"/> - (for 'Debit') |
| Reversal Indicator   | Indicates whether or not the entry is the result of a reversal. <sup>19</sup>   |
| Amount   | Shows the amount of money.  |
| Currency   | Shows the currency code.  |
| Transaction Type   | Shows the proprietary bank transaction code related to the underlying transaction type.   |
| Instructing Party Reference  | Shows the unique identification assigned by the instructing party of the underlying transaction.  |
| Transaction Reference  | Shows the unique identification assigned by the underlying clearing system.   |
| Account Servicer Reference   | Shows the account servicer reference of the settlement instruction.   |

<sup>19</sup> Please note that the described functionality won't be available before CSLD go-live.

| General Statement Information       |  |
|-------------------------------------|--|
|                                     | This field is only filled in, if the underlying instruction is a settlement instruction.   |
| Account Owner Reference             | Shows the account owner reference of the settlement instruction.<br><br>This field is only filled in, if the underlying instruction is a settlement instruction.                 |
| Market Infrastructure Reference     | Shows the identification of the settlement instruction as assigned by the T2S.<br><br>This field is only filled in, if the underlying instruction is a settlement instruction.   |
| Securities Account Owner BIC        | Shows the BIC of the party owning the securities account.<br><br>This field is only filled in, if the underlying instruction is a settlement instruction.                        |
| Securities Account Owner Parent BIC | Shows the parent BIC of the T2S party owning the securities account.<br><br>This field is only filled in, if the underlying instruction is a settlement instruction.             |
| Securities Account Number           | Shows the number of the securities account to which the Dedicated Cash Account that this report refers to is linked and which was booked with the respective securities quantity |
| ISIN                                | Shows the ISIN of the security booked  |
| Settled Quantity                    | Shows the quantity of securities that settled with this booking  |
| Corporate Action Event Id           | Shows the Corporate Action Event Id in case the Settlement Instruction is belonging to a Corporate Action  |
| Corporate Action Event Type         | Shows the value "OTHR", in case the Corporate Action Event Id is filled  |

### 2.4.1.5 Available Report - Statement of Executed Amendment Instructions for Intra-Balance Movements - Details Screen

#### Context of Usage

This screen displays detailed information on the selected statement of executed amendment instructions for intra-balance movements. The report in this screen has to be already created in accordance with its report configuration.

This screen is not relevant for CSD, external CSD and CSD participant users.

- Screen Access**
- Services >> Additional Services >> Reports >> *Available reports – search/list* screen >> Click on the *details* button
  - Services >> Additional Services >> Reports >> *Available reports – search/list* screen >> Click on the *details* button >> *Available report – details* screen >> Click on the *details* button

**Privileges** To use this screen you need the following privilege [▶ 869]:

- Report details query

**References** **User Instructions Part**

This screen is part of the following business scenario:

- View available reports

**Business Functionality Document**

This screen corresponds to the following business function:

- Display generated report details (T2S.GUI.INSE.RPT.0090)

**Screenshot**

| General Information  |  |
|--|--|
| <b>General Statement Information</b>   |  |
| Report<br>Statement of executed amendment instructions for Intra-Balance Movements | Delta Mode<br>Yes                        |
| Statement Number<br>20170116ID000171   | Report Number<br>1000003862              |
| Frequency<br>DAIL  | Scheduled<br>16:00                       |
| Activity Indicator<br>False  |  |
| Covered Period from<br>2017-01-13 14:09:00   | Covered Period to<br>2017-01-13 16:00:00 |
| Report Owner BIC<br>NCBKDEFFQ01  | Report Owner Parent BIC<br>TCSOTCS0XXX   |
| System Entity Wide Report<br>No  |  |

*Illustration 97: Available report - statement of executed amendment instructions for intra-balance movements - details screen*

| General Statement Information |   |
|-------------------------------|---|
| <b>Field Description</b>      |   |
| Report Name                   | Shows the name of the report  |
| Delta Mode                    | Shows if the report is a delta report or not. Possible values are:<br><input type="checkbox"/> Yes<br><input type="checkbox"/> No |

| General Statement Information          |   |
|--|---|
| Statement Number                       | Shows the statement number of the report composed of the business date and report type (2-letter abbreviation depending on report type and delta/full-flag) and the sequential number, which is unique in T2S.<br><br>The number increases for each report.                 |
| Report Number                          | Shows the sequential number of the report which is specific for a report receiving party. This number will only be displayed if the sending user belongs to a report receiving party.   |
| Frequency                              | Shows the frequency of the report, which is always 'DAILY'.   |
| Scheduled                              | Shows the name of the business event or time triggering the report creation.  |
| Activity Indicator                     | Shows whether the report displays activities or only lists information from the possible values:<br><br><input type="checkbox"/> True<br><input type="checkbox"/> False   |
| Covered Period from                    | Shows the date and time from which the data are covered in the report.<br><br>Displayed format is: YYYY-MM-DD hh:mm:ss  |
| Covered Period to                      | Shows the date and time until which the data are covered in the report.<br><br>Displayed format is: YYYY-MM-DD hh:mm:ss   |
| Report Owner BIC                       | Shows the BIC of the party whose data are reported.   |
| Report Owner Parent BIC                | Shows the parent BIC of the party whose data are reported.  |
| System Entity Wide Report              | Shows whether the report is a community report (covering all information referring to a system entity) or a party based report (covering all information referring to a party) from the possible values:<br><br><input type="checkbox"/> Yes<br><input type="checkbox"/> No |
| T2S Dedicated Cash Account Information |   |
| T2S Dedicated Cash Account Number      | Shows the T2S dedicated cash account number for which the report is created.  |

| General Statement Information   |   |
|---|---|
| T2S Dedicated Cash Account Owner BIC                                    | Shows the BIC of the party owning the T2S dedicated cash account.   |
| T2S Dedicated Cash Account Servicer BIC                                 | Shows the BIC of the party operating the T2S dedicated cash account.  |
| Processing Status of the Amendment Instruction                          |   |
| Repetitive Block For Each Amendment Instruction Of The Available Report |   |
| Last Update of Status   | Shows the date and time of the last status update.<br>Displayed format is: YYYY-MM-DD hh:mm:ss:μsμsμsμsμs   |
| Cancellation Status   | Shows the status of the amendment instruction from the possible values:<br><input type="checkbox"/> Canc (for 'Cancelled')<br><input type="checkbox"/> Ncan (for 'Not Cancelled')         |
| Execution Status  | Shows the execution status of the amendment instruction from the possible values:<br><input type="checkbox"/> Excd (for 'Executed')<br><input type="checkbox"/> Nexd (for 'Not Executed') |
| Cancellation Status Reason Code   | Shows the reason code for the cancellation.   |
| Cancellation Status Additional Information                              | Shows additional information on the cancellation status.  |
| Modification Information  |   |
| Actor Reference   | Shows the identification of the instruction assigned by the T2S actor.  |
| References assigned to the settlement restriction on the Cash Balance   |   |
| Account Owner Reference   | Shows the identification of the instruction assigned by the account owner.  |
| Account Servicer Reference  | Shows the identification of the instruction assigned by the account servicer.   |
| Amendment Instruction Technical Identifier                              | Shows the technical identification of the amendment instruction as assigned by T2S.   |
| Third Party Reference   | Shows the identification of the instruction assigned by a third party.  |

| General Statement Information  |  |
|--|--|
| Linkage Type of Instruction  | Shows the linkage type of the instruction from the possible values:<br><input type="checkbox"/> Link (for 'Linked')<br><input type="checkbox"/> Unlk (for 'Unlinked')  |
| Priority   | Shows the priority of the payment instruction assigned by the originator of the instruction from the possible values:<br><input type="checkbox"/> Normal<br><input type="checkbox"/> High<br><input type="checkbox"/> Top<br><input type="checkbox"/> Reserved |
| <b>Further information on underlying settlement restriction</b>                |  |
| <b>Repetitive Block For Each Linked Instruction</b>                            |  |
| Settlement Amount  | Shows the settlement amount which is restricted in the settlement restriction instruction.   |
| Intended Settlement Date   | Shows the date when the instruction is forwarded to settlement for the first time.<br>Displayed format is: YYYY-MM-DD  |
| Restriction Type Balance from  | Shows the code to identify the restriction type balance from.  |
| Restriction Type Balance to  | Shows the code to identify the restriction type balance to.  |
| Restriction Reference  | Shows the identification of the restriction assigned by T2S.   |
| Priority   | Shows the priority of the payment instruction assigned by the originator of the instruction from the possible values:<br><input type="checkbox"/> Normal<br><input type="checkbox"/> High<br><input type="checkbox"/> Top<br><input type="checkbox"/> Reserved |
| <b>Link Information</b>  |  |
| <b>Repetitive Block For Each Amendment Instruction Of The Available Report</b> |  |
| Link Type  | Shows the link type of the instruction from the possible values:   |

| General Statement Information                  |   |
|--|---|
|  | <input type="checkbox"/> Afte (for instruction has to be settled after or at the same time as the linked instruction)<br><input type="checkbox"/> Befo (for instruction has to be settled before or at the same time as the linked instruction)<br><input type="checkbox"/> With (for instruction has to be settled at the same time as the linked instruction)<br><input type="checkbox"/> Info (for specifies that the instructions are linked for information purposes only) |
| Actor Reference                                | Shows the identification of the instruction assigned by the T2S actor.  |
| Instructing Party BIC                          | Shows the BIC of the instructing party.   |
| Linked Instruction<br>T2S Technical Identifier | Shows the technical identification of the linked instruction.   |
| Message Number                                 | Shows the message number.   |

## 2.4.1.6 Available Report - Statement of Executed Amendment Instructions for Intra-Position Movements and Settlement Instructions - Details Screen

### Context of Usage

This screen displays detailed information on the selected statements of executed amendment instructions for intra-position movements and settlement instructions. The screen opens in a separate window.

This screen is not relevant for CB and payment bank users.

### Screen Access

- Services >> Additional Services >> Reports >> *Available reports – search/list* screen >> Click on the *details* button
- Services >> Additional Services >> Reports >> *Available reports – search/list* screen >> Click on the *details* button >> *Available report – details* screen >> Click on the *details* button

### Privileges

To use this screen, you need the following privilege [**▶** 870]:

- Report details query

### References

#### User Instructions Part

This screen is part of the following business scenario:

- View available reports

#### Business Functionality Document

This screen corresponds to the following business function:

- Display generated report details (T2S.GUI.INSE.RPT.0090)

### Screenshot

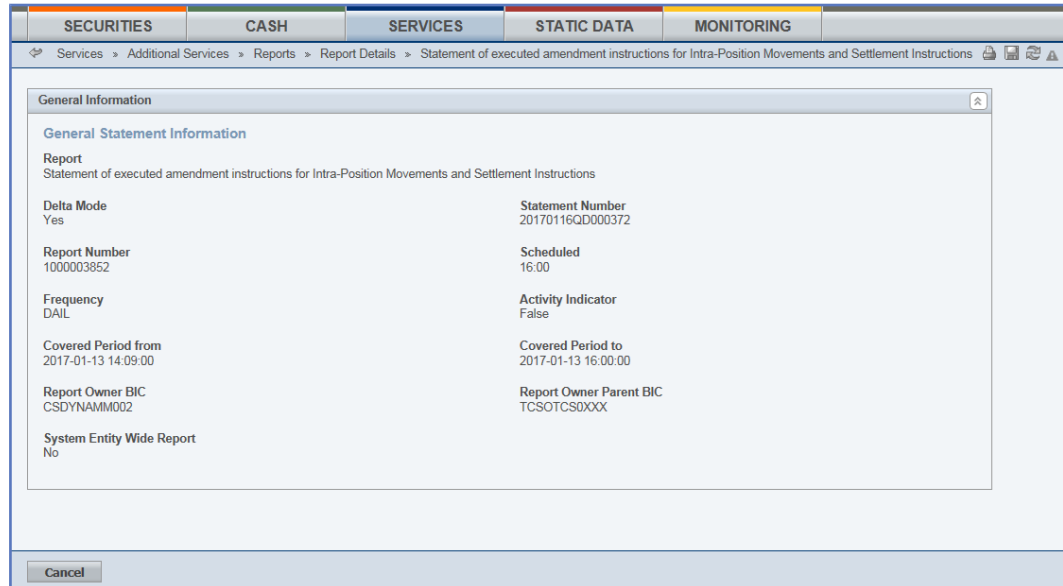

Illustration 98: Available report - statement of executed amendment instruction for intra-position movements and settlement instructions – details screen

### Field Description

| General Statement Information |   |
|-------------------------------|---|
| Report Name                   | Shows the name of the report.   |
| Delta Mode                    | Shows if the report is a delta report or not. Possible values are:<br><input type="checkbox"/> Yes<br><input type="checkbox"/> No   |
| Statement Number              | Shows the statement number of the report composed of the business date and report type (2-letter abbreviation depending on report type and delta/full-flag) and the sequential number, which is unique in T2S.<br><br>The number increases for each report. |
| Report Number                 | Shows the sequential number of the report which is specific for a report receiving party. This number will only be displayed if the sending user belongs to a report receiving party.   |
| Scheduled                     | Shows the business event or time or time triggering the report creation.  |
| Frequency                     | Shows the frequency of the report, which is always 'DAILY'.   |
| Activity Indicator            | Shows whether the report displays activities or only lists information from the possible values:  |



| General Statement Information  |   |
|--|---|
|  | <input type="checkbox"/> True<br><input type="checkbox"/> False   |
| Covered Period from  | Shows the date and time from which the data are covered in the report.<br>Displayed format is: YYYY-MM-DD hh:mm:ss  |
| Covered Period to  | Shows the date and time until which the data are covered in the report.<br>Displayed format is: YYYY-MM-DD hh:mm:ss   |
| Report Owner BIC   | Shows the BIC of the party whose data are reported.   |
| Report Owner Parent BIC  | Shows the parent BIC of the party whose data are reported.  |
| System Entity Wide Report  | Shows whether the report is a community report (covering all information referring to a system entity) or a party based report (covering all information referring to a party).<br>from the possible values:<br><input type="checkbox"/> Yes<br><input type="checkbox"/> No |
| Amendment Instruction or Hold/Release Instruction<br>Repetitive block for each amendment or hold/release instruction |   |
| Securities Account Information   |   |
| Securities Account Number  | Shows the number of the securities account.   |
| Securities Account Owner BIC   | Shows the BIC of the party owning the securities account.   |
| Securities Account Owner Parent BIC  | Shows the parent BIC of the party owning the securities account.  |
| Status Information   |   |
| Execution Status   | Shows the execution status of the instruction from the possible values:<br><input type="checkbox"/> EXCD (for executed)<br><input type="checkbox"/> NEXD (for not executed)   |
| Cancellation Status  | Shows the instruction status of the instruction from the possible values:<br><input type="checkbox"/> DEND (denied)<br><input type="checkbox"/> NDEN (not denied)   |

| General Statement Information   |   |
|---|---|
| Last update of Status   | Shows the date and time of the last status update.<br>Displayed format is: YYYY-MM-DD hh:mm:ss  |
| <b>Instruction Information for Hold/Release Instruction</b>                       |   |
| <b>This subframe is optional and only available for hold/release instructions</b> |   |
| Inbound Individual Message Identification   | Shows the technical identification number of the inbound individual message.  |
| Hold/Release Instruction Technical Identifier                                     | Shows the technical identification number of the hold/release instruction.  |
| Hold Status Type  | Shows the type of hold status of the instruction from the possible values: <ul style="list-style-type: none"> <li><input type="checkbox"/> CoSD hold</li> <li><input type="checkbox"/> CSD hold</li> <li><input type="checkbox"/> CSD validation hold</li> <li><input type="checkbox"/> Party hold</li> </ul>                   |
| On Hold Indicator   | Shows whether the instruction is on hold or not from the possible values: <ul style="list-style-type: none"> <li><input type="checkbox"/> Yes</li> <li><input type="checkbox"/> No</li> </ul>   |
| CoSD Rule Identification  | Shows the identification of the respective CoSD rule.   |
| <b>Instruction Information for amendment instructions</b>                         |   |
| <b>This subframe is optional and only available for amendment instructions</b>    |   |
| Amendment Instruction Technical Identifier  | Shows the unique identification of the amendment instruction assigned by T2S.   |
| Priority  | Shows the priority of the payment instruction assigned by the originator of the instruction from the possible values: <ul style="list-style-type: none"> <li><input type="checkbox"/> High</li> <li><input type="checkbox"/> Normal</li> <li><input type="checkbox"/> Reserved</li> <li><input type="checkbox"/> Top</li> </ul> |
| Partial Settlement Indicator  | Shows if the settlement instruction is allowed to be subject to partial settlement from the possible values:  |

| General Statement Information   |   |
|---|---|
|   | <input type="checkbox"/> NPAR (for no partial settlement allowed)<br><input type="checkbox"/> PART (for partial settlement allowed without restrictions)<br><input type="checkbox"/> PARC (for partial settlement allowed but the settlement amount must not be below the threshold)<br><input type="checkbox"/> PARQ (for partial settlement allowed but the quantity must not be below the threshold)                 |
| Instruction Information for amendment instructions - Linkage Information                    |   |
| This subframe is optional and only available for amendment instructions                     |   |
| Linkage Type of Instruction   | Shows the linkage type of the instruction from the possible values:<br><input type="checkbox"/> LINK (for linked)<br><input type="checkbox"/> UNLK (for unlinked)   |
| Instruction Information for amendment instructions - Linkage Information – Instruction Link |   |
| This subframe is optional and only available for amendment instructions                     |   |
| Link Type   | Shows the link type of the instruction from the possible values:<br><input type="checkbox"/> AFTE (Instruction has to be settled after or at the same time as the linked instruction)<br><input type="checkbox"/> BEFO (Instruction has to be settled before or at the same time as the linked instruction)<br><input type="checkbox"/> WITH (Instruction has to be settled at the same time as the linked instruction) |
| Linked Instruction T2S Technical Identifier   | Shows the identification of the linked instruction assigned by T2S.   |
| Linked Instruction Reference of Party   | Shows the T2S actor reference of the LCMM instruction with which the relevant LCMM instruction is linked.<br>If there is more than one link between LCMM instructions, the settlement link indicator is shown.  |
| Received Account Owner BIC  | Shows the BIC of the party who owns the identification of the instruction/pool to which this instruction is linked.   |
| System Entity Reference Owner   | Shows the identification of the system entity of the T2S party owner.   |

| General Statement Information   |  |
|---|--|
| Message Number  | Shows the identification of the message referenced in the linkage sequence.  |
| Pool Instruction Reference  | Shows the identification of the pool groups.   |
| To be modified instruction  |  |
| Intra-Position Movement Information   |  |
| <b>This subframe is optional and only available for intra-position movement information</b> |  |
| ISIN  | Shows the ISIN of the security.  |
| Original Settlement Quantity  | Shows the quantity of securities to be settled.  |
| Settlement Type   | Shows the type of settlement from the possible values:<br><input type="checkbox"/> UNIT<br><input type="checkbox"/> FAMT   |
| Intended Settlement Date  | Shows the date when the instruction is forwarded to settlement for the first time.<br><br>Displayed format is: YYYY-MM-DD  |
| Restriction Type Balance from   | Shows the restriction type code of a balance of a T2S dedicated cash account/position of a securities account which is debited.  |
| Restriction Type Balance to   | Shows a restriction type code of a balance of a T2S dedicated cash account/position of a securities account which is credited.   |
| Restriction Reference   | Shows the identification of the restriction assigned by T2S.   |
| Priority  | Shows the priority of the payment instruction assigned by the originator of the instruction from the possible values:<br><input type="checkbox"/> High<br><input type="checkbox"/> Normal<br><input type="checkbox"/> Reserved<br><input type="checkbox"/> Top |
| Intra-Position Movement Technical Identifier  | Shows the unique technical identification of the intra-position movement assigned by T2S.  |

| General Statement Information   |   |
|---|---|
| Account Owner Reference   | Shows the identification of the instruction assigned by the delivering/receiving party.   |
| Account Servicer Reference  | Shows the identification of the transaction assigned by the CSD.  |
| Third Party Reference   | Shows the identification of the instruction assigned by a third party.  |
| Settlement Instruction Information  |   |
| This subframe is optional and only available for settlement instruction information |   |
| Settlement Instruction Technical Identifier   | Shows the unique identification of the settlement instruction assigned by T2S.  |
| Account Owner Reference   | Shows the identification of the settlement instruction assigned by the delivering/receiving party.  |
| Account Servicer Reference  | Shows the identification of the settlement instruction assigned by the account servicer.  |
| Third Party Reference   | Shows the identification of the settlement instruction assigned by the third party.   |
| ISIN  | Shows the ISIN of the security.   |
| Original Settlement Quantity  | Shows the quantity of securities to be settled.   |
| Settlement Type   | Shows the type of settlement from the possible values:<br><input type="checkbox"/> UNIT (Units)<br><input type="checkbox"/> FAMT (Face amount)                    |
| Original Settlement Amount  | Shows the amount as stated in the settlement instruction.   |
| Settlement Currency   | Shows the unique code of the currency.  |
| Debit Credit Indicator  | Shows if an operation is a credit or a debit from the possible values:<br><input type="checkbox"/> CRDT (for credit)<br><input type="checkbox"/> DBIT (for debit) |
| Intended Settlement Date  | Shows the date when the instruction is forwarded to settlement for the first time.<br><br>Displayed format is: YYYY-MM-DD   |
| Trade Date  | Shows the date when the contract was made.  |

| <b>General Statement Information</b>  |  |
|---|--|
|   | Displayed format is: YYYY-MM-DD  |
| <b>Delivering Settlement Parties</b>  |  |
| This subframe is optional and only available for settlement instruction information   |  |
| <b>Delivering Depository</b>  |  |
| Party BIC   | Shows the BIC of the delivering depository.  |
| <b>Delivering CSD Participant</b>   |  |
| Party BIC   | Shows the BIC of the CSD participant delivering the securities.                              |
| Processing Identification   | Shows the unambiguous identification of the transaction as assigned by the delivering party. |
| <b>Settlement Instruction Information – Settlement Parties – Delivering Settlement Parties – Client of the Delivering CSD Participant</b> |  |
| <b>Specifying the party only via party BIC or its name or the triplet of identification, issuer and scheme name.</b>                      |  |
| Party BIC   | Shows the BIC of the client of delivering CSD participant.                                   |
| Identification  | Shows the proprietary identification of the pre-mentioned party BIC.                         |
| Issuer  | Shows the entity assigning the identification.   |
| Scheme Name   | Shows the name of the scheme.  |
| Name  | Shows the name of the client of delivering CSD participant.                                  |
| <b>Delivering Party 3</b>   |  |
| <b>Specifying the party only via party BIC or its name or the triplet of identification, issuer and scheme name.</b>                      |  |
| Party BIC   | Shows the BIC of 'Delivering Party 3'.   |
| Identification  | Shows the proprietary identification of the pre-mentioned party BIC.                         |
| Issuer  | Shows the entity assigning the identification.   |
| Scheme Name   | Shows the name of the scheme.  |
| Name  | Shows the name of 'Delivering Party 3'.  |
| <b>Delivering Party 4</b>   |  |
| <b>Specifying the party only via party BIC or its name or the triplet of identification, issuer and scheme name.</b>                      |  |
| Party BIC   | Shows the BIC of 'Delivering Party 4'.   |

| <b>General Statement Information</b>   |   |
|--|---|
| Identification   | Shows the proprietary identification of the pre-mentioned party BIC.                        |
| Issuer   | Shows the entity assigning the identification.  |
| Scheme Name  | Shows the name of the scheme.   |
| Name   | Shows the name of 'Delivering Party 4'.   |
| <b>Delivering Party 5</b>  |   |
| <b>Specifying the party only via party BIC or its name or the triplet of identification, issuer and scheme name.</b> |   |
| Party BIC  | Shows the BIC of 'Delivering Party 5'.  |
| Identification   | Shows the proprietary identification of the pre-mentioned party BIC.                        |
| Issuer   | Shows the entity assigning the identification. The fixed value is 'T2S'.                    |
| Scheme Name  | Shows the name of the scheme.   |
| Name   | Shows the name of 'Delivering Party 5'.   |
| Receiving Settlement Parties   |   |
| This subframe is optional and only available for settlement instruction information                                  |   |
| <b>Receiving Depository</b>  |   |
| Party BIC  | Shows the BIC of the receiving depository.  |
| Settlement Instruction Information – Settlement Parties – Receiving Settlement Parties – Receiving CSD Participant   |   |
| Party BIC  | Shows the BIC of the CSD receiving the securities.  |
| Processing Identification  | Shows the unambiguous identification of the transaction as assigned by the receiving party. |
| <b>Client of the Receiving CSD Participant</b>   |   |
| <b>Specifying the party only via party BIC or its name or the triplet of identification, issuer and scheme name.</b> |   |
| Party BIC  | Shows the BIC of the client of receiving CSD participant.                                   |
| Identification   | Shows the proprietary identification of the pre-mentioned party BIC.                        |
| Issuer   | Shows the entity assigning the identification.  |
| Scheme Name  | Shows the name of the scheme.   |
| Name   | Shows the name of the client of receiving CSD participant.                                  |

| General Statement Information  |  |
|--|--|
| <b>Receiving Party 3</b>   |  |
| <b>Specifying the party only via party BIC or its name or the triplet of identification, issuer and scheme name.</b> |  |
| Party BIC  | Shows the BIC of Receiving Party 3'.                                 |
| Identification   | Shows the proprietary identification of the pre-mentioned party BIC. |
| Issuer   | Shows the entity assigning the identification.                       |
| Scheme Name  | Shows the name of the scheme.  |
| Name   | Shows the name of Receiving Party 3'.                                |
| <b>Receiving Party 4</b>   |  |
| <b>Specifying the party only via party BIC or its name or the triplet of identification, issuer and scheme name.</b> |  |
| Party BIC  | Shows the BIC of 'Receiving Party 4'.                                |
| Identification   | Shows the proprietary identification of the pre-mentioned party BIC. |
| Issuer   | Shows the entity assigning the identification.                       |
| Scheme Name  | Shows the name of the scheme.  |
| Name   | Shows the name of 'Receiving Party 4'.                               |
| <b>Receiving Party 5</b>   |  |
| <b>Specifying the party only via party BIC or its name or the triplet of identification, issuer and scheme name.</b> |  |
| Party BIC  | Shows the BIC of 'Receiving Party 5'.                                |
| Identification   | Shows the proprietary identification of the pre-mentioned party BIC. |
| Issuer   | Shows the entity assigning the identification.                       |
| Scheme Name  | Shows the name of the scheme.  |
| Name   | Shows the name of 'Receiving Party 5'.                               |

### 2.4.1.7 Available Report - Statement of Executed Cancellation Instructions for Intra-Balance Movements - Details Screen

#### Context of Usage

This screen displays detailed information on the selected executed cancellation instruction for intra-balance movements.



The report displayed in this screen has to be already created in accordance with its report configuration.

This screen is not relevant for CSD, external CSD and CSD participant users.

### Screen Access

- Services >> Additional Services >> Reports >> *Available reports – search/list* screen >> Click on the *details* button
- Services >> Additional Services >> Reports >> *Available reports – search/list* screen >> Click on the *search* and/or *details* button >> *Available report – details* screen >> Click on the *details* button

### Privileges

To use this screen, you need the following privilege [**▶ 870**]:

- Report details query

### References

#### User Instructions Part

This screen is part of the following business scenario:

- View available reports

#### Business Functionality Document

This screen corresponds to the following business function:

- Display generated report details (T2S.GUI.INSE.RPT.0090)

### Screenshot

Illustration 99: Available report - statement of executed cancellation instructions for intra-balance movements - details screen

### Field Description

| General Statement Information |  |
|-------------------------------|--|
| Report Name                   | Shows the name of the report.  |
| Delta Mode                    | Shows if the report is a delta report or not. Possible values are:<br><input type="checkbox"/> Yes |

| General Statement Information   |   |
|---|---|
|   | <input type="checkbox"/> No   |
| Statement Number  | Shows the statement number of the report composed of the business date and report type (2-letter abbreviation depending on report type and Delta/Full-Flag) and the sequential number, which is unique in T2S.<br><br>The number increases for each report.                     |
| Report Number   | Shows the sequential number of the report which is specific for a report receiving party.<br><br>This number will only be displayed if the sending user belongs to a report receiving party.  |
| Frequency   | Shows the frequency of the report, which is always 'DAILY'.   |
| Scheduled   | Shows the name of the business event or time triggering the report creation.  |
| Activity Indicator  | Shows whether the report displays activities or only lists information from the possible values:<br><br><input type="checkbox"/> True<br><input type="checkbox"/> False   |
| Covered Period from   | Shows the date and time from which the data are covered in the report.<br><br>Displayed format is: YYYY-MM-DD hh:mm:ss  |
| Covered Period to   | Shows the date and time until which the data are covered in the report.<br><br>Displayed format is: YYYY-MM-DD hh:mm:ss   |
| Report Owner BIC  | Shows the BIC of the party whose data are reported.   |
| Report Owner Parent BIC   | Shows the parent BIC of the party whose data are reported.  |
| System Entity Wide Report   | Shows whether the report is a community report (covering all information referring to a system entity) or a party based report (covering all information referring to a party) from the possible values:<br><br><input type="checkbox"/> True<br><input type="checkbox"/> False |
| General Information Repetitive block for each cancellation instruction for Intra-Balance Movement |   |

| General Statement Information               |   |
|---|---|
| T2S Dedicated Cash Account Owner BIC        | Shows the BIC of the party owning the T2S dedicated cash account.   |
| T2S Dedicated Cash Account Owner Parent BIC | Shows the parent BIC of the party owning the dedicated cash account.  |
| T2S Dedicated Cash Account Number           | Shows the dedicated cash account number for which the report is created.  |
| Request Reference                           | Shows the reference number of the request   |
| Cancellation Status                         | Shows the status of the instruction from the possible values:<br><input type="checkbox"/> DEND (for denied)<br><input type="checkbox"/> NDEN (for not denied)               |
| Reason Code                                 | Shows the code of the reason why the instruction has a certain settlement status according to ISO20022.   |
| Reason Code Description                     | Shows the detailed description of the reason code.  |
| Execution Status                            | Shows the execution status of the instruction from the possible values:<br><input type="checkbox"/> EXCD (for executed)<br><input type="checkbox"/> NEXD (for not executed) |
| Reason Code                                 | Shows the code of the reason why the instruction has a certain settlement status according to ISO 20022.  |
| Reason Code Description                     | Shows the detailed description of the reason code.  |
| Last Update of Status                       | Shows the date and time of the last status update.<br>Displayed format is: YYYY-MM-DD hh:mm:ss:µsµsµsµsµs   |
| Referenced Instruction                      |   |
| <b>References</b>                           |   |
| Account Owner Reference                     | Shows the identification of the instruction assigned by the T2S delivering/receiving party.   |
| Account Servicer Reference                  | Shows the identification of the instruction assigned by the account servicer.   |
| Third Party Reference                       | Shows the identification of the instruction assigned by a third party.  |

| General Statement Information    |   |
|----------------------------------|---|
| Intra-Balance Movement Reference | Shows the identification of the intra-balance movement.   |
| Instruction Details              |   |
| Intended Settlement Date         | Shows the date when the instruction is forwarded to settlement for the first time.<br>Displayed format is: YYYY-MM-DD   |
| Priority                         | Shows the priority of the payment instruction assigned by the originator of the instruction from the possible values: <ul style="list-style-type: none"> <li><input type="checkbox"/> High</li> <li><input type="checkbox"/> Normal</li> <li><input type="checkbox"/> Reserved</li> <li><input type="checkbox"/> Top</li> </ul> |
| Settlement Amount                | Shows the amount as stated in the settlement instruction.   |
| Currency                         | Shows the currency code.  |
| Restriction Reference            | Shows the identification of the restriction assigned by T2S.  |
| Balance from Type                | Shows the code to identify the restriction type for the balance from.   |
| Issuer                           | Shows the entity assigning the identification. The fixed value is 'T2S'.  |
| Scheme Name                      | Shows the name of the scheme.   |
| Balance to Type                  | Shows the code to identify the restriction type for the balance to.   |
| Issuer                           | Shows the entity assigning the identification. The fixed value is 'T2S'.  |
| Scheme Name                      | Shows the name of the scheme.   |

### 2.4.1.8 Available Report - Statement of Executed Cancellation Instructions for Intra-Position Movements and Settlement Instructions - Details Screen

#### Context of Usage

This screen displays detailed information on the selected executed cancellation instructions for intra-position movements and settlement instruction. The report displayed in this screen has to be already created in accordance with its report configuration.

This screen is not relevant for CB and payment bank/settlement bank users.

- Screen Access**
- Services >> Additional Services >> Reports >> *Available reports – search/list* screen >> Click on the *details* button
  - Services >> Additional Services >> Reports >> *Available reports – search/list* screen >> Click on the *search* and/or *details* button >> *Available report – details* screen >> Click on the *details* button

**Privileges** To use this screen, you need the following privilege [**▶ 870**]:

- Report details query

**References** **User Instructions Part**

This screen is part of the following business scenario:

- View available reports

**Business Functionality Document**

This screen corresponds to the following business function:

- Display generated report details (T2S.GUI.INSE.RPT.0090)

**Screenshot**

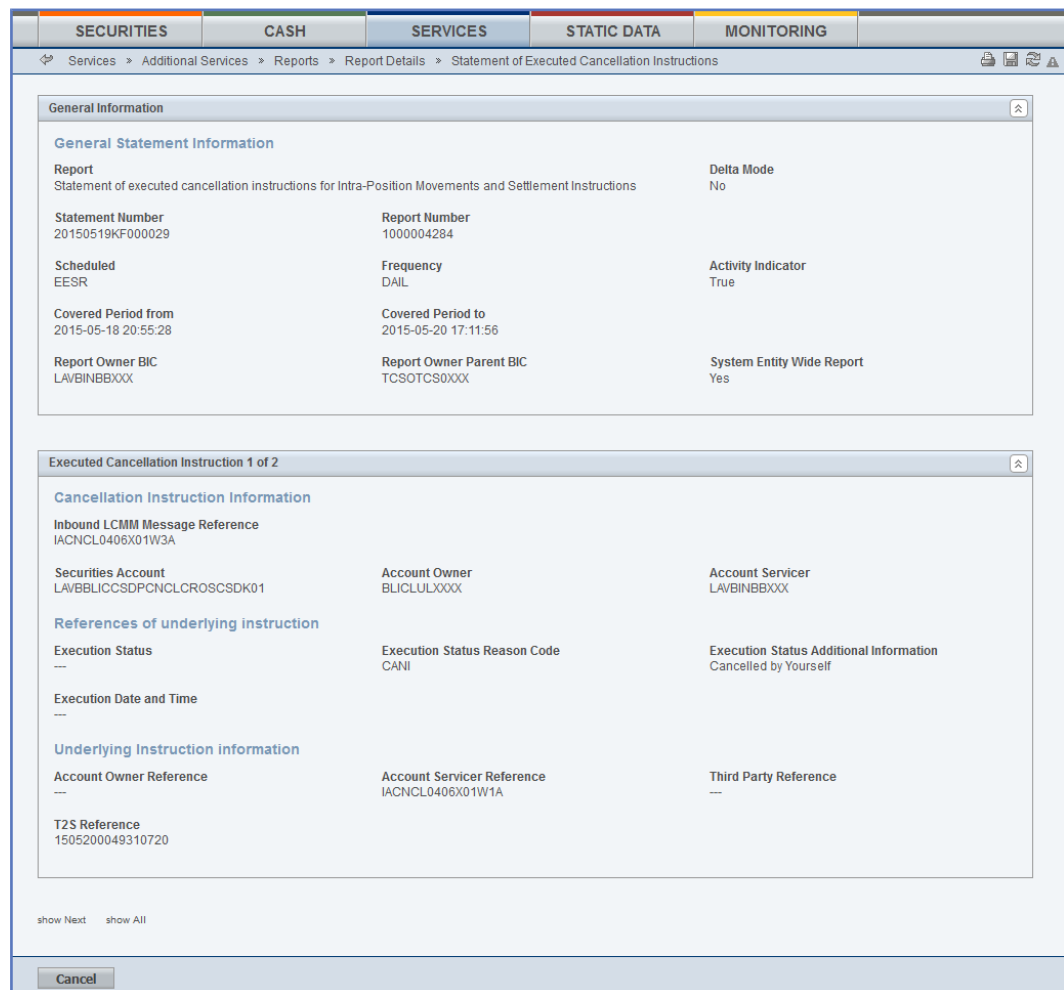

The screenshot displays the 'Statement of Executed Cancellation Instructions' details screen. The interface features a navigation bar with tabs for SECURITIES, CASH, SERVICES, STATIC DATA, and MONITORING. The main content is organized into two primary sections:

- General Information:** This section provides a summary of the report, including:
  - General Statement Information:** Report (Statement of executed cancellation instructions for Intra-Position Movements and Settlement Instructions), Delta Mode (No), Statement Number (20150519KF000029), Report Number (100004284), Scheduled (EESR), Frequency (DAIL), Activity Indicator (True), Covered Period from (2015-05-18 20:55:28), Covered Period to (2015-05-20 17:11:56), Report Owner BIC (LAVBINBBXXX), Report Owner Parent BIC (TCSOTCS0XXX), and System Entity Wide Report (Yes).
- Executed Cancellation Instruction 1 of 2:** This section details a specific instruction:
  - Cancellation Instruction Information:** Inbound LCMM Message Reference (IACNCL0406X01W3A), Securities Account (LAVBBLICSDPCNLCROSCSDK01), Account Owner (BLICLULXXX), and Account Servicer (LAVBINBBXXX).
  - References of underlying instruction:** Execution Status (---), Execution Status Reason Code (CANI), and Execution Status Additional Information (Cancelled by Yourself).
  - Execution Date and Time:** ---
  - Underlying Instruction information:** Account Owner Reference (---), Account Servicer Reference (IACNCL0406X01W1A), and Third Party Reference (---).
  - T2S Reference:** 1505200049310720

At the bottom of the screen, there are 'show Next' and 'show All' options, and a 'Cancel' button.

*Illustration 100: Available report - statement of executed cancellation instructions for intra-position movements and settlement instructions - details screen*

| Field<br>Description      | General Statement Information |   |
|---------------------------|-------------------------------|---|
| Report Name               |                               | Shows the name of the report.   |
| Delta Mode                |                               | Shows if the report is a delta report or not. Possible values are:<br><br><input type="checkbox"/> Yes<br><br><input type="checkbox"/> No   |
| Statement Number          |                               | Shows the statement number of the report composed of the business date and report type (2-letter abbreviation depending on report type and Delta/Full-Flag) and the sequential number, which is unique in T2S.<br><br>The number increases for each report. |
| Report Number             |                               | Shows the sequential number of the report which is specific for a report receiving party.<br><br>This number will only be displayed if the sending user belongs to a report receiving party.  |
| Frequency                 |                               | Shows the frequency of the report from the possible value:<br><br><input type="checkbox"/> DAILY (for reports created on a daily basis)   |
| Scheduled                 |                               | Shows the name of the business event or time triggering the report creation.  |
| Activity Indicator        |                               | Shows whether the report displays activities or only lists information from the possible values:<br><br><input type="checkbox"/> True<br><br><input type="checkbox"/> False   |
| Covered Period from       |                               | Shows the date and time from which the data are covered in the report.<br><br>Displayed format is: YYYY-MM-DD hh:mm:ss  |
| Covered Period to         |                               | Shows the date and time until which the data are covered in the report.<br><br>Displayed format is: YYYY-MM-DD hh:mm:ss   |
| Report Owner BIC          |                               | Shows the BIC of the party whose data are reported.   |
| Report Owner Parent BIC   |                               | Shows the parent BIC of the party whose data are reported.  |
| System Entity Wide Report |                               | Shows whether the report is a community report (covering all information referring to a system entity) or a party based report (covering all information referring to a party) from the possible values:  |

| General Statement Information                     |   |
|---|---|
|   | <input type="checkbox"/> Yes<br><input type="checkbox"/> No   |
| Cancellation Instruction Information              |   |
| Inbound LCMM Message Reference                    | Shows the reference assigned for a cancellation instruction by the sending party.   |
| Securities Account Information                    |   |
| Securities Account Number                         | Shows the number of the securities account.   |
| Securities Account Owner BIC                      | Shows the BIC of the party owning the securities account.   |
| Securities Account Servicer BIC                   | Shows the BIC of the securities account owner system entity.  |
| Processing Status of the cancellation instruction |   |
| Execution Status                                  | Shows the execution status of the instruction from the possible values:<br><input type="checkbox"/> EXCD (for executed)<br><input type="checkbox"/> NEXD (for not executed) |
| Execution Status Reason Code                      | Shows the reason code according to ISO20022 why the related instruction is cancelled or the related cancellation request is executed.                                       |
| Execution Status Additional Information           | Shows additional information about the reason of the execution.   |
| Execution Date and Time                           | Shows the business date when the LCMM instruction is executed or totally settled.<br><br>Displayed format is: YYYY-MM-DD hh:mm:ss   |
| Underlying Instruction Information                |   |
| Account Owner Reference                           | Shows the reference of an instruction as assigned by the T2S delivering/receiving party.  |
| Account Servicer Reference                        | Shows the identification of the transaction assigned by the account servicer.   |
| Third Party Reference                             | Shows the identification of the instruction assigned by a third party.  |
| T2S Reference                                     | Shows the identification of the instruction assigned by T2S.  |

| General Statement Information            |   |
|--|---|
| ISIN                                     | Shows the ISIN of the security.   |
| Instruction Type                         | Shows the type of the instruction from the possible values: <ul style="list-style-type: none"> <li><input type="checkbox"/> SI (for settlement instruction)</li> <li><input type="checkbox"/> SR (for settlement restriction)</li> </ul>  |
| Intended Settlement Date                 | Shows the date when the instruction is forwarded to settlement for the first time.<br>Displayed format is: YYYY-MM-DD   |
| Trade Date                               | Shows the date when the contract was made.<br>Displayed format is: YYYY-MM-DD   |
| Original Settlement Unit                 | Shows the number of securities which shall be settled.  |
| Original Settlement Quantity Face Amount | Shows the face amount of securities which shall be settled.   |
| Original Settlement Amount               | Shows the amount as stated in the settlement instruction.   |
| Currency                                 | Shows the currency code.  |
| Debit Credit Indicator                   | Shows if an operation is a credit or a debit from the possible values: <ul style="list-style-type: none"> <li><input type="checkbox"/> CRDT (for credit)</li> <li><input type="checkbox"/> DBIT (for debit)</li> </ul>  |
| Priority                                 | Shows the priority of the payment instruction assigned by the originator of the instruction from the possible values: <ul style="list-style-type: none"> <li><input type="checkbox"/> High</li> <li><input type="checkbox"/> Normal</li> <li><input type="checkbox"/> Reserved</li> <li><input type="checkbox"/> Top</li> </ul> |
| Restriction Reference                    | Shows the identification of the restriction assigned by T2S.  |
| Restriction Type Balance from            | Shows the code to identify the restriction type for the balance from  |
| Issuer                                   | Shows the entity assigning the identification.  |
| Scheme Name                              | Shows the name of the scheme.   |



| <b>General Statement Information</b>   |  |
|--|--|
| Restriction Type Balance to  | Shows the code to identify the restriction type for the balance to                           |
| Issuer   | Shows the entity assigning the identification.   |
| Scheme Name  | Shows the name of the scheme.  |
| <b>Settlement Parties</b>  |  |
| Delivering Settlement Parties  |  |
| This subframe is optional and only available for settlement instruction information                                  |  |
| <b>Delivering Depository</b>   |  |
| Party BIC  | Shows the BIC of the delivering depository.  |
| <b>Delivering CSD Participant</b>  |  |
| Party BIC  | Shows the BIC of the CSD participant delivering the securities.                              |
| Processing Identification  | Shows the unambiguous identification of the transaction as assigned by the delivering party. |
| <b>Client of the Delivering CSD Participant</b>  |  |
| <b>Specifying the party only via party BIC or its name or the triplet of identification, issuer and scheme name.</b> |  |
| Party BIC  | Shows the BIC of the client of delivering CSD participant.                                   |
| Identification   | Shows the proprietary identification of the pre-mentioned party BIC.                         |
| Issuer   | Shows the entity assigning the identification.   |
| Scheme Name  | Shows the name of the scheme.  |
| Name   | Shows the name of the client of delivering CSD participant.                                  |
| <b>Delivering Party 3</b>  |  |
| <b>Specifying the party only via party BIC or its name or the triplet of identification, issuer and scheme name.</b> |  |
| Party BIC  | Shows the BIC of delivering party 3.   |
| Identification   | Shows the proprietary identification of the pre-mentioned party BIC.                         |
| Issuer   | Shows the entity assigning the identification.   |
| Scheme Name  | Shows the name of the scheme.  |
| Name   | Shows the name of delivering party 3.  |

| <b>General Statement Information</b>   |   |
|--|---|
| <b>Delivering Party 4</b>  |   |
| <b>Specifying the party only via party BIC or its name or the triplet of identification, issuer and scheme name.</b> |   |
| Party BIC  | Shows the BIC of delivering party 4.  |
| Identification   | Shows the proprietary identification of the pre-mentioned party BIC.                        |
| Issuer   | Shows the entity assigning the identification.  |
| Scheme Name  | Shows the name of the scheme.   |
| Name   | Shows the name of delivering party 4.   |
| <b>Delivering Party 5</b>  |   |
| <b>Specifying the party only via party BIC or its name or the triplet of identification, issuer and scheme name.</b> |   |
| Party BIC  | Shows the BIC of delivering party 5.  |
| Identification   | Shows the proprietary identification of the pre-mentioned party BIC.                        |
| Issuer   | Shows the entity assigning the identification.  |
| Scheme Name  | Shows the name of the scheme.   |
| Name   | Shows the name of delivering party 5.   |
| Receiving Settlement Parties   |   |
| This subframe is optional and only available for settlement instruction information                                  |   |
| <b>Receiving Depository</b>  |   |
| Party BIC  | Shows the BIC of the receiving depository.  |
| Underlying Instruction Information – Settlement Parties – Receiving Settlement Parties – Receiving CSD Participant   |   |
| Party BIC  | Shows the BIC of the CSD receiving the securities.  |
| Processing Identification  | Shows the unambiguous identification of the transaction as assigned by the receiving party. |
| <b>Client of the Receiving CSD Participant</b>   |   |
| <b>Specifying the party only via party BIC or its name or the triplet of identification, issuer and scheme name.</b> |   |
| Party BIC  | Shows the BIC of the client of receiving CSD participant.                                   |
| Identification   | Shows the proprietary identification of the pre-mentioned party BIC.                        |

| <b>General Statement Information</b>   |  |
|--|--|
| Issuer   | Shows the entity assigning the identification.                       |
| Scheme Name  | Shows the name of the scheme.  |
| Name   | Shows the name of the client of receiving CSD participant.           |
| <b>Receiving Party 3</b>   |  |
| <b>Specifying the party only via party BIC or its name or the triplet of identification, issuer and scheme name.</b> |  |
| Party BIC  | Shows the BIC of receiving party 3.                                  |
| Identification   | Shows the proprietary identification of the pre-mentioned party BIC. |
| Issuer   | Shows the entity assigning the identification.                       |
| Scheme Name  | Shows the name of the scheme.  |
| Name   | Shows the Name of receiving party 3.                                 |
| <b>Receiving Party 4</b>   |  |
| <b>Specifying the party only via party BIC or its name or the triplet of identification, issuer and scheme name.</b> |  |
| Party BIC  | Shows the BIC of receiving party 4.                                  |
| Identification   | Shows the proprietary identification of the pre-mentioned party BIC. |
| Issuer   | Shows the entity assigning the identification.                       |
| Scheme Name  | Shows the name of the scheme.  |
| Name   | Shows the Name of receiving party 4.                                 |
| <b>Receiving Party 5</b>   |  |
| <b>Specifying the party only via party BIC or its name or the triplet of identification, issuer and scheme name.</b> |  |
| Party BIC  | Shows the BIC of receiving party 5.                                  |
| Identification   | Shows the proprietary identification of the pre-mentioned party BIC. |
| Issuer   | Shows the entity assigning the identification.                       |
| Scheme Name  | Shows the name of the scheme.  |
| Name   | Shows the Name of receiving party 5.                                 |

## 2.4.1.9 Available Report - Statement of Holdings - Details Screen

|                         |  |
|-------------------------|--|
| <b>Context of Usage</b> | <p>This screen displays detailed information on the selected statement of holdings. No new report will be created by entering this screen. The statement provides information on the securities that are held within a securities account at the time of the report creation.</p> <p>This screen is not relevant for CB and payment bank/settlement bank users.</p>  |
| <b>Screen Access</b>    | <ul style="list-style-type: none"><li><input type="checkbox"/> Services &gt;&gt; Additional Services &gt;&gt; Reports &gt;&gt; <i>Available reports – search/list</i> screen &gt;&gt; Click on the <i>details</i> button</li><li><input type="checkbox"/> Services &gt;&gt; Additional Services &gt;&gt; Reports &gt;&gt; <i>Available reports – search/list</i> screen &gt;&gt; Click on the <i>search</i> and/or <i>details</i> button &gt;&gt; <i>Available report – details</i> screen &gt;&gt; Click on the <i>details</i> button</li></ul> |
| <b>Privileges</b>       | <p>To use this screen, you need the following privilege [<a href="#">▶ 870</a>]:</p> <ul style="list-style-type: none"><li><input type="checkbox"/> Report details query</li></ul>   |
| <b>References</b>       | <p><b>User Instructions Part</b></p> <p>This screen is part of the following business scenario:</p> <ul style="list-style-type: none"><li><input type="checkbox"/> View available reports</li></ul> <p><b>Business Functionality Document</b></p> <p>This screen corresponds to the following business function:</p> <ul style="list-style-type: none"><li><input type="checkbox"/> Display generated report details (T2S.GUI.INSE.RPT.0090)</li></ul>   |

Screenshot

The screenshot displays a web application interface for viewing details of a settlement report. The top navigation bar includes tabs for SECURITIES, CASH, SERVICES, STATIC DATA, and MONITORING. The main content area is divided into several sections:

- General Information:** Contains fields for Report Name (Statement of Settlement Aligements), Delta Mode (No), Statement Number (20200221AF00151), Report Number (100025662), Frequency (DAIL), Scheduled (EESR), Activity Indicator (True), Covered Period from (2020-02-20 10:04:15), Covered Period to (2020-02-24 09:28:19), Report Owner BIC (CSDNLA0XXX), Report Owner Parent BIC (TCSOTCSBXXX), and System Entity Wide Report (Yes).
- Party Information:** Shows Alleged Party BIC (CSDNLA0XXX) and Alleged Party Parent BIC (TCSOTCSBXXX).
- Settlement Aligement 1 of 1:** Includes Instruction References (Account Owner Reference, Account Servicer Reference, Third Party Reference, Common Reference, Unique T2S Technical Identifier), Aligement Status, and Trade Timeline (Trade Date, Settlement Date).
- Trade Information:** Details Securities Movement Type (DELU), Payment Type (APMT), Beneficial Ownership (No), Place of Trade, Proprietary Identification, Issuer, Schema Name, ISIN (NLCDNL000023), Name (CSDNLA0XXX / NLCDNL000023), Deal Price, Yielded, Value Type, Rate %, Amount, Currency, and Number of Days Accrued.
- Settlement Amount:** Lists Settlement Quantity (60000), Settlement Type (UNIT), Credit Debit Indicator (CROT), Settlement Amount (90000), Settlement Currency (EUR), Original Ordered Amount (0), Original Ordered Currency (EUR), Unit Currency, Quoted Currency, Exchange Rate, and Resulting Amount.
- Status Information:** Shows Cum/Ex Indicator, ISO Transaction Type Code (TRAD), Settlement Transaction Condition Indicator, Partial Settlement Indicator (PARQ), and Market Client Side.
- Delivering Settlement Parties:** Identifies the Delivering CSD (CSDNLA0XXX), Delivering T2S Party (PMBDNL0XXX), and Delivering Party - Securities Account (CSDPCDNL0003).
- Receiving Settlement Parties:** Lists the Receiving CSD (CSDNLA0XXX) and Receiving T2S Party (PMBDNL0XXX).

Illustration 101: Available report – statement of holdings – details screen

Field  
Description

| General Statement Information |  |
|-------------------------------|--|
| Report Name                   | Shows the name of the report.  |
| Delta Mode                    | Shows if the report is a delta report or not. Possible values are:<br><input type="checkbox"/> Yes |

| General Statement Information |   |
|-------------------------------|---|
|                               | <input type="checkbox"/> No   |
| Statement Number              | Shows the statement number of the report composed of the business date and report type (2-letter abbreviation depending on report type and Delta/Full-Flag) and the sequential number, which is unique in T2S.<br><br>The number increases for each report. |
| Report Number                 | Shows the sequential number of the report which is specific for a report receiving party. This number will only be displayed if the sending user belongs to a report receiving party.   |
| Frequency                     | Shows the frequency of the report from the possible value:<br><br><input type="checkbox"/> DAILY (for reports created on a daily basis)   |
| Scheduled                     | Shows the name of the business event or time triggering the report creation.  |
| Activity Indicator            | Shows whether the report displays activities or only lists information from the possible values:<br><br><input type="checkbox"/> True<br><input type="checkbox"/> False   |
| Statement Basis               | Shows the basis of the statement from the possible value:<br><br><input type="checkbox"/> SETT (for settled)<br><br>The statement basis is a mandatory field in the message. The ISO message allows several possible values, but T2S allows only 'SETT'.    |
| Sub Account Indicator         | Shows if the statement reports holdings at subsafekeeping account level.  |
| Covered Period from           | Shows the date and time from which the data are covered in the report.<br><br>Displayed format is: YYYY-MM-DD hh:mm:ss  |
| Covered Period to             | Shows the date and time until which the data are covered in the report.<br><br>Displayed format is: YYYY-MM-DD hh:mm:ss   |
| Report Owner BIC              | Shows the BIC of the party whose data are reported.   |
| Report Owner Parent BIC       | Shows the parent BIC of the party whose data are reported.  |

| <b>General Statement Information</b>               |  |
|--|--|
| System Entity Wide Report                          | Shows whether the report is a community report (covering all information referring to a system entity) or a party based report (covering all information referring to a party) from one of the possible values:<br><br><input type="checkbox"/> True<br><input type="checkbox"/> False |
| <b>Securities Account Information</b>              |  |
| <b>Securities Account Information</b>              |  |
| Securities Account Number                          | Shows the number of the securities account on which the report is based.   |
| Securities Account Owner BIC                       | Shows the BIC of the party owning the securities account.  |
| Securities Account Servicer BIC                    | Shows the BIC of the party operating the securities account.   |
| <b>Information on the Positions of the Account</b> |  |
| <b>Total Position of a ISIN</b>                    |  |
| ISIN   | Shows the ISIN of the security.  |
| Position Type                                      | Shows the position of the ISIN from the possible values:<br><br><input type="checkbox"/> LONG (positive balance)<br><input type="checkbox"/> SHOR (negative balance)   |
| Settlement Type                                    | Shows the type of settlement from the possible values:<br><br><input type="checkbox"/> UNIT (Units)<br><input type="checkbox"/> FAMT (Face Amount)   |
| Total Quantity                                     | Shows the total quantity of the respective security.<br><br>Provision of '99999...99' in case oversizing occurs in the integer portion. Truncation of decimals in case oversizing occurs in the decimal portion.   |
| <b>Availability</b>                                |  |
| Settlement Type                                    | Shows the type of settlement from the possible values:<br><br><input type="checkbox"/> UNIT (Units)<br><input type="checkbox"/> FAMT (Face Amount)   |
| Available Balance                                  | Shows the total quantity the security that is available.   |

| General Statement Information                     |  |
|---|--|
|   | Provision of '99999...99' in case oversizing occurs in the integer portion. Truncation of decimals in case oversizing occurs in the decimal portion.   |
| Settlement Type                                   | Shows the type of settlement from the possible values:<br><input type="checkbox"/> UNIT (Units)<br><input type="checkbox"/> FAMT (Face Amount)   |
| Not Available Balance                             | Shows the total quantity of the security that is not available.<br><br>Provision of '99999...99' in case oversizing occurs in the integer portion. Truncation of decimals in case oversizing occurs in the decimal portion.  |
| Balance Breakdown per Restriction Processing Type |  |
| Restriction Processing Type                       | Shows the type of restriction processing.  |
| Settlement Type                                   | Shows the type of settlement from the possible values:<br><input type="checkbox"/> UNIT (Units)<br><input type="checkbox"/> FAMT (Face Amount)   |
| Quantity  | Shows the quantity of securities in the sub-balance for the market-specific restriction processing type.<br><br>Provision of '99999...99' in case oversizing occurs in the integer portion. Truncation of decimals in case oversizing occurs in the decimal portion. |
| Balance Breakdown per Restriction Type            |  |
| Restriction Type                                  | Shows the identification and description of a restriction.   |
| Settlement Type                                   | Shows the type of settlement from the possible values:<br><input type="checkbox"/> UNIT (Units)<br><input type="checkbox"/> FAMT (Face Amount)   |
| Quantity  | Shows the quantity of securities in the sub-balance for the market-specific restriction type.<br><br>Provision of '99999...99' in case oversizing occurs in the integer portion. Truncation of decimals in case oversizing occurs in the decimal portion.            |
| Quantity Breakdown per Restriction                |  |
| Restriction Reference                             | Shows the identification of the restriction assigned to a restricted securities position by T2S.   |



| General Statement Information |  |
|-------------------------------|--|
| Settlement Type               | Shows the type of settlement from the possible values: <ul style="list-style-type: none"> <li><input type="checkbox"/> UNIT (Units)</li> <li><input type="checkbox"/> FAMT (Face Amount)</li> </ul>            |
| Quantity                      | Shows the remaining quantity of a securities position.<br>Provision of '99999...99' in case oversizing occurs in the integer portion. Truncation of decimals in case oversizing occurs in the decimal portion. |

## 2.4.1.10 Available Report - Statement of Pending Amendment Instructions for Intra-Balance Movements - Details Screen

|                         |   |
|-------------------------|---|
| <b>Context of Usage</b> | <p>This screen displays detailed information on the selected statement of pending amendment instructions for intra-balance movements.</p> <p>The report displayed in this screen has to be already created in accordance with its report configuration.</p> <p>This screen is not relevant for CSD users, external CSD users or CSD participants.</p>   |
| <b>Screen Access</b>    | <ul style="list-style-type: none"> <li><input type="checkbox"/> Services &gt;&gt; Additional Services &gt;&gt; Reports &gt;&gt; <i>Available reports – search/list</i> screen &gt;&gt; Click on the <i>details</i> button</li> <li><input type="checkbox"/> Services &gt;&gt; Additional Services &gt;&gt; Reports &gt;&gt; <i>Available reports – search/list</i> screen &gt;&gt; Click on the <i>search</i> and/or <i>details</i> button &gt;&gt; <i>Available report – details</i> screen &gt;&gt; Click on the <i>details</i> button</li> </ul> |
| <b>Privileges</b>       | <p>To use this screen, you need the following privilege [<a href="#">▶ 871</a>]:</p> <ul style="list-style-type: none"> <li><input type="checkbox"/> Report details query</li> </ul>  |
| <b>References</b>       | <p><b>User Instructions Part</b></p> <p>This screen is part of the following business scenario:</p> <ul style="list-style-type: none"> <li><input type="checkbox"/> View available reports</li> </ul> <p><b>Business Functionality Document</b></p> <p>This screen corresponds to the following business function:</p> <ul style="list-style-type: none"> <li><input type="checkbox"/> Display generated report details (T2S.GUI.INSE.RPT.0090)</li> </ul>  |

Screenshot

**General Statement Information**

|  |   |
|--|---|
| Report Name<br><b>Report 1</b>               | Mode<br><b>DELTA</b>  |
| Statement Number<br><b>000000000012345</b>   | Report Number<br><b>12345</b>                                     |
| Frequency<br><b>ADHOC</b>                    | Scheduled<br><b>End of Day</b>                                    |
| Activity Indicator<br><b>True</b>            | Report Creation Date and Time<br><b>2012-07-05 13:12:54:89456</b> |
| Covered Period<br><b>2012-06-05 00:00:00</b> | Covered Period<br><b>2012-06-15 00:00:00</b>                      |
| Report Owner BIC<br><b>PAR1FRPPXXX</b>       | Report Owner Parent BIC<br><b>CSD2ITRDXXX</b>                     |
| System Entity Wide Report<br><b>No</b>       |   |

**T2S Dedicated Cash Account Information**

|  |  |   |
|--|--|---|
| T2S Dedicated Cash Account Number<br><b>1234567890</b> | T2S Dedicated Cash Account Owner BIC<br><b>CSD5ITRDXXX</b> | T2S Dedicated Cash Account Servicer BIC<br><b>PAR3FRPPXXX</b> |
|--|--|---|

**Processing Status**

**Processing Status of the Amendment Instruction**

|   |   |  |
|---|---|--|
| Last Update of Status<br><b>2012-06-11 10:22:12:00000</b> | Cancellation Status<br><b>NDEN</b>            |  |
| Execution Status<br><b>NEXD</b>                           | Cancellation Status Reason Code<br><b>---</b> | Cancellation Status Additional Information<br><b>---</b> |

**Modification Information**

|   |   |   |
|---|---|---|
| Actor Reference<br><b>12345</b>         | T2S Dedicated Cash Account Servicer Reference<br><b>54321</b> | Amendment Instruction Technical Identifier<br><b>T2S-A-009-AA</b> |
| Third Party Reference<br><b>3RD_BXX</b> | Linkage Type of Instruction<br><b>LINK</b>                    | Priority<br><b>Normal</b>   |

**Link Information**

| Link Type | User Reference | Instructing Party BIC | Instructing Party Parent BIC | Linked Instruction T2S Technical Identifier | Message Number |
|-----------|----------------|-----------------------|------------------------------|---|----------------|
| INFO      | REF-2012-L-2   | PAR1FRPPXXX           | CSD1DEFFXXX                  | TECH-ID-12-827301                           | MSG-ID-3554-12 |
| WITH      | REF-2012-L-1   | PAR1FRPPXXX           | CSD1DEFFXXX                  | TECH-ID-12-827299                           | MSG-ID-3421-12 |

**Further Information on Underlying Settlement Restriction**

|   |   |                                       |
|---|---|---------------------------------------|
| Settlement Amount<br><b>123,123,123.12345</b> | Intended Settlement Date<br><b>2012-06-12</b> |                                       |
| Restriction Type Balance from<br><b>DELI</b>  | Restriction Type Balance To<br><b>BLK1</b>    | Restriction Reference<br><b>34512</b> |
| Priority<br><b>Normal</b>                     |   |                                       |

Illustration 102: Available report – statement of pending amendment instruction for intra-balance movements – details screen

Field Description

| General Statement Information |  |
|-------------------------------|--|
| Report Name                   | Shows the name of the report.  |
| Delta Mode                    | Shows if the report is a delta report or not. Possible values are: <ul style="list-style-type: none"> <li><input type="checkbox"/> Yes</li> <li><input type="checkbox"/> No</li> </ul> |

| General Statement Information   |   |
|---|---|
| Statement Number  | Shows the statement number of the report composed of the business date and report type (2-letter abbreviation depending on report type and Delta/Full-Flag) and the sequential number, which is unique in T2S.<br><br>The number increases for each report.                 |
| Report Number   | Shows the sequential number of the report which is specific for a report receiving party.<br><br>This number will only be displayed if the sending user belongs to a report receiving party.  |
| Frequency   | Shows the frequency of the report, which is always 'DAILY'.   |
| Scheduled   | Shows the name of the business event or time triggering the report creation.  |
| Activity Indicator  | Shows whether the report displays activities or only lists information from the possible values:<br><br><input type="checkbox"/> True<br><input type="checkbox"/> False   |
| Covered Period From   | Shows the date and time from which the data are covered in the report.<br><br>Displayed format is: YYYY-MM-DD hh:mm:ss  |
| Covered Period To   | Shows the date and time until which the data are covered in the report.<br><br>Displayed format is: YYYY-MM-DD hh:mm:ss   |
| Report Owner BIC  | Shows the BIC of the party whose data are reported.   |
| Report Owner Parent BIC   | Shows the parent BIC of the party whose data are reported.  |
| System Entity Wide Report   | Shows whether the report is a community report (covering all information referring to a system entity) or a party based report (covering all information referring to a party) from the possible values:<br><br><input type="checkbox"/> Yes<br><input type="checkbox"/> No |
| T2S Dedicated Cash Account Information<br>Repetitive Block For Each Amendment Instruction |   |

| General Statement Information   |   |
|---|---|
| T2S Dedicated Cash Account Number                                     | Shows the T2S dedicated cash account for which the report is created.   |
| Account Owner Reference   | Shows the BIC of the party owning the T2S dedicated cash account.   |
| Account Servicer Reference  | Shows the BIC of the party operating the T2S dedicated cash account.  |
| Processing Status   |   |
| Repetitive Block For Each Amendment Instruction                       |   |
| Processing Status of the Amendment Instruction                        |   |
| Last Update of Status   | Shows the date and time of the last status update.<br>Displayed format is: YYYY-MM-DD hh:mm:ss:µsµsµsµsµs   |
| Cancellation Status   | Shows the status of the instruction from the possible values:<br><input type="checkbox"/> cancelled<br><input type="checkbox"/> not cancelled                               |
| Execution Status  | Shows the execution status of the instruction from the possible values:<br><input type="checkbox"/> EXCD (for executed)<br><input type="checkbox"/> NEXD (for not executed) |
| Cancellation Status Reason Code                                       | Shows the reason code for the cancellation.   |
| Cancellation Status Additional Information                            | Shows additional information on the cancellation status.  |
| Modification Information  |   |
| Actor Reference   | Shows the identification of the instruction assigned by the T2S actor.  |
| References assigned to the settlement restriction on the Cash Balance |   |
| Account Owner Reference   | Shows the identification of the instruction as assigned by the T2S Delivering/Receiving Party.  |
| Account Servicer Reference  | Shows the identification of the instruction as assigned by the account servicer.  |
| Amendment Instruction Technical Identifier                            | Shows the identification of the amendment instruction assigned by T2S.  |

| General Statement Information                            |  |
|--|--|
| Third Party Reference                                    | Shows the identification of the instruction assigned by a third party.   |
| Linkage Type of Instruction                              | Shows the linkage type of the instruction from the possible values: <ul style="list-style-type: none"> <li><input type="checkbox"/> LINK (for linked)</li> <li><input type="checkbox"/> UNLK (for unlinked)</li> </ul>   |
| Priority   | Shows the priority of the payment instruction assigned by the originator of the instruction from the possible values: <ul style="list-style-type: none"> <li><input type="checkbox"/> High</li> <li><input type="checkbox"/> Normal</li> <li><input type="checkbox"/> Reserved</li> <li><input type="checkbox"/> Top</li> </ul>  |
| Link Information   |  |
| Link Type  | Shows the link type of the instruction from the possible values: <ul style="list-style-type: none"> <li><input type="checkbox"/> AFTE (Instruction has to be settled after or at the same time as the linked instruction)</li> <li><input type="checkbox"/> BEFO (Instruction has to be settled before or at the same time as the linked instruction)</li> <li><input type="checkbox"/> WITH (Instruction has to be settled at the same time as the linked instruction)</li> </ul> |
| Actor Reference  | Shows the identification of the instruction assigned by the instructing party.   |
| Instructing Party BIC                                    | Shows the BIC of the instructing party.  |
| Linked Instruction T2S Technical Identifier              | Shows the technical identification of the linked instruction.  |
| Message Number   | Shows the ISO code of the XML message.   |
| Further Information on Underlying Settlement Restriction |  |
| Repetitive Block For Each Amendment Instruction          |  |
| Settlement Amount  | Shows the amount as stated in the settlement restriction.  |
| Intended Settlement Date                                 | Shows the date when the instruction is forwarded to settlement for the first time.<br><br>Displayed format is: YYYY-MM-DD  |

| General Statement Information |   |
|-------------------------------|---|
| Restriction Type Balance from | Shows the code to identify the restriction type for the balance from.   |
| Restriction Type Balance To   | Shows the code to identify the restriction type for the balance to.   |
| Restriction Reference         | Shows the identification of the restriction assigned by T2S.  |
| Priority                      | Shows the priority of the payment instruction assigned by the originator of the instruction from the possible values: <ul style="list-style-type: none"> <li><input type="checkbox"/> High</li> <li><input type="checkbox"/> Normal</li> <li><input type="checkbox"/> Reserved</li> <li><input type="checkbox"/> Top</li> </ul> |

### 2.4.1.11 Available Report - Statement of Pending Amendment Instructions for Intra-Position Movements and Settlement Instructions - Details Screen

#### Context of Usage

This screen displays detailed information on the selected statement of pending amendment instructions for intra-position movements and settlement instructions.

The report displayed in this screen has to be already created in accordance with its report configuration.

This screen is not relevant for CB and payment bank/settlement bank users.

#### Screen Access

Services >> Additional Services >> Reports >> *Available reports – search/list* screen >> Click on the *details* button

Services >> Additional Services >> Reports >> *Available reports – search/list* screen >> Click on the *search* and/or *details* button >> *Available report – details* screen >> Click on the *details* button

#### Privileges

To use this screen, you need the following privilege [[▶ 871](#)]:

Report details query

#### References

##### User Instructions Part

This screen is part of the following business scenario:

View available reports

##### Business Functionality Document

This screen corresponds to the following business function:

Display generated report details (T2S.GUI.INSE.RPT.0090)

## Screenshot

Services > Additional Services > Reports > Report Details > Statement of pending amendment instructions for Intra-Position

**General Information**

**General Statement Information**

Report  
Statement of pending amendment instructions for Intra-Position Movements and Settlement Instructions

|  |  |                                 |
|--|--|---------------------------------|
| Delta Mode<br>Yes                          | Statement Number<br>20160628RD000326     | Report Number<br>1000003891     |
| Frequency<br>DAIL                          | Scheduled<br>C1R1                        | Activity Indicator<br>False     |
| Covered Period from<br>2016-06-27 11:22:24 | Covered Period to<br>2016-06-27 12:38:43 | Report Owner BIC<br>FITBITX1XXX |
| Report Owner Parent BIC<br>TCSOTCS0XXX     | System Entity Wide Report<br>Yes         |                                 |

Cancel

Illustration 103: Available report – statement of pending amendment instructions for intra-position movements and settlement instructions – details screen

**Field Description**

| General Statement Information |   |
|-------------------------------|---|
| Report Name                   | Shows the name of the report.   |
| Delta Mode                    | Shows if the report is a delta report or not. Possible values are:<br><input type="checkbox"/> Yes<br><input type="checkbox"/> No   |
| Statement Number              | Shows the statement number of the report composed of the business date and report type (2-letter abbreviation depending on report type and Delta/Full-Flag) and the sequential number, which is unique in T2S.<br>The number increases for each report. |
| Report Number                 | Shows the sequential number of the report which is specific for a report receiving party.<br>This number will only be displayed if the sending user belongs to a report receiving party.  |
| Scheduled                     | Shows the name of the business event or time triggering the report creation.  |
| Frequency                     | Shows the frequency of the report, which is always 'DAILY'.   |
| Activity Indicator            | Shows whether the report displays activities or only lists information from the possible values:<br><input type="checkbox"/> True<br><input type="checkbox"/> False   |

| General Statement Information  |   |
|--|---|
| Covered Period from  | Shows the date and time from which the data are covered in the report.<br>Displayed format is: YYYY-MM-DD hh:mm:ss  |
| Covered Period to  | Shows the date and time until which the data are covered in the report.<br>Displayed format is: YYYY-MM-DD hh:mm:ss   |
| Report Owner BIC   | Shows the BIC of the party whose data are reported.   |
| Report Owner Parent BIC  | Shows the parent BIC of the party whose data are reported.  |
| System Entity Wide Report  | Shows whether the report is a community report (covering all information referring to a system entity) or a party based report (covering all information referring to a party) from the possible values:<br><br><input type="checkbox"/> Yes<br><input type="checkbox"/> No |
| Amendment Instruction or Hold/Release Instruction<br>Repetitive block for each amendment or hold/release instruction |   |
| Securities Account Information   |   |
| Securities Account Number  | Shows the number of the securities account on which the report is based.  |
| Securities Account Owner BIC   | Shows the BIC of the party owning the securities account.   |
| Securities Account Owner Parent BIC  | Shows the parent BIC of the party owning the securities account.  |
| Status Information   |   |
| Execution Status   | Shows the execution status of the instruction from the possible values:<br><br><input type="checkbox"/> EXCD (for executed)<br><input type="checkbox"/> NEXD (for not executed)   |
| Instruction Status   | Shows the status of the instruction from the possible values:<br><br><input type="checkbox"/> DEND (for denied)<br><input type="checkbox"/> NDEN (for not denied)   |
| Last Update of Status  | Shows the date and time of the last status update.<br>Displayed format is: YYYY-MM-DD hh:mm:ss  |



| <b>General Statement Information</b>  |   |
|---|---|
| <b>Instruction Information for Hold/Release Instruction</b>                       |   |
| <b>This subframe is optional and only available for hold/release instructions</b> |   |
| Inbound Individual Message Identification   | Shows the identification of the inbound message.  |
| Hold/Release Instruction Technical Identifier                                     | Shows the unique identification of the hold/release instruction assigned by T2S.  |
| Hold Status Type  | Shows the status of the hold type from the possible values: <ul style="list-style-type: none"> <li><input type="checkbox"/> CoSD Hold</li> <li><input type="checkbox"/> CSD Hold</li> <li><input type="checkbox"/> CSD Validation Hold</li> <li><input type="checkbox"/> Party Hold</li> </ul>                                  |
| On Hold Indicator   | Shows whether the instruction is on hold from the possible values: <ul style="list-style-type: none"> <li><input type="checkbox"/> YES</li> <li><input type="checkbox"/> NO</li> </ul>  |
| CoSD Rule Identification  | Shows the identification of the respective CoSD rule.   |
| <b>Instruction Information for Amendment Instructions</b>                         |   |
| <b>This subframe is optional and only available for amendment instructions</b>    |   |
| Amendment Instruction Technical Identifier  | Shows the unique identification of the amendment instruction assigned by T2S.   |
| Priority  | Shows the priority of the payment instruction assigned by the originator of the instruction from the possible values: <ul style="list-style-type: none"> <li><input type="checkbox"/> High</li> <li><input type="checkbox"/> Normal</li> <li><input type="checkbox"/> Reserved</li> <li><input type="checkbox"/> Top</li> </ul> |
| Partial Settlement Indicator  | Shows if the settlement instruction is allowed to be subject to partial settlement from the possible values: <ul style="list-style-type: none"> <li><input type="checkbox"/> NPAR (for no partial settlement allowed)</li> </ul>  |

| General Statement Information   |   |
|---|---|
|   | <input type="checkbox"/> PART (for partial settlement allowed without restrictions)<br><input type="checkbox"/> PARC (for partial settlement allowed but the settlement amount must not be below the threshold)<br><input type="checkbox"/> PARQ (for partial settlement allowed but the quantity must not be below the threshold)  |
| Instruction Information for amendment instructions - Linkage Information                    |   |
| This subframe is optional and only available for amendment instructions                     |   |
| Linkage Type of Instruction   | Shows the linkage type of the instruction from the possible values:<br><input type="checkbox"/> LINK (for linked)<br><input type="checkbox"/> UNLK (for unlinked)   |
| Instruction Information for amendment instructions - Linkage Information – Instruction Link |   |
| This subframe is optional and only available for amendment instructions                     |   |
| Link Type   | Shows the link type of the instruction from the possible values:<br><input type="checkbox"/> AFTE (Instruction has to be settled after or at the same time as the linked instruction)<br><input type="checkbox"/> BEFO (Instruction has to be settled before or at the same time as the linked instruction)<br><input type="checkbox"/> WITH (Instruction has to be settled at the same time as the linked instruction) |
| Linked Instruction T2S Technical Identifier   | Shows the identification of the linked instruction assigned by T2S.   |
| Linked Instruction Reference of Party   | Shows the T2S actor reference of the LCMM instruction with which the relevant LCMM instruction is linked.<br>If there is more than 1 link between LCMM instructions, the settlement link indicator is shown.  |
| Received Account Owner BIC  | Shows the BIC of the party who owns the identification of the instruction/pool to which this instruction is linked.   |
| System Entity Reference Owner   | Shows the identification of the system entity of the T2S party owner.   |
| Message Number  | Shows the identification of the message referenced in the linkage sequence.   |

| General Statement Information  |  |
|--|--|
| Pool Instruction Reference   | Shows the identification of the pool groups.   |
| <b>Intra-Position Movement Information</b><br>This subframe is optional and only available for intra-position movement information |  |
| ISIN   | Shows the ISIN of the security.  |
| Original Settlement Quantity   | Shows the quantity of securities to be settled.  |
| Settlement Type  | Shows the type of settlement from the possible values:<br><input type="checkbox"/> UNIT (Units)<br><input type="checkbox"/> FAMT (Face amount)   |
| Intended Settlement Date   | Shows the date when the instruction is forwarded to settlement for the first time.<br><br>Displayed format is: YYYY-MM-DD  |
| Restriction Type Balance From  | Shows a restriction type code of the position of a securities account which is debited.  |
| Restriction Type Balance To  | Shows a restriction type code of the position of a securities account which is credited.   |
| Restriction Reference  | Shows the identification of the restriction assigned by T2S.   |
| Priority   | Shows the priority of the payment instruction assigned by the originator of the instruction from the possible values:<br><input type="checkbox"/> High<br><input type="checkbox"/> Normal<br><input type="checkbox"/> Reserved<br><input type="checkbox"/> Top |
| Intra-Position Movement Technical Identifier   | Shows the unique technical identification of the intra-position movement assigned by T2S.  |
| Account Owner Reference  | Shows the identification of the instruction assigned by the delivering/receiving party.  |
| Account Servicer Reference   | Shows the identification of the transaction assigned by the CSD.   |
| Third Party Reference  | Shows the identification of the instruction assigned by a third party.   |

| General Statement Information  |   |
|--|---|
| <b>Settlement Instruction Information</b>  |   |
| <b>This subframe is optional and only available for settlement instruction information</b> |   |
| Settlement Instruction Technical Identifier  | Shows the unique identification of the settlement instruction assigned by T2S.  |
| Account Owner Reference  | Shows the identification of the settlement instruction assigned by the delivering/receiving party.  |
| Account Servicer Reference   | Shows the identification of the settlement instruction assigned by the CSD.   |
| Third Party Reference  | Shows the identification of the settlement instruction assigned by the third party.   |
| ISIN   | Shows the ISIN of the security.   |
| Original Settlement Quantity   | Shows the quantity of securities to be settled.   |
| Settlement Type  | Shows the type of settlement from the possible values:<br><input type="checkbox"/> UNIT (Units)<br><input type="checkbox"/> FAMT (Face amount)                    |
| Original Settlement Amount   | Shows the amount as stated in the settlement instruction.   |
| Settlement Currency  | Shows the unique code of the currency.  |
| Debit Credit Indicator   | Shows if an operation is a credit or a debit from the possible values:<br><input type="checkbox"/> CRDT (for credit)<br><input type="checkbox"/> DBIT (for debit) |
| Intended Settlement Date   | Shows the date when the instruction is forwarded to settlement for the first time.<br>Displayed format is: YYYY-MM-DD   |
| Trade Date   | Shows the date when the contract was made.<br>Displayed format is: YYYY-MM-DD   |
| <b>Settlement Parties</b>  |   |
| <b>This subframe is optional and only available for settlement instruction information</b> |   |
| <b>Delivering Settlement Parties</b>   |   |
| <b>Delivering Depository</b>   |   |

| <b>General Statement Information</b>   |  |
|--|--|
| Party BIC  | Shows the BIC of the delivering depository.  |
| <b>Delivering CSD Participant</b>  |  |
| Party BIC  | Shows the BIC of the CSD participant delivering the securities.                              |
| Processing Identification  | Shows the unambiguous identification of the transaction as assigned by the delivering party. |
| <b>Client of the Delivering CSD Participant</b>  |  |
| <b>Specifying the party only via party BIC or its name or the triplet of identification, issuer and scheme name.</b> |  |
| Party BIC  | Shows the BIC of the client of delivering CSD participant.                                   |
| Identification   | Shows the proprietary identification of the pre-mentioned party BIC.                         |
| Issuer   | Shows the entity assigning the identification.   |
| Scheme Name  | Shows the name of the scheme.  |
| Name   | Shows the name of the client of delivering CSD participant.                                  |
| <b>Delivering Party 3</b>  |  |
| <b>Specifying the party only via party BIC or its name or the triplet of identification, issuer and scheme name.</b> |  |
| Party BIC  | Shows the BIC of delivering party 3.   |
| Identification   | Shows the proprietary identification of the pre-mentioned party BIC.                         |
| Issuer   | Shows the entity assigning the identification.   |
| Scheme Name  | Shows the name of the scheme.  |
| Name   | Shows the BIC of delivering party 3.   |
| <b>Delivering Party 4</b>  |  |
| <b>Specifying the party only via party BIC or its name or the triplet of identification, issuer and scheme name.</b> |  |
| Party BIC  | Shows the BIC of delivering party 4.   |
| Identification   | Shows the proprietary identification of the pre-mentioned party BIC.                         |
| Issuer   | Shows the entity assigning the identification.   |
| Scheme Name  | Shows the name of the scheme.  |
| Name   | Shows the name of delivering party 4.  |

| <b>General Statement Information</b>   |   |
|--|---|
| <b>Delivering Party 5</b>  |   |
| <b>Specifying the party only via party BIC or its name or the triplet of identification, issuer and scheme name.</b> |   |
| Party BIC  | Shows the BIC of delivering party 5.  |
| Identification   | Shows the proprietary identification of the pre-mentioned party BIC.                        |
| Issuer   | Shows the entity assigning the identification. The fixed value is 'T2S'.                    |
| Scheme Name  | Shows the name of the scheme.   |
| Name   | Shows the name of delivering party 5.   |
| Receiving Settlement Parties   |   |
| <b>Receiving Depository</b>  |   |
| Party BIC  | Shows the BIC of the receiving depository.  |
| <b>Receiving CSD Participant</b>   |   |
| Party BIC  | Shows the BIC of the CSD receiving the securities.  |
| Processing Identification  | Shows the unambiguous identification of the transaction as assigned by the receiving party. |
| <b>Client of the Receiving CSD Participant</b>   |   |
| <b>Specifying the party only via party BIC or its name or the triplet of identification, issuer and scheme name.</b> |   |
| Party BIC  | Shows the BIC of the client of receiving CSD participant.                                   |
| Identification   | Shows the proprietary identification of the pre-mentioned party BIC.                        |
| Issuer   | Shows the entity assigning the identification.  |
| Scheme Name  | Shows the name of the scheme.   |
| Name   | Shows the name of the client of receiving CSD participant.                                  |
| <b>Receiving Party 3</b>   |   |
| <b>Specifying the party only via party BIC or its name or the triplet of identification, issuer and scheme name.</b> |   |
| Party BIC  | Shows the BIC of receiving party 3.   |
| Identification   | Shows the proprietary identification of the pre-mentioned party BIC.                        |
| Issuer   | Shows the entity assigning the identification.  |
| Scheme Name  | Shows the name of the scheme.   |

| General Statement Information  |  |
|--|--|
| Name   | Shows the Name of receiving party 3.                                 |
| <b>Receiving Party 4</b>   |  |
| <b>Specifying the party only via party BIC or its name or the triplet of identification, issuer and scheme name.</b> |  |
| Party BIC  | Shows the BIC of receiving party 4.                                  |
| Identification   | Shows the proprietary identification of the pre-mentioned party BIC. |
| Issuer   | Shows the entity assigning the identification.                       |
| Scheme Name  | Shows the name of the scheme.  |
| Name   | Shows the Name of receiving party 4.                                 |
| <b>Receiving Party 5</b>   |  |
| <b>Specifying the party only via party BIC or its name or the triplet of identification, issuer and scheme name.</b> |  |
| Party BIC  | Shows the BIC of receiving party 5.                                  |
| Identification   | Shows the proprietary identification of the pre-mentioned party BIC. |
| Issuer   | Shows the entity assigning the identification.                       |
| Scheme Name  | Shows the name of the scheme.  |
| Name   | Shows the Name of receiving party 5.                                 |
| Status Information   |  |
| Repetitive Block For Each Hold/Release Instruction Or Amendment Instruction  |  |
| Cancellation Status Reason Code  | Shows the reason code of the cancellation status.                    |

## 2.4.1.12 Available Report - Statement of Pending Cancellation Instructions for Intra-Balance Movements - Details Screen

### Context of Usage

This screen displays detailed information on the selected statement of pending cancellation instructions for intra-balance movements. The report displayed in this screen has to be already created in accordance with its report configuration.

This screen is not relevant for CSD, external CSD and CSD participant users.

### Screen Access

Services >> Additional Services >> Reports >> *Available reports – search/list* screen >> Click on the *details* button

- Services >> Additional Services >> Reports >> **Available reports – search/list** screen >> Click on the **search** and/or **details** button >> **Available report – details** screen >> Click on the **details** button

**Privileges** To use this screen, you need the following privilege [**▶ 871**]:

- Report details query

**References** **User Instructions Part**

This screen is part of the following business scenario:

- View available reports

### Business Functionality Document

This screen corresponds to the following business function:

- Display generated report details (T2S.GUI.INSE.RPT.0090)

**Screenshot**

*Illustration 104: Available report – statement of pending cancellation instruction for intra-balance movements – details screen*

**Field Description**

| General Statement Information |   |
|-------------------------------|---|
| Report Name                   | Shows the name of the report.   |
| Delta Mode                    | Shows if the report is a delta report or not. Possible values are:<br><input type="checkbox"/> Yes<br><input type="checkbox"/> No |
| Statement Number              | Shows the sequential number of the report assigned by the account servicer.<br>The number increases for each report.              |
| Report Number                 | Shows the sequential number of the report which is specific for a report receiving party.   |



| General Statement Information  |   |
|--|---|
|  | This number will only be displayed if the sending user belongs to a report receiving party.   |
| Frequency  | Shows the frequency of the report, which is always 'DAILY'.   |
| Scheduled  | Shows the name of the business event or time triggering the report creation.  |
| Activity Indicator   | Shows whether the report displays activities or only lists information from the possible values:<br><input type="checkbox"/> True<br><input type="checkbox"/> False   |
| Covered Period from  | Shows the date and time from which the data are covered in the report.<br>Displayed format is: YYYY-MM-DD hh:mm:ss  |
| Covered Period to  | Shows the date and time until which the data are covered in the report.<br>Displayed format is: YYYY-MM-DD hh:mm:ss   |
| Report Owner BIC   | Shows the BIC of the party whose data are reported.   |
| Report Owner Parent BIC  | Shows the parent BIC of the party whose data are reported.  |
| System Entity Wide Report  | Shows whether the report is a community report (covering all information referring to a system entity) or a party based report (covering all information referring to a party).<br>from the possible values:<br><input type="checkbox"/> Yes<br><input type="checkbox"/> No |
| T2S Dedicated Cash Account Information   |   |
| Repetitive Block For Each Cancellation Instruction For Intra-Balance Movements |   |
| T2S Dedicated Cash Account Owner BIC   | Shows the BIC of the party owning the T2S dedicated cash account owner.   |
| T2S Dedicated Cash Account Owner Parent BIC                                    | Shows the parent BIC of the party owning the dedicated cash account.  |
| T2S Dedicated Cash Account Number  | Shows the T2S dedicated cash account for which the report is created.   |

| General Statement Information  |   |
|--|---|
| Cancellation Status  | Shows the status of the instruction from the possible values:<br><input type="checkbox"/> DEND (for denied)<br><input type="checkbox"/> NDEN (for not denied)               |
| Reason Code  | Shows code of the reason why the instruction has a certain settlement status according to ISO20022.   |
| Reason Code Description  | Shows the detailed description of the reason code.  |
| Execution Status   | Shows the execution status of the instruction from the possible values:<br><input type="checkbox"/> EXCD (for executed)<br><input type="checkbox"/> NEXD (for not executed) |
| Reason Code  | Shows the code of the reason why the instruction has a certain settlement status according to ISO20022.   |
| Reason Code Description  | Shows the detailed description of the reason code.  |
| Request Reference  | Shows the Inbound LCMM Message Reference  |
| Last Update of Status  | Shows the date and time of the last status update.<br>Displayed format is: YYYY-MM-DD hh:mm:ss  |
| Referenced Instruction   |   |
| Repetitive Block For Each Cancellation Instruction For Intra-Balance Movements |   |
| References   |   |
| Account Owner Reference  | Shows the identification of the instruction assigned by the T2S delivering/receiving party.   |
| Account Servicer Reference   | Shows the identification of the instruction assigned by the account servicer.   |
| Third Party Reference  | Shows the identification of the instruction assigned by a third party.  |
| Intra-Balance Movement Reference   | Shows the unique identification of the intra-balance movement assigned by T2S.  |
| Instruction Details  |   |
| Intended Settlement Date   | Shows the date when the instruction is forwarded to settlement for the first time.<br>Displayed format is: YYYY-MM-DD   |

| General Statement Information |  |
|-------------------------------|--|
| Priority                      | Shows the priority of the payment instruction assigned by the originator of the instruction from the possible values:<br><input type="checkbox"/> High<br><input type="checkbox"/> Normal<br><input type="checkbox"/> Reserved<br><input type="checkbox"/> Top |
| Settlement Amount             | Shows the amount as stated in the settlement instruction.  |
| Currency                      | Shows the currency code.   |
| Restriction Reference         | Shows the identification of the restriction assigned by T2S.   |
| Balance from Type             | Shows a code to identify the restriction.  |
| Issuer                        | Shows the entity that assigns the identification.  |
| Scheme Name                   | Shows the description of the scheme.   |
| Balance to Type               | Shows a code to identify the restriction.  |
| Issuer                        | Shows the entity that assigns the identification.  |
| Scheme Name                   | Shows the description of the scheme.   |

### 2.4.1.13 Available Report - Statement of Pending Cancellation Instructions for Intra-Position Movements and Settlement Instructions - Details Screen

|                         |   |
|-------------------------|---|
| <b>Context of Usage</b> | This screen displays detailed information on pending cancellation instructions for intra-position movements and settlement instructions. The report displayed in this screen has to be already created in accordance with its report configuration.<br><br>This screen is not relevant for CB and payment bank/settlement bank users.   |
| <b>Screen Access</b>    | <ul style="list-style-type: none"> <li><input type="checkbox"/> Services &gt;&gt; Additional Services &gt;&gt; Reports &gt;&gt; <i>Available reports – search/list</i> screen &gt;&gt; Click on the <i>details</i> button</li> <li><input type="checkbox"/> Services &gt;&gt; Additional Services &gt;&gt; Reports &gt;&gt; <i>Available reports – search/list</i> screen &gt;&gt; Click on the <i>search</i> and/or <i>details</i> button &gt;&gt; <i>Available report – details</i> screen &gt;&gt; Click on the <i>details</i> button</li> </ul> |
| <b>Privileges</b>       | To use this screen, you need the following privilege [ <a href="#">▶ 872</a> ]:<br><br><input type="checkbox"/> Report details query  |
| <b>References</b>       | <b>User Instructions Part</b><br><br>This screen is part of the following business scenario:<br><br><input type="checkbox"/> View available reports   |

**Business Functionality Document**

This screen corresponds to the following business function:

- Display generated report details (T2S.GUI.RPT.0090)

**Screenshot**

*Illustration 105: Available report – statement of pending cancellation instructions for intra-position movements and settlement instruction – details screen*

**Field Description**

| General Statement Information |   |
|-------------------------------|---|
| Report Name                   | Shows the name of the report.   |
| Delta Mode                    | Shows if the report is a delta report or not. Possible values are:<br><input type="checkbox"/> Yes<br><input type="checkbox"/> No   |
| Statement Number              | Shows the statement number of the report composed of the business date and report type (2-letter abbreviation depending on report type and delta/full-flag) and the sequential number, which is unique in T2S.<br><br>The number increases for each report. |
| Report Number                 | Shows the sequential number of the report which is specific for a report receiving party.<br><br>This number will only be displayed if the sending user belongs to a report receiving party.  |
| Scheduled                     | Shows the name of the business event or time triggering the report creation.  |
| Frequency                     | Shows the frequency of the report from the possible value:<br><input type="checkbox"/> DAILY (for reports created on a daily basis)   |

| General Statement Information                     |   |
|---|---|
| Activity Indicator                                | Shows whether the report displays activities or only lists information from the possible values:<br><br><input type="checkbox"/> True<br><input type="checkbox"/> False   |
| Covered Period from                               | Shows the date and time from which the data are covered in the report.<br><br>Displayed format is: YYYY-MM-DD hh:mm:ss  |
| Covered Period to                                 | Shows the date and time until which the data are covered in the report.<br><br>Displayed format is: YYYY-MM-DD hh:mm:ss   |
| Report Owner BIC                                  | Shows the BIC of the party whose data are reported.   |
| Report Owner Parent BIC                           | Shows the parent BIC of the party whose data are reported.  |
| System Entity Wide Report                         | Shows whether the report is a community report (covering all information referring to a system entity) or a party based report (covering all information referring to a party) from the possible values:<br><br><input type="checkbox"/> Yes<br><input type="checkbox"/> No |
| Cancellation Instruction Information              |   |
| Actor Reference                                   | Shows the reference assigned for a cancellation instruction by the T2S actor.   |
| Securities Account Information                    |   |
| Securities Account Number                         | Shows the number of the securities account.   |
| Securities Account Owner BIC                      | Shows the BIC of the securities account.  |
| Securities Account Servicer BIC                   | Shows the BIC of the party operating the securities account.  |
| Processing Status of the Cancellation Instruction |   |
| Execution Status                                  | Shows the execution status of the instruction from the possible values:<br><br><input type="checkbox"/> EXCD (for executed)<br><input type="checkbox"/> NEXD (for not executed)   |

| General Statement Information              |   |
|--|---|
| Execution Status Reason Code               | Shows the ISO 20022 reason code why the related instruction is cancelled or the related cancellation request is executed.   |
| Execution Status Additional Information    | Shows additional information about the execution status.  |
| Cancellation Status                        | Shows the status of the instruction from the possible values:<br><input type="checkbox"/> DEND (for denied)<br><input type="checkbox"/> NDEN (for not denied)         |
| Cancellation Status Reason Code            | Shows the reason code for the cancellation.   |
| Cancellation Status Additional Information | Shows additional information on the cancellation status.  |
| Acknowledged Accepted                      | Shows whether the instruction passed all business validations within T2S from the possible values:<br><input type="checkbox"/> True<br><input type="checkbox"/> False |
| Pending Cancellation                       | Shows whether the cancellation instruction is pending from the possible values:<br><input type="checkbox"/> True<br><input type="checkbox"/> False                    |
| Pending Cancellation Reason Code           | Shows the reason code why the cancellation instruction is pending.  |
| Last Update of Status                      | Shows the date and time of the last status update.<br>Displayed format is: YYYY-MM-DD hh:mm:ss  |
| References of Underlying Instruction       |   |
| Account Owner Reference                    | Shows the reference of an instruction which is assigned by the T2S delivering/receiving party.  |
| Account Servicer Reference                 | Shows the identification of the transaction assigned by the CSD.  |
| Third Party Reference                      | Shows the identification of the instruction assigned by a third party.  |

| General Statement Information            |   |
|--|---|
| T2S Reference                            | Shows the identification of the instruction assigned by T2S.  |
| Underlying Instruction Information       |   |
| Instruction Type                         | Shows the type of instruction from the possible values: <ul style="list-style-type: none"> <li><input type="checkbox"/> SI (for settlement instruction)</li> <li><input type="checkbox"/> SR (for settlement restriction)</li> </ul>  |
| ISIN                                     | Shows the ISIN of the security.   |
| Intended Settlement Date                 | Shows the date when the instruction is forwarded to settlement for the first time.<br>Displayed format is: YYYY-MM-DD   |
| Trade Date                               | Shows the date when the contract was made.<br>Displayed format is: YYYY-MM-DD   |
| Original Settlement Unit                 | Shows the number of securities which shall be settled.  |
| Original Settlement Quantity Face Amount | Shows the face amount of securities which shall be settled.   |
| Original Settlement Amount               | Shows the amount as stated in the settlement instruction.   |
| Currency                                 | Shows the currency code.  |
| Debit Credit Indicator                   | Shows if an operation is a credit or a debit from the possible values: <ul style="list-style-type: none"> <li><input type="checkbox"/> CRDT (for credit)</li> <li><input type="checkbox"/> DBIT (for debit)</li> </ul>  |
| Priority                                 | Shows the priority of the payment instruction assigned by the originator of the instruction from the possible values: <ul style="list-style-type: none"> <li><input type="checkbox"/> High</li> <li><input type="checkbox"/> Normal</li> <li><input type="checkbox"/> Reserved</li> <li><input type="checkbox"/> Top</li> </ul> |
| Restriction Reference                    | Shows the identification of the restriction assigned by T2S.  |
| Restriction Type Balance from            | Shows the restriction type code of a balance of a T2S DCA/position of a debited securities account. The code is defined by a CSD or the CB to identify the restriction.   |

| <b>General Statement Information</b>   |  |
|--|--|
| Issuer   | Shows the entity assigning the identification. The fixed value is 'T2S'.   |
| Scheme Name  | Shows the name of the scheme.  |
| Restriction Type Balance to  | Shows the restriction type code of a balance of a T2S DCA/position of a credited securities account. The code is defined by a CSD or the CB to identify the restriction. |
| Issuer   | Shows the entity assigning the identification. The fixed value is 'T2S'.   |
| Scheme Name  | Shows the name of the scheme.  |
| <b>Settlement Parties</b>  |  |
| <b>Delivering Settlement Parties</b>   |  |
| This subframe is optional and only available for settlement instruction information                                  |  |
| <b>Delivering Depository</b>   |  |
| Party BIC  | Shows the BIC of the delivering depository.  |
| <b>Delivering CSD Participant</b>  |  |
| Party BIC  | Shows the BIC of the CSD participant delivering the securities.  |
| Processing Identification  | Shows the unambiguous identification of the transaction as assigned by the delivering party.   |
| <b>Client of the Delivering CSD Participant</b>  |  |
| <b>Specifying the party only via party BIC or its name or the triplet of identification, issuer and scheme name.</b> |  |
| Party BIC  | Shows the BIC of the client of delivering CSD participant.   |
| Identification   | Shows the proprietary identification of the pre-mentioned party BIC.   |
| Issuer   | Shows the entity assigning the identification.   |
| Scheme Name  | Shows the name of the scheme.  |
| Name   | Shows the name of the client of delivering CSD participant.  |
| <b>Delivering Party 3</b>  |  |
| <b>Specifying the party only via party BIC or its name or the triplet of identification, issuer and scheme name.</b> |  |
| Party BIC  | Shows the BIC of delivering party 3.   |



| <b>General Statement Information</b>   |   |
|--|---|
| Identification   | Shows the proprietary identification of the pre-mentioned party BIC.                        |
| Issuer   | Shows the entity assigning the identification.  |
| Scheme Name  | Shows the name of the scheme.   |
| Name   | Shows the name of delivering party 3.   |
| <b>Delivering Party 4</b>  |   |
| <b>Specifying the party only via party BIC or its name or the triplet of identification, issuer and scheme name.</b> |   |
| Party BIC  | Shows the BIC of delivering party 4.  |
| Identification   | Shows the proprietary identification of the pre-mentioned party BIC.                        |
| Issuer   | Shows the entity assigning the identification.  |
| Scheme Name  | Shows the name of the scheme.   |
| Name   | Shows the name of delivering party 4.   |
| <b>Delivering Party 5</b>  |   |
| <b>Specifying the party only via party BIC or its name or the triplet of identification, issuer and scheme name.</b> |   |
| Party BIC  | Shows the BIC of delivering party 5.  |
| Identification   | Shows the proprietary identification of the pre-mentioned party BIC.                        |
| Issuer   | Shows the entity assigning the identification. The fixed value is 'T2S'.                    |
| Scheme Name  | Shows the name of the scheme.   |
| Name   | Shows the name of delivering party 5.   |
| <b>Receiving Settlement Parties</b>  |   |
| This subframe is optional and only available for settlement instruction information                                  |   |
| <b>Receiving Depository</b>  |   |
| Party BIC  | Shows the BIC of the receiving depository.  |
| <b>Receiving CSD Participant</b>   |   |
| Party BIC  | Shows the BIC of the CSD receiving the securities.  |
| Processing Identification  | Shows the unambiguous identification of the transaction as assigned by the receiving party. |
| <b>Client of the Receiving CSD Participant</b>   |   |

| General Statement Information  |  |
|--|--|
| <b>Specifying the party only via party BIC or its name or the triplet of identification, issuer and scheme name.</b> |  |
| Party BIC  | Shows the BIC of the client of receiving CSD participant.            |
| Identification   | Shows the proprietary identification of the pre-mentioned party BIC. |
| Issuer   | Shows the entity assigning the identification.                       |
| Scheme Name  | Shows the name of the scheme.  |
| Name   | Shows the name of the client of receiving CSD participant.           |
| <b>Receiving Party 3</b>   |  |
| <b>Specifying the party only via party BIC or its name or the triplet of identification, issuer and scheme name.</b> |  |
| Party BIC  | Shows the BIC of receiving party 3.                                  |
| Identification   | Shows the proprietary identification of the pre-mentioned party BIC. |
| Issuer   | Shows the entity assigning the identification.                       |
| Scheme Name  | Shows the name of the scheme.  |
| Name   | Shows the Name of receiving party 3.                                 |
| <b>Receiving Party 4</b>   |  |
| <b>Specifying the party only via party BIC or its name or the triplet of identification, issuer and scheme name.</b> |  |
| Party BIC  | Shows the BIC of receiving party 4.                                  |
| Identification   | Shows the proprietary identification of the pre-mentioned party BIC. |
| Issuer   | Shows the entity assigning the identification.                       |
| Scheme Name  | Shows the name of the scheme.  |
| Name   | Shows the Name of receiving party 4.                                 |
| <b>Receiving Party 5</b>   |  |
| <b>Specifying the party only via party BIC or its name or the triplet of identification, issuer and scheme name.</b> |  |
| Party BIC  | Shows the BIC of receiving party 5.                                  |
| Identification   | Shows the proprietary identification of the pre-mentioned party BIC. |
| Issuer   | Shows the entity assigning the identification.                       |
| Scheme Name  | Shows the name of the scheme.  |

| General Statement Information |                                      |
|-------------------------------|--------------------------------------|
| Name                          | Shows the Name of receiving party 5. |

## 2.4.1.14 Available Report - Statement of Pending Instructions - Details Screen

### Context of Usage

This screen displays detailed information on pending instructions.

The report displayed in this screen has to be already created in accordance with its report configuration.

For large reports the user has the option view them in portions of up to 500 transactions. Only the current portion of the report will be available for a download or print.

This screen is not relevant for CB and payment bank/settlement bank users.

### Screen Access

Services >> Additional Services >> Reports >> *Available reports – search/list* screen >> Click on the *details* button

Services >> Additional Services >> Reports >> *Available reports – search/list* screen >> Click on the *search* and/or *details* button >> *Available report – details* screen >> Click on the *details* button

### Privileges

To use this screen, you need the following privilege [[▶ 872](#)]:

Report details query

### References

#### User Instructions Part

This screen is part of the following business scenario:

View available reports

#### Business Functionality Document

This screen corresponds to the following business function:

Display generated report details (T2S.GUI.INSE.RPT.0090)

Screenshot

| SECURITIES   | CASH   | SERVICES  | STATIC DATA | MONITORING |  |                                      |                                      |   |                                   |                         |                            |  |  |                                 |  |                                     |   |   |  |                               |                            |  |                           |                                   |  |  |   |                          |                                   |     |                               |     |                                  |                                     |   |                                  |                                   |               |                    |                         |     |                                  |                              |     |                                  |                                    |  |                                  |                                   |               |                    |                         |     |                                  |                              |   |                                     |  |                          |                           |                                 |                                 |                            |                          |     |     |                          |  |                                |                                  |                     |   |                              |                               |                                      |                                    |                    |   |
|--|--|---|-------------|------------|--|--------------------------------------|--------------------------------------|---|-----------------------------------|-------------------------|----------------------------|--|--|---------------------------------|--|-------------------------------------|---|---|--|-------------------------------|----------------------------|--|---------------------------|-----------------------------------|--|--|---|--------------------------|-----------------------------------|-----|-------------------------------|-----|----------------------------------|-------------------------------------|---|----------------------------------|-----------------------------------|---------------|--------------------|-------------------------|-----|----------------------------------|------------------------------|-----|----------------------------------|------------------------------------|--|----------------------------------|-----------------------------------|---------------|--------------------|-------------------------|-----|----------------------------------|------------------------------|---|-------------------------------------|--|--------------------------|---------------------------|---------------------------------|---------------------------------|----------------------------|--------------------------|-----|-----|--------------------------|--|--------------------------------|----------------------------------|---------------------|---|------------------------------|-------------------------------|--------------------------------------|------------------------------------|--------------------|---|
| <p>Services &gt; Additional Services &gt; Reports &gt; Report Details &gt; Statement of Pending Instructions</p>   |  |   |             |            |  |                                      |                                      |   |                                   |                         |                            |  |  |                                 |  |                                     |   |   |  |                               |                            |  |                           |                                   |  |  |   |                          |                                   |     |                               |     |                                  |                                     |   |                                  |                                   |               |                    |                         |     |                                  |                              |     |                                  |                                    |  |                                  |                                   |               |                    |                         |     |                                  |                              |   |                                     |  |                          |                           |                                 |                                 |                            |                          |     |     |                          |  |                                |                                  |                     |   |                              |                               |                                      |                                    |                    |   |
| <p><b>General Information</b></p> <p>General Statement Information</p> <table border="1"> <tr> <td>Report Name<br/>Statement of Pending Instructions</td> <td>Delta Mode<br/>No</td> <td>Statement Number<br/>20210408PF001157</td> </tr> <tr> <td>Report Number<br/>100002662</td> <td>Frequency<br/>DAIL</td> <td>Scheduled<br/>12.00</td> </tr> <tr> <td>Activity Indicator<br/>True</td> <td>Covered Period from<br/>2021-04-07 11:12:28</td> <td>Covered Period to<br/>2021-04-07 12:00:00</td> </tr> <tr> <td>Report Owner BIC<br/>CSDGNLA0XXX</td> <td>Report Owner Parent BIC<br/>TCSOTCS0XXX</td> <td>System Entity Wide Report<br/>Yes</td> </tr> <tr> <td>Securities Account Number<br/>ISSACGNL0001</td> <td>Securities Account Owner BIC<br/>CSDGNLA0XXX</td> <td>Securities Account Servicer BIC<br/>TCSOTCS0XXX</td> </tr> </table>   |  |   |             |            | Report Name<br>Statement of Pending Instructions | Delta Mode<br>No                     | Statement Number<br>20210408PF001157 | Report Number<br>100002662                                      | Frequency<br>DAIL                 | Scheduled<br>12.00      | Activity Indicator<br>True | Covered Period from<br>2021-04-07 11:12:28 | Covered Period to<br>2021-04-07 12:00:00 | Report Owner BIC<br>CSDGNLA0XXX | Report Owner Parent BIC<br>TCSOTCS0XXX | System Entity Wide Report<br>Yes    | Securities Account Number<br>ISSACGNL0001 | Securities Account Owner BIC<br>CSDGNLA0XXX | Securities Account Servicer BIC<br>TCSOTCS0XXX |                               |                            |  |                           |                                   |  |  |   |                          |                                   |     |                               |     |                                  |                                     |   |                                  |                                   |               |                    |                         |     |                                  |                              |     |                                  |                                    |  |                                  |                                   |               |                    |                         |     |                                  |                              |   |                                     |  |                          |                           |                                 |                                 |                            |                          |     |     |                          |  |                                |                                  |                     |   |                              |                               |                                      |                                    |                    |   |
| Report Name<br>Statement of Pending Instructions   | Delta Mode<br>No                                       | Statement Number<br>20210408PF001157                              |             |            |  |                                      |                                      |   |                                   |                         |                            |  |  |                                 |  |                                     |   |   |  |                               |                            |  |                           |                                   |  |  |   |                          |                                   |     |                               |     |                                  |                                     |   |                                  |                                   |               |                    |                         |     |                                  |                              |     |                                  |                                    |  |                                  |                                   |               |                    |                         |     |                                  |                              |   |                                     |  |                          |                           |                                 |                                 |                            |                          |     |     |                          |  |                                |                                  |                     |   |                              |                               |                                      |                                    |                    |   |
| Report Number<br>100002662   | Frequency<br>DAIL                                      | Scheduled<br>12.00  |             |            |  |                                      |                                      |   |                                   |                         |                            |  |  |                                 |  |                                     |   |   |  |                               |                            |  |                           |                                   |  |  |   |                          |                                   |     |                               |     |                                  |                                     |   |                                  |                                   |               |                    |                         |     |                                  |                              |     |                                  |                                    |  |                                  |                                   |               |                    |                         |     |                                  |                              |   |                                     |  |                          |                           |                                 |                                 |                            |                          |     |     |                          |  |                                |                                  |                     |   |                              |                               |                                      |                                    |                    |   |
| Activity Indicator<br>True   | Covered Period from<br>2021-04-07 11:12:28             | Covered Period to<br>2021-04-07 12:00:00                          |             |            |  |                                      |                                      |   |                                   |                         |                            |  |  |                                 |  |                                     |   |   |  |                               |                            |  |                           |                                   |  |  |   |                          |                                   |     |                               |     |                                  |                                     |   |                                  |                                   |               |                    |                         |     |                                  |                              |     |                                  |                                    |  |                                  |                                   |               |                    |                         |     |                                  |                              |   |                                     |  |                          |                           |                                 |                                 |                            |                          |     |     |                          |  |                                |                                  |                     |   |                              |                               |                                      |                                    |                    |   |
| Report Owner BIC<br>CSDGNLA0XXX  | Report Owner Parent BIC<br>TCSOTCS0XXX                 | System Entity Wide Report<br>Yes                                  |             |            |  |                                      |                                      |   |                                   |                         |                            |  |  |                                 |  |                                     |   |   |  |                               |                            |  |                           |                                   |  |  |   |                          |                                   |     |                               |     |                                  |                                     |   |                                  |                                   |               |                    |                         |     |                                  |                              |     |                                  |                                    |  |                                  |                                   |               |                    |                         |     |                                  |                              |   |                                     |  |                          |                           |                                 |                                 |                            |                          |     |     |                          |  |                                |                                  |                     |   |                              |                               |                                      |                                    |                    |   |
| Securities Account Number<br>ISSACGNL0001  | Securities Account Owner BIC<br>CSDGNLA0XXX            | Securities Account Servicer BIC<br>TCSOTCS0XXX                    |             |            |  |                                      |                                      |   |                                   |                         |                            |  |  |                                 |  |                                     |   |   |  |                               |                            |  |                           |                                   |  |  |   |                          |                                   |     |                               |     |                                  |                                     |   |                                  |                                   |               |                    |                         |     |                                  |                              |     |                                  |                                    |  |                                  |                                   |               |                    |                         |     |                                  |                              |   |                                     |  |                          |                           |                                 |                                 |                            |                          |     |     |                          |  |                                |                                  |                     |   |                              |                               |                                      |                                    |                    |   |
| <p><b>Pending Settlement Instruction 1 of 1</b></p> <p>Instruction References</p> <table border="1"> <tr> <td>Account Owner Reference<br/>NONREF</td> <td>Account Servicer Reference<br/>SI0001</td> <td>Third Party Reference<br/>---</td> </tr> <tr> <td>Settlement Instruction Technical Identifier<br/>2104070502627263</td> <td>Pool Instruction Reference<br/>---</td> <td>Common Reference<br/>---</td> </tr> </table> <p>Trade Timeline</p> <table border="1"> <tr> <td>Trade Date<br/>2021-04-07</td> <td>Intended Settlement Date<br/>2021-04-07</td> </tr> </table> <p>Trade Information</p> <table border="1"> <tr> <td>Movement Type Code<br/>DELI</td> <td>Payment Type<br/>FREE</td> <td>ISIN<br/>NLCGNL000012</td> </tr> <tr> <td>Name<br/>CSDGNLA0XXX as NLCGNL000012</td> <td>Remaining Quantity<br/>100</td> <td>Settlement Type<br/>UNIT</td> </tr> <tr> <td>Remaining Amount<br/>---</td> <td>Credit Debit Indicator<br/>---</td> <td>Settlement Currency<br/>---</td> </tr> <tr> <td>Place of Trade Market Type Proprietary Issuer<br/>---</td> <td>Place of Trade MIC<br/>---</td> <td>Place of Trade Description<br/>---</td> </tr> <tr> <td>Place of Trade Market Type Code<br/>---</td> <td>Place of Trade Market Type Proprietary Id<br/>---</td> <td>Place of Trade Market Type Proprietary Scheme Name<br/>---</td> </tr> <tr> <td>Place of Clearing<br/>---</td> <td>Transaction Activity Code<br/>SETT</td> <td>---</td> </tr> </table> <p>Delivering Settlement Parties</p> <table border="1"> <tr> <td>Delivering CSD<br/>CSDGNLA0XXX</td> <td>---</td> <td>Processing Identification<br/>---</td> </tr> <tr> <td>Delivering T2S Party<br/>CSDGNLA0XXX</td> <td>Delivering Party - Securities Account<br/>ISSACGNL0001</td> <td>Processing Identification<br/>---</td> </tr> <tr> <td>Proprietary Identification<br/>---</td> <td>Issuer<br/>---</td> <td>Schema Name<br/>---</td> </tr> <tr> <td>Name and Address<br/>---</td> <td>---</td> <td>Processing Identification<br/>---</td> </tr> </table> <p>Receiving Settlement Parties</p> <table border="1"> <tr> <td>Receiving CSD<br/>CSDGNLA0XXX</td> <td>---</td> <td>Processing Identification<br/>---</td> </tr> <tr> <td>Receiving T2S Party<br/>PMBGNLA0XXX</td> <td>Receiving Party - Securities Account<br/>CSDPCGNL0002</td> <td>Processing Identification<br/>---</td> </tr> <tr> <td>Proprietary Identification<br/>---</td> <td>Issuer<br/>---</td> <td>Schema Name<br/>---</td> </tr> <tr> <td>Name and Address<br/>---</td> <td>---</td> <td>Processing Identification<br/>---</td> </tr> </table> <p>Further Information</p> <table border="1"> <tr> <td>ISO Transaction Code<br/>TRAD</td> <td>Settlement Transaction Condition Indicator<br/>---</td> <td>Partial Settlement Indicator<br/>---</td> </tr> <tr> <td>Corporate Action Event Identification<br/>---</td> <td>CSD Hold Status<br/>false</td> <td>CoSD Hold Status<br/>false</td> </tr> <tr> <td>CoSD Rule Identification<br/>---</td> <td>Validation Hold Status<br/>false</td> <td>Party Hold Status<br/>false</td> </tr> </table> <p>Status Information</p> <table border="1"> <tr> <td>Matching Status<br/>false</td> <td>---</td> <td>---</td> </tr> <tr> <td>Settlement Status<br/>---</td> <td>Accepted Timestamp (SF1)<br/>2021-04-07T10:28:16.74410Z</td> <td>Matched Timestamp (SF2)<br/>---</td> </tr> <tr> <td>ISO Settlement-Status<br/>Failing</td> <td>Reason Code<br/>CYCL</td> <td>Reason Code Additional Information<br/>AwaitingNextSettlementCycle</td> </tr> <tr> <td>Cancellation Requested<br/>No</td> <td>Acknowledgement Status<br/>---</td> <td>Cancellation Status<br/>Not Cancelled</td> </tr> <tr> <td>Pending Cancellation Status<br/>---</td> <td>Reason Code<br/>---</td> <td>Reason Code Additional Information<br/>---</td> </tr> </table> |  |   |             |            | Account Owner Reference<br>NONREF                | Account Servicer Reference<br>SI0001 | Third Party Reference<br>---         | Settlement Instruction Technical Identifier<br>2104070502627263 | Pool Instruction Reference<br>--- | Common Reference<br>--- | Trade Date<br>2021-04-07   | Intended Settlement Date<br>2021-04-07     | Movement Type Code<br>DELI               | Payment Type<br>FREE            | ISIN<br>NLCGNL000012                   | Name<br>CSDGNLA0XXX as NLCGNL000012 | Remaining Quantity<br>100                 | Settlement Type<br>UNIT                     | Remaining Amount<br>---                        | Credit Debit Indicator<br>--- | Settlement Currency<br>--- | Place of Trade Market Type Proprietary Issuer<br>--- | Place of Trade MIC<br>--- | Place of Trade Description<br>--- | Place of Trade Market Type Code<br>--- | Place of Trade Market Type Proprietary Id<br>--- | Place of Trade Market Type Proprietary Scheme Name<br>--- | Place of Clearing<br>--- | Transaction Activity Code<br>SETT | --- | Delivering CSD<br>CSDGNLA0XXX | --- | Processing Identification<br>--- | Delivering T2S Party<br>CSDGNLA0XXX | Delivering Party - Securities Account<br>ISSACGNL0001 | Processing Identification<br>--- | Proprietary Identification<br>--- | Issuer<br>--- | Schema Name<br>--- | Name and Address<br>--- | --- | Processing Identification<br>--- | Receiving CSD<br>CSDGNLA0XXX | --- | Processing Identification<br>--- | Receiving T2S Party<br>PMBGNLA0XXX | Receiving Party - Securities Account<br>CSDPCGNL0002 | Processing Identification<br>--- | Proprietary Identification<br>--- | Issuer<br>--- | Schema Name<br>--- | Name and Address<br>--- | --- | Processing Identification<br>--- | ISO Transaction Code<br>TRAD | Settlement Transaction Condition Indicator<br>--- | Partial Settlement Indicator<br>--- | Corporate Action Event Identification<br>--- | CSD Hold Status<br>false | CoSD Hold Status<br>false | CoSD Rule Identification<br>--- | Validation Hold Status<br>false | Party Hold Status<br>false | Matching Status<br>false | --- | --- | Settlement Status<br>--- | Accepted Timestamp (SF1)<br>2021-04-07T10:28:16.74410Z | Matched Timestamp (SF2)<br>--- | ISO Settlement-Status<br>Failing | Reason Code<br>CYCL | Reason Code Additional Information<br>AwaitingNextSettlementCycle | Cancellation Requested<br>No | Acknowledgement Status<br>--- | Cancellation Status<br>Not Cancelled | Pending Cancellation Status<br>--- | Reason Code<br>--- | Reason Code Additional Information<br>--- |
| Account Owner Reference<br>NONREF  | Account Servicer Reference<br>SI0001                   | Third Party Reference<br>---                                      |             |            |  |                                      |                                      |   |                                   |                         |                            |  |  |                                 |  |                                     |   |   |  |                               |                            |  |                           |                                   |  |  |   |                          |                                   |     |                               |     |                                  |                                     |   |                                  |                                   |               |                    |                         |     |                                  |                              |     |                                  |                                    |  |                                  |                                   |               |                    |                         |     |                                  |                              |   |                                     |  |                          |                           |                                 |                                 |                            |                          |     |     |                          |  |                                |                                  |                     |   |                              |                               |                                      |                                    |                    |   |
| Settlement Instruction Technical Identifier<br>2104070502627263  | Pool Instruction Reference<br>---                      | Common Reference<br>---   |             |            |  |                                      |                                      |   |                                   |                         |                            |  |  |                                 |  |                                     |   |   |  |                               |                            |  |                           |                                   |  |  |   |                          |                                   |     |                               |     |                                  |                                     |   |                                  |                                   |               |                    |                         |     |                                  |                              |     |                                  |                                    |  |                                  |                                   |               |                    |                         |     |                                  |                              |   |                                     |  |                          |                           |                                 |                                 |                            |                          |     |     |                          |  |                                |                                  |                     |   |                              |                               |                                      |                                    |                    |   |
| Trade Date<br>2021-04-07   | Intended Settlement Date<br>2021-04-07                 |   |             |            |  |                                      |                                      |   |                                   |                         |                            |  |  |                                 |  |                                     |   |   |  |                               |                            |  |                           |                                   |  |  |   |                          |                                   |     |                               |     |                                  |                                     |   |                                  |                                   |               |                    |                         |     |                                  |                              |     |                                  |                                    |  |                                  |                                   |               |                    |                         |     |                                  |                              |   |                                     |  |                          |                           |                                 |                                 |                            |                          |     |     |                          |  |                                |                                  |                     |   |                              |                               |                                      |                                    |                    |   |
| Movement Type Code<br>DELI   | Payment Type<br>FREE                                   | ISIN<br>NLCGNL000012  |             |            |  |                                      |                                      |   |                                   |                         |                            |  |  |                                 |  |                                     |   |   |  |                               |                            |  |                           |                                   |  |  |   |                          |                                   |     |                               |     |                                  |                                     |   |                                  |                                   |               |                    |                         |     |                                  |                              |     |                                  |                                    |  |                                  |                                   |               |                    |                         |     |                                  |                              |   |                                     |  |                          |                           |                                 |                                 |                            |                          |     |     |                          |  |                                |                                  |                     |   |                              |                               |                                      |                                    |                    |   |
| Name<br>CSDGNLA0XXX as NLCGNL000012  | Remaining Quantity<br>100                              | Settlement Type<br>UNIT   |             |            |  |                                      |                                      |   |                                   |                         |                            |  |  |                                 |  |                                     |   |   |  |                               |                            |  |                           |                                   |  |  |   |                          |                                   |     |                               |     |                                  |                                     |   |                                  |                                   |               |                    |                         |     |                                  |                              |     |                                  |                                    |  |                                  |                                   |               |                    |                         |     |                                  |                              |   |                                     |  |                          |                           |                                 |                                 |                            |                          |     |     |                          |  |                                |                                  |                     |   |                              |                               |                                      |                                    |                    |   |
| Remaining Amount<br>---  | Credit Debit Indicator<br>---                          | Settlement Currency<br>---  |             |            |  |                                      |                                      |   |                                   |                         |                            |  |  |                                 |  |                                     |   |   |  |                               |                            |  |                           |                                   |  |  |   |                          |                                   |     |                               |     |                                  |                                     |   |                                  |                                   |               |                    |                         |     |                                  |                              |     |                                  |                                    |  |                                  |                                   |               |                    |                         |     |                                  |                              |   |                                     |  |                          |                           |                                 |                                 |                            |                          |     |     |                          |  |                                |                                  |                     |   |                              |                               |                                      |                                    |                    |   |
| Place of Trade Market Type Proprietary Issuer<br>---   | Place of Trade MIC<br>---                              | Place of Trade Description<br>---                                 |             |            |  |                                      |                                      |   |                                   |                         |                            |  |  |                                 |  |                                     |   |   |  |                               |                            |  |                           |                                   |  |  |   |                          |                                   |     |                               |     |                                  |                                     |   |                                  |                                   |               |                    |                         |     |                                  |                              |     |                                  |                                    |  |                                  |                                   |               |                    |                         |     |                                  |                              |   |                                     |  |                          |                           |                                 |                                 |                            |                          |     |     |                          |  |                                |                                  |                     |   |                              |                               |                                      |                                    |                    |   |
| Place of Trade Market Type Code<br>---   | Place of Trade Market Type Proprietary Id<br>---       | Place of Trade Market Type Proprietary Scheme Name<br>---         |             |            |  |                                      |                                      |   |                                   |                         |                            |  |  |                                 |  |                                     |   |   |  |                               |                            |  |                           |                                   |  |  |   |                          |                                   |     |                               |     |                                  |                                     |   |                                  |                                   |               |                    |                         |     |                                  |                              |     |                                  |                                    |  |                                  |                                   |               |                    |                         |     |                                  |                              |   |                                     |  |                          |                           |                                 |                                 |                            |                          |     |     |                          |  |                                |                                  |                     |   |                              |                               |                                      |                                    |                    |   |
| Place of Clearing<br>---   | Transaction Activity Code<br>SETT                      | ---   |             |            |  |                                      |                                      |   |                                   |                         |                            |  |  |                                 |  |                                     |   |   |  |                               |                            |  |                           |                                   |  |  |   |                          |                                   |     |                               |     |                                  |                                     |   |                                  |                                   |               |                    |                         |     |                                  |                              |     |                                  |                                    |  |                                  |                                   |               |                    |                         |     |                                  |                              |   |                                     |  |                          |                           |                                 |                                 |                            |                          |     |     |                          |  |                                |                                  |                     |   |                              |                               |                                      |                                    |                    |   |
| Delivering CSD<br>CSDGNLA0XXX  | ---  | Processing Identification<br>---                                  |             |            |  |                                      |                                      |   |                                   |                         |                            |  |  |                                 |  |                                     |   |   |  |                               |                            |  |                           |                                   |  |  |   |                          |                                   |     |                               |     |                                  |                                     |   |                                  |                                   |               |                    |                         |     |                                  |                              |     |                                  |                                    |  |                                  |                                   |               |                    |                         |     |                                  |                              |   |                                     |  |                          |                           |                                 |                                 |                            |                          |     |     |                          |  |                                |                                  |                     |   |                              |                               |                                      |                                    |                    |   |
| Delivering T2S Party<br>CSDGNLA0XXX  | Delivering Party - Securities Account<br>ISSACGNL0001  | Processing Identification<br>---                                  |             |            |  |                                      |                                      |   |                                   |                         |                            |  |  |                                 |  |                                     |   |   |  |                               |                            |  |                           |                                   |  |  |   |                          |                                   |     |                               |     |                                  |                                     |   |                                  |                                   |               |                    |                         |     |                                  |                              |     |                                  |                                    |  |                                  |                                   |               |                    |                         |     |                                  |                              |   |                                     |  |                          |                           |                                 |                                 |                            |                          |     |     |                          |  |                                |                                  |                     |   |                              |                               |                                      |                                    |                    |   |
| Proprietary Identification<br>---  | Issuer<br>---  | Schema Name<br>---  |             |            |  |                                      |                                      |   |                                   |                         |                            |  |  |                                 |  |                                     |   |   |  |                               |                            |  |                           |                                   |  |  |   |                          |                                   |     |                               |     |                                  |                                     |   |                                  |                                   |               |                    |                         |     |                                  |                              |     |                                  |                                    |  |                                  |                                   |               |                    |                         |     |                                  |                              |   |                                     |  |                          |                           |                                 |                                 |                            |                          |     |     |                          |  |                                |                                  |                     |   |                              |                               |                                      |                                    |                    |   |
| Name and Address<br>---  | ---  | Processing Identification<br>---                                  |             |            |  |                                      |                                      |   |                                   |                         |                            |  |  |                                 |  |                                     |   |   |  |                               |                            |  |                           |                                   |  |  |   |                          |                                   |     |                               |     |                                  |                                     |   |                                  |                                   |               |                    |                         |     |                                  |                              |     |                                  |                                    |  |                                  |                                   |               |                    |                         |     |                                  |                              |   |                                     |  |                          |                           |                                 |                                 |                            |                          |     |     |                          |  |                                |                                  |                     |   |                              |                               |                                      |                                    |                    |   |
| Receiving CSD<br>CSDGNLA0XXX   | ---  | Processing Identification<br>---                                  |             |            |  |                                      |                                      |   |                                   |                         |                            |  |  |                                 |  |                                     |   |   |  |                               |                            |  |                           |                                   |  |  |   |                          |                                   |     |                               |     |                                  |                                     |   |                                  |                                   |               |                    |                         |     |                                  |                              |     |                                  |                                    |  |                                  |                                   |               |                    |                         |     |                                  |                              |   |                                     |  |                          |                           |                                 |                                 |                            |                          |     |     |                          |  |                                |                                  |                     |   |                              |                               |                                      |                                    |                    |   |
| Receiving T2S Party<br>PMBGNLA0XXX   | Receiving Party - Securities Account<br>CSDPCGNL0002   | Processing Identification<br>---                                  |             |            |  |                                      |                                      |   |                                   |                         |                            |  |  |                                 |  |                                     |   |   |  |                               |                            |  |                           |                                   |  |  |   |                          |                                   |     |                               |     |                                  |                                     |   |                                  |                                   |               |                    |                         |     |                                  |                              |     |                                  |                                    |  |                                  |                                   |               |                    |                         |     |                                  |                              |   |                                     |  |                          |                           |                                 |                                 |                            |                          |     |     |                          |  |                                |                                  |                     |   |                              |                               |                                      |                                    |                    |   |
| Proprietary Identification<br>---  | Issuer<br>---  | Schema Name<br>---  |             |            |  |                                      |                                      |   |                                   |                         |                            |  |  |                                 |  |                                     |   |   |  |                               |                            |  |                           |                                   |  |  |   |                          |                                   |     |                               |     |                                  |                                     |   |                                  |                                   |               |                    |                         |     |                                  |                              |     |                                  |                                    |  |                                  |                                   |               |                    |                         |     |                                  |                              |   |                                     |  |                          |                           |                                 |                                 |                            |                          |     |     |                          |  |                                |                                  |                     |   |                              |                               |                                      |                                    |                    |   |
| Name and Address<br>---  | ---  | Processing Identification<br>---                                  |             |            |  |                                      |                                      |   |                                   |                         |                            |  |  |                                 |  |                                     |   |   |  |                               |                            |  |                           |                                   |  |  |   |                          |                                   |     |                               |     |                                  |                                     |   |                                  |                                   |               |                    |                         |     |                                  |                              |     |                                  |                                    |  |                                  |                                   |               |                    |                         |     |                                  |                              |   |                                     |  |                          |                           |                                 |                                 |                            |                          |     |     |                          |  |                                |                                  |                     |   |                              |                               |                                      |                                    |                    |   |
| ISO Transaction Code<br>TRAD   | Settlement Transaction Condition Indicator<br>---      | Partial Settlement Indicator<br>---                               |             |            |  |                                      |                                      |   |                                   |                         |                            |  |  |                                 |  |                                     |   |   |  |                               |                            |  |                           |                                   |  |  |   |                          |                                   |     |                               |     |                                  |                                     |   |                                  |                                   |               |                    |                         |     |                                  |                              |     |                                  |                                    |  |                                  |                                   |               |                    |                         |     |                                  |                              |   |                                     |  |                          |                           |                                 |                                 |                            |                          |     |     |                          |  |                                |                                  |                     |   |                              |                               |                                      |                                    |                    |   |
| Corporate Action Event Identification<br>---   | CSD Hold Status<br>false                               | CoSD Hold Status<br>false   |             |            |  |                                      |                                      |   |                                   |                         |                            |  |  |                                 |  |                                     |   |   |  |                               |                            |  |                           |                                   |  |  |   |                          |                                   |     |                               |     |                                  |                                     |   |                                  |                                   |               |                    |                         |     |                                  |                              |     |                                  |                                    |  |                                  |                                   |               |                    |                         |     |                                  |                              |   |                                     |  |                          |                           |                                 |                                 |                            |                          |     |     |                          |  |                                |                                  |                     |   |                              |                               |                                      |                                    |                    |   |
| CoSD Rule Identification<br>---  | Validation Hold Status<br>false                        | Party Hold Status<br>false  |             |            |  |                                      |                                      |   |                                   |                         |                            |  |  |                                 |  |                                     |   |   |  |                               |                            |  |                           |                                   |  |  |   |                          |                                   |     |                               |     |                                  |                                     |   |                                  |                                   |               |                    |                         |     |                                  |                              |     |                                  |                                    |  |                                  |                                   |               |                    |                         |     |                                  |                              |   |                                     |  |                          |                           |                                 |                                 |                            |                          |     |     |                          |  |                                |                                  |                     |   |                              |                               |                                      |                                    |                    |   |
| Matching Status<br>false   | ---  | ---   |             |            |  |                                      |                                      |   |                                   |                         |                            |  |  |                                 |  |                                     |   |   |  |                               |                            |  |                           |                                   |  |  |   |                          |                                   |     |                               |     |                                  |                                     |   |                                  |                                   |               |                    |                         |     |                                  |                              |     |                                  |                                    |  |                                  |                                   |               |                    |                         |     |                                  |                              |   |                                     |  |                          |                           |                                 |                                 |                            |                          |     |     |                          |  |                                |                                  |                     |   |                              |                               |                                      |                                    |                    |   |
| Settlement Status<br>---   | Accepted Timestamp (SF1)<br>2021-04-07T10:28:16.74410Z | Matched Timestamp (SF2)<br>---                                    |             |            |  |                                      |                                      |   |                                   |                         |                            |  |  |                                 |  |                                     |   |   |  |                               |                            |  |                           |                                   |  |  |   |                          |                                   |     |                               |     |                                  |                                     |   |                                  |                                   |               |                    |                         |     |                                  |                              |     |                                  |                                    |  |                                  |                                   |               |                    |                         |     |                                  |                              |   |                                     |  |                          |                           |                                 |                                 |                            |                          |     |     |                          |  |                                |                                  |                     |   |                              |                               |                                      |                                    |                    |   |
| ISO Settlement-Status<br>Failing   | Reason Code<br>CYCL                                    | Reason Code Additional Information<br>AwaitingNextSettlementCycle |             |            |  |                                      |                                      |   |                                   |                         |                            |  |  |                                 |  |                                     |   |   |  |                               |                            |  |                           |                                   |  |  |   |                          |                                   |     |                               |     |                                  |                                     |   |                                  |                                   |               |                    |                         |     |                                  |                              |     |                                  |                                    |  |                                  |                                   |               |                    |                         |     |                                  |                              |   |                                     |  |                          |                           |                                 |                                 |                            |                          |     |     |                          |  |                                |                                  |                     |   |                              |                               |                                      |                                    |                    |   |
| Cancellation Requested<br>No   | Acknowledgement Status<br>---                          | Cancellation Status<br>Not Cancelled                              |             |            |  |                                      |                                      |   |                                   |                         |                            |  |  |                                 |  |                                     |   |   |  |                               |                            |  |                           |                                   |  |  |   |                          |                                   |     |                               |     |                                  |                                     |   |                                  |                                   |               |                    |                         |     |                                  |                              |     |                                  |                                    |  |                                  |                                   |               |                    |                         |     |                                  |                              |   |                                     |  |                          |                           |                                 |                                 |                            |                          |     |     |                          |  |                                |                                  |                     |   |                              |                               |                                      |                                    |                    |   |
| Pending Cancellation Status<br>---   | Reason Code<br>---                                     | Reason Code Additional Information<br>---                         |             |            |  |                                      |                                      |   |                                   |                         |                            |  |  |                                 |  |                                     |   |   |  |                               |                            |  |                           |                                   |  |  |   |                          |                                   |     |                               |     |                                  |                                     |   |                                  |                                   |               |                    |                         |     |                                  |                              |     |                                  |                                    |  |                                  |                                   |               |                    |                         |     |                                  |                              |   |                                     |  |                          |                           |                                 |                                 |                            |                          |     |     |                          |  |                                |                                  |                     |   |                              |                               |                                      |                                    |                    |   |

Illustration 106: Available report - statement of pending instructions - details screen

Field Description

| General Statement Information |  |
|-------------------------------|--|
| Report Name                   | Shows the name of the report.  |
| Delta Mode                    | Shows if the report is a delta report or not. Possible values are:<br><input type="checkbox"/> Yes |

| General Statement Information  |   |
|--------------------------------|---|
|                                | <input type="checkbox"/> No   |
| Statement Number               | Shows the statement number of the report composed of the business date and report type (2-letter abbreviation depending on report type and delta/full-flag) and the sequential number, which is unique in T2S.<br><br>The number increases for each report.             |
| Report Number                  | Shows the sequential number of the report which is specific for a report receiving party. This number will only be displayed if the sending user belongs to a report receiving party.   |
| Frequency                      | Shows the frequency of the report from the possible value:<br><input type="checkbox"/> DAILY (for reports created on a daily basis)   |
| Scheduled                      | Shows the name of the business event or time triggering the report creation.  |
| Activity Indicator             | Shows whether the report displays activities or only lists information from the possible values:<br><input type="checkbox"/> True<br><input type="checkbox"/> False   |
| Covered Period from            | Shows the date and time from which the data are covered in the report.<br><br>Displayed format is: YYYY-MM-DD hh:mm:ss  |
| Covered Period to              | Shows the date and time until which the data are covered in the report.<br><br>Displayed format is: YYYY-MM-DD hh:mm:ss   |
| Report Owner BIC               | Shows the BIC of the party whose data are reported.   |
| Report Owner Parent BIC        | Shows the parent BIC of the party whose data are reported.  |
| System Entity Wide Report      | Shows whether the report is a community report (covering all information referring to a system entity) or a party based report (covering all information referring to a party) from the possible values:<br><input type="checkbox"/> Yes<br><input type="checkbox"/> No |
| Securities Account Information |   |

| <b>General Statement Information</b>                            |   |
|---|---|
| Securities Account Number                                       | Shows the number of the securities account on which the report is based.  |
| Securities Account Owner BIC                                    | Shows the BIC of the party owning the securities account.   |
| Securities Account Servicer BIC                                 | Shows the BIC of the party operating the securities account.  |
| Transaction   |   |
| <b>Repetitive Block For Each Pending Settlement Instruction</b> |   |
| <b>Statement - Instruction References</b>                       |   |
| Account Owner Reference   | Shows the identification of the instruction assigned by the delivering/receiving party.   |
| Account Servicer Reference                                      | Shows the identification of an instruction as assigned by the CSD.  |
| Third Party Reference   | Shows the identification of the instruction assigned by a third party.  |
| Settlement Instruction Technical Identifier                     | Shows the identification of a settlement instruction as assigned by T2S.  |
| Pool Instruction Reference                                      | Shows the identification of a pool of settlement instructions or settlement restrictions.   |
| Common Reference  | Shows the identification the 2 trade counterparties agreed in order to identify the trade. This field is optional.                            |
| <b>Statement - Trade Timeline</b>                               |   |
| Trade Date  | Shows the date when the contract was made.<br>Displayed format is: YYYY-MM-DD   |
| Intended Settlement Date  | Shows the date when the instruction is forwarded to settlement for the first time.<br>Displayed format is: YYYY-MM-DD                         |
| <b>Statement - Trade Information</b>                            |   |
| Movement Type Code  | Shows the movement on a securities account from the possible values:<br><input type="checkbox"/> Delivery<br><input type="checkbox"/> Receive |
| Payment Type  | Shows the type of the payment from the possible values:<br><input type="checkbox"/> APMT (for against payment settlement)                     |

| General Statement Information                         |   |
|---|---|
|   | <input type="checkbox"/> FREE (for separate settlement)   |
| ISIN  | Shows the ISIN of the security.   |
| Name  | Shows the name of the party whose data are reported.  |
| Remaining Quantity                                    | Shows the quantity of securities to be settled.<br>It shows the result of original settlement quantity deducting the settled settlement quantity.                 |
| Settlement Type                                       | Shows the type of settlement from the possible values:<br><input type="checkbox"/> UNIT (Units)<br><input type="checkbox"/> FAMT (Face Amount)                    |
| Remaining Amount                                      | Shows the amount to be settled.<br>It shows the result of original/matched settlement amount deducting the settled settlement amount.                             |
| Debit Credit Indicator                                | Shows if an operation is a credit or a debit from the possible values:<br><input type="checkbox"/> CRDT (for credit)<br><input type="checkbox"/> DBIT (for debit) |
| Settlement Currency                                   | Shows the currency of the settlement.   |
| Place of Trade Market Identifier Code                 | Shows the identification of a financial market, as stipulated in the norm ISO 10383:2012 "Codes for exchanges and market identifications".                        |
| Place of Trade Description                            | Shows the description of the market when no Market Identifier Code is available.  |
| Place of Trade Market Type Code                       | Shows the market type expressed as an ISO 20022 code.   |
| Place of Trade Market Type Proprietary Identification | Shows the proprietary information, often a code, issued by the data source scheme issuer.   |
| Place of Trade Market Type Proprietary Issuer         | Shows the entity that assigns the identification.   |
| Place of Trade Market Type Proprietary Scheme Name    | Shows a short textual description of the scheme.  |
| Place of Clearing                                     | Shows the BIC code of the Clearing House involved in the settlement (if any).   |

| General Statement Information   |   |
|---|---|
| Transaction Activity Code   | Specifies the type of activity to which this instruction relates: <ul style="list-style-type: none"> <li><input type="checkbox"/> BOLE: Borrowing and Lending Activity;</li> <li><input type="checkbox"/> CLAI: Market Claim;</li> <li><input type="checkbox"/> COLL: Collateral Activity;</li> <li><input type="checkbox"/> CORP: Corporate Action Activity;</li> <li><input type="checkbox"/> SETT: Settlement and Clearing Activity</li> </ul> |
| <b>Settlement Parties</b>   |   |
| <b>Delivering Settlement Parties</b>  |   |
| This subframe is optional and only available for settlement instruction information   |   |
| <b>Delivering Depository</b>  |   |
| Party BIC   | Shows the BIC of the delivering depository.   |
| Processing Identification   | Shows the unambiguous identification of the transaction as assigned by the delivering depository.   |
| <b>Settlement Instruction Information – Settlement Parties – Delivering Settlement Parties – Delivering CSD Participant</b> |   |
| Party BIC   | Shows the BIC of the CSD participant delivering the securities.   |
| Securities Account Number   | Shows the securities account number of the delivering CSD participant.  |
| Processing Identification   | Shows the unambiguous identification of the transaction as assigned by the delivering CSD participant.  |
| <b>Client of the Delivering CSD Participant</b>   |   |
| <b>Specifying the party only via party BIC or its name or the triplet of identification, issuer and scheme name.</b>        |   |
| Party BIC   | Shows the BIC of the client of delivering CSD participant.  |
| Identification  | Shows the proprietary identification of the pre-mentioned party BIC.  |
| Issuer  | Shows the entity assigning the identification.  |
| Scheme Name   | Shows the name of the scheme.   |
| Name  | Shows the name of the client of delivering CSD participant.   |
| Processing Identification   | Shows the unambiguous identification of the transaction as assigned by the client of delivering CSD participant.  |



| <b>General Statement Information</b>   |   |
|--|---|
| <b>Receiving Settlement Parties</b>  |   |
| This subframe is optional and only available for settlement instruction information                                  |   |
| <b>Receiving Depository</b>  |   |
| Party BIC  | Shows the BIC of the receiving depository.  |
| Processing Identification  | Shows the unambiguous identification of the transaction as assigned by the receiving depository.  |
| <b>Receiving CSD Participant</b>   |   |
| Party BIC  | Shows the BIC of the CSD receiving the securities.  |
| Securities Account Number  | Shows the securities account number of the receiving CSD participant.   |
| Processing Identification  | Shows the unambiguous identification of the transaction as assigned by the receiving CSD participant.   |
| <b>Client of the Receiving CSD Participant</b>   |   |
| <b>Specifying the party only via party BIC or its name or the triplet of identification, issuer and scheme name.</b> |   |
| Party BIC  | Shows the BIC of the client of receiving CSD participant.   |
| Identification   | Shows the proprietary identification of the pre-mentioned party BIC.  |
| Issuer   | Shows the entity assigning the identification.  |
| Scheme Name  | Shows the name of the scheme.   |
| Name   | Shows the name of the client of receiving CSD participant.  |
| Process Identification   | Shows the unambiguous identification of the transaction as assigned by the client of receiving CSD participant.   |
| <b>Statement - Further Information</b>   |   |
| ISO Transaction Code   | Shows the transaction code as defined in ISO20022   |
| Settlement Transaction Condition Indicator   | Shows the Settlement Transaction Condition Indicator.<br>This field can show multiple Settlement Transaction Condition Indicators.  |
| Partial Settlement Indicator   | Shows if the settlement instruction is allowed to be subject to partial settlement from the possible values: <ul style="list-style-type: none"> <li><input type="checkbox"/> NPAR (for no partial settlement allowed)</li> <li><input type="checkbox"/> PART (for partial settlement allowed without restrictions)</li> </ul> |

| General Statement Information         |   |
|---------------------------------------|---|
|                                       | <input type="checkbox"/> PARC (for partial settlement allowed but the settlement amount must not be below the threshold)<br><input type="checkbox"/> PARQ (for partial settlement allowed but the quantity must not be below the threshold) |
| Corporate Action Event Identification | Shows the identification of the instruction assigned by the account servicer to identify a corporate action event.  |
| CSD Hold Status                       | Shows the hold status as set by the CSD from the possible values:<br><input type="checkbox"/> Yes<br><input type="checkbox"/> No (default value)  |
| CoSD Hold Status                      | Shows whether the settlement instruction fulfills 1 CoSD rule configured in reference data from the possible values:<br><input type="checkbox"/> Yes<br><input type="checkbox"/> No (default value)   |
| CoSD Rule Identification              | Shows the identification of the respective CoSD rule.   |
| CSD Validation Hold Status            | Shows whether the settlement instruction fulfills 1 market-specific restriction configured in reference data from the possible values:<br><input type="checkbox"/> Yes<br><input type="checkbox"/> No                                       |
| Party Hold Status                     | Shows the hold status as set by the T2S party from the possible values:<br><input type="checkbox"/> Yes<br><input type="checkbox"/> No  |
| Status Information                    |   |
| Matching status                       | Shows the matching status of the (cancellation) instruction from the possible values:<br><input type="checkbox"/> MACH (matched)<br><input type="checkbox"/> NMAT (unmatched)   |
| Accepted Timestamp (SF1)              | Shows the accepted timestamp of the settlement instruction.<br>Displayed format is: YYYY-MM-DD hh:mm:ss:µsµsµsµsµs  |
| Matched Timestamp (SF2)               | Shows the matched timestamp of the settlement instruction.  |

| General Statement Information                        |  |
|--|--|
|  | <p>In case the settlement instruction is unmatched no timestamp will be shown.</p> <p>Displayed format is: YYYY-MM-DD hh:mm:ss:μsμsμsμsμs</p>  |
| Settlement Status                                    | <p>Shows the status of the settlement instruction from the possible values:</p> <ul style="list-style-type: none"> <li><input type="checkbox"/> USET (for unsettled)</li> <li><input type="checkbox"/> PSET (for partially settled)</li> </ul> |
| ISO Settlement Status                                | <p>Shows the ISO settlement status of the settlement instruction from the possible values:</p> <ul style="list-style-type: none"> <li><input type="checkbox"/> Pending</li> <li><input type="checkbox"/> Failing</li> </ul>                    |
| Settlement Status Reason Code                        | Shows the reason code why an instruction has a certain settlement status.  |
| Settlement Status Reason Code Additional Information | Shows additional information on the reason code.   |
| Cancellation Requested                               | <p>Shows whether a cancellation was requested from the counterparty for this transaction from the possible values:</p> <ul style="list-style-type: none"> <li><input type="checkbox"/> Yes</li> <li><input type="checkbox"/> No</li> </ul>     |
| Acknowledged Accepted                                | <p>Shows whether the account servicer acknowledged the instruction from the possible values:</p> <ul style="list-style-type: none"> <li><input type="checkbox"/> Yes</li> <li><input type="checkbox"/> No</li> </ul>                           |
| Cancellation Status                                  | <p>Shows the current cancellation status of the instruction from the possible values:</p> <ul style="list-style-type: none"> <li><input type="checkbox"/> Cancelled</li> <li><input type="checkbox"/> Not cancelled</li> </ul>                 |
| Pending Cancellation Status                          | <p>Shows the status of the instruction from the possible values:</p> <ul style="list-style-type: none"> <li><input type="checkbox"/> CANC (for cancelled)</li> <li><input type="checkbox"/> NCAN (for not cancelled)</li> </ul>                |
| Pending Cancellation Status Reason Code              | Shows the reason for the pending status.   |

| General Statement Information                                    |  |
|--|--|
| Pending Cancellation Status – Reason Code Additional Information | Shows additional information on the reason code. |

## 2.4.1.15 Available Report - Statement of Pending Intra-Balance Movements - Details Screen

### Context of Usage

This screen displays detailed information on pending intra-balance movements.

The report displayed in this screen has to be already created in accordance with its report configuration.

This screen is not relevant for CSD, external CSD and CSD participant users.

### Screen Access

Services >> Additional Services >> Reports >> *Available reports – search/list* screen >> Click on the *details* button

Services >> Additional Services >> Reports >> *Available reports – search/list* screen >> Click on the *search* and/or *details* button >> *Available report – details* screen >> Click on the *details* button

### Privileges

To use this screen, you need the following privilege [[▶ 872](#)]:

Report details query

### References

#### User Instructions Part

This screen is part of the following business scenario:

View available reports

#### Business Functionality Document

This screen corresponds to the following business function:

Display generated report details (T2S.GUI.INSE.RPT.0090)

Screenshot

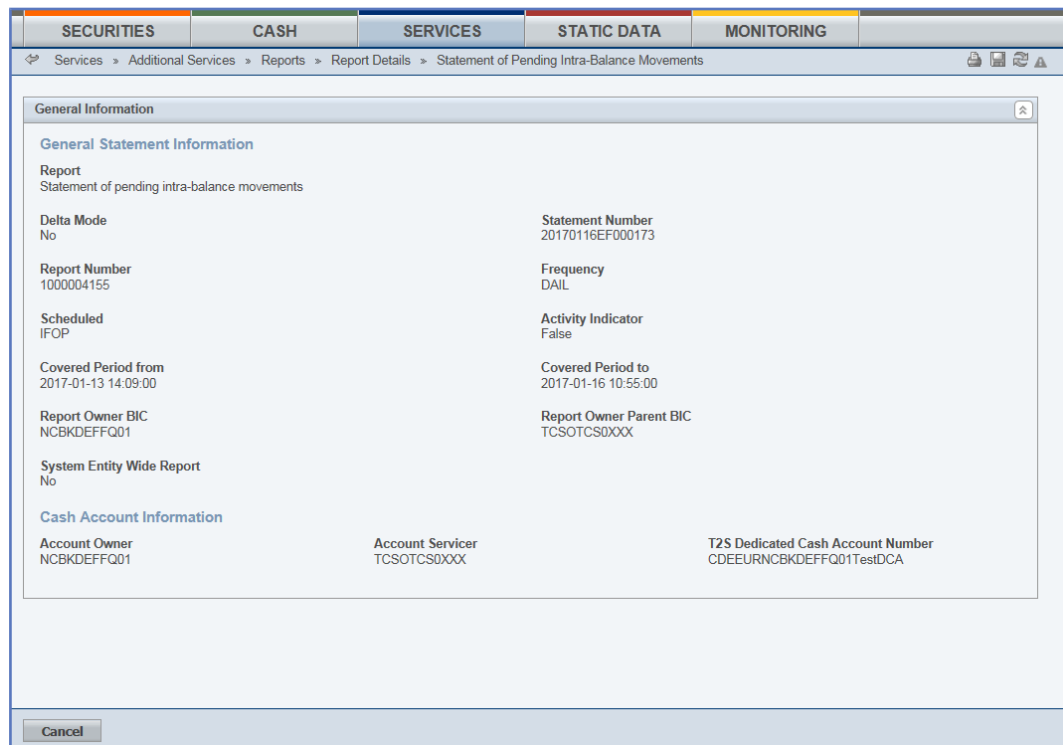

Illustration 107: Available report – statement of pending intra-balance movements – details screen

Field

Description

| General Statement Information |   |
|-------------------------------|---|
| Report Name                   | Shows the name of the report.   |
| Delta Mode                    | Shows if the report is a delta report or not. Possible values are:<br><input type="checkbox"/> Yes<br><input type="checkbox"/> No   |
| Statement Number              | Shows the statement number of the report composed of the business date and report type (2-letter abbreviation depending on report type and Delta/Full-Flag) and the sequential number, which is unique in T2S.<br>The number increases for each report. |
| Report Number                 | Shows the sequential number of the report which is specific for a report receiving party.<br>This number will only be displayed if the sending user belongs to a report receiving party.  |
| Frequency                     | Shows the frequency of the report, which is always 'DAILY'.   |
| Scheduled                     | Shows the name of the business event or time triggering the report creation.  |

| General Statement Information                    |   |
|--|---|
| Activity Indicator                               | Shows whether the report displays activities or only lists information from the possible values:<br><br><input type="checkbox"/> True<br><input type="checkbox"/> False   |
| Covered Period From                              | Shows the date and time from which the data are covered in the report.<br><br>Displayed format is: YYYY-MM-DD hh:mm:ss  |
| Covered Period To                                | Shows the date and time until which the data are covered in the report.<br><br>Displayed format is: YYYY-MM-DD hh:mm:ss   |
| Report Owner BIC                                 | Shows the BIC of the party whose data are reported.   |
| Report Owner Parent BIC                          | Shows the parent BIC of the party whose data are reported.  |
| System Entity Wide Report                        | Shows whether the report is a community report (covering all information referring to a system entity) or a party based report (covering all information referring to a party).<br>from the possible values:<br><br><input type="checkbox"/> Yes<br><input type="checkbox"/> No |
| Cash Account Information                         |   |
| T2S Dedicated Cash Account Owner BIC             | Shows the BIC of the party owning the T2S dedicated cash account.   |
| T2S Dedicated Cash Account Owner Parent BIC      | Shows the parent BIC of the party owning the dedicated cash account.  |
| T2S Dedicated Cash Account Number                | Shows the T2S dedicated cash account for which the report is created.   |
| Intra-Balance Movement Information               |   |
| Repetitive Block For Each Intra-Balance Movement |   |
| Intra-Balance Movement Information               |   |
| Settlement Status                                | Shows the settlement status of the instruction from the possible values:<br><br><input type="checkbox"/> USET (for unsettled) (default value)<br><input type="checkbox"/> SETT (for settled)<br><input type="checkbox"/> PSET (for partially settled)                           |

| General Statement Information               |   |
|---|---|
| ISO Settlement Status                       | Shows the ISO settlement status of the settlement restriction from the possible values:<br><br><input type="checkbox"/> Pending<br><input type="checkbox"/> Failing |
| Settlement Status Reason Code               | Shows the reason code why an instruction has a certain settlement status.   |
| Settlement Status Reason Information        | Shows additional settlement status information.   |
| Cancellation Status                         | Shows the status of the instruction from the possible values:<br><br><input type="checkbox"/> DEND (for denied)<br><input type="checkbox"/> NDEN (for not denied)   |
| Cancellation Status Reason Code             | Shows the reason code for the cancellation.   |
| Cancellation Status Additional Information  | Shows additional information on the cancellation status.  |
| Last Update of Status                       | Shows the date and time of the last status update.<br><br>Displayed format is: YYYY-MM-DD hh:mm:ss:µsµsµsµsµs   |
| References                                  |   |
| Intra-Balance Movement Technical Identifier | Shows the unique technical identification of the intra-balance movement assigned by T2S.  |
| Account Owner Reference                     | Shows the reference of the instruction which is assigned by the T2S delivering/receiving party.   |
| Account Servicer Reference                  | Shows the reference of the instruction assigned by the account referencer.  |
| Third Party Reference                       | Shows the identification of the instruction assigned by a third party.  |
| Pool Instruction Reference                  | Shows the identification of a pool of settlement instructions or settlement restrictions.   |
| Restriction Reference                       | Shows the identification of the restriction assigned by T2S.  |
| Settlement Information                      |   |

| General Statement Information           |  |
|---|--|
| Restriction Type Balance from           | Shows the restriction type code of a balance of a T2S dedicated cash account which is debited.   |
| Restriction Type Balance to             | Shows the restriction type code of a balance of a T2S dedicated cash account which is credited.  |
| Currency                                | Shows the currency code.   |
| Original Settlement Amount              | Shows the amount as stated in the settlement instruction.  |
| Intended Settlement Date                | Shows the date when the instruction is forwarded to settlement for the first time.<br><br>Displayed format is: YYYY-MM-DD  |
| Priority                                | Shows the priority of the payment instruction assigned by the originator of the instruction from the possible values: <ul style="list-style-type: none"> <li><input type="checkbox"/> High</li> <li><input type="checkbox"/> Normal</li> <li><input type="checkbox"/> Reserved</li> <li><input type="checkbox"/> Top</li> </ul>  |
| Instruction Link Information            |  |
| Link Type                               | Shows the link type of the instruction from the possible values: <ul style="list-style-type: none"> <li><input type="checkbox"/> Afte (Instruction has to be settled after or at the same time as the linked instruction)</li> <li><input type="checkbox"/> Befo (Instruction has to be settled before or at the same time as the linked instruction)</li> <li><input type="checkbox"/> With (Instruction has to be settled at the same time as the linked instruction)</li> <li><input type="checkbox"/> Info (Specifies that the instructions are linked for information purposes only)</li> </ul> |
| Message Number                          | Shows the identification of the message referenced in the linked sequence.   |
| Linked Instruction Reference of a Party | Shows the T2S actor reference of the LCMM instruction linked to the relevant LCMM instruction.<br><br>In case a link between 2 or more LCMM instructions exists, the ISO settlement link indicators <ul style="list-style-type: none"> <li><input type="checkbox"/> After</li> <li><input type="checkbox"/> Before</li> </ul>  |



| General Statement Information                  |  |
|--|--|
|  | <input type="checkbox"/> All-or-none<br><input type="checkbox"/> are used.                               |
| Linked Instruction<br>T2S Technical Identifier | Shows the technical identification of the linked instruction.  |
| Received Account<br>Owner BIC                  | BIC of the T2S party owner of the reference of the instruction/pool which this instruction is linked to. |
| Pool Instruction Reference                     | Shows the identification of a pool of settlement instructions or settlement restrictions.                |
| Instructing Party                              |  |
| Instructing Party BIC                          | Shows the BIC of the instructing party.  |
| Instructing Party<br>Parent BIC                | Shows the parent BIC of the instructing party.   |
| Entry Date and Time                            | Shows the entry date and time of an instruction.<br>Displayed format: YYYY-MM-DD hh:mm:ss                |

## 2.4.1.16 Available Report - Statement of Pending Intra-Position Movements - Details Screen

### Context of Usage

This screen displays detailed information on the selected statement of pending intra-position movements. The displayed report in this screen has to be already created in accordance with its report configuration.

This screen is not relevant for CB and payment bank/settlement bank users.

### Screen Access

Services >> Additional Services >> Reports >> *Available reports – search/list* screen >> Click on the *details* button

Services >> Additional Services >> Reports >> *Available reports – search/list* screen >> Click on the *search* and/or *details* button >> *Available report – details* screen >> Click on the *details* button

### Privileges

To use this screen, you need the following privilege [**▶ 873**]:

Report details query

### References

#### User Instructions Part

This screen is part of the following business scenario:

View available reports

#### Business Functionality Document

This screen corresponds to the following business function:

Display generated report details (T2S.GUI.INSE.RPT.0090)

Screenshot

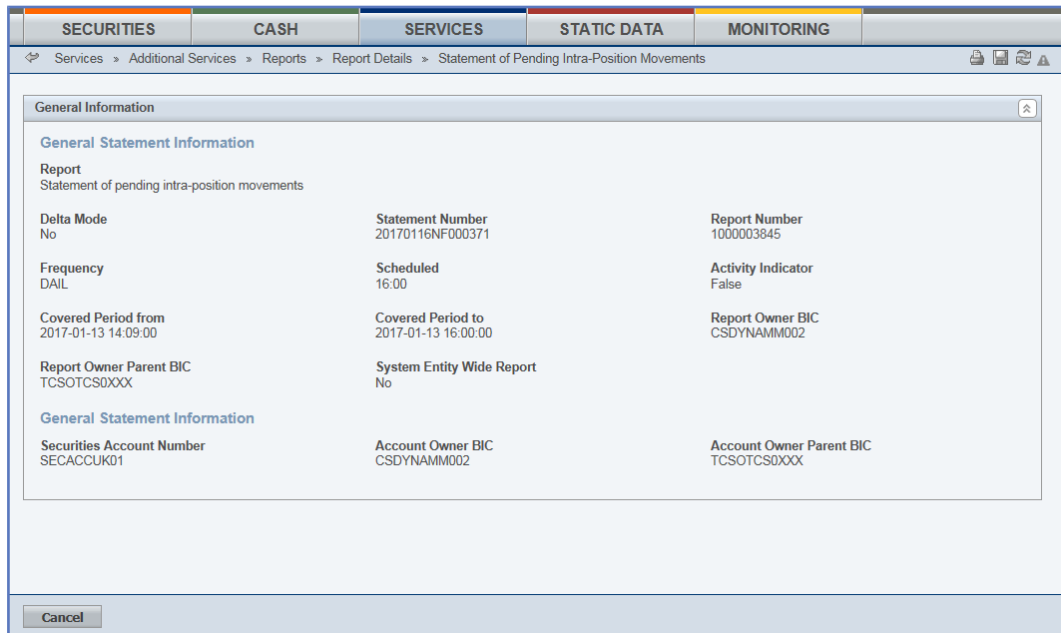

Illustration 108: Available report - statement of pending intra-position movements - details screen

Field

Description

| General Statement Information |   |
|-------------------------------|---|
| Report Name                   | Shows the name of the report.   |
| Delta Mode                    | Shows if the report is a delta report or not. Possible values are:<br><input type="checkbox"/> Yes<br><input type="checkbox"/> No   |
| Statement Number              | Shows the statement number of the report composed of the business date and report type (2-letter abbreviation depending on report type and delta/full-flag) and the sequential number, which is unique in T2S.<br><br>The number increases for each report. |
| Report Number                 | Shows the sequential number of the report which is specific for a report receiving party. This number will only be displayed if the sending user belongs to a report receiving party.   |
| Scheduled                     | Shows the name of the business event or time triggering the report creation.  |
| Frequency                     | Shows the frequency of the report from the possible value:<br><input type="checkbox"/> DAILY (for reports created on a daily basis)   |
| Activity Indicator            | Shows whether the report displays activities or only lists information from the possible values:<br><input type="checkbox"/> True   |

| General Statement Information                     |   |
|---|---|
|   | <input type="checkbox"/> False  |
| Covered Period from                               | Shows the date and time from which the data are covered in the report.<br>Displayed format is: YYYY-MM-DD hh:mm:ss  |
| Covered Period to                                 | Shows the date and time until which the data are covered in the report.<br>Displayed format is: YYYY-MM-DD hh:mm:ss   |
| Report Owner BIC                                  | Shows the BIC of the party whose data are reported.   |
| Report Owner Parent BIC                           | Shows the parent BIC of the party whose data are reported.  |
| System Entity Wide Report                         | Shows whether the report is a community report (covering all information referring to a system entity) or a party based report (covering all information referring to a party) from the possible values:<br><br><input type="checkbox"/> Yes<br><input type="checkbox"/> No |
| General Information                               |   |
| Securities Account Number                         | Shows the number of the securities account.   |
| Account Owner BIC                                 | Shows the BIC of the party which owns the securities account.   |
| Account Owner Parent BIC                          | Shows the parent BIC of the party.  |
| Intra-Position Movement Information               |   |
| Repetitive Block For Each Intra-Position Movement |   |
| Intra-Position Movement References                |   |
| Account Owner Reference                           | Shows the identification of the instruction assigned by the T2S delivering/receiving party.   |
| Account Servicer Reference                        | Shows the identification of the transaction assigned by the CSD.  |
| Third Party Reference                             | Shows the identification of the instruction assigned by a third party.  |
| Intra-Position Movement Reference                 | Shows the identification of the instruction assigned by the T2S system.   |
| Pool Identification                               | Shows the grouped LCMM instructions.  |

| General Statement Information   |   |
|---------------------------------|---|
| Intra-Position Movement Details |   |
| Instructing Party BIC           | Shows the BIC of the instructing party.   |
| Instructing Party Parent BIC    | Shows the parent BIC of the instructing party.  |
| Entry Date and Time             | Shows the date and time when the instruction entered T2S.<br>Displayed format is: YYYY-MM-DD hh:mm:ss   |
| Intended Settlement Date        | Shows the date when the instruction is forwarded to settlement for the first time.<br>Displayed format is: YYYY-MM-DD   |
| Priority                        | Shows the priority of the payment instruction assigned by the originator of the instruction from the possible values: <ul style="list-style-type: none"> <li><input type="checkbox"/> High</li> <li><input type="checkbox"/> Normal</li> <li><input type="checkbox"/> Reserved</li> <li><input type="checkbox"/> Top</li> </ul> |
| ISIN                            | Shows the ISIN of the security.   |
| Settlement Type                 | Shows the type of settlement from the possible values: <ul style="list-style-type: none"> <li><input type="checkbox"/> UNIT (Units)</li> <li><input type="checkbox"/> FAMT (Face Amount)</li> </ul>   |
| Original Settlement Quantity    | Shows the quantity of securities to be settled.   |
| Restriction Type Balance from   | Shows the restriction type code of a position of a debited securities account.  |
| Issuer                          | Shows the entity assigning the identification. The fixed value is 'T2S'.  |
| Scheme Name                     | Shows the name of the scheme.   |
| Restriction Type Balance to     | Shows the securities position to be credited.   |
| Issuer                          | Shows the entity assigning the identification. The fixed value is 'T2S'.  |
| Scheme Name                     | Shows the name of the scheme.   |

| General Statement Information |   |
|-------------------------------|---|
| Restriction Reference         | Shows the identification of the restriction assigned by T2S.  |
| Status Information            |   |
| Last Update of Status         | Shows the date and time of the last status update.<br>Displayed format is: YYYY-MM-DD hh:mm:ss  |
| Accepted Timestamp (SF1)      | Shows the accepted timestamp of the settlement restriction.<br>Displayed format is: YYYY-MM-DD hh:mm:ss:µsµsµsµsµs  |
| Settlement Status             | Shows the settlement status of the instruction from the possible values:<br><input type="checkbox"/> USET (for unsettled)<br><input type="checkbox"/> SETT (for settled)<br><input type="checkbox"/> PSET (for partially settled) |
| ISO Settlement Status         | Shows the ISO settlement status of the settlement restriction from the possible values:<br><input type="checkbox"/> Pending<br><input type="checkbox"/> Failing   |
| Reason Code                   | Shows the code of the reason why the instruction has a certain settlement status according to ISO20022.   |
| Reason Code Description       | Shows the detailed description of the reason code.  |
| Cancellation Status           | Shows the status of the instruction from the possible values:<br><input type="checkbox"/> Cancelled<br><input type="checkbox"/> Not Cancelled   |
| Reason Code                   | Shows the code of the reason why the related instruction has a certain settlement status according to ISO20022.   |
| Reason Code Description       | Shows the detailed description of the reason code.  |
| Link Information              |   |
| Link Type                     | Shows the link type of the instruction from the possible values:<br><input type="checkbox"/> Afte (instruction has to be settled after or at the same time as the linked instruction)   |

| General Statement Information   |  |
|---------------------------------|--|
|                                 | <input type="checkbox"/> Befo (instruction has to be settled before or at the same time as the linked instruction)<br><input type="checkbox"/> With (instruction has to be settled at the same time as the linked instruction)<br><input type="checkbox"/> Info (specifies that the instructions are linked for information purposes only) |
| Message Number                  | Shows the identification of the message referenced in the linked sequence.   |
| T2S Instruction Reference       | Shows the T2S technical identification of the linked instructions.   |
| T2S Actor Instruction Reference | Shows the identification of the instruction assigned by the T2S actor.   |
| Pool Identification             | Shows the grouped LCMM instructions.   |
| Received Account Owner BIC      | Shows the BIC of the T2S party owner of the referenced instruction/pool which the instruction is linked to.  |

### 2.4.1.17 Available Report - Statement of Settled Intra-Balance Movements - Details Screen

|                         |   |
|-------------------------|---|
| <b>Context of Usage</b> | <p>This screen displays detailed information on the selected statement of settled intra-balance movements. The report displayed in this screen has to be already created in accordance with its report configuration.</p> <p>This screen is not relevant for CSD, external CSD and CSD participant users.</p>   |
| <b>Screen Access</b>    | <ul style="list-style-type: none"> <li><input type="checkbox"/> Services &gt;&gt; Additional Services &gt;&gt; Reports &gt;&gt; <i>Available reports – search/list</i> screen &gt;&gt; Click on the <i>details</i> button</li> <li><input type="checkbox"/> Services &gt;&gt; Additional Services &gt;&gt; Reports &gt;&gt; <i>Available reports – search/list</i> screen &gt;&gt; Click on the <i>search</i> and/or <i>details</i> button &gt;&gt; <i>Available report – details</i> screen &gt;&gt; Click on the <i>details</i> button</li> </ul> |
| <b>Privileges</b>       | <p>To use this screen, you need the following privilege [▶ 873]:</p> <ul style="list-style-type: none"> <li><input type="checkbox"/> Report details query</li> </ul>  |
| <b>References</b>       | <p><b>User Instructions Part</b></p> <p>This screen is part of the following business scenario:</p> <ul style="list-style-type: none"> <li><input type="checkbox"/> View available reports</li> </ul> <p><b>Business Functionality Document</b></p> <p>This screen corresponds to the following business function:</p> <ul style="list-style-type: none"> <li><input type="checkbox"/> Display generated report details (T2S.GUI.INSE.RPT.0090)</li> </ul>  |

Screenshot

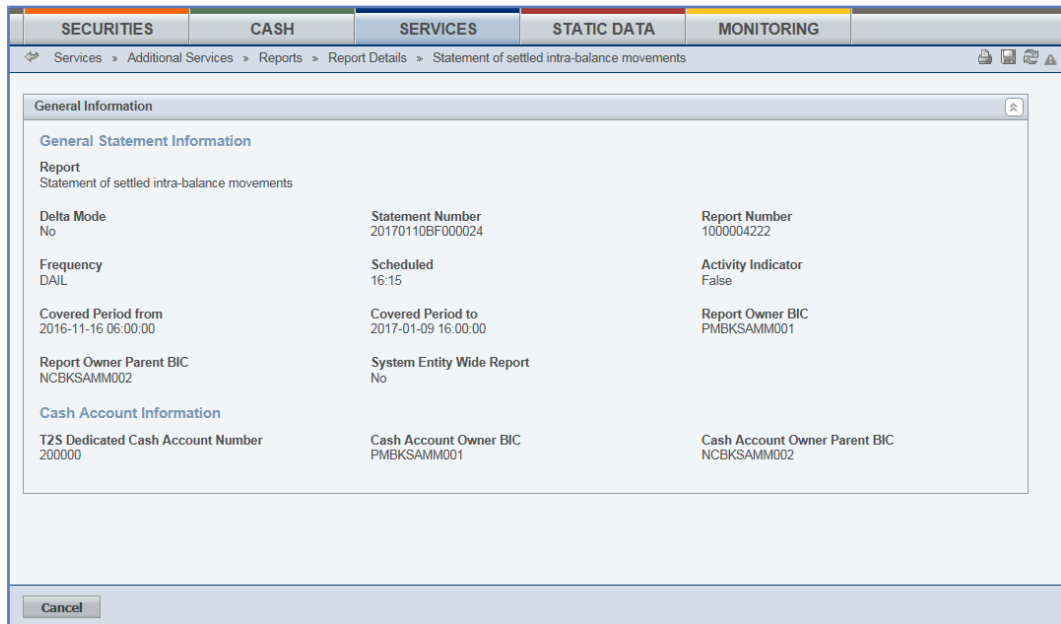

Illustration 109: Available report - statement of settled intra-balance movements - details screen

Field

Description

| General Statement Information |   |
|-------------------------------|---|
| Report Name                   | Shows the name of the report.   |
| Delta Mode                    | Shows if the report is a delta report or not. Possible values are:<br><input type="checkbox"/> Yes<br><input type="checkbox"/> No   |
| Statement Number              | Shows the statement number of the report composed of the business date and report type (2-letter abbreviation depending on report type and Delta/Full-Flag) and the sequential number, which is unique in T2S.<br>The number increases for each report. |
| Report Number                 | Shows the sequential number of the report which is specific for a report receiving party.<br>This number will only be displayed if the sending user belongs to a report receiving party.  |
| Scheduled                     | Shows the name of the business event or time triggering the report creation.  |
| Frequency                     | Shows the frequency of the report, which is always 'DAILY'.   |
| Activity Indicator            | Shows whether the report displays activities or only lists information from the possible values:<br><input type="checkbox"/> True   |

| General Statement Information  |   |
|--|---|
|  | <input type="checkbox"/> False  |
| Covered Period From  | Shows the date and time from which the data are covered in the report.<br>Displayed format is: YYYY-MM-DD hh:mm:ss  |
| Covered Period to  | Shows the date and time until which the data are covered in the report.<br>Displayed format is: YYYY-MM-DD hh:mm:ss   |
| Report Owner BIC   | Shows the BIC of the party whose data are reported.   |
| Report Owner Parent BIC  | Shows the parent BIC of the party whose data are reported.  |
| System Entity Wide Report  | Shows whether the report is a community report (covering all information referring to a system entity) or a party based report (covering all information referring to a party).<br>from the possible values:<br><input type="checkbox"/> Yes<br><input type="checkbox"/> No |
| Intra-Balance Movement Information<br>Repetitive Block for each Intra-Balance Movement |   |
| Cash Account Information   |   |
| T2S Dedicated Cash Account Number  | Shows the T2S dedicated cash account for which the report is created.   |
| T2S Dedicated Cash Account Owner BIC   | Shows the BIC of the party owning the T2S dedicated cash account.   |
| T2S Dedicated Cash Account Owner Parent BIC  | Shows the parent BIC of the party owning the dedicated cash account.  |
| Intra-Balance Movement - References  |   |
| Intra-Balance Movement Technical Identifier  | Shows the unique technical identification of the intra-balance movement assigned by T2S.  |
| Actor Reference  | Shows the identification of the instruction assigned by the T2S actor.  |



| General Statement Information                       |   |
|---|---|
| Account Owner Reference                             | Shows the identification of the instruction assigned by the T2S delivering/receiving party.   |
| Account Servicer Reference                          | Shows the identification of the instruction assigned by the account servicer.   |
| Third Party Reference                               | Shows the identification of the instruction assigned by a third party.  |
| Pool Instruction Reference                          | Shows the identification of a pool of settlement instructions or settlement restrictions.   |
| Restriction Reference                               | Shows the identification of the restriction assigned by T2S.  |
| Intra-Balance Movement – Settlement Information     |   |
| Currency  | Shows the currency code.  |
| Settled Settlement Amount in the last status update | Shows the amount which was settled in the last status update.   |
| Settled Settlement Amount                           | Shows the total settled amount.   |
| Remaining Settlement Amount                         | Shows the settlement amount remaining still to be settled.  |
| Actual Settlement Date                              | Shows the date of the settlement.<br>Displayed format is: YYYY-MM-DD  |
| Last Update of Status                               | Shows the date and time of the last status update.<br>Displayed format is: YYYY-MM-DD hh:mm:ss:µsµsµsµsµs   |
| Restriction Type Balance from                       | Shows the restriction type code of a balance of a T2S dedicated cash account which is debited.  |
| Restriction Type Balance to                         | Shows the restriction type code of a balance of a T2S dedicated cash account which is credited.   |
| Priority  | Shows the priority of the payment instruction assigned by the originator of the instruction from the possible values: <ul style="list-style-type: none"> <li><input type="checkbox"/> High</li> <li><input type="checkbox"/> Normal</li> <li><input type="checkbox"/> Reserved</li> <li><input type="checkbox"/> Top</li> </ul> |
| Intra-Balance Movement – Instructing Party          |   |

| General Statement Information  |   |
|--|---|
| Instructing Party BIC  | Shows the BIC of the instructing party.   |
| Instructing Party Parent BIC   | Shows the parent BIC of the instructing party.  |
| Entry Date and Time  | Shows the date and time when the instructions entered in T2S.<br>Displayed format is: YYYY-MM-DD hh:mm:ss   |
| Intra-Balance Movement - Status  |   |
| Settlement Status  | Shows the settlement status of the instruction from the possible values:<br><input type="checkbox"/> SETT (for settled)<br><input type="checkbox"/> PSET (for partially settled)  |
| Intra-Balance Movement – Instruction Link Information                  |   |
| Repetitive Block for each Intra-Balance Movement with Link Information |   |
| Link Type  | Shows the link type of the instruction from the possible values:<br><input type="checkbox"/> Afte (Instruction has to be settled after or at the same time as the linked instruction)<br><input type="checkbox"/> Befo (Instruction has to be settled before or at the same time as the linked instruction)<br><input type="checkbox"/> With (Instruction has to be settled at the same time as the linked instruction)<br><input type="checkbox"/> Info (Specifies that the instructions are linked for information purposes only) |
| Message Number   | Shows the identification of the message referenced in the linked sequence.  |
| Linked Instruction Reference of Party                                  | Shows the T2S actor reference of the LCMM instruction linked to the relevant LCMM instruction.<br>In case a link between 2 or more LCMM instructions exists, the ISO settlement link indicators are shown from the possible values:<br><input type="checkbox"/> After<br><input type="checkbox"/> Before<br><input type="checkbox"/> All-or-none  |

| General Statement Information               |  |
|---|--|
| Linked Instruction T2S Technical Identifier | Shows the technical identification of the linked instruction.  |
| Pool Instruction Reference                  | Shows the identification of a pool of settlement instructions or settlement restrictions.                          |
| Received Account Owner BIC                  | Shows the BIC of the T2S party owner of the reference of the instruction/pool which this instruction is linked to. |

## 2.4.1.18 Available Report - Statement of Settled Intra-Position Movements - Details Screen

**Context of Usage** This screen displays detailed information on the selected statement of settled intra-position movements. The report displayed in this screen has to be already created in accordance with its report configuration.

This screen is not relevant for CB and payment bank/settlement bank users.

**Screen Access**

- Services >> Additional Services >> Reports >> *Available reports – search/list* screen >> Click on the *search* and/or *details* button
- Services >> Additional Services >> Reports >> *Available reports – search/list* screen >> Click on the *search* and/or *details* button >> *Available report – details* screen >> Click on the *details* button

**Privileges** To use this screen, you need the following privilege [[▶ 873](#)]:

- Report details query

**References** **User Instructions Part**

This screen is part of the following business scenario:

- View available reports

**Business Functionality Document**

This screen corresponds to the following business function:

- Display generated reports list (T2S.GUI.INSE.RPT.0090)

Screenshot

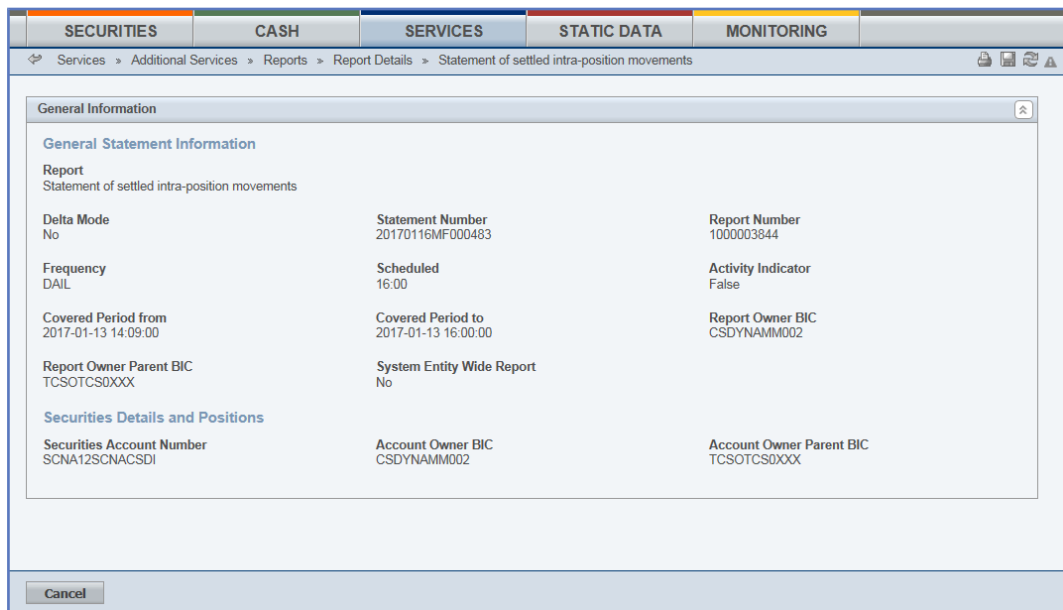

Illustration 110: Available report – statement of settled intra-position movements – details screen

Field

Description

| General Statement Information |   |
|-------------------------------|---|
| Report Name                   | Shows the name of the report.   |
| Delta Mode                    | Shows if the report is a delta report or not. Possible values are:<br><input type="checkbox"/> Yes<br><input type="checkbox"/> No   |
| Statement Number              | Shows the statement number of the report composed of the business date and report type (2-letter abbreviation depending on report type and delta/full-flag) and the sequential number, which is unique in T2S.<br><br>The number increases for each report. |
| Report Number                 | Shows the sequential number of the report which is specific for a report receiving party. This number will only be displayed if the pending user belongs to a report receiving party.   |
| Scheduled                     | Shows the name of the business event or time triggering the report creation.  |
| Frequency                     | Shows the frequency of the report from the possible value:<br><input type="checkbox"/> DAILY (for reports created on a daily basis)   |
| Activity Indicator            | Shows whether the report displays activities or only lists information from the possible values:<br><input type="checkbox"/> True<br><input type="checkbox"/> False   |

| General Statement Information                     |   |
|---|---|
| Covered Period from                               | Shows the date and time from which the data are covered in the report.<br>Displayed format is: YYYY-MM-DD hh:mm:ss  |
| Covered Period to                                 | Shows the date and time until which the data are covered in the report.<br>Displayed format is: YYYY-MM-DD hh:mm:ss   |
| Report Owner BIC                                  | Shows the BIC of the party whose data are reported.   |
| Report Owner Parent BIC                           | Shows the parent BIC of the party whose data are reported.  |
| System Entity Wide Report                         | Shows whether the report is a community report (covering all information referring to a system entity) or a party based report (covering all information referring to a party) from the possible values:<br><input type="checkbox"/> True<br><input type="checkbox"/> False |
| General Information                               |   |
| Securities Account Number                         | Shows the number of the securities account.   |
| Securities Account Owner BIC                      | Shows the BIC of the party which owns the securities account.   |
| Securities Account Owner Parent BIC               | Shows the parent BIC of the party.  |
| Intra-Position Movement Information               |   |
| Repetitive Block for each Intra-Position Movement |   |
| T2S Intra-Position Movement Reference             |   |
| Intra-Position Movement Reference                 | Shows the identification of the instruction assigned by T2S.  |
| Intra-Balance Movement Details                    |   |
| ISIN  | Shows the ISIN of the security.   |
| Settlement Type                                   | Shows the type of settlement from the possible values:<br><input type="checkbox"/> UNIT (Units)<br><input type="checkbox"/> FAMT (Face Amount)  |
| Original Settlement Quantity                      | Shows the quantity of securities to be settled.   |

| General Statement Information |  |
|-------------------------------|--|
| Previously Settled Quantity   | Shows the quantity settled before the reporting period.  |
| Remaining Quantity            | Shows the remaining number of securities to be settled.  |
| Settled Settlement Quantity   | Shows the number of securities which was settled on the current business day/during the reporting period.          |
| Actual Settlement Date        | Shows the date of the settlement.<br>Displayed format is: YYYY-MM-DD   |
| Accepted Timestamp (SF1)      | Shows the accepted timestamp of the settlement restriction.<br>Displayed format is: YYYY-MM-DD hh:mm:ss:µsµsµsµsµs |
| Restriction Type Balance from | Shows the restriction type code of a position of the debited securities account.                                   |
| Issuer                        | Shows the entity assigning the identification. The fixed value is 'T2S'.   |
| Scheme Name                   | Shows the name of the scheme. The fixed value is 'RT' (for restriction type).                                      |
| Restriction Type Balance to   | Shows the restriction type code of a position of the credited securities account.                                  |
| Issuer                        | Shows the entity assigning the identification. The fixed value is 'T2S'.   |
| Scheme Name                   | Shows the name of the scheme. The fixed value is 'RT' (for restriction type).                                      |
| Restriction Reference         | Shows the identification of the restriction assigned by T2S.   |

### 2.4.1.19 Available Report - Statement of Settlement Allegements - Details Screen

#### Context of Usage

This screen displays detailed information on statements of settlement allegations, which provide information about the list of all settlement instructions received from other T2S actors missing a corresponding securities settlement instruction.

The report displayed in this screen has to be already created in accordance with its report configuration.

This screen is not relevant for CB and payment bank/settlement bank users.

#### Screen Access

Services >> Additional Services >> Reports >> *Available reports – search/list* screen >> Click on the *search* and/or *details* button

- Services >> Additional Services >> Reports >> **Available reports – search/list** screen >> Click on the **search** and/or **details** button >> **Available report – details** screen >> Click on the **details** button

**Privileges**

To use this screen, you need the following privilege [▶ 873]:

- Report details query

**References****User Instructions Part**

This screen is part of the following business scenario:

- View available reports

**Business Functionality Document**

This screen corresponds to the following business function:

- Display generated report details (T2S.GUI.INSE.RPT.0090)

Available Report - Statement of Settlement Allegements - Details Screen

Screenshot

| SECURITIES  | CASH  | SERVICES  | STATIC DATA | MONITORING |  |   |   |                              |                         |                    |                            |  |  |                                |  |                                  |                                 |   |               |                    |                      |                                   |  |  |                   |                   |               |               |                 |                               |  |                         |  |   |                            |                            |                              |                                  |                      |                        |                      |                         |                        |                                   |   |                                      |                           |  |                              |  |  |                                    |   |                             |  |                                     |  |                                  |  |  |                             |  |  |                                    |                             |  |   |                                     |  |                                 |  |  |
|---|---|---|-------------|------------|--|---|---|------------------------------|-------------------------|--------------------|----------------------------|--|--|--------------------------------|--|----------------------------------|---------------------------------|---|---------------|--------------------|----------------------|-----------------------------------|--|--|-------------------|-------------------|---------------|---------------|-----------------|-------------------------------|--|-------------------------|--|---|----------------------------|----------------------------|------------------------------|----------------------------------|----------------------|------------------------|----------------------|-------------------------|------------------------|-----------------------------------|---|--------------------------------------|---------------------------|--|------------------------------|--|--|------------------------------------|---|-----------------------------|--|-------------------------------------|--|----------------------------------|--|--|-----------------------------|--|--|------------------------------------|-----------------------------|--|---|-------------------------------------|--|---------------------------------|--|--|
| <p>Services &gt; Additional Services &gt; Reports &gt; Report Details &gt; Statement of Settlement Allegements</p>  |   |   |             |            |  |   |   |                              |                         |                    |                            |  |  |                                |  |                                  |                                 |   |               |                    |                      |                                   |  |  |                   |                   |               |               |                 |                               |  |                         |  |   |                            |                            |                              |                                  |                      |                        |                      |                         |                        |                                   |   |                                      |                           |  |                              |  |  |                                    |   |                             |  |                                     |  |                                  |  |  |                             |  |  |                                    |                             |  |   |                                     |  |                                 |  |  |
| <p><b>General Information</b></p> <p>General Statement Information</p> <table border="1"> <tr> <td>Report Name<br/>Statement of Settlement Allegements</td> <td>Delta Mode<br/>No</td> <td>Statement Number<br/>20210409AF00082</td> </tr> <tr> <td>Report Number<br/>1050062670</td> <td>Frequency<br/>DAIL</td> <td>Scheduled<br/>13:44</td> </tr> <tr> <td>Activity Indicator<br/>True</td> <td>Covered Period from<br/>2021-04-08 11:05:29</td> <td>Covered Period to<br/>2021-04-09 13:44:00</td> </tr> <tr> <td>Report Owner BIC<br/>CSDNLADXXX</td> <td>Report Owner Parent BIC<br/>TCSOTCS00XX</td> <td>System Entity Wide Report<br/>Yes</td> </tr> </table> <p>Party Information</p> <table border="1"> <tr> <td>Alleged Party BIC<br/>CSDNLADXXX</td> <td>Alleged Party Parent BIC<br/>TCSOTCS00XX</td> </tr> </table>   |   |   |             |            | Report Name<br>Statement of Settlement Allegements | Delta Mode<br>No                        | Statement Number<br>20210409AF00082   | Report Number<br>1050062670  | Frequency<br>DAIL       | Scheduled<br>13:44 | Activity Indicator<br>True | Covered Period from<br>2021-04-08 11:05:29 | Covered Period to<br>2021-04-09 13:44:00 | Report Owner BIC<br>CSDNLADXXX | Report Owner Parent BIC<br>TCSOTCS00XX | System Entity Wide Report<br>Yes | Alleged Party BIC<br>CSDNLADXXX | Alleged Party Parent BIC<br>TCSOTCS00XX |               |                    |                      |                                   |  |  |                   |                   |               |               |                 |                               |  |                         |  |   |                            |                            |                              |                                  |                      |                        |                      |                         |                        |                                   |   |                                      |                           |  |                              |  |  |                                    |   |                             |  |                                     |  |                                  |  |  |                             |  |  |                                    |                             |  |   |                                     |  |                                 |  |  |
| Report Name<br>Statement of Settlement Allegements  | Delta Mode<br>No                                      | Statement Number<br>20210409AF00082   |             |            |  |   |   |                              |                         |                    |                            |  |  |                                |  |                                  |                                 |   |               |                    |                      |                                   |  |  |                   |                   |               |               |                 |                               |  |                         |  |   |                            |                            |                              |                                  |                      |                        |                      |                         |                        |                                   |   |                                      |                           |  |                              |  |  |                                    |   |                             |  |                                     |  |                                  |  |  |                             |  |  |                                    |                             |  |   |                                     |  |                                 |  |  |
| Report Number<br>1050062670   | Frequency<br>DAIL                                     | Scheduled<br>13:44  |             |            |  |   |   |                              |                         |                    |                            |  |  |                                |  |                                  |                                 |   |               |                    |                      |                                   |  |  |                   |                   |               |               |                 |                               |  |                         |  |   |                            |                            |                              |                                  |                      |                        |                      |                         |                        |                                   |   |                                      |                           |  |                              |  |  |                                    |   |                             |  |                                     |  |                                  |  |  |                             |  |  |                                    |                             |  |   |                                     |  |                                 |  |  |
| Activity Indicator<br>True  | Covered Period from<br>2021-04-08 11:05:29            | Covered Period to<br>2021-04-09 13:44:00                                      |             |            |  |   |   |                              |                         |                    |                            |  |  |                                |  |                                  |                                 |   |               |                    |                      |                                   |  |  |                   |                   |               |               |                 |                               |  |                         |  |   |                            |                            |                              |                                  |                      |                        |                      |                         |                        |                                   |   |                                      |                           |  |                              |  |  |                                    |   |                             |  |                                     |  |                                  |  |  |                             |  |  |                                    |                             |  |   |                                     |  |                                 |  |  |
| Report Owner BIC<br>CSDNLADXXX  | Report Owner Parent BIC<br>TCSOTCS00XX                | System Entity Wide Report<br>Yes  |             |            |  |   |   |                              |                         |                    |                            |  |  |                                |  |                                  |                                 |   |               |                    |                      |                                   |  |  |                   |                   |               |               |                 |                               |  |                         |  |   |                            |                            |                              |                                  |                      |                        |                      |                         |                        |                                   |   |                                      |                           |  |                              |  |  |                                    |   |                             |  |                                     |  |                                  |  |  |                             |  |  |                                    |                             |  |   |                                     |  |                                 |  |  |
| Alleged Party BIC<br>CSDNLADXXX   | Alleged Party Parent BIC<br>TCSOTCS00XX               |   |             |            |  |   |   |                              |                         |                    |                            |  |  |                                |  |                                  |                                 |   |               |                    |                      |                                   |  |  |                   |                   |               |               |                 |                               |  |                         |  |   |                            |                            |                              |                                  |                      |                        |                      |                         |                        |                                   |   |                                      |                           |  |                              |  |  |                                    |   |                             |  |                                     |  |                                  |  |  |                             |  |  |                                    |                             |  |   |                                     |  |                                 |  |  |
| <p><b>Settlement Allegement 1 of 1</b></p> <p>Instruction References</p> <table border="1"> <tr> <td>Account Owner Reference<br/>Dart</td> <td>Account Servicer Reference<br/>S1020ZV01</td> <td>Unique T2S Technical Identifier of a Settlement Instruction<br/>21040800264863</td> </tr> <tr> <td>Third Party Reference<br/>---</td> <td>Common Reference<br/>---</td> <td></td> </tr> </table> <p>Allegement Status<br/>---</p> <p>Trade Timeline</p> <table border="1"> <tr> <td>Trade Date<br/>2021-04-09</td> <td>Settlement Date<br/>2021-04-09</td> </tr> </table> <p>Trade Information</p> <table border="1"> <tr> <td>Securities Movement Type<br/>DELI</td> <td>Payment Type<br/>AFMT</td> <td>Beneficial Ownership<br/>Yes</td> </tr> <tr> <td>Place of Clearing<br/>CSDNLADXXX</td> <td>Place of Trade<br/>---</td> <td>Proprietary Identification<br/>---</td> </tr> <tr> <td>Issuer<br/>---</td> <td>Schema Name<br/>---</td> <td>ISIN<br/>NLCDNL000080</td> </tr> <tr> <td>Name<br/>CSDNLADXXX / NLCDNL000080</td> <td></td> <td></td> </tr> <tr> <td>Deal Price<br/>---</td> <td>Value Type<br/>---</td> <td>Rate %<br/>---</td> </tr> <tr> <td>Amount<br/>---</td> <td>Currency<br/>---</td> <td>Number of Days Accrued<br/>---</td> </tr> <tr> <td>Settlement Quantity<br/>Settlement Quantity<br/>85000.00</td> <td>Settlement Type<br/>FAMT</td> <td></td> </tr> <tr> <td>Settlement Amount<br/>Credit Debit Indicator<br/>CRDT</td> <td>Settlement Amount<br/>85.00</td> <td>Settlement Currency<br/>EUR</td> </tr> <tr> <td>Original Ordered Amount<br/>0</td> <td>Original Ordered Currency<br/>EUR</td> <td>Unit Currency<br/>---</td> </tr> <tr> <td>Quoted Currency<br/>---</td> <td>Exchange Rate<br/>---</td> <td>Resulting Amount<br/>---</td> </tr> </table> <p>Status Information</p> <table border="1"> <tr> <td>CumEx Indicator<br/>---</td> <td>ISO Transaction Type Code<br/>TRAD</td> <td>Settlement Transaction Condition Indicator<br/>---</td> </tr> <tr> <td>Partial Settlement Indicator<br/>NPAR</td> <td>Market Client Side<br/>---</td> <td></td> </tr> </table> <p>Delivering Settlement Parties</p> <table border="1"> <tr> <td>Delivering CSD<br/>CSDNLADXXX</td> <td></td> <td></td> </tr> <tr> <td>Delivering T2S Party<br/>PMBDNLDXXX</td> <td>Delivering Party - Securities Account<br/>CSDPCDNL0007</td> <td>Declarations details<br/>DCA</td> </tr> <tr> <td>Client of the Delivering CSD Participant<br/>PMBDNLDXXX</td> <td>Safekeeping Account<br/>CSDPCDNL0005</td> <td></td> </tr> <tr> <td>Delivering Party 3<br/>PMBDNLDXXX</td> <td>Safekeeping Account<br/>SafekeepingAccount3</td> <td></td> </tr> </table> <p>Receiving Settlement Parties</p> <table border="1"> <tr> <td>Receiving CSD<br/>CSDNLADXXX</td> <td></td> <td></td> </tr> <tr> <td>Receiving T2S Party<br/>NCSDNLADXXX</td> <td>Declarations details<br/>RRR</td> <td></td> </tr> <tr> <td>Client of the Delivering CSD Participant<br/>NCSDNLADXXX</td> <td>Safekeeping Account<br/>CSDPCDNL0014</td> <td></td> </tr> <tr> <td>Receiving Party 3<br/>PMBDNLDXXX</td> <td>Safekeeping Account<br/>SafekeepingAccount3</td> <td></td> </tr> </table> |   |   |             |            | Account Owner Reference<br>Dart                    | Account Servicer Reference<br>S1020ZV01 | Unique T2S Technical Identifier of a Settlement Instruction<br>21040800264863 | Third Party Reference<br>--- | Common Reference<br>--- |                    | Trade Date<br>2021-04-09   | Settlement Date<br>2021-04-09              | Securities Movement Type<br>DELI         | Payment Type<br>AFMT           | Beneficial Ownership<br>Yes            | Place of Clearing<br>CSDNLADXXX  | Place of Trade<br>---           | Proprietary Identification<br>---       | Issuer<br>--- | Schema Name<br>--- | ISIN<br>NLCDNL000080 | Name<br>CSDNLADXXX / NLCDNL000080 |  |  | Deal Price<br>--- | Value Type<br>--- | Rate %<br>--- | Amount<br>--- | Currency<br>--- | Number of Days Accrued<br>--- | Settlement Quantity<br>Settlement Quantity<br>85000.00 | Settlement Type<br>FAMT |  | Settlement Amount<br>Credit Debit Indicator<br>CRDT | Settlement Amount<br>85.00 | Settlement Currency<br>EUR | Original Ordered Amount<br>0 | Original Ordered Currency<br>EUR | Unit Currency<br>--- | Quoted Currency<br>--- | Exchange Rate<br>--- | Resulting Amount<br>--- | CumEx Indicator<br>--- | ISO Transaction Type Code<br>TRAD | Settlement Transaction Condition Indicator<br>--- | Partial Settlement Indicator<br>NPAR | Market Client Side<br>--- |  | Delivering CSD<br>CSDNLADXXX |  |  | Delivering T2S Party<br>PMBDNLDXXX | Delivering Party - Securities Account<br>CSDPCDNL0007 | Declarations details<br>DCA | Client of the Delivering CSD Participant<br>PMBDNLDXXX | Safekeeping Account<br>CSDPCDNL0005 |  | Delivering Party 3<br>PMBDNLDXXX | Safekeeping Account<br>SafekeepingAccount3 |  | Receiving CSD<br>CSDNLADXXX |  |  | Receiving T2S Party<br>NCSDNLADXXX | Declarations details<br>RRR |  | Client of the Delivering CSD Participant<br>NCSDNLADXXX | Safekeeping Account<br>CSDPCDNL0014 |  | Receiving Party 3<br>PMBDNLDXXX | Safekeeping Account<br>SafekeepingAccount3 |  |
| Account Owner Reference<br>Dart   | Account Servicer Reference<br>S1020ZV01               | Unique T2S Technical Identifier of a Settlement Instruction<br>21040800264863 |             |            |  |   |   |                              |                         |                    |                            |  |  |                                |  |                                  |                                 |   |               |                    |                      |                                   |  |  |                   |                   |               |               |                 |                               |  |                         |  |   |                            |                            |                              |                                  |                      |                        |                      |                         |                        |                                   |   |                                      |                           |  |                              |  |  |                                    |   |                             |  |                                     |  |                                  |  |  |                             |  |  |                                    |                             |  |   |                                     |  |                                 |  |  |
| Third Party Reference<br>---  | Common Reference<br>---                               |   |             |            |  |   |   |                              |                         |                    |                            |  |  |                                |  |                                  |                                 |   |               |                    |                      |                                   |  |  |                   |                   |               |               |                 |                               |  |                         |  |   |                            |                            |                              |                                  |                      |                        |                      |                         |                        |                                   |   |                                      |                           |  |                              |  |  |                                    |   |                             |  |                                     |  |                                  |  |  |                             |  |  |                                    |                             |  |   |                                     |  |                                 |  |  |
| Trade Date<br>2021-04-09  | Settlement Date<br>2021-04-09                         |   |             |            |  |   |   |                              |                         |                    |                            |  |  |                                |  |                                  |                                 |   |               |                    |                      |                                   |  |  |                   |                   |               |               |                 |                               |  |                         |  |   |                            |                            |                              |                                  |                      |                        |                      |                         |                        |                                   |   |                                      |                           |  |                              |  |  |                                    |   |                             |  |                                     |  |                                  |  |  |                             |  |  |                                    |                             |  |   |                                     |  |                                 |  |  |
| Securities Movement Type<br>DELI  | Payment Type<br>AFMT                                  | Beneficial Ownership<br>Yes   |             |            |  |   |   |                              |                         |                    |                            |  |  |                                |  |                                  |                                 |   |               |                    |                      |                                   |  |  |                   |                   |               |               |                 |                               |  |                         |  |   |                            |                            |                              |                                  |                      |                        |                      |                         |                        |                                   |   |                                      |                           |  |                              |  |  |                                    |   |                             |  |                                     |  |                                  |  |  |                             |  |  |                                    |                             |  |   |                                     |  |                                 |  |  |
| Place of Clearing<br>CSDNLADXXX   | Place of Trade<br>---                                 | Proprietary Identification<br>---   |             |            |  |   |   |                              |                         |                    |                            |  |  |                                |  |                                  |                                 |   |               |                    |                      |                                   |  |  |                   |                   |               |               |                 |                               |  |                         |  |   |                            |                            |                              |                                  |                      |                        |                      |                         |                        |                                   |   |                                      |                           |  |                              |  |  |                                    |   |                             |  |                                     |  |                                  |  |  |                             |  |  |                                    |                             |  |   |                                     |  |                                 |  |  |
| Issuer<br>---   | Schema Name<br>---                                    | ISIN<br>NLCDNL000080  |             |            |  |   |   |                              |                         |                    |                            |  |  |                                |  |                                  |                                 |   |               |                    |                      |                                   |  |  |                   |                   |               |               |                 |                               |  |                         |  |   |                            |                            |                              |                                  |                      |                        |                      |                         |                        |                                   |   |                                      |                           |  |                              |  |  |                                    |   |                             |  |                                     |  |                                  |  |  |                             |  |  |                                    |                             |  |   |                                     |  |                                 |  |  |
| Name<br>CSDNLADXXX / NLCDNL000080   |   |   |             |            |  |   |   |                              |                         |                    |                            |  |  |                                |  |                                  |                                 |   |               |                    |                      |                                   |  |  |                   |                   |               |               |                 |                               |  |                         |  |   |                            |                            |                              |                                  |                      |                        |                      |                         |                        |                                   |   |                                      |                           |  |                              |  |  |                                    |   |                             |  |                                     |  |                                  |  |  |                             |  |  |                                    |                             |  |   |                                     |  |                                 |  |  |
| Deal Price<br>---   | Value Type<br>---                                     | Rate %<br>---   |             |            |  |   |   |                              |                         |                    |                            |  |  |                                |  |                                  |                                 |   |               |                    |                      |                                   |  |  |                   |                   |               |               |                 |                               |  |                         |  |   |                            |                            |                              |                                  |                      |                        |                      |                         |                        |                                   |   |                                      |                           |  |                              |  |  |                                    |   |                             |  |                                     |  |                                  |  |  |                             |  |  |                                    |                             |  |   |                                     |  |                                 |  |  |
| Amount<br>---   | Currency<br>---                                       | Number of Days Accrued<br>---   |             |            |  |   |   |                              |                         |                    |                            |  |  |                                |  |                                  |                                 |   |               |                    |                      |                                   |  |  |                   |                   |               |               |                 |                               |  |                         |  |   |                            |                            |                              |                                  |                      |                        |                      |                         |                        |                                   |   |                                      |                           |  |                              |  |  |                                    |   |                             |  |                                     |  |                                  |  |  |                             |  |  |                                    |                             |  |   |                                     |  |                                 |  |  |
| Settlement Quantity<br>Settlement Quantity<br>85000.00  | Settlement Type<br>FAMT                               |   |             |            |  |   |   |                              |                         |                    |                            |  |  |                                |  |                                  |                                 |   |               |                    |                      |                                   |  |  |                   |                   |               |               |                 |                               |  |                         |  |   |                            |                            |                              |                                  |                      |                        |                      |                         |                        |                                   |   |                                      |                           |  |                              |  |  |                                    |   |                             |  |                                     |  |                                  |  |  |                             |  |  |                                    |                             |  |   |                                     |  |                                 |  |  |
| Settlement Amount<br>Credit Debit Indicator<br>CRDT   | Settlement Amount<br>85.00                            | Settlement Currency<br>EUR  |             |            |  |   |   |                              |                         |                    |                            |  |  |                                |  |                                  |                                 |   |               |                    |                      |                                   |  |  |                   |                   |               |               |                 |                               |  |                         |  |   |                            |                            |                              |                                  |                      |                        |                      |                         |                        |                                   |   |                                      |                           |  |                              |  |  |                                    |   |                             |  |                                     |  |                                  |  |  |                             |  |  |                                    |                             |  |   |                                     |  |                                 |  |  |
| Original Ordered Amount<br>0  | Original Ordered Currency<br>EUR                      | Unit Currency<br>---  |             |            |  |   |   |                              |                         |                    |                            |  |  |                                |  |                                  |                                 |   |               |                    |                      |                                   |  |  |                   |                   |               |               |                 |                               |  |                         |  |   |                            |                            |                              |                                  |                      |                        |                      |                         |                        |                                   |   |                                      |                           |  |                              |  |  |                                    |   |                             |  |                                     |  |                                  |  |  |                             |  |  |                                    |                             |  |   |                                     |  |                                 |  |  |
| Quoted Currency<br>---  | Exchange Rate<br>---                                  | Resulting Amount<br>---   |             |            |  |   |   |                              |                         |                    |                            |  |  |                                |  |                                  |                                 |   |               |                    |                      |                                   |  |  |                   |                   |               |               |                 |                               |  |                         |  |   |                            |                            |                              |                                  |                      |                        |                      |                         |                        |                                   |   |                                      |                           |  |                              |  |  |                                    |   |                             |  |                                     |  |                                  |  |  |                             |  |  |                                    |                             |  |   |                                     |  |                                 |  |  |
| CumEx Indicator<br>---  | ISO Transaction Type Code<br>TRAD                     | Settlement Transaction Condition Indicator<br>---                             |             |            |  |   |   |                              |                         |                    |                            |  |  |                                |  |                                  |                                 |   |               |                    |                      |                                   |  |  |                   |                   |               |               |                 |                               |  |                         |  |   |                            |                            |                              |                                  |                      |                        |                      |                         |                        |                                   |   |                                      |                           |  |                              |  |  |                                    |   |                             |  |                                     |  |                                  |  |  |                             |  |  |                                    |                             |  |   |                                     |  |                                 |  |  |
| Partial Settlement Indicator<br>NPAR  | Market Client Side<br>---                             |   |             |            |  |   |   |                              |                         |                    |                            |  |  |                                |  |                                  |                                 |   |               |                    |                      |                                   |  |  |                   |                   |               |               |                 |                               |  |                         |  |   |                            |                            |                              |                                  |                      |                        |                      |                         |                        |                                   |   |                                      |                           |  |                              |  |  |                                    |   |                             |  |                                     |  |                                  |  |  |                             |  |  |                                    |                             |  |   |                                     |  |                                 |  |  |
| Delivering CSD<br>CSDNLADXXX  |   |   |             |            |  |   |   |                              |                         |                    |                            |  |  |                                |  |                                  |                                 |   |               |                    |                      |                                   |  |  |                   |                   |               |               |                 |                               |  |                         |  |   |                            |                            |                              |                                  |                      |                        |                      |                         |                        |                                   |   |                                      |                           |  |                              |  |  |                                    |   |                             |  |                                     |  |                                  |  |  |                             |  |  |                                    |                             |  |   |                                     |  |                                 |  |  |
| Delivering T2S Party<br>PMBDNLDXXX  | Delivering Party - Securities Account<br>CSDPCDNL0007 | Declarations details<br>DCA   |             |            |  |   |   |                              |                         |                    |                            |  |  |                                |  |                                  |                                 |   |               |                    |                      |                                   |  |  |                   |                   |               |               |                 |                               |  |                         |  |   |                            |                            |                              |                                  |                      |                        |                      |                         |                        |                                   |   |                                      |                           |  |                              |  |  |                                    |   |                             |  |                                     |  |                                  |  |  |                             |  |  |                                    |                             |  |   |                                     |  |                                 |  |  |
| Client of the Delivering CSD Participant<br>PMBDNLDXXX  | Safekeeping Account<br>CSDPCDNL0005                   |   |             |            |  |   |   |                              |                         |                    |                            |  |  |                                |  |                                  |                                 |   |               |                    |                      |                                   |  |  |                   |                   |               |               |                 |                               |  |                         |  |   |                            |                            |                              |                                  |                      |                        |                      |                         |                        |                                   |   |                                      |                           |  |                              |  |  |                                    |   |                             |  |                                     |  |                                  |  |  |                             |  |  |                                    |                             |  |   |                                     |  |                                 |  |  |
| Delivering Party 3<br>PMBDNLDXXX  | Safekeeping Account<br>SafekeepingAccount3            |   |             |            |  |   |   |                              |                         |                    |                            |  |  |                                |  |                                  |                                 |   |               |                    |                      |                                   |  |  |                   |                   |               |               |                 |                               |  |                         |  |   |                            |                            |                              |                                  |                      |                        |                      |                         |                        |                                   |   |                                      |                           |  |                              |  |  |                                    |   |                             |  |                                     |  |                                  |  |  |                             |  |  |                                    |                             |  |   |                                     |  |                                 |  |  |
| Receiving CSD<br>CSDNLADXXX   |   |   |             |            |  |   |   |                              |                         |                    |                            |  |  |                                |  |                                  |                                 |   |               |                    |                      |                                   |  |  |                   |                   |               |               |                 |                               |  |                         |  |   |                            |                            |                              |                                  |                      |                        |                      |                         |                        |                                   |   |                                      |                           |  |                              |  |  |                                    |   |                             |  |                                     |  |                                  |  |  |                             |  |  |                                    |                             |  |   |                                     |  |                                 |  |  |
| Receiving T2S Party<br>NCSDNLADXXX  | Declarations details<br>RRR                           |   |             |            |  |   |   |                              |                         |                    |                            |  |  |                                |  |                                  |                                 |   |               |                    |                      |                                   |  |  |                   |                   |               |               |                 |                               |  |                         |  |   |                            |                            |                              |                                  |                      |                        |                      |                         |                        |                                   |   |                                      |                           |  |                              |  |  |                                    |   |                             |  |                                     |  |                                  |  |  |                             |  |  |                                    |                             |  |   |                                     |  |                                 |  |  |
| Client of the Delivering CSD Participant<br>NCSDNLADXXX   | Safekeeping Account<br>CSDPCDNL0014                   |   |             |            |  |   |   |                              |                         |                    |                            |  |  |                                |  |                                  |                                 |   |               |                    |                      |                                   |  |  |                   |                   |               |               |                 |                               |  |                         |  |   |                            |                            |                              |                                  |                      |                        |                      |                         |                        |                                   |   |                                      |                           |  |                              |  |  |                                    |   |                             |  |                                     |  |                                  |  |  |                             |  |  |                                    |                             |  |   |                                     |  |                                 |  |  |
| Receiving Party 3<br>PMBDNLDXXX   | Safekeeping Account<br>SafekeepingAccount3            |   |             |            |  |   |   |                              |                         |                    |                            |  |  |                                |  |                                  |                                 |   |               |                    |                      |                                   |  |  |                   |                   |               |               |                 |                               |  |                         |  |   |                            |                            |                              |                                  |                      |                        |                      |                         |                        |                                   |   |                                      |                           |  |                              |  |  |                                    |   |                             |  |                                     |  |                                  |  |  |                             |  |  |                                    |                             |  |   |                                     |  |                                 |  |  |

Illustration 111: Available report - statement of settlement allegements - details screen

Field Descriptions

| General Statement Information       |  |
|-------------------------------------|--|
| Statement of Settlement Allegements |  |
| Report Name                         | Shows the name of the report.                                      |
| Delta Mode                          | Shows if the report is a delta report or not. Possible values are: |



| General Statement Information |   |
|-------------------------------|---|
|                               | <input type="checkbox"/> Yes<br><input type="checkbox"/> No   |
| Statement Number              | <p>Shows the statement number of the report composed of the business date and report type (2-letter abbreviation depending on report type and Delta/Full-Flag) and the sequential number, which is unique in T2S.</p> <p>The number increases for each report.</p>              |
| Report Number                 | <p>Shows the sequential number of the report which is specific for a report receiving party.</p> <p>This number will only be displayed if the sending user belongs to a report receiving party.</p>   |
| Frequency                     | Shows the frequency of the report, which is always 'DAILY'.   |
| Scheduled                     | Shows the name of the business event or time triggering the report creation.  |
| Activity Indicator            | <p>Shows whether the report displays activities or only lists information from the possible values:</p> <input type="checkbox"/> True<br><input type="checkbox"/> False   |
| Covered Period from           | <p>Shows the date and time from which the data are covered in the report.</p> <p>Displayed format is: YYYY-MM-DD hh:mm:ss</p>   |
| Covered Period to             | <p>Shows the date and time until which the data are covered in the report.</p> <p>Displayed format is: YYYY-MM-DD hh:mm:ss</p>  |
| System Entity Wide Report     | <p>Shows whether the report is a community report (covering all information referring to a system entity) or a party based report (covering all information referring to a party) from the possible values:</p> <input type="checkbox"/> True<br><input type="checkbox"/> False |
| Report Owner BIC              | Shows the party BIC of the report owner.  |
| Report Owner Parent BIC       | Shows the parent BIC of the report owner.   |
| Allegement Details            |   |

| General Statement Information   |   |
|---------------------------------|---|
| Instruction References          |   |
| Account Owner Reference         | Shows the identification of the transaction that could potentially match with the notified allegation.  |
| Account Servicer Reference      | Shows the identification of the transaction assigned by the CSD.<br><br>This field is optional.   |
| Allegation Technical Identifier | Shows the identification of the transaction assigned by T2S.  |
| Third Party Reference           | Shows the identification of the instruction assigned by a third party.<br><br>This field is optional.   |
| Trade Identification            | Shows the identification of the trade assigned by the investor or the trading party.<br><br>This reference is used throughout the trade life cycle to access or update the trade details.<br><br>This field is optional and repetitive. |
| Common Reference                | Shows the identification the 2 trade counterparties agreed in order to identify the trade. This field is optional.  |
| Allegation Status               |   |
| Allegation Status               | Shows the status of the allegation from the possible values:<br><br><input type="checkbox"/> Sent (default value)<br><input type="checkbox"/> Removed<br><input type="checkbox"/> Cancelled   |
| Trade Timeline                  |   |
| Trade Date                      | Shows the date when the contract was made.<br><br>Displayed format is: YYYY-MM-DD   |
| Settlement Date                 | Shows the date when the securities are to be delivered or received.<br><br>Displayed format is: YYYY-MM-DD  |
| Trade Information               |   |
| Securities Movement Type Code   | Shows the movement on a securities account from the possible values:<br><br><input type="checkbox"/> DELI (for delivery)  |

| General Statement Information |  |
|-------------------------------|--|
|                               | <input type="checkbox"/> RECE (for receive)  |
| Payment Type                  | Shows the type of the payment from the possible values:<br><input type="checkbox"/> APMT (for against payment settlement)<br><input type="checkbox"/> FREE (for separate settlement)   |
| Beneficial Ownership          | Shows if there is a change of beneficial ownership<br><input type="checkbox"/> No<br><input type="checkbox"/> Yes  |
| Place of Trade Identifier     | Shows the identification of the place of trade via the market identifier code.<br><br>Either this field or the description of the place of trade is available.   |
| Place of Clearing             | Shows the BIC code of the Clearing House involved in the settlement (if any).  |
| Description                   | Shows the description of the place of trade.<br><br>Either this field or the MIC Id is available.  |
| Type Code                     | Shows the market type code from the possible values:<br><input type="checkbox"/> EXCH (for stock exchange)<br><input type="checkbox"/> OTCO (for over the counter)<br><input type="checkbox"/> PRIM (for primary market)<br><input type="checkbox"/> SECM (for secondary market)<br><input type="checkbox"/> VARI (for various)<br><br>Either this field or the proprietary identification of the place of trade in addition to the issuer and scheme name is available. |
| Proprietary Identification    | Shows the proprietary identification of the allegation assigned by the issuer of the data source scheme.<br><br>Either this field in addition to the issuer and scheme name or the code of the place of trade is available.  |
| Issuer                        | Shows the issuer of the proprietary identification.<br><br>Either this field in addition to the proprietary identification and scheme name or the code of the place of trade is available.   |
| Scheme Name                   | Shows the description of the data source scheme.   |

| General Statement Information |   |
|-------------------------------|---|
|                               | Either this field in addition to the proprietary identification and the issuer or the code of the place of trade is available.                                      |
| ISIN                          | Shows the ISIN of the security.   |
| Securities Name               | Shows the name of the security.   |
| Deal Price - Yielded          | Shows whether the price is expressed as a yield from the possible values:<br><input type="checkbox"/> Yes<br><input type="checkbox"/> No<br>This field is optional. |
| Deal Price – Value Type       | Shows the type of the value in which the price is expressed.<br>This field is optional and only filled in if the deal price is not expressed as a yield.            |
| Deal Price – Rate %           | Shows the price expressed as a rate.<br>This field is optional.   |
| Deal Price - Amount           | Shows price expressed as the value of the security.<br>This field is optional.  |
| Deal Price - Currency         | Shows the currency of the security.<br>This field is optional.  |
| Number of Days Accrued        | Shows the number of days on which the interest rate accrues.<br>This field is optional.   |
| Settlement Quantity           |   |
| Settlement Quantity           | Shows the quantity of the security to be settled.   |
| Settlement Type               | Shows the type of settlement from the possible values:<br><input type="checkbox"/> UNIT (Units)<br><input type="checkbox"/> FAMT (Face Amount)                      |
| Settlement Amount             |   |
| Debit Credit Indicator        | Shows if an operation is a credit or a debit from the possible values:<br><input type="checkbox"/> CRDT (for credit)<br><input type="checkbox"/> DBIT (for debit)   |

| General Statement Information                          |  |
|--|--|
| Settlement Amount                                      | Shows the amount to be paid or received in exchange for the securities.  |
| Settlement Currency                                    | Shows the currency of the settlement.  |
| Original Ordered Amount                                | Shows the posting or settlement amount in its original currency.<br><br>This field is only available, if a conversion from/into another currency has occurred.                                 |
| Original Ordered Currency                              | Shows the currency of the original ordered amount.<br><br>This field is only available, if a conversion from/into another currency has occurred.   |
| Unit Currency  | Shows the currency in which the rate of exchange is expressed in a currency exchange.<br><br>This field is optional.   |
| Quoted Currency  | Shows the currency into which the base currency is converted in a currency exchange.<br><br>This field is optional.  |
| Exchange Rate  | Shows the factor used for the conversion of an amount from 1 currency into another reflecting the price at which the currency was bought with another currency.<br><br>This field is optional. |
| Resulting Amount                                       | Shows the value and currency after a currency conversion.<br><br>This field is optional.   |
| Settlement Parameters                                  |  |
| CUM/EX Indicator                                       | Shows if a security is traded with or without coupon from the possible values:<br><br><input type="checkbox"/> CUM (for cum coupon)<br><input type="checkbox"/> EX (for ex coupon)             |
| ISO Transaction Type Code                              | Shows the ISO 20022 code of the securities transaction type. For details please see UDFS chapter 4.2.1.  |
| Opt-Out ISO Settlement Transaction Condition Indicator | Shows the conditions under which the order/trade is to be settled.   |
| Partial Settlement Indicator                           | Shows if the settlement instruction is allowed to be subject to partial settlement from the possible values:<br><br><input type="checkbox"/> NPAR (for no partial settlement allowed)          |

| <b>General Statement Information</b>            |  |
|---|--|
|   | <input type="checkbox"/> PART (for partial settlement allowed without restrictions)<br><input type="checkbox"/> PARC (for partial settlement allowed but the settlement amount must not be below the threshold)<br><input type="checkbox"/> PARQ (for partial settlement allowed but the quantity must not be below the threshold) |
| Market Client Side                              | Shows the market or client side information as an ISO 20022 code from the possible values:<br><input type="checkbox"/> CLNT (for client side)<br><input type="checkbox"/> MAKT (for market side)   |
| <b>Settlement Parties</b>                       |  |
| <b>Delivering Parties</b>                       |  |
| <b>Delivering Depository</b>                    |  |
| Party BIC                                       | Shows the BIC of the CSD delivering the securities.  |
| Processing Identification                       | Shows the reference of the instruction assigned by the delivering depository.<br>This field is optional.   |
| <b>Delivering CSD Participant</b>               |  |
| Party BIC                                       | Shows the BIC of the delivering CSD participant.   |
| Securities Account Number                       | Shows the securities account number of the delivering CSD participant.<br>This field is optional.  |
| Processing Identification                       | Shows the reference of the instruction assigned by the delivering CSD participant.<br>This field is optional.  |
| Contact Details                                 | Shows the contact details of the delivering CSD participant. This field is optional.   |
| Declaration Details                             | Provides declaration details narrative relative to the party.  |
| <b>Client of the Delivering CSD Participant</b> |  |
| Party BIC                                       | Shows the client of the delivering CSD participant BIC.<br>This field is optional.   |
| Identification                                  | Shows the unique and unambiguous identifier, as assigned to a financial institution using a proprietary identification scheme.   |

| General Statement Information |   |
|-------------------------------|---|
|                               | This field is optional.   |
| Issuer                        | Shows the name of the issuer of the proprietary identifier.<br>This field is optional.                                    |
| Scheme Name                   | Shows the name of the scheme.<br>This field is optional.  |
| Name                          | Shows the name and address of the client.<br>This field is optional.  |
| Processing Identification     | Shows the unambiguous identification of the transaction for the party identified.<br>This field is optional.              |
| Contact Details               | Shows the contact details of the client.<br>This field is optional.   |
| Safekeeping Account           | Account to or from which a securities entry is made.  |
| Delivering Party 3            |   |
| Party BIC                     | Shows the BIC of the delivering party 3.<br>This field is conditional.  |
| Identification                | Shows the identification of the processing provided by the party.<br>This field is conditional.                           |
| Issuer                        | Shows the entity that assigns the identification.<br>This field is conditional.   |
| Scheme Name                   | Shows the name of the scheme.<br>This field is conditional.   |
| Name                          | Shows the name of the delivering party 3.<br>This field is conditional.   |
| Identification                | Shows the unambiguous identification of the transaction for the delivering party 3 identified.<br>This field is optional. |
| Contact Details               | Shows the contact details of the delivering party 3.<br>This field is optional.   |
| Safekeeping Account           | Account to or from which a securities entry is made.  |

| General Statement Information |   |
|-------------------------------|---|
| <b>Delivering Party 4</b>     |   |
| Party BIC                     | Shows the BIC of the delivering party 4.<br>This field is conditional.  |
| Identification                | Shows the identification of the processing provided by the party.<br>This field is conditional.                           |
| Issuer                        | Shows the entity that assigns the identification.<br>This field is conditional.   |
| Scheme Name                   | Shows the name of the scheme.<br>This field is conditional.   |
| Name                          | Shows the name of the delivering party 4.<br>This field is conditional.   |
| Identification                | Shows the unambiguous identification of the transaction for the delivering party 4 identified.<br>This field is optional. |
| Contact Details               | Shows the contact details of the delivering party 4.<br>This field is optional.   |
| <b>Delivering Party 5</b>     |   |
| Party BIC                     | Shows the BIC of the delivering party 5.<br>This field is conditional.  |
| Identification                | Shows the identification of the processing provided by the party.<br>This field is conditional.                           |
| Issuer                        | Shows the entity that assigns the identification.<br>This field is conditional.   |
| Scheme Name                   | Shows the name of the scheme.<br>This field is conditional.   |
| Name                          | Shows the name of the delivering party 5.<br>This field is conditional.   |
| Identification                | Shows the unambiguous identification of the transaction for the delivering party 5 identified.<br>This field is optional. |
| Contact Details               | Shows the contact details of the delivering party 5.  |



| <b>General Statement Information</b>           |   |
|--|---|
|  | This field is optional.   |
| <b>Settlement Parties</b>                      |   |
| <b>Receiving Parties</b>                       |   |
| <b>Receiving Depository</b>                    |   |
| Party BIC                                      | Shows the BIC of the CSD receiving the securities.  |
| Processing Identification                      | Shows the reference of the instruction assigned by the receiving depository.<br>This field is optional.   |
| <b>Receiving CSD Participant</b>               |   |
| Party BIC                                      | Shows the BIC of the receiving CSD participant.   |
| Securities Account Number                      | Shows the securities account number of the receiving CSD participant.<br>This field is optional.  |
| Processing Identification                      | Shows the reference of the instruction assigned by the receiving CSD participant.<br>This field is optional.  |
| Contact Details                                | Shows the contact details of the receiving CSD participant.<br>This field is optional.  |
| Declaration Details                            | Provides declaration details narrative relative to the party.   |
| <b>Client of the Receiving CSD Participant</b> |   |
| Party BIC                                      | Shows the client of the receiving CSD participant BIC.<br>This field is optional.   |
| Identification                                 | Shows the unique and unambiguous identifier, as assigned to a financial institution using a proprietary identification scheme.<br>This field is optional. |
| Issuer   | Shows the name of the issuer of the proprietary identifier.<br>This field is optional.  |
| Scheme Name                                    | Shows the name of the scheme.<br>This field is optional.  |
| Name   | Shows the name and address of the client.<br>This field is optional.  |
| Processing Identification                      | Shows the unambiguous identification of the transaction for the party identified.   |

| General Statement Information |  |
|-------------------------------|--|
|                               | This field is optional.  |
| Contact Details               | Shows the contact details of the client.<br>This field is optional.  |
| Safekeeping Account           | Account to or from which a securities entry is made.   |
| Receiving Party 3             |  |
| Party BIC                     | Shows the BIC of the receiving party 3.<br>This field is conditional.  |
| Identification                | Shows the identification of the processing provided by the party.<br>This field is conditional.                          |
| Issuer                        | Shows the entity that assigns the identification.<br>This field is conditional.  |
| Scheme Name                   | Shows the name of the scheme.<br>This field is conditional.  |
| Name                          | Shows the name of the receiving party 3.<br>This field is conditional.   |
| Identification                | Shows the unambiguous identification of the transaction for the receiving party 3 identified.<br>This field is optional. |
| Contact Details               | Shows the contact details of the receiving party 3.<br>This field is optional.   |
| Safekeeping Account           | Account to or from which a securities entry is made.   |
| Receiving Party 4             |  |
| Party BIC                     | Shows the BIC of the receiving party 4.<br>This field is conditional.  |
| Identification                | Shows the identification of the processing provided by the party.<br>This field is conditional.                          |
| Issuer                        | Shows the entity that assigns the identification.<br>This field is conditional.  |
| Scheme Name                   | Shows the name of the scheme.  |

| General Statement Information |  |
|-------------------------------|--|
|                               | This field is conditional.   |
| Name                          | Shows the name of the receiving party 4.<br>This field is conditional.   |
| Identification                | Shows the unambiguous identification of the transaction for the receiving party 4 identified.<br>This field is optional. |
| Contact Details               | Shows the contact details of the receiving party 4.<br>This field is optional.   |
| Receiving Party 5             |  |
| Party BIC                     | Shows the BIC of the receiving party 5.<br>This field is conditional.  |
| Identification                | Shows the identification of the processing provided by the party.<br>This field is conditional.                          |
| Issuer                        | Shows the entity that assigns the identification.<br>This field is conditional.  |
| Scheme Name                   | Shows the name of the scheme.<br>This field is conditional.  |
| Name                          | Shows the name of the receiving party 5.<br>This field is conditional.   |
| Identification                | Shows the unambiguous identification of the transaction for the receiving party 5 identified.<br>This field is optional. |
| Contact Details               | Shows the contact details of the receiving party 5.<br>This field is optional.   |

## 2.4.1.20 Available Report - Statement of Transactions - Details Screen

### Context of Usage

This screen displays detailed information on the selected statement of transactions. No new report will be created by entering this screen. The report will be shown in a new window. The report displayed in this screen has to be already created in accordance with its report configuration.

For large reports the user has the option to view them in portions of up to 500 transactions. Only the current portion of the report will be available for a download or print.

This screen is not relevant for CB and payment bank/settlement bank users.

**Screen  
Access**

Services >> Additional Services >> Reports >> *Available reports – search/list* screen >> Click on the *search* and/or *details* button >> *Available report – details* screen >> Click on the *details* button

**Privileges**

To use this screen, you need the following privilege [[▶ 874](#)]:

Report details query

**References****User Instructions Part**

This screen is part of the following business scenario:

View available reports

**Business Functionality Document**

This screen corresponds to the following business function:

Display generated report details (T2S.GUI.INSE.RPT.0090)

Screenshot

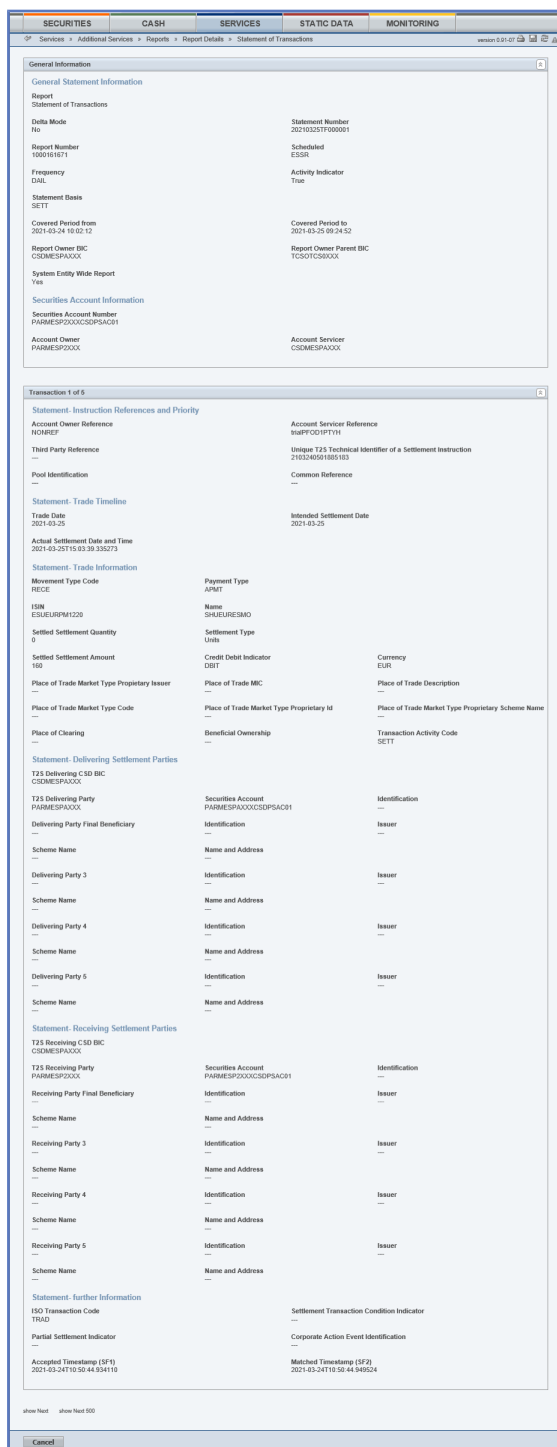

Illustration 112: Available report - statement of transactions - details screen

Field Descriptions

| General Statement Information |  |
|-------------------------------|--|
| Report Name                   | Shows the name of the report.  |
| Delta Mode                    | Shows if the report is a delta report or not. Possible values are:<br><input type="checkbox"/> Yes |

| General Statement Information |   |
|-------------------------------|---|
|                               | <input type="checkbox"/> No   |
| Statement Number              | Shows the statement number of the report composed of the business date and report type (2-letter abbreviation depending on report type and Delta/Full-Flag) and the sequential number, which is unique in T2S.<br><br>The number increases for each report. |
| Report Number                 | Shows the sequential number of the report which is specific for a report receiving party.<br><br>This number will only be displayed if the sending user belongs to a report receiving party.  |
| Scheduled                     | Shows the name of the business event or time triggering the report creation.  |
| Frequency                     | Shows the frequency of the report, which is always 'DAILY'.   |
| Statement Basis               | Shows the basis of the statement from the possible value:<br><br><input type="checkbox"/> SETT (for settled)<br><br>The statement basis is a mandatory field in the message. The ISO message allows several possible values, but T2S allows only 'SETT'.    |
| Activity Indicator            | Shows whether the report displays activities or only lists information from the possible values:<br><br><input type="checkbox"/> True<br><br><input type="checkbox"/> False   |
| Covered Period from           | Shows the date and time from which the data are covered in the report.<br><br>Displayed format is: YYYY-MM-DD hh:mm:ss  |
| Covered Period to             | Shows the date and time until which the data are covered in the report.<br><br>Displayed format is: YYYY-MM-DD hh:mm:ss   |
| Report Owner BIC              | Shows the BIC whose data is reported on   |
| Report Owner Parent BIC       | Shows the Parent BIC whose data is reported on  |
| System Entity Wide Report     | Shows whether the report is a community report (covering all information referring to a system entity) or a party based report (covering all information referring to a party) from the possible values:  |

| General Statement Information                   |   |
|---|---|
|   | <input type="checkbox"/> Yes<br><input type="checkbox"/> No   |
| Securities Account Information                  |   |
| Securities Account Number                       | Shows the number of the securities account on which the report is based.  |
| Securities Account Owner BIC                    | Shows the BIC of the party owning the securities account.   |
| Securities account Servicer BIC                 | Shows the BIC of the party operating the securities account.  |
| Transaction                                     |   |
| Statement - Instruction References and Priority |   |
| Account Owner Reference                         | Shows the identification of the instruction assigned by the T2S delivering/receiving party.                           |
| Account Servicer Reference                      | Shows the identification of the transaction assigned by the CSD.  |
| Third Party Reference                           | Shows the identification of the instruction assigned by a third party.  |
| Settlement Instruction Technical Identifier     | Shows the identification of the instruction assigned by T2S.  |
| Pool Instruction Reference                      | Shows the identification of a pool of settlement instructions or settlement restrictions.                             |
| Common Reference                                | Shows the identification the 2 trade counterparties agreed in order to identify the trade. This field is optional.    |
| Statement - Trade Timeline                      |   |
| Trade Date                                      | Shows the date when the contract was made.<br>Displayed format is: YYYY-MM-DD   |
| Intended Settlement Date                        | Shows the date when the instruction is forwarded to settlement for the first time.<br>Displayed format is: YYYY-MM-DD |
| Actual Settlement Date                          | Shows the date of the settlement.<br>Displayed format is: YY-MM-DD  |
| Accepted Timestamp (SF1)                        | Shows the accepted timestamp of the settlement instruction.<br>Displayed format is: YYYY-MM-DD hh:mm:ss:µsµsµsµsµsµs  |

| General Statement Information                         |  |
|---|--|
| Matched Timestamp (SF2)                               | Shows the matched timestamp of the settlement instruction.<br>Displayed format is: YYYY-MM-DD hh:mm:ss:μsμsμsμsμs  |
| Statement - Trade Information                         |  |
| Movement Type Code                                    | Shows the type of the movement on a securities account from the possible values:<br><input type="checkbox"/> DELI (for delivery)<br><input type="checkbox"/> RECE (for receive)      |
| Payment Type  | Shows the type of the payment from the possible values:<br><input type="checkbox"/> APMT (for against payment settlement)<br><input type="checkbox"/> FREE (for separate settlement) |
| ISIN  | Shows the ISIN of the security.  |
| Securities Name                                       | Shows the name of the security.  |
| Settled Settlement Quantity                           | Shows the settled settlement quantity which was settled on the current business day/during the reporting period.   |
| Settlement Type                                       | Shows the type of settlement from the possible values:<br><input type="checkbox"/> UNIT (Units)<br><input type="checkbox"/> FAMT (Face Amount)                                       |
| Settled Settlement Amount                             | Shows the settled settlement amount which was settled on the current business day/during the reporting period.   |
| Debit Credit Indicator                                | Shows if an operation is a credit or a debit from the possible values:<br><input type="checkbox"/> CRDT (for credit)<br><input type="checkbox"/> DBIT (for debit)                    |
| Currency  | Shows the currency code.   |
| Place of Trade Market Identifier Code                 | Shows the identification of a financial market, as stipulated in the norm ISO 10383:2012 "Codes for exchanges and market identifications".   |
| Place of Trade Description                            | Shows the description of the market when no Market Identifier Code is available.   |
| Place of Trade Market Type Code                       | Shows the market type expressed as an ISO 20022 code.  |
| Place of Trade Market Type Proprietary Identification | Shows the proprietary information, often a code, issued by the data source scheme issuer.  |



| General Statement Information                      |  |
|--|--|
| Place of Trade Market Type Proprietary Issuer      | Shows the entity that assigns the identification.  |
| Place of Trade Market Type Proprietary Scheme Name | Shows a short textual description of the scheme.   |
| Place of Clearing                                  | Shows the BIC code of the Clearing House involved in the settlement (if any).  |
| Beneficial Ownership                               | Shows if there is a change of beneficial ownership<br><input type="checkbox"/> Yes<br><input type="checkbox"/> No  |
| Transaction Activity Code                          | Specifies the type of activity to which this instruction relates:<br><input type="checkbox"/> BOLE: Borrowing and Lending Activity;<br><input type="checkbox"/> CLAI: Market Claim;<br><input type="checkbox"/> COLL: Collateral Activity;<br><input type="checkbox"/> CORP: Corporate Action Activity;<br><input type="checkbox"/> SETT: Settlement and Clearing Activity |
| Settlement Parties                                 |  |
| Delivering Parties                                 |  |
| <b>Delivering Depository</b>                       |  |
| Party BIC  | Shows the BIC of the CSD delivering the securities.  |
| <b>Delivering CSD Participant</b>                  |  |
| Party BIC  | Shows the BIC of the delivering CSD participant.   |
| Securities Account Number                          | Shows the securities account number of the delivering CSD participant.<br>This field is optional.  |
| Processing Identification                          | Shows the reference of the instruction assigned by the delivering CSD participant.<br>This field is optional.  |
| <b>Client of the Delivering CSD Participant</b>    |  |
| Party BIC  | Shows the client of the delivering CSD participant BIC.<br>This field is optional.   |

| General Statement Information |   |
|-------------------------------|---|
| Identification                | Shows the unique and unambiguous identifier, as assigned to a financial institution using a proprietary identification scheme.<br>This field is optional. |
| Issuer                        | Shows the name of the issuer of the proprietary identifier.<br>This field is optional.  |
| Scheme Name                   | Shows the name of the scheme.<br>This field is optional.  |
| Name                          | Shows the name and address of the client.<br>This field is optional.  |
| <b>Delivering Party 3</b>     |   |
| Party BIC                     | Shows the BIC of the delivering party 3.<br>This field is conditional.  |
| Identification                | Shows the identification of the processing provided by the party.<br>This field is conditional.   |
| Issuer                        | Shows the entity that assigns the identification.<br>This field is conditional.   |
| Scheme Name                   | Shows the name of the scheme.<br>This field is conditional.   |
| Name                          | Shows the name of the delivering party 3.<br>This field is conditional.   |
| <b>Delivering Party 4</b>     |   |
| Party BIC                     | Shows the BIC of the delivering party 4.<br>This field is conditional.  |
| Identification                | Shows the identification of the processing provided by the party.<br>This field is conditional.   |
| Issuer                        | Shows the entity that assigns the identification.<br>This field is conditional.   |
| Scheme Name                   | Shows the name of the scheme.<br>This field is conditional.   |
| Name                          | Shows the name of the delivering party 4.   |

| General Statement Information           |   |
|---|---|
|   | This field is conditional.  |
| Delivering Party 5                      |   |
| Party BIC                               | Shows the BIC of the delivering party 5.<br>This field is conditional.  |
| Identification                          | Shows the identification of the processing provided by the party.<br>This field is conditional.   |
| Issuer                                  | Shows the entity that assigns the identification.<br>This field is conditional.   |
| Scheme Name                             | Shows the name of the scheme.<br>This field is conditional.   |
| Name                                    | Shows the name of the delivering party 5.<br>This field is conditional.   |
| Settlement Parties                      |   |
| Receiving Parties                       |   |
| Receiving Depository                    |   |
| Party BIC                               | Shows the BIC of the CSD receiving the securities.  |
| Receiving CSD Participant               |   |
| Party BIC                               | Shows the BIC of the receiving CSD participant.   |
| Securities Account Number               | Shows the securities account number of the receiving CSD participant.<br>This field is optional.  |
| Client of the Receiving CSD Participant |   |
| Party BIC                               | Shows the client of the receiving CSD participant BIC.<br>This field is optional.   |
| Identification                          | Shows the unique and unambiguous identifier, as assigned to a financial institution using a proprietary identification scheme.<br>This field is optional. |
| Issuer                                  | Shows the name of the issuer of the proprietary identifier.<br>This field is optional.  |
| Scheme Name                             | Shows the name of the scheme.<br>This field is optional.  |

| General Statement Information |   |
|-------------------------------|---|
| Name                          | Shows the name and address of the client.<br>This field is optional.                            |
| <b>Receiving Party 3</b>      |   |
| Party BIC                     | Shows the BIC of the receiving party 3.<br>This field is conditional.                           |
| Identification                | Shows the identification of the processing provided by the party.<br>This field is conditional. |
| Issuer                        | Shows the entity that assigns the identification.<br>This field is conditional.                 |
| Scheme Name                   | Shows the name of the scheme.<br>This field is conditional.                                     |
| Name                          | Shows the name of the receiving party 3.<br>This field is conditional.                          |
| <b>Receiving Party 4</b>      |   |
| Party BIC                     | Shows the BIC of the receiving party 4.<br>This field is conditional.                           |
| Identification                | Shows the identification of the processing provided by the party.<br>This field is conditional. |
| Issuer                        | Shows the entity that assigns the identification.<br>This field is conditional.                 |
| Scheme Name                   | Shows the name of the scheme.<br>This field is conditional.                                     |
| Name                          | Shows the name of the receiving party 4.<br>This field is conditional.                          |
| <b>Receiving Party 5</b>      |   |
| Party BIC                     | Shows the BIC of the receiving party 5.<br>This field is conditional.                           |
| Identification                | Shows the identification of the processing provided by the party.<br>This field is conditional. |
| Issuer                        | Shows the entity that assigns the identification.   |

| General Statement Information              |  |
|--|--|
|  | This field is conditional.   |
| Scheme Name                                | Shows the name of the scheme.<br>This field is conditional.  |
| Name                                       | Shows the name of the receiving party 5.<br>This field is conditional.   |
| Statement - Further Information            |  |
| ISO Transaction Code                       | Shows the code of the transaction code as defined in ISO 20022.  |
| Settlement Transaction Condition Indicator | Shows the Settlement Transaction Condition Indicator.<br>This field can show multiple Settlement Transaction Condition Indicators.   |
| Partial Settlement Indicator               | Shows if the settlement instruction is allowed to be subject to partial settlement from the possible values: <ul style="list-style-type: none"> <li><input type="checkbox"/> NPAR (for no partial settlement allowed)</li> <li><input type="checkbox"/> PART (for partial settlement allowed without restrictions)</li> <li><input type="checkbox"/> PARC (for partial settlement allowed but the settlement amount must not be below the threshold)</li> <li><input type="checkbox"/> PARQ (for partial settlement allowed but the quantity must not be below the threshold)</li> </ul> |
| Corporate Action Event Identification      | Shows the identification of the instruction assigned by the account servicer to identify a corporate action event.   |

### 2.4.1.21 Available Report – Daily Penalty List – Details Screen

#### Context of Usage

This screen displays detailed information on the Daily Penalty List report. The report displayed in this screen has to be already created in accordance with its report configuration. Hence, no new report will be created by entering this screen.

For large reports the user has the option to view them in portions of up to 200 penalties. Only the current portion of the report will be available for downloading or for printing.

This screen is only available for CSD authorised users and T2S Operator user.

**Screen Access**  Services >> Additional Services >> Reports >> *Available reports – search/list* screen >> Click on the *search* and/or *details* button >> *Available report – details* screen >> Click on the *details* button

**Privileges** To use this screen, you need the following privilege:  
 Report details query

**References** **User Instructions Part**

This screen is part of the following business scenario:

- View available reports

**Business Functionality Document**

This screen corresponds to the following business function:

- Display generated report details (T2S.GUI.INSE.RPT.0090)

**Screenshot**

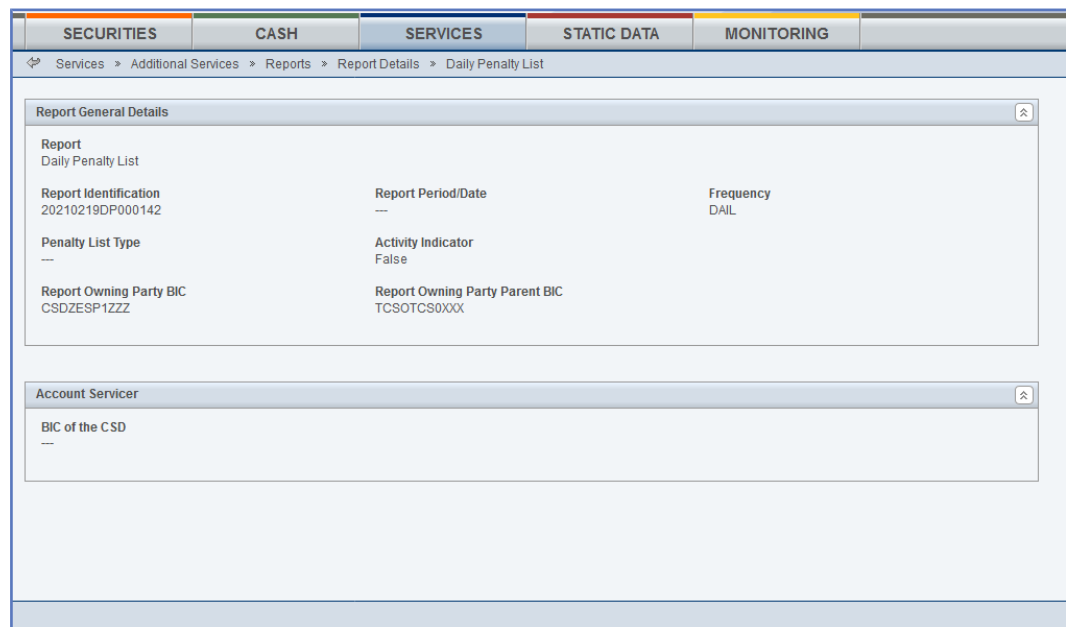

Illustration 113: Available report – daily penalty list – details screen

**Field Description**

| Report General Details |  |
|------------------------|--|
| Report                 | Shows the name of the report.  |
| Report Identification  | Shows the penalty number of the report composed of the business date and report types, sent in pull and push mode by T2S, and the sequential number, which is unique in T2S. The number increases for each report. |
| Report Period/Date     | Shows the date reported by the report.   |

| Report General Details         |   |
|--------------------------------|---|
| Frequency                      | Indicates the frequency of the generation of the report.<br>The unique possible value is:<br><input type="checkbox"/> DAIL  |
| Penalty List Type              | Shows the new or updated/removed detected penalties.<br>The unique possible value is:<br><input type="checkbox"/> FWIS this code is used to report a Daily Penalty List created for the first time. |
| Activity Indicator             | Shows if the message contains records or not.<br>The possible values are:<br><input type="checkbox"/> True<br><input type="checkbox"/> False  |
| Report Owning Party BIC        | Shows the Party BIC whose data is reported on.  |
| Report Owning Party Parent BIC | Shows the Party Parent BIC whose data is reported on.   |
| Account Servicer               |   |
| BIC of the CSD                 | Shows the CSD of the participant whose new penalties (i.e. the one detected on the previous business day) are reported in this message.   |
| Currency, Date and Party       |   |
| Currency                       | Shows the currency of the penalties reported.   |
| Date                           | Shows the detection date of the penalties.  |
| Party BIC                      | Shows the BIC of the Party that manages the account on behalf of the party account owner.   |
| Party Type                     | Shows the Party Type of the Party according to Reference Data.<br>The possible values are:  |

| Report General Details             |   |
|------------------------------------|---|
|                                    | <ul style="list-style-type: none"> <li><input type="checkbox"/> NCSD is provided when the CSD itself is the failing or non failing party of the penalty/claim. This is used to differentiate between the CSD and the CSD as participant of itself. It is needed because the AccountServicer/Depository of the party provided in the message is the BIC of the CSD of the party, not the parent BIC of the party. Consequently, without this additional identification, it wouldn't be possible to distinguish between a CSD and the CSD as participant of itself.</li> <li><input type="checkbox"/> <del>CCPA is provided when the failing or non failing party of the penalty/claim is a CCP; i.e.: in T2S this is done by checking if the party has a BIC in the Cash Penalties CCP List (list of BICs).</del></li> <li><input type="checkbox"/> CSDP is provided when the failing or non failing party of the penalty/claim is <b>neither not</b> a CSD <b>nor a CCP</b> and its party type is CSD Participant.</li> <li><input type="checkbox"/> EXTE is provided when the failing or non failing party of the penalty/claim is <b>neither not</b> a CSD <b>nor a CCP</b> and its party type is an external CSD in T2S.<b>{CR-806}</b></li> </ul> |
| Counterparty                       |   |
| BIC of the CSD of the counterparty | Shows the CSD of the counterparty of the penalties reported in this block of the message  |
| Counterparty BIC                   | Shows the BIC of the Party that manages the account on behalf of the counterparty account owner.  |



| Report General Details |  |
|------------------------|--|
| Counterparty Type      | Shows the BIC of the Party that manages the account on behalf of the counterparty account owner.<br><br>The possible values are:<br><input type="checkbox"/> NCSD<br><input type="checkbox"/> <b>CCPA {CR-806}</b><br><input type="checkbox"/> CSDP<br><input type="checkbox"/> EXTE |
| Aggregated Amount      | Shows the net amount of all the newly detected penalties reported for the given business day in the related currency for the relevant party and counterparty.  |
| Credit/Debit           | Shows whether the Daily Aggregated Net Amount is due or to be received by the participant.<br><br>The possible values are:<br><input type="checkbox"/> DBIT(Debit)<br><input type="checkbox"/> CRDT(Credit)<br><br>If no value is retrieve, it will show “---”                       |
| Penalty                |  |
| Common ID              | Shows the reference assigned by T2S to the penalty that is common for both the failing and the non-failing participant.  |
| Individual ID          | Shows the reference assigned by T2S to the penalty that is the individual identification of the penalty for the relevant account owner.  |
| Type                   | Shows the type of the penalty.<br><br>The possible values are:<br><input type="checkbox"/> SEFP<br><input type="checkbox"/> LMFP   |
| Status                 | Shows the status of the penalty.<br><br>The unique possible value is:  |

| Report General Details |   |
|------------------------|---|
|                        | <input type="checkbox"/> ACTV   |
| Amount of the Penalty  | Shows the amount computed for the penalty and its corresponding currency.   |
| Credit/Debit Indicator | Shows whether the amount of the penalty is due or to be received by the participant.<br><br>The possible values are: <ul style="list-style-type: none"> <li><input type="checkbox"/> DBIT(Debit)</li> <li><input type="checkbox"/> CRDT(Credit)</li> </ul>  |
| Calculation Method     | Shows the calculation method used to calculate the penalty.<br><br>The possible values are: <ul style="list-style-type: none"> <li><input type="checkbox"/> SECU - The Penalty is based on the quantity of securities failed to be delivered and security penalty rate of the relevant Asset type.</li> <li><input type="checkbox"/> MIXE - The Penalty is based on the quantity of securities failed to be delivered and penalty rate is the discount rate of the relevant currency.</li> <li><input type="checkbox"/> CASH - Penalty is based on the amount of cash failed to be delivered and the penalty rate is the discount rate of the relevant currency.</li> <li><input type="checkbox"/> BOTH - Penalty is the sum of "SECU" and "CASH".</li> </ul> |
| Number of Days         | Shows the number of business days the penalty is applicable to.   |
| Calculation Data       |   |
| Date                   | Shows the business day of each sub-amount that forms a penalty.   |
| Missing Reference Data | This information is only provided for penalties where there is missing reference data needed for their calculation.<br><br>The possible values are:   |

| Report General Details        |   |
|-------------------------------|---|
|                               | <ul style="list-style-type: none"> <li><input type="checkbox"/> TRUE – There is missing reference data on the applicable business day.</li> <li><input type="checkbox"/> FALSE – There is no missing reference data on the applicable business day.</li> </ul> <p>If not provided, it means the penalty could be calculated and no reference was missing.</p>   |
| ISIN                          | Shows the ISIN code of the security.  |
| Security Subject to Penalties | <p>Shows whether the security is subject to penalties on this business day or not.</p> <p>The possible values are:</p> <ul style="list-style-type: none"> <li><input type="checkbox"/> TRUE - The security is subject to penalties.</li> <li><input type="checkbox"/> FALSE - The security is not subject to penalties.</li> </ul> <p>When not informed, it will mean "TRUE".</p>   |
| Financial Instrument Type     | <p>Shows the type of the financial instrument.</p> <p>The possible values are:</p> <ul style="list-style-type: none"> <li><input type="checkbox"/> SHRS</li> <li><input type="checkbox"/> SOVR</li> <li><input type="checkbox"/> DEBT</li> <li><input type="checkbox"/> SECU</li> <li><input type="checkbox"/> ETFS</li> <li><input type="checkbox"/> UCIT</li> <li><input type="checkbox"/> MMKT</li> <li><input type="checkbox"/> EMAL</li> <li><input type="checkbox"/> OTHR</li> </ul> <p>If no value is retrieve, it will show "---"</p> |
| Liquidity                     | Binary classification of securities which indicates whether the underlying instrument is liquid or illiquid.  |

| Report General Details |   |
|------------------------|---|
|                        | <p>Only provided if:</p> <ul style="list-style-type: none"> <li><input type="checkbox"/> The Security is Subject to penalties</li> <li><input type="checkbox"/> The Financial Instrument Type of the security (Classification type) is “SHRS”, and</li> <li><input type="checkbox"/> The Calculation method code is “SECU” or “BOTH”.</li> </ul> <p>The possible values are:</p> <ul style="list-style-type: none"> <li><input type="checkbox"/> Empty (“---”), it is not relevant for the calculation of the penalty or for information purposes whether the instrument is liquid or illiquid.</li> <li><input type="checkbox"/> TRUE, the underlying instrument is liquid.</li> <li><input type="checkbox"/> FALSE, the underlying instrument is illiquid.</li> </ul> |
| Exchange Rate          | <p>Shows the value of one currency expressed in relation to another currency (i.e. ExchangeRate expresses the ratio between UnitCurrency and QuotedCurrency).</p> <p>If no value is retrieve, it will show “---”</p>  |
| Unit Currency          | <p>Shows the currency in which the rate of exchange is expressed in a currency exchange. It is always EUR.</p> <p>If no value is retrieve, it will show “---”</p>   |
| Quoted Currency        | <p>Shows the currency into which the base currency is converted, in a currency exchange. Possible values are:</p> <p>For first FX: The quoted currency is either the currency of the price when the security is in Units, or the currency of the security if the security is in FAMT.</p> <p>If no value is retrieve, it will show “---”</p>  |

| Report General Details                |  |
|---------------------------------------|--|
| Exchange Rate                         | Shows the second value of one currency expressed in relation to another currency (i.e. ExchangeRate expresses the ratio between UnitCurrency and QuotedCurrency), if any.  |
| Unit Currency                         | Shows the currency in which the rate of exchange is expressed in a currency exchange. It is always EUR.  |
| Quoted Currency                       | Shows the currency into which the base currency is converted, in a currency exchange.<br><br>For second FX: The quoted currency is the currency of the penalty: For the time being, it is always DKK.  |
| Place of Trade Market Identifier Code | Shows the identifier Code of the market in which a trade transaction has been executed.<br><br>Informed only if Security is subject to penalties, Calculation method code is SECU or BOTH and the two underlying matched settlement instructions have the same MIC in their Place of Trade.<br><br>If MIC differs, the value informed will be "empty".   |
| SME Growth Market                     | Shows whether the instructions were traded in a SME Growth Market or not.<br><br>Only provided if: <ul style="list-style-type: none"><li><input type="checkbox"/> The Security is Subject to penalties</li><li><input type="checkbox"/> The Financial Instrument Type of the security (Classification type) is different from SOVR, and</li><li><input type="checkbox"/> The Calculation method code is "SECU" or "BOTH".</li></ul> The possible values are: |

| Report General Details     |   |
|----------------------------|---|
|                            | <ul style="list-style-type: none"> <li><input type="checkbox"/> Empty (“---”), it is not relevant for the calculation of the penalty or for information purposes whether the instructions were traded on a SME Growth Market or not</li> <li><input type="checkbox"/> TRUE, the instructions were traded on a SME Growth Market.</li> <li><input type="checkbox"/> FALSE, the instructions were not traded on a SME Growth Market.</li> </ul> |
| Security Penalty Rate      | Shows the Securities Penalty Rate applicable for the Asset Type, used when the calculation method code of the penalty is “SECU” or “BOTH”.  |
| Cash Discount Penalty Rate | Shows the discount rate of the relevant currency for the business date.<br><br>It is provided if the Security is subject to penalties and if the Calculation Method code is “CASH”, “MIXE” or “BOTH”.   |
| Sub-amount Securities      | Shows the amount of the penalty for this business day.<br><br>It is only provided if the number of days is higher than one (i.e. when it is a LMFP and the block calculation details could have more than one instance) or if the calculation method is “BOTH” (in this case also Sub-amount cash is provided)  |
| Sub-amount Cash            | Shows the amount of the penalty for this business day.<br><br>It is only provided if the number of business days is higher than one (i.e. when it is a LMFP and the block calculation details could have more than one instance) or if the calculation method is “BOTH” (in this case also Sub-amount securities is provided)   |
| Related Transaction        |   |
| References                 |   |

| Report General Details                |  |
|---------------------------------------|--|
| Account Owner Reference               | Shows the reference of an instruction as assigned by the T2S Delivering/Receiving Party.   |
| Account Servicer Reference            | Shows the reference of an instruction as assigned by the CSD.  |
| Market Infrastructure Reference       | Shows the T2S settlement instruction identification.   |
| Third Party Reference                 | Shows the reference assigned by the Third Party, if any.   |
| Common Reference                      | Shows the reference of the Settlement Instruction this Settlement Instruction is matched with.   |
| Corporate Action Event Identification | Shows the identification assigned by the account servicer to unambiguously identify a corporate action event   |
| T2S Matching Reference                | Shows the reference provided by T2S when the instruction is matched.   |
| Reference Owner BIC                   | Shows the BIC of the instructing party of the settlement instruction.  |
| Other details                         |  |
| Securities Transaction Type           | Shows the securities transaction type expressed as an ISO 20022 code from the possible values: <ul style="list-style-type: none"> <li><input type="checkbox"/> AUTO (for auto-collateralisation)</li> <li><input type="checkbox"/> BSBK (for buy sell back)</li> <li><input type="checkbox"/> BYIY (for buy-in)</li> <li><input type="checkbox"/> CLAI (for market claim)</li> <li><input type="checkbox"/> CNCB (for central bank collateral operation)</li> <li><input type="checkbox"/> COLI (for collateral in)</li> <li><input type="checkbox"/> COLO (for collateral out)</li> <li><input type="checkbox"/> CONV (for depository receipt conversion)</li> <li><input type="checkbox"/> CORP (for corporate action)</li> <li><input type="checkbox"/> ETFT (for exchange traded funds)</li> </ul> |

**Report General Details**

- FCTA (for factor update)
- INSP (for move of stock)
- ISSU (for depository receipt issue)
- MKDW (for mark down)
- MKUP (for mark up)
- NETT (for netting)
- NSYN (for non syndicated)
- OWNE (for external account transfer)
- OWNI (for internal account transfer)
- PAIR (for pair off)
- PLAC (for placement)
- PORT (for portfolio move)
- REAL (for realignment)
- REBL (Rebalancing)
- REDI (for withdrawal)
- REDM (for redemption)
- RELE (for depository receipt release cancellation)
- REPU (for repo)
- RODE (for return delivery without matching)
- RVPO (for reverse repo)
- SBBK (for sell buy back)
- SBRE (for borrowing reallocation)
- SECB (for securities borrowing)
- SECL (for securities lending)
- SLRE (for lending reallocation)
- SUBS (for subscription)
- SWIF (Switch From)
- SWIT (Switch To)
- SYND (for syndicate underwriters)
- TBAC (for TBA closing)



| Report General Details    |  |
|---------------------------|--|
|                           | <input type="checkbox"/> TRAD (for trade)<br><input type="checkbox"/> TRPO (for triparty repo)<br><input type="checkbox"/> TRVO (for triparty reverse repo)<br><input type="checkbox"/> TURN (for turnaround)              |
| Intended Settlement Date  | Shows the date at which the instruction becomes eligible to be submitted to settlement.  |
| Securities Account Number | Shows the identification of the Securities Account of the Settlement Instruction.  |
| Account Owner BIC         | Shows the actual value for the party code owner of the Securities Account.   |
| Securities Movement Type  | Shows whether the movement on a securities account results from a deliver or a receive instruction.<br><br>The possible values are:<br><input type="checkbox"/> DELI – Delivery<br><input type="checkbox"/> RECE – Receipt |
| Payment type code         | Shows how the transaction is to be settled.<br><br>The possible values are:<br><input type="checkbox"/> APMT – Against payment settlement<br><input type="checkbox"/> FREE – Separate settlement                           |
| Unit Quantity             | Shows the unit quantity of securities failed to be delivered.  |
| FAMT Quantity             | Shows the FAMT quantity of securities failed to be delivered.  |
| DCA Owner BIC             | Shows the BIC of the T2S party owning the Dedicated Cash Account.<br><br>Only in case of settlement instructions against payment.  |
| Amount                    | Cash amount failed to be delivered, and its corresponding currency.  |

| Report General Details   |  |
|--------------------------|--|
|                          | <p>In case the instruction was partially settled at the moment of the end of cut-off processing used for the calculation of the SEFP, it is the remaining amount at that point in time.</p> <p>For LMFPs it is the matched amount.</p>           |
| Credit/Debit             | <p>It must be present when the Original Settlement Amount has a value.</p> <p>The possible values are:</p> <ul style="list-style-type: none"> <li><input type="checkbox"/> DBIT(Debit)</li> <li><input type="checkbox"/> CRDT(Credit)</li> </ul> |
| Acknowledged Status TS   | Shows the Calendar Date when the acceptance (SF1) of the settlement instruction has occurred   |
| Matched Status Timestamp | Shows the Calendar Date when the matching (SF2) of the settlement instruction has occurred   |
| Failed Reason            | <p>T2S sends this status when the Settlement Instruction has not been completely settled and the settlement is not possible at the Intended Settlement Date.</p> <p>It is only provided in case of 'SEFP'</p>                                    |
| Additional Reason        | <p>Shows the combination of the associated business rule and reason code reference,</p> <p>It is only provided in case of 'SEFP'</p>   |
| BD Event Identification  | <p>Shows the code identifying the event (i.e. Cut-off- Code identifying the event)</p> <p>It is only provided in case of 'SEFP'</p>  |
| Scheme Name              | <p>Shows the name of the scheme.</p> <p>Fixed content to 'EVTP'</p> <p>It is only provided in case of 'SEFP'</p>   |
| Issuer                   | <p>Shows the entity assigning the identification.</p> <p>Fixed content to 'T2S'</p>  |

| Report General Details |   |
|------------------------|---|
|                        | It is only provided in case of 'SEFP'   |
| Scheduled Time         | Shows the effective time for the schedule of the cut-off<br>It is only provided in case of 'SEFP' |
| Start Time             | Shows the effective time for the trigger of the cut-off<br>It is only provided in case of 'SEFP'  |
| End Time               | Shows the effective time for the closure of the Cut-off<br>It is only provided in case of 'SEFP'  |

## 2.4.1.22 Available Report – List of Modified Penalties - Details Screen

### Context of Usage

This screen displays detailed information on the List of Modified Penalties report. The report displayed in this screen has to be already created in accordance with its report configuration. Hence, no new report will be created by entering this screen.

For large reports the user has the option to view them in portions of up to 200 penalties. Only the current portion of the report will be available for downloading or for printing.

This screen is only available for CSD authorised users and T2S Operator user.

### Screen Access

Services >> Additional Services >> Reports >> *Available reports – search/list* screen >> Click on the *search* and/or *details* button >> *Available report – details* screen >> Click on the *details* button

### Privileges

To use this screen, you need the following privilege:

Report details query

### References

#### User Instructions Part

This screen is part of the following business scenario:

View available reports

#### Business Functionality Document

This screen corresponds to the following business function:

Display generated report details (T2S.GUI.INSE.RPT.0090)

Screenshot

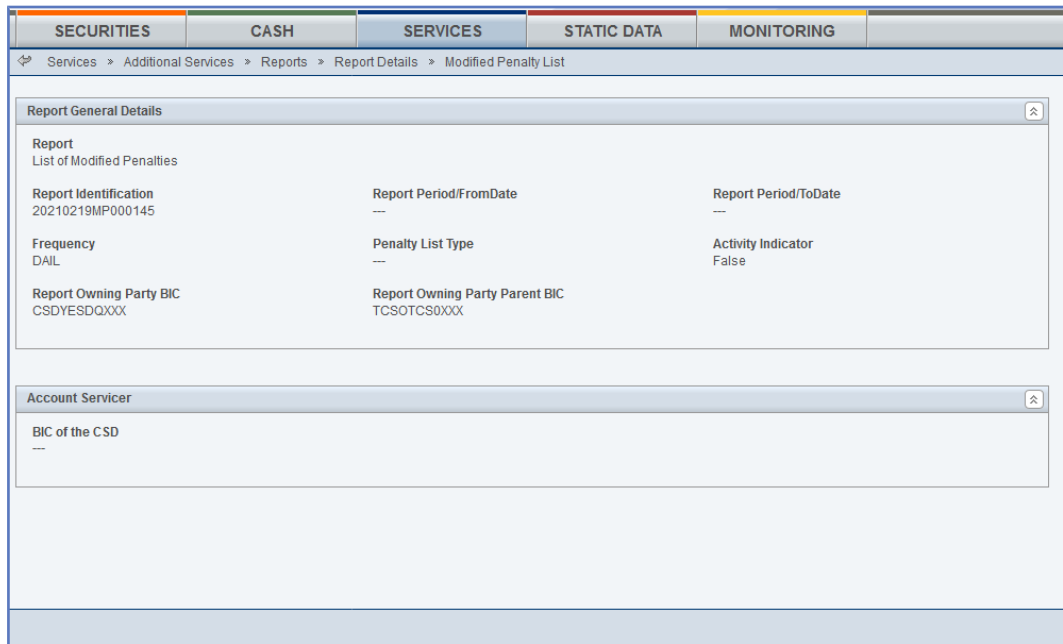

Illustration 114: Available report – list of modified penalties – details screen

Field

Description

| Report General Details  |  |
|-------------------------|--|
| Report                  | Shows the name of the report.  |
| Report Identification   | Shows the penalty number of the report composed of the business date and report types, sent in pull and push mode by T2S, and the sequential number, which is unique in T2S. The number increases for each report. |
| Reporte Period/FromData | Shows the start date of the range.   |
| Report Period/ToDate    | Shows the end date of the range.   |
| Frequency               | Indicates the frequency of the generation of the report. The unique possible value is:<br><input type="checkbox"/> DAIL  |
| Penalty List Type       | Shows the new or updated/removed detected penalties. The unique possible value is:<br><input type="checkbox"/> FWAM this code is used to report a penalty list that has been amended.                              |
| Activity Indicator      | Shows if the message contains records or not.  |

| Report General Details         |  |
|--------------------------------|--|
|                                | <p>The possible values are:</p> <ul style="list-style-type: none"> <li><input type="checkbox"/> True</li> <li><input type="checkbox"/> False</li> </ul>  |
| Report Owning Party BIC        | Shows the Party BIC whose data is reported on.   |
| Report Owning Party Parent BIC | Shows the Party Parent BIC whose data is reported on.  |
| Account Servicer               |  |
| BIC of the CSD                 | Shows the CSD of the participant whose modified penalties are reported in this message.  |
| Currency, Date and Party       |  |
| Currency                       | Shows the currency of the modified penalties reported.   |
| Date                           | Shows the detection date of the penalties.   |
| Party BIC                      | Shows the BIC of the Party that manages the account on behalf of the party account owner.  |
| Party Type                     | <p>Shows the Party Type of the Party according to Reference Data.</p> <p>The possible values are:</p> <ul style="list-style-type: none"> <li><input type="checkbox"/> NCSD is provided when the CSD itself is the failing or the non failing party of the penalty/claim. This is used to differentiate between the CSD and the CSD as participant of itself. It is needed because the AccountServicer/Depository of the party provided in the message is the BIC of the CSD of the party, not the parent BIC of the party. Consequently, without this additional identification, it wouldn't be possible to distinguish between a CSD and the CSD as participant of itself.</li> </ul> |

| Report General Details             |   |
|------------------------------------|---|
|                                    | <ul style="list-style-type: none"> <li><input type="checkbox"/> <del>CCPA is provided when the failing or non failing party of the penalty/claim is a CCP; i.e. In T2S this is done by checking if the party has a BIC in the Cash Penalties CCP List (list of BICs).</del></li> <li><input type="checkbox"/> CSDP is provided when the failing or non failing party of the penalty/claim is <b>neither not</b> a CSD <b>nor a CCP</b> and its party type is CSD Participant.</li> <li><input type="checkbox"/> EXTE is provided when the failing or non failing party of the penalty/claim is <b>neither not</b> a CSD <b>nor a CCP</b> and its party type is an external CSD in T2S. <b>{CR-806}</b></li> </ul> |
| Counterparty                       |   |
| BIC of the CSD of the counterparty | Shows the CSD of the counterparty of the penalties reported in this block of the message.   |
| Counterparty BIC                   | Shows the BIC of the Party that manages the account on behalf of the counterparty account owner.  |
| Counterparty Type                  | Shows the BIC of the Party that manages the account on behalf of the counterparty account owner.<br>The possible values are: <ul style="list-style-type: none"> <li><input type="checkbox"/> NCSD</li> <li><input type="checkbox"/> <b>CCPA</b> <b>{CR-806}</b></li> <li><input type="checkbox"/> CSDP</li> <li><input type="checkbox"/> EXTE</li> </ul>  |
| Aggregated Amount                  | Shows the net amount of all the penalties reported for the given business day in the related currency for the relevant party and counterparty.  |

| Report General Details |   |
|------------------------|---|
| Credit/Debit           | Shows whether the Daily Modified Aggregated Net Amount is due or to be received by the participant.<br><br>The possible values are:<br><input type="checkbox"/> DBIT(Debit)<br><input type="checkbox"/> CRDT(Credit)<br><br>If no value is retrieve, it will show “---” |
| Penalty                |   |
| Common ID              | Shows the reference assigned by T2S to the penalty and that is common for both the failing and the non-failing participant.   |
| Individual ID          | Shows the reference assigned by T2S to the penalty and that is the individual identification of the penalty for the relevant account owner.   |
| Reallocation ID        | Shows the Common Reference of either the penalty from which the reported penalty was re-allocated or the penalty to which the reported penalty has been re-allocated.   |
| Type                   | Shows the type of the penalty.<br><br>The possible values are:<br><input type="checkbox"/> SEFP<br><input type="checkbox"/> LMFP  |
| Status                 | Shows the status of the penalty.<br><br>The possible values are:<br><input type="checkbox"/> ACTV<br><input type="checkbox"/> REMO<br><br>Note: If the status of the penalty is REMO, the attributes of “Calculation Details” are not visible.                          |
| Reason                 | Shows the reason of the status.<br><br>The possible values are:   |

| Report General Details   |  |
|--------------------------|--|
|                          | <ul style="list-style-type: none"> <li><input type="checkbox"/> UPDT - Active penalty that has been updated.</li> <li><input type="checkbox"/> NEWP (New penalty resulting from the insertion of a Security Subject to Penalties with Valid From in the past, or from a contingency scenario)</li> <li><input type="checkbox"/> RALO - Active or Removed penalty has been re-allocated.</li> <li><input type="checkbox"/> SWIC - Active penalty has been switched (the failing and the non-failing participant have been swapped by the CSD).</li> <li><input type="checkbox"/> INSO - Penalty was removed because insolvency proceedings are opened against the failing participant.</li> <li><input type="checkbox"/> SESU - Penalty was removed because of ISIN suspension from settlement due to a reconciliation issue under.</li> <li><input type="checkbox"/> SUSP - Penalty was removed because of ISIN suspension from trading</li> <li><input type="checkbox"/> SEMP - Penalty removed because of settlement on multiple platforms.</li> <li><input type="checkbox"/> TECH - Penalty was removed because there were technical impossibilities at the CSD level that prevent settlement.</li> <li><input type="checkbox"/> OTHR - Removed Penalty due to a non-standard reason by the CSD.</li> </ul> |
| Additional Status Reason | Shows the additional description of the reason why the penalty has been Removed with Reason OTHR or Switched.  |
| Amount of the Penalty    | Shows the amount of the modified penalty and its corresponding currency.   |



| Report General Details |   |
|------------------------|---|
| Credit/Debit Indicator | Shows whether the penalty is due or to be received by the participant.<br>The possible values are:<br><input type="checkbox"/> DBIT<br><input type="checkbox"/> CRDT  |
| Calculation Method     | Shows the calculation method used to calculate the penalty.<br>The possible values are:<br><input type="checkbox"/> SECU - The Penalty is based on the quantity of securities failed to be delivered and security penalty rate of the relevant Asset type.<br><input type="checkbox"/> MIXE - The Penalty is based on the quantity of securities failed to be delivered and penalty rate is the discount rate of the relevant currency.<br><input type="checkbox"/> CASH - Penalty is based on the amount of cash failed to be delivered and the penalty rate is the discount rate of the relevant currency<br><input type="checkbox"/> BOTH - Penalty is the sum of "SECU" and "CASH". |
| Number of Days         | Shows the number of business days the penalty is applicable to.   |
| Calculation Data       |   |
| Date                   | Shows the business day of each sub-amount that forms a penalty.   |
| Missing Reference Data | This information is only provided for penalties where there is missing reference data needed for the penalty calculation.<br>The possible values are:<br><input type="checkbox"/> TRUE – There is missing reference data on the applicable business day.  |

| Report General Details        |   |
|-------------------------------|---|
|                               | <p><input type="checkbox"/> FALSE – There is no missing reference data on the applicable business day.</p> <p>If not provided, it means the penalty could be calculated and no reference was missing.</p>   |
| ISIN                          | Shows the ISIN code of the security.  |
| Security Subject to Penalties | <p>Shows whether the security is subject to penalties on this business day or not.</p> <p>The possible values are:</p> <ul style="list-style-type: none"> <li><input type="checkbox"/> TRUE - The security is subject to penalties.</li> <li><input type="checkbox"/> FALSE - The security is not subject to penalties.</li> </ul> <p>When not informed, it will mean "TRUE".</p>   |
| Financial Instrument Type     | <p>Shows the type of the financial instrument.</p> <p>The possible values are:</p> <ul style="list-style-type: none"> <li><input type="checkbox"/> SHRS</li> <li><input type="checkbox"/> SOVR</li> <li><input type="checkbox"/> DEBT</li> <li><input type="checkbox"/> SECU</li> <li><input type="checkbox"/> ETFS</li> <li><input type="checkbox"/> UCIT</li> <li><input type="checkbox"/> MMKT</li> <li><input type="checkbox"/> EMAL</li> <li><input type="checkbox"/> OTHR</li> </ul> <p>If no value is retrieve, it will show "---"</p> |
| Liquidity                     | <p>Binary classification of securities which indicates whether the underlying instrument is liquid or illiquid.</p> <p>Only provided if:</p> <ul style="list-style-type: none"> <li><input type="checkbox"/> The Security is Subject to penalties</li> </ul>  |

| Report General Details |   |
|------------------------|---|
|                        | <ul style="list-style-type: none"> <li><input type="checkbox"/> The Financial Instrument Type of the security (Classification type) is “SHRS”, and</li> <li><input type="checkbox"/> The Calculation method code is “SECU” or “BOTH”.</li> </ul> <p>The possible values are:</p> <ul style="list-style-type: none"> <li><input type="checkbox"/> Empty (“---”), it is not relevant for the calculation of the penalty or for information purposes whether the instrument is liquid or illiquid.</li> <li><input type="checkbox"/> TRUE, the underlying instrument is liquid.</li> <li><input type="checkbox"/> FALSE, the underlying instrument is illiquid.</li> </ul> |
| Exchange Rate          | <p>Shows the value of one currency expressed in relation to another currency (i.e. ExchangeRate expresses the ratio between UnitCurrency and QuotedCurrency).</p> <p>If no value is retrieve, it will show “---”</p>  |
| Unit Currency          | <p>Shows the currency in which the rate of exchange is expressed in a currency exchange. It is always EUR.</p> <p>If no value is retrieve, it will show “---”</p>   |
| Quoted Currency        | <p>Shows the currency into which the base currency is converted, in a currency exchange. The possible values are:</p> <p>For first FX: The quoted currency is either the currency of the price when the security is in Units, or the currency of the security if the security is in FAMT.</p> <p>If no value is retrieve, it will show “---”</p>  |

| Report General Details                |  |
|---------------------------------------|--|
| Exchange Rate                         | Shows the second value of one currency expressed in relation to another currency (i.e. ExchangeRate expresses the ratio between UnitCurrency and QuotedCurrency, if any.   |
| Unit Currency                         | Shows the currency in which the rate of exchange is expressed in a currency exchange. It is always EUR.  |
| Quoted Currency                       | Shows the currency into which the base currency is converted, in a currency exchange.<br><br>For second FX: The quoted currency is the currency of the penalty: For the time being, it is always DKK.  |
| Place of Trade Market Identifier Code | Shows the identifier Code of the market in which a trade transaction has been executed.<br><br>Informed only if Security is subject to penalties, Calculation method code is SECU or BOTH and the two underlying matched settlement instructions have the same MIC in their Place of Trade.<br><br>If MIC differs, the value informed will be "empty".   |
| SME Growth Market                     | Shows whether the instructions were traded in a SME Growth Market or not.<br><br>Only provided if: <ul style="list-style-type: none"><li><input type="checkbox"/> The Security is Subject to penalties</li><li><input type="checkbox"/> The Financial Instrument Type of the security (Classification type) is different from SOVR, and</li><li><input type="checkbox"/> The Calculation method code is "SECU" or "BOTH".</li></ul> The possible values are: |

| Report General Details     |   |
|----------------------------|---|
|                            | <ul style="list-style-type: none"> <li><input type="checkbox"/> Empty (“---”), it is not relevant for the calculation of the penalty or for information purposes whether the instructions were traded on a SME Growth Market or not</li> <li><input type="checkbox"/> TRUE, the instructions were traded on a SME Growth Market.</li> <li><input type="checkbox"/> FALSE, the instructions were not traded on a SME Growth Market.</li> </ul> |
| Security Penalty Rate      | Shows the Securities Penalty Rate applicable for the Asset Type, used when the calculation method code of the penalty is “SECU” or “BOTH”.  |
| Cash Discount Penalty Rate | Shows the discount rate of the relevant currency for the business date.<br><br>It is provided if the Security is subject to penalties and if the Calculation Method code is “CASH”, “MIXE” or “BOTH”.   |
| Sub-amount Securities      | Shows the amount of the penalty for this business day.<br><br>It is only provided if the number of days is higher than one (i.e. when it is a LMFP and the block calculation details could have more than one instance) or if the calculation method is “BOTH” (in this case also Sub-amount cash is provided)  |
| Sub-amount Cash            | Shows the amount of the penalty for this business day.<br><br>It is only provided if the number of days is higher than one (i.e. when it is a LMFP and the block calculation details could have more than one instance) or if the calculation method is “BOTH” (in this case also Sub-amount securities is provided)  |
| Related Transactions       |   |
| References                 |   |

| Report General Details  |  |
|---|--|
| Account Owner Reference   | Shows the reference of an instruction as assigned by the T2S Delivering/Receiving Party.   |
| Account Servicer Reference                                      | Shows the reference of an instruction as assigned by the CSD.  |
| Market Infrastructure Reference                                 | Shows the T2S settlement instruction identification.   |
| Third Party Reference   | Shows the reference assigned by the Third Party, if any.   |
| Common Reference  | Shows the reference which indicates the Settlement Instruction this Settlement Instruction is matched with.  |
| Corporate Action Event Identification                           | Shows the identification assigned by the account servicer to unambiguously identify a corporate action event   |
| T2S Matching Reference  | Shows the reference provided by T2S when the instruction is matched.   |
| Reference Owner BIC   | Shows the BIC for the instructing party of the settlement instruction.   |
| Other details (displayed only for Penalties with Reason "NEWP") |  |
| Securities Transaction Type                                     | Shows the securities transaction type expressed as an ISO 20022 code from the possible values: <ul style="list-style-type: none"> <li><input type="checkbox"/> AUTO (for auto-collateralisation)</li> <li><input type="checkbox"/> BSBK (for buy sell back)</li> <li><input type="checkbox"/> BYIY (for buy-in)</li> <li><input type="checkbox"/> CLAI (for market claim)</li> <li><input type="checkbox"/> CNCB (for central bank collateral operation)</li> <li><input type="checkbox"/> COLI (for collateral in)</li> <li><input type="checkbox"/> COLO (for collateral out)</li> <li><input type="checkbox"/> CONV (for depository receipt conversion)</li> <li><input type="checkbox"/> CORP (for corporate action)</li> <li><input type="checkbox"/> ETFT (for exchange traded funds)</li> </ul> |

**Report General Details**

- FCTA (for factor update)
- INSP (for move of stock)
- ISSU (for depository receipt issue)
- MKDW (for mark down)
- MKUP (for mark up)
- NETT (for netting)
- NSYN (for non syndicated)
- OWNE (for external account transfer)
- OWNI (for internal account transfer)
- PAIR (for pair off)
- PLAC (for placement)
- PORT (for portfolio move)
- REAL (for realignment)
- REBL (Rebalancing)
- REDI (for withdrawal)
- REDM (for redemption)
- RELE (for depository receipt release cancellation)
- REPU (for repo)
- RODE (for return delivery without matching)
- RVPO (for reverse repo)
- SBBK (for sell buy back)
- SBRE (for borrowing reallocation)
- SECB (for securities borrowing)
- SECL (for securities lending)
- SLRE (for lending reallocation)
- SUBS (for subscription)
- SWIF (Switch From)
- SWIT (Switch To)
- SYND (for syndicate underwriters)
- TBAC (for TBA closing)

| Report General Details        |  |
|-------------------------------|--|
|                               | <input type="checkbox"/> TRAD (for trade)<br><input type="checkbox"/> TRPO (for triparty repo)<br><input type="checkbox"/> TRVO (for triparty reverse repo)<br><input type="checkbox"/> TURN (for turnaround)                  |
| Intended Settlement Date      | Shows the date at which the instruction becomes eligible to be submitted to settlement.  |
| Securities Account Number     | Shows the identification of the Securities Account of the Settlement Instruction.  |
| Account Owner BIC             | Shows the actual value for the party code owner of the Securities Account.   |
| Securities Movement Type      | <p>Shows whether the movement on a securities account results from a deliver or a receive instruction.</p> <p>The possible values are:</p> <input type="checkbox"/> DELI – Delivery<br><input type="checkbox"/> RECE – Receipt |
| Payment type code             | <p>Shows how the transaction is to be settled.</p> <p>The possible values are:</p> <input type="checkbox"/> APMT – Against payment settlement<br><input type="checkbox"/> FREE – Separate settlement                           |
| Unit Quantity                 | Shows the unit quantity of securities failed to be delivered.  |
| FAMT Quantity                 | Shows the FAMT quantity of securities failed to be delivered.  |
| Dedicated Cash Account Number | Shows the Dedicated Cash Account as per SF1 (if APTM)  |
| DCA Owner BIC                 | <p>Shows the BIC of the T2S party owning the Dedicated Cash Account.</p> <p>Only in case of settlement instructions against payment.</p>   |



| Report General Details   |   |
|--------------------------|---|
| Amount                   | <p>Cash amount failed to be delivered, and its corresponding currency.</p> <p>In case the instruction was partially settled at the moment of the end of cut-off processing used for the calculation of the SEFP, it is the remaining amount at that point in time.</p> <p>For LMFPs it is the matched amount.</p> |
| Credit/Debit             | <p>It must be present when the Original Settlement Amount has a value.</p> <p>The possible values are:</p> <ul style="list-style-type: none"> <li><input type="checkbox"/> DBIT (Debit)</li> <li><input type="checkbox"/> CRDT (Credit)</li> </ul>  |
| Acknowledged Status TS   | Shows the Calendar Date when the acceptance (SF1) of the settlement instruction has occurred  |
| Matched Status Timestamp | Shows the Calendar Date when the matching (SF2) of the settlement instruction has occurred  |
| Failed Reason            | <p>T2S sends this status when the Settlement Instruction has not been completely settled and the settlement is not possible at the Intended Settlement Date.</p> <p>It is only provided in case of 'SEFP'</p>   |
| Additional Reason        | <p>Shows the combination of the associated business rule and reason code reference,</p> <p>It is only provided in case of 'SEFP'</p>  |
| BD Event Identification  | <p>Shows the code identifying the event (i.e. Cut-off- Code identifying the event)</p> <p>It is only provided in case of 'SEFP'</p>   |
| Scheme Name              | <p>Shows the name of the scheme.</p> <p>Fixed content to 'EVTP'</p> <p>It is only provided in case of 'SEFP'</p>  |

| Report General Details |   |
|------------------------|---|
| Issuer                 | Shows the entity assigning the identification.<br>Fixed content to 'T2S'<br>It is only provided in case of 'SEFP' |
| Scheduled Time         | Shows the effective time for the schedule of the cut-off<br>It is only provided in case of 'SEFP'                 |
| Start Time             | Shows the effective time for the trigger of the cut-off<br>It is only provided in case of 'SEFP'                  |
| End Time               | Shows the effective time for the closure of the Cut-off<br>It is only provided in case of 'SEFP'                  |

### 2.4.1.23 Available Report – Monthly Aggregated Amounts – Details Screen

#### Context of Usage

This screen displays detailed information on the Monthly Aggregated Amounts report. The report displayed in this screen has to be already created in accordance with its report configuration. Hence, no new report will be created by entering this screen.

For large reports the user has the option to view them in portions of up to 500 penalties. Only the current portion of the report will be available for a downloading or for printing.

This screen is only available for CSD authorised users and T2S Operator user.

#### Screen Access

Services >> Additional Services >> Reports >> *Available reports – search/list* screen >> Click on the *search* and/or *details* button >> *Available report – details* screen >> Click on the *details* button

#### Privileges

To use this screen, you need the following privilege:

Report details query

#### References

##### User Instructions Part

This screen is part of the following business scenario:

View available reports

### Business Functionality Document

This screen corresponds to the following business function:

- Display generated report details (T2S.GUI.INSE.RPT.0090)

#### Screenshot

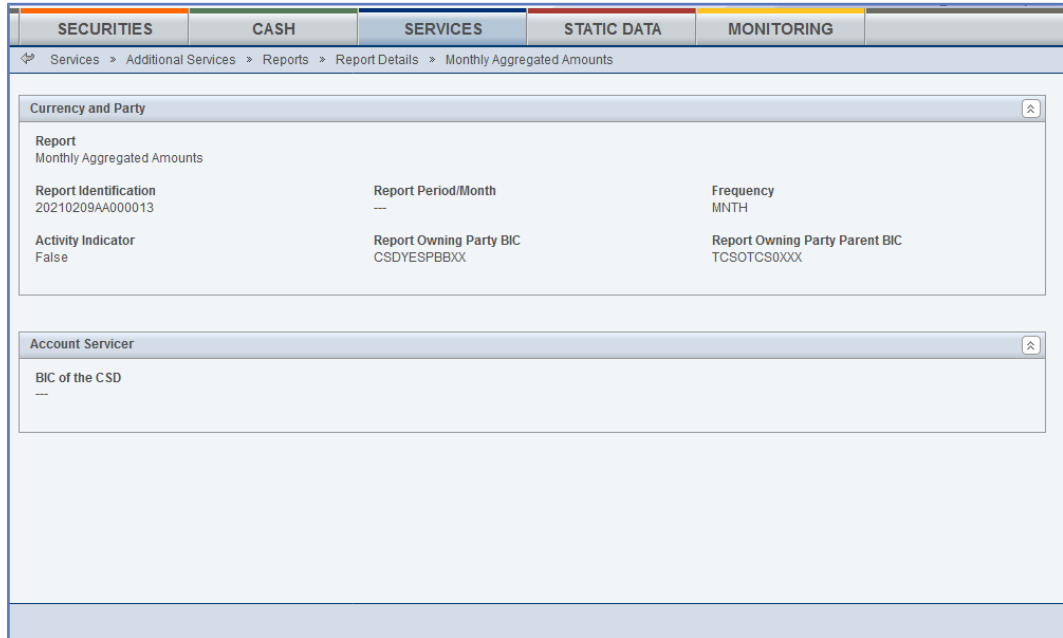

Illustration 115: Available report – monthly aggregated amounts – details screen

#### Field

#### Description

| Report General Details |  |
|------------------------|--|
| Report                 | Shows the name of the report.  |
| Report Identification  | Shows the penalty number of the report composed of the business date and report types, sent in pull and push mode by T2S, and the sequential number, which is unique in T2S. The number increases for each report. |
| Report Period/Month    | Shows the month reported (whose penalties  |
| Frequency              | Indicates the frequency of the generation of the report. The unique possible value is: <input type="checkbox"/> MNTH   |
| Activity Indicator     | Shows if the message contains records or not. The possible values are: <input type="checkbox"/> True   |

| Report General Details        |  |
|-------------------------------|--|
|                               | <input type="checkbox"/> False   |
| Report Owing Party BIC        | Shows the Party BIC whose data is reported on.   |
| Report Owing Party Parent BIC | Shows the Party Parent BIC whose data is reported on.  |
| Account Servicer              |  |
| BIC of the CSD                | Shows the CSD of the participant whose penalties are reported in this message.   |
| Currency and Party            |  |
| Currency                      | Shows the currency of the penalties reported.  |
| Party BIC                     | Shows the BIC of the Party that manages the account on behalf of the party account owner.  |
| Party Type                    | <p>Shows the Party Type of the Party according to T2S Reference Data.</p> <p>The possible values are:</p> <ul style="list-style-type: none"> <li><input type="checkbox"/> NCSD is provided when the CSD itself is the failing or non failing party of the penalty/claim. This is used to differentiate between the CSD and the CSD as participant of itself. It is needed because the AccountServicer/Depository of the party provided in the message is the BIC of the CSD of the party, not the parent BIC of the party. Consequently, without this additional identification, it won't be possible to distinguish between a CSD and the CSD as participant of itself.</li> <li><input type="checkbox"/> <b>CCPA is provided when the failing or non failing party of the penalty/claim is a CCP; i.e. In T2S this is done by checking if the</b></li> </ul> |

| Report General Details             |  |
|------------------------------------|--|
|                                    | <p><del>party has a BIC in the Cash Penalties CCP List (list of BICs).</del><br/><b>{CR-806}</b></p> <ul style="list-style-type: none"> <li><input type="checkbox"/> CSDP is provided when the failing or non failing party of the penalty/claim is <del>neither</del><u>not</u> a CSD <del>nor a CCP</del> and its party type is CSD Participant.<b>{CR-806}</b></li> <li><input type="checkbox"/> EXTE is provided when the failing or non failing party of the penalty/claim is <del>neither</del><u>not</u> a CSD <del>nor a CCP</del> and its party type is an external CSD in T2S.<b>{CR-806}</b></li> </ul> |
| Counterparty                       |  |
| BIC of the CSD of the counterparty | Shows the CSD of the counterparty of the penalties reported in this block of the message.  |
| Counterparty BIC                   | Shows the BIC of the Party that manages the account on behalf of the counterparty account owner.   |
| Counterparty Type                  | Shows the BIC of the Party that manages the account on behalf of the counterparty account owner.<br>The possible values are: <ul style="list-style-type: none"> <li><input type="checkbox"/> NCSD</li> <li><input type="checkbox"/> <del>CCPA</del> <b>{CR-806}</b></li> <li><input type="checkbox"/> CSDP</li> <li><input type="checkbox"/> EXTE</li> </ul>   |
| Aggregated Amount                  | Shows the monthly aggregated net amount of all the penalties computed for the business days of the previous month, in the related currency for the relevant party and counterparty.  |
| Credit/Debit                       | Shows whether the Monthly Aggregated Net Amount is due or to be received by the participant.   |

| Report General Details |  |
|------------------------|--|
|                        | <p>The possible values are:</p> <ul style="list-style-type: none"> <li><input type="checkbox"/> DBIT(Debit)</li> <li><input type="checkbox"/> CRDT(Credit)</li> </ul> <p>If no value is retrieve, it will show “---”</p>   |
| <b>Penalty</b>         |  |
| Common ID              | Shows the reference assigned by T2S to the penalty that is common for both the failing and the non-failing participant.  |
| Individual ID          | Shows the reference assigned by T2S to the penalty that is the individual identification of the penalty for the relevant account owner.  |
| Reallocation ID        | Shows the Common Reference of either the penalty from which the reported penalty was re-allocated or the penalty to which the reported penalty has been re-allocated.  |
| Type                   | <p>Shows the type of the penalty.</p> <p>The possible values are:</p> <ul style="list-style-type: none"> <li><input type="checkbox"/> SEFP</li> <li><input type="checkbox"/> LMFP</li> </ul>   |
| Amount of the Penalty  | Shows the amount computed for the penalty and its corresponding currency.  |
| Credit/Debit Indicator | <p>Shows whether the penalty is due or to be received by the participant.</p> <p>The possible values are:</p> <ul style="list-style-type: none"> <li><input type="checkbox"/> DBIT(Debit)</li> <li><input type="checkbox"/> CRDT(Credit)</li> </ul>  |
| Calculation Method     | <p>Shows the calculation method used to calculate the penalty.</p> <p>The possible values are:</p> <ul style="list-style-type: none"> <li><input type="checkbox"/> SECU - The Penalty is based on the quantity of securities failed to be delivered and security penalty rate of the relevant Asset type.</li> </ul> |

| Report General Details |   |
|------------------------|---|
|                        | <ul style="list-style-type: none"> <li><input type="checkbox"/> MIXE - The Penalty is based on the quantity of securities failed to be delivered and penalty rate is the discount rate of the relevant currency.</li> <li><input type="checkbox"/> CASH - Penalty is based on the amount of cash failed to be delivered and the penalty rate is the discount rate of the relevant currency</li> <li><input type="checkbox"/> BOTH - Penalty is the sum of "SECU" and "CASH".</li> </ul> |
| Number of Days         | Shows the number of business days the penalty is applicable to.   |

## 2.4.1.24 Data Changes - Search/List Screen

### Context of Usage

This screen contains a number of search fields. By inputting the relevant data, you can search for all static and dynamic data changes which were initiated in 4-eyes mode. You can use this screen to search for items which are waiting for approval, select those and approve or revoke them.

The search results will be displayed in a list, which is sorted by the values of the column 'Update Date and Time' in descending order (default setting). After selecting an entry, you can proceed further by clicking on the buttons below.

This function is only available in U2A mode.

### Screen Access

- Services >> Additional Services >> Data Changes
- Securities >> Settlement >> Data Changes
- Cash >> Liquidity >> Data Changes

### Privileges

To use this screen you need the following privileges [▶ 880]:

- Data changes of a business object list query
- Data changes of a business object details query

### References

#### User Instructions Part

This screen is part of the following business scenarios:

- Initiate an action in 4-eyes mode
- Approve an action in 4-eyes mode

#### Business Functionality Document

This screen corresponds to the following business functions:

- Query data change approval requests (T2S.GUI.OSSE.APR.0010)
- Display data changes approval request list (T2S.GUI.OSSE.APR.0020)

**Screenshot**

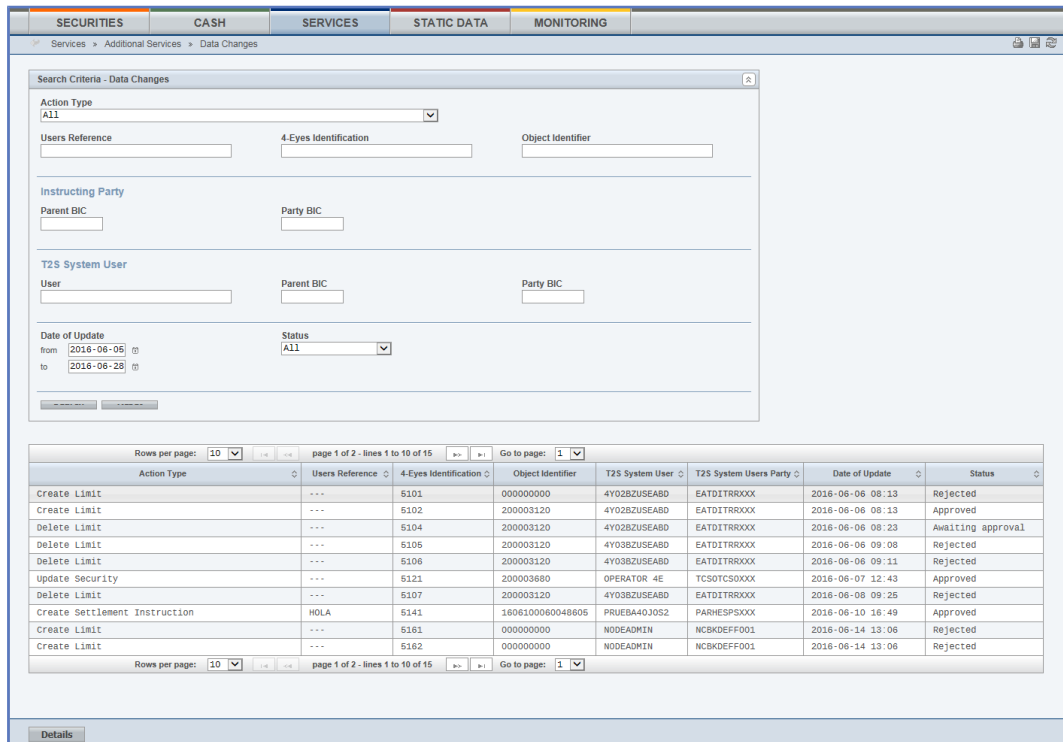

Illustration 116: Data changes – search/list screen

**Field Description**

| Data Changes – Search Criteria |   |
|--------------------------------|---|
| Action Type                    | Select the type of action initiated by the first user for a dedicated static or dynamic data object from the possible values:<br><br><input type="checkbox"/> All<br><br><input type="checkbox"/> Each of the actions that can be done in 4-eyes-mode |
| Users Reference                | Enter the identification the first user added to his request.<br>Required format is: max. 35 characters (SWIFT-x)   |
| 4-Eyes Identification          | Enter the identification of the data change, automatically assigned by T2S to an operation that has to be authorised by a second user.<br><br>Required format is: max. 35 characters (SWIFT-x)  |
| Object Identifier              | Enter the object identifier of the added / changed / deleted object. It is the technical identifier of an object unless a business identifier is available for this object.<br><br>Required format is: max. 35 characters (SWIFT-x)                   |
| Instructing Party              |   |
| Parent BIC                     | Enter the parent BIC of the instructing party.  |



| <b>Data Changes – Search Criteria</b> |   |
|---------------------------------------|---|
|                                       | <p>Required format is: max. 11 characters (SWIFT-x)</p> <p>If the 'Party BIC' field is filled in, this field is mandatory.</p> <p>This field is only filled for requests to 'Life Cycle Management and Matching' in 4-eyes mode.</p>  |
| Party BIC                             | <p>Enter the BIC of the instructing party.</p> <p>Required format is: max. 11 characters (SWIFT-x)</p> <p>If the 'Parent BIC' field is filled in, this field is mandatory.</p> <p>This field is only filled for requests to 'Life Cycle Management and Matching' in 4-eyes mode.</p>  |
| <b>Date of Update</b>                 |   |
| Date of Update - from                 | <p>Enter the lower bound of the date from which the data change was requested.</p> <p>Required format is: YYYY-MM-DD</p> <p>The default value is the current calendar date.</p> <p>References for error messages [ ▶ 967]:</p> <ul style="list-style-type: none"> <li><input type="checkbox"/> QMPC015</li> <li><input type="checkbox"/> QMPC016</li> </ul> |
| Date of Update - to                   | <p>Enter the upper bound of the date until which the data change was requested.</p> <p>Required format is: YYYY-MM-DD</p> <p>The default value is the current calendar date.</p> <p>Reference for error message [ ▶ 967]:</p> <ul style="list-style-type: none"> <li><input type="checkbox"/> QMPC015</li> </ul>  |
| <b>T2S System User</b>                |   |
| User                                  | Enter the name of the last user who entered, edited or deleted the static or dynamic data.  |
| Party BIC                             | <p>Enter the BIC of the party which the last user belongs to.</p> <p>Required format is: max. 11 characters (SWIFT-x)</p> <p>If the 'Parent BIC' field is filled in, this field is mandatory.</p>   |
| Parent BIC                            | <p>Enter the parent BIC of the party which the last user belongs to.</p> <p>Required format is: max. 11 characters (SWIFT-x)</p> <p>If the 'Party BIC' field is filled in, this field is mandatory.</p>   |

| Data Changes – Search Criteria |  |
|--------------------------------|--|
| Status                         | <p>Select the processing status of the data change from the possible values:</p> <ul style="list-style-type: none"> <li><input type="checkbox"/> All (Default value)</li> <li><input type="checkbox"/> Awaiting approval</li> <li><input type="checkbox"/> Queued</li> <li><input type="checkbox"/> Approved</li> <li><input type="checkbox"/> Rejected</li> <li><input type="checkbox"/> Revoked</li> </ul> |
| Data Changes - List            |  |
| Action Type                    | Shows the type of action, from all the actions that can be done in 4-eyes-mode, initiated by the first user for a dedicated static or dynamic data object.   |
| Users Reference                | Shows the identification by the first user added to his request.   |
| 4-Eyes Identification          | Shows the identification of the change automatically assigned by T2S to an operation that has to be authorised by a second user.   |
| Object Identifier              | Shows the object identification returned by the subsequent module after successful business validation. This information will not be displayed for all records.  |
| T2S System User                | Shows the name of the last user who entered, edited or deleted the static or dynamic data.   |
| T2S System User Party          | Shows the BIC of the party which the last user belongs to.   |
| Update Date and Time           | <p>Shows the timestamp when the first user entered, edited or deleted the static or dynamic data.</p> <p>Displayed format is: YYYY-MM-DD hh:mm:ss:µsµsµsµsµs</p>   |
| Status                         | <p>Shows the status of the data change from the possible values:</p> <ul style="list-style-type: none"> <li><input type="checkbox"/> Awaiting approval</li> <li><input type="checkbox"/> Queued</li> <li><input type="checkbox"/> Approved</li> <li><input type="checkbox"/> Rejected</li> <li><input type="checkbox"/> Revoked</li> </ul>   |

**Buttons**

| Search  | <p>This function enables you to start a search according to the criteria entered. The results are displayed in a list on the same screen.</p> <p>If the search retrieves only one record, the <i>details</i> screen is displayed directly.</p> <p>Next screens:</p> <ul style="list-style-type: none"> <li><input type="checkbox"/> <i>Data changes – search/list</i> screen</li> <li><input type="checkbox"/> <i>Data change – details</i> screen [▶ 611]</li> </ul> <p>References for error messages [▶ 967]:</p> <ul style="list-style-type: none"> <li><input type="checkbox"/> QMPC015</li> <li><input type="checkbox"/> QMPC016</li> </ul> |
|---------|--|
| Reset   | <p>This function enables you to set default search criteria and blanks out all optional criteria.</p> <p>Next screen:</p> <ul style="list-style-type: none"> <li><input type="checkbox"/> <i>Data changes – search/list</i> screen</li> </ul>  |
| Details | <p>This function enables you to display the details of the selected data change.</p> <p>Next screen:</p> <ul style="list-style-type: none"> <li><input type="checkbox"/> <i>Data change – details</i> screen [▶ 611]</li> </ul>  |

## 2.4.1.25 Data Change - Details Screen

**Context of Usage**

This screen displays detailed information on the selected static or dynamic data changes, changes are highlighted in red. You can check the data and proceed further by clicking on the buttons below.

You can use this screen for approving/revoking static and dynamic data changes and to see details of already approved/revoked items.

This function is only available in U2A mode.

**Screen Access**

- Services >> Additional Services >> Data Changes >> *Data changes – search/list* screen >> Click on the *search* and/or *details* button
- Securities >> Settlement >> Data Changes >> *Data changes – search/list* screen >> Click on the *search* and/or *details* button
- Cash >> Liquidity >> Data Changes >> *Data changes – search/list* screen >> Click on the *search* and/or *details* button

**Privileges**

To use this screen, you need the following privileges [▶ 880]:

- Data changes of a business object details query
- Data changes of a business object list query

**References**

**User Instructions Part**

This screen is part of the following business scenarios:

- Initiate an action in 4-eyes mode
- Approve an action in 4-eyes mode

**Business Functionality Document**

This screen corresponds to the following business functions:

- Display data change approval request details (T2S.GUI.OSSE.APR.0030)
- Data change approval request confirmation (T2S.GUI.OSSE.APR.0040)

**Screenshot**

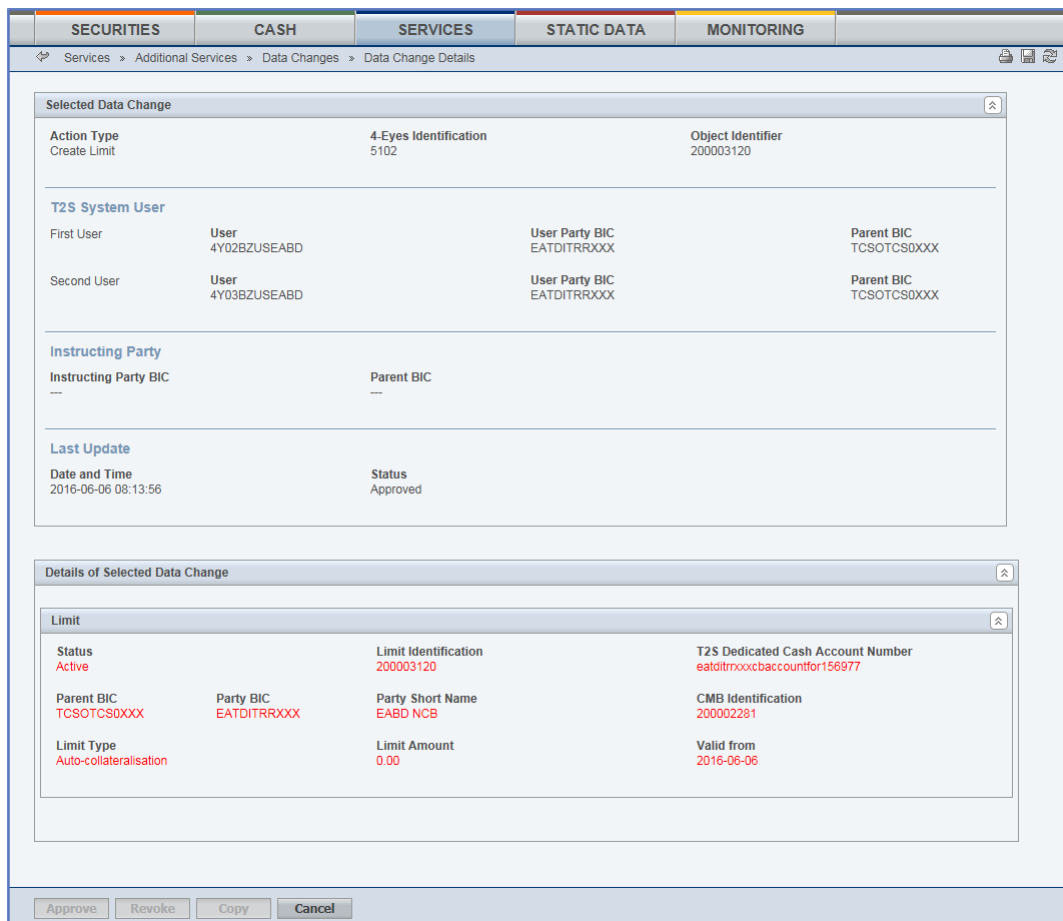

Illustration 117: Data change – details screen

**Field**

**Description**

| Selected Data Change  |  |
|-----------------------|--|
| Action Type           | Shows the type of action initiated by the first user.  |
| Users Reference       | Shows the identification the first user added to his request.                                      |
| 4-Eyes Identification | Shows the identification assigned by T2S to an operation that has to be approved by a second user. |

| Selected Data Change          |  |
|-------------------------------|--|
| Object Identifier             | Shows the object identification of the static or dynamic data object returned by the subsequent module after a successful business validation. The object identifier includes the technical identification of the added, changed or deleted object.<br><br>The object identification is not available for 'Life Cycle Management and Matching' data changes. |
| Instructing Party             |  |
| Instructing Party BIC         | Shows the BIC of the instructing party.<br><br>This field is only filled for requests to 'Life Cycle Management and Matching' in 4-eyes mode.  |
| Parent BIC                    | Shows the parent BIC of the instructing party.<br><br>This field is only filled for requests to 'Life Cycle Management and Matching' in 4-eyes mode.   |
| Date and Time                 | Shows the timestamp when the user has entered the data.<br><br>Displayed format is: YYYY-MM-DD hh:mm:ss:µsµsµsµsµs   |
| T2S System User – First User  |  |
| User                          | Shows the name of the first user who entered, edited or deleted the static or dynamic data.  |
| User Party BIC                | Shows the BIC of the party which the first user belongs to.  |
| Parent BIC                    | Shows the parent BIC of the party which the first user belongs to.   |
| T2S System User – Second User |  |
| User                          | Shows the name of the second user who entered, edited or deleted the static or dynamic data.   |
| User Party BIC                | Shows the BIC of the party which the second user belongs to.   |
| Parent Party                  | Shows the parent BIC of the party which the second user belongs to.  |
| Status                        | Shows the processing status of the data change from the possible values:<br><br><input type="checkbox"/> Awaiting approval<br><input type="checkbox"/> Queued<br><input type="checkbox"/> Approved<br><input type="checkbox"/> Rejected  |

| Selected Data Change  |   |
|---|---|
|   | <input type="checkbox"/> Revoked  |
| Details of Selected Data Change   |   |
| Shows a preview of the <i>details</i> screen of the object you are e.g. creating or editing.  |   |
| If the action type is set to 'New Data', this frame shows the new values which will be active after the second user approves the change.                  |   |
| If the action type is set to 'Edit Data', this frame shows the newly changed values marked in a different colour.   |   |
| If the action type is set to 'Delete Data', this frame shows the currently active values which will be deleted after the second user approves the change. |   |
| Immediate Liquidity Transfer (example)  |   |
| Debit Cash Account  |   |
| Account Number*   | Shows the T2S dedicated cash account to be debited.   |
| Account Owner*  | Shows the name of the account owner.  |
| Liquidity Transfer  |   |
| User Reference*   | Shows the identification of the liquidity transfer assigned by the T2S actor.   |
| Amount*   | Shows the amount of the initiated Immediate Liquidity Transfer.   |
| Credit Cash Account   |   |
| Outbound Liquidity Transfer   | Shows that the immediate liquidity transfer is an outbound liquidity transfer, if the radio button is checked.  |
| Internal Liquidity Transfer   | Shows that the immediate liquidity transfer is an internal liquidity transfer, if the radio button is checked.  |
| RTGS Account*   | Shows the cash account to be credited for the outbound liquidity transfer.<br><br>If the immediate liquidity transfer is an 'Internal Liquidity Transfer', this field is not filled and greyed out. |
| Account Number*   | Shows the cash account to be credited for the internal liquidity transfer.<br><br>If the immediate liquidity transfer is an 'Outbound Liquidity Transfer', this field is not filled and greyed out. |
| List of Modifications   |   |
| The List of Modifications may contain several entries   |   |

| Selected Data Change |   |
|----------------------|---|
| Field Name           | Name of the field, where the first user has changed data, entered new data or deleted data.                       |
| Old value            | The old value is the currently active value of the field before the second user approves the changes.             |
| New value            | The new value is the pending value of the field which will be active, after the second user approved the changes. |

## Buttons

| Approve | <p>This function enables you to approve the action initiated by the first user. In case non-repudiation of origin is required: Upon clicking on the <i>approve</i> button you will be asked to enter your PIN for digital signature purposes (NRO). With the entry of the PIN, T2S attaches a digital signature to the instruction entered by the T2S actor.</p> <p>Next screen:</p> <ul style="list-style-type: none"> <li><input type="checkbox"/> <i>Data changes – search/list</i> screen [ ▶ 607]</li> </ul> <p>This function is only available if the processing status of the data change is set to 'Awaiting Approval' and the T2S system user has the necessary privileges.</p> |
|---------|--|
| Revoke  | <p>This function enables you to revoke the action initiated by the first user. In case non-repudiation of origin is required: Upon clicking on the <i>revoke</i> button you will be asked to enter your PIN for digital signature purposes (NRO). With the entry of the PIN, T2S attaches a digital signature to the instruction entered by the T2S actor.</p> <p>Next screen:</p> <ul style="list-style-type: none"> <li><input type="checkbox"/> <i>Data changes – search/list</i> screen [ ▶ 607]</li> </ul> <p>This function is only available if the processing status of the data change is set to 'Awaiting Approval' and the T2S system user has the necessary privileges.</p>   |
| Copy    | <p>This function enables you to copy fields to create a new data change with the same attributes.</p>  |

|        |   |
|--------|---|
|        | <p>Next screen:</p> <ul style="list-style-type: none"> <li><input type="checkbox"/> <i>Respective new/edit</i> screen (filled with the values formerly entered by the first user.)</li> </ul> <p>This function is only available if the processing status of the data change is set to 'Revoked' or 'Rejected'.</p> |
| Cancel | <p>This function enables you to cancel the process and return to the previous screen.</p> <p>Next screen:</p> <ul style="list-style-type: none"> <li><input type="checkbox"/> <i>Data changes – search/list</i> screen [ ▶ 607]</li> </ul>  |

## 2.4.2 Communication

### 2.4.2.1 Broadcast - Search/List Screen

#### Context of Usage

This screen contains a number of search fields. By inputting the relevant data, you can search for sent and received broadcasts. The search result will be displayed in a list, which is sorted by the values of the 'Creation Date and Time' column in descending order (default setting). After selecting an entry, you can proceed further by clicking on the buttons below.

When exporting the content of this screen, you receive the list and the corresponding details for each data record.

This function is only available in U2A mode.

There is no usage restriction for this screen.



#### Hint

A user may only view broadcasts until their validity elapses. The respective expiration date is automatically set to the current business date of creation + three business days.

#### Screen Access

Services >> Communication >> Broadcasts

#### Privileges

To use this screen, you need the following privilege [ ▶ 876]:

- Broadcast query
- New broadcast

#### References

##### User Instructions Part

This screen is part of the following business scenarios:

- Create a new broadcast [ ▶ 665]



- View a broadcast [▶ 666]

**Business Functionality Document**

This screen corresponds to no business function.

**Screenshot**

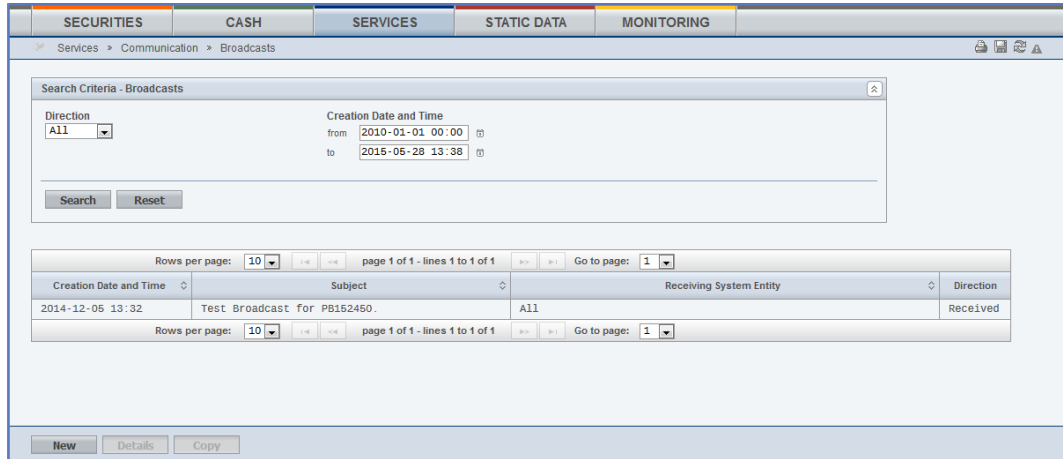

Illustration 118: Broadcasts - search/list screen

**Field Description**

| Broadcasts – Search Criteria |   |
|------------------------------|---|
| Direction*                   | Select the information about the direction of the broadcast from the possible values:<br><input type="checkbox"/> All (default value)<br><input type="checkbox"/> Sent<br><input type="checkbox"/> Received   |
| Creation Date and Time from  | Enter the lower bound of the search range for the date and time from which the broadcasts shall be displayed or use the <i>calendar</i> icon.<br>Required format is: YYYY-MM-DD hh:mm:ss<br>The 'Creation Date and Time from' has to be a valid calendar date and time.<br>Reference for error message [▶ 956]:<br><input type="checkbox"/> QMPC015   |
| Creation Date and Time to*   | Enter the upper bound of the search range for the date and time until which the broadcasts shall be displayed or use the <i>calendar</i> icon.<br>The default value is the current calendar date and time. In case the 'Creation Date and Time to' is removed the search will be executed with the default value.<br>Required format is: YYYY-MM-DD hh:mm:ss<br>The 'Creation Date and Time to' has to be a valid calendar date and time. |

| Broadcasts – Search Criteria |   |
|------------------------------|---|
|                              | Reference for error message [ ▶ 956]:<br><input type="checkbox"/> QMPC015   |
| Broadcasts - List            |   |
| Creation Date and Time       | Shows the creation date and time when the broadcasts was posted.<br>Displayed format is: YYYY-MM-DD hh:mm:ss:µsµsµsµsµs   |
| Subject                      | Shows the title of the broadcast.   |
| Direction                    | Shows detailed information about the direction from the possible values:<br><input type="checkbox"/> All<br><input type="checkbox"/> Sent<br><input type="checkbox"/> Received  |
| Receiving Party BIC          | This function enables you to start a search according to the criteria entered. The results are displayed in a list on the same screen.<br>If the search retrieves a single record, the details screen is displayed.<br>Next screen:<br><input type="checkbox"/> Broadcasts – search/list screen<br><input type="checkbox"/> Broadcast – details screen [ } 179]<br>Reference for error message:<br><input type="checkbox"/> QMPC015 |

## Buttons

|         |  |
|---------|--|
| Reset   | This function enables you to set default search criteria and blanks out all optional criteria.<br>Next screen:<br><i>Broadcasts – search/list</i> screen |
| Details | This function enables you to display details of the selected broadcast.<br>Next screen:<br><i>Broadcast – details</i> screen [ ▶ 619]                    |
| New     | This function enables you to create a new broadcast.   |

|      |  |
|------|--|
|      | Next screen:<br><i>Broadcast – new screen</i> [▶ 621]  |
| Copy | This function enables you copy fields to create a new broadcast with the same attributes.<br>Next screen:<br><i>Broadcast – new screen</i> [▶ 621] |

## 2.4.2.2 Broadcast - Details Screen

|                         |  |
|-------------------------|--|
| <b>Context of Usage</b> | <p>This screen displays detailed information on the selected broadcast. You can check the data and proceed further by clicking on the buttons below.</p> <p>This function is only available in U2A mode.</p> <p>There is no usage restriction for this screen.</p>   |
| <b>Screen Access</b>    | <ul style="list-style-type: none"><li>□ Services &gt;&gt; Communication &gt;&gt; Broadcasts &gt;&gt; <i>Broadcasts – search/list</i> screen &gt;&gt; Click on the <i>details</i> button</li><li>□ Services &gt;&gt; Communication &gt;&gt; Broadcasts &gt;&gt; <i>Broadcasts – search/list</i> screen &gt;&gt; Click on the <i>search</i> button</li></ul> |
| <b>Privileges</b>       | <p>To use this screen, you need the following privilege [▶ 875]:</p> <ul style="list-style-type: none"><li>□ Broadcast query</li></ul>   |
| <b>References</b>       | <p><b>User Instructions Part</b></p> <p>This screen is part of the following business scenario:</p> <ul style="list-style-type: none"><li>□ View a broadcast [▶ 666]</li></ul> <p><b>Business Functionality Document</b></p> <p>This screen corresponds to no business function.</p>   |

**Screenshot**

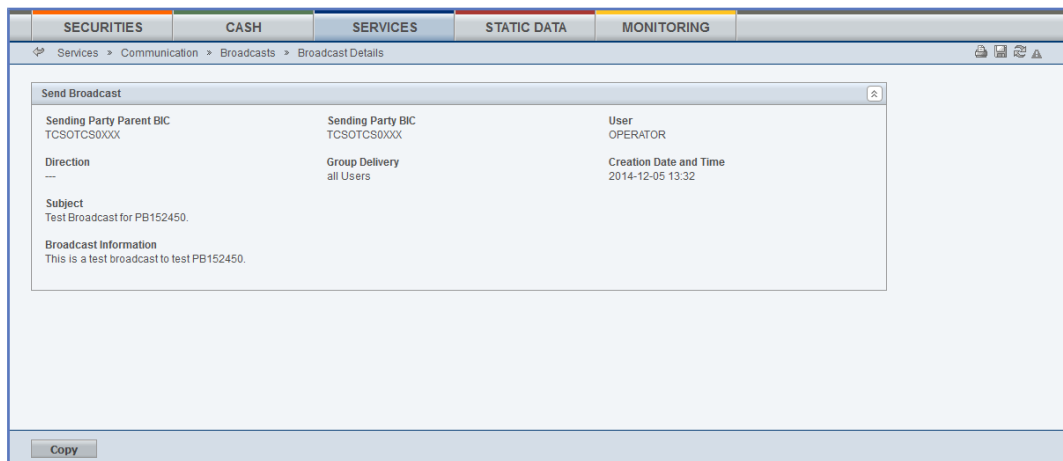

Illustration 119: Broadcast – details screen

**Field Description**

| Broadcast – Details      |   |
|--------------------------|---|
| Sending Party Parent BIC | Shows the parent BIC of the sending party.  |
| Sending Party BIC        | Shows the BIC of the sending party.   |
| User                     | Shows the initiating T2S system user.   |
| Direction                | Shows whether the broadcast status is received, sent or both from of possible values:<br><input type="checkbox"/> Received<br><input type="checkbox"/> Sent |
| Group Delivery           | Shows the group which the broadcast has been delivered to.  |
| Creation Date and Time   | Shows the creation date and time of the broadcast.<br>Displayed format is: YYYY-MM-DD hh:mm:ss:µsµsµsµsµsµs   |
| Subject                  | Shows the title of the broadcast.   |
| Broadcast Information    | Shows the detailed content of the broadcast.  |

**Buttons**

|      |   |
|------|---|
| Copy | This function enables you copy fields to create a new broadcast with the same attributes.<br>Next screen:<br><input type="checkbox"/> <i>Broadcast – new screen</i> [▶ 621] |
|------|---|

### 2.4.2.3 Broadcast - New Screen

**Context of Usage**

This screen contains a number of fields regarding broadcasts. You can enter new data. Afterwards you can proceed further by clicking on the buttons below and send manual broadcasts to your CB/CSD and, all parties in your hierarchy.

This function is only available in U2A mode.

There is no usage restriction for this screen.

**Screen Access**

- Services >> Communication >> Broadcasts >> *Broadcast – search/list* screen >> Click on the *new* button
- Services >> Communication >> Broadcasts >> *Broadcast – search/list* screen >> Click on the *copy* button
- Services >> Communication >> Broadcasts >> *Broadcasts – search/list* screen >> Click on the *search* and/or *details* button >> *Broadcast – details* screen >> Click on the *copy* button

**Privileges**

To use this screen, you need the following privilege [▶ 875]:

- New broadcast

**References**

**User Instructions Part**

This screen is part of the following business scenario:

- Create a new broadcast [▶ 665]

**Business Functionality Document**

This screen corresponds to no business function.

**Screenshot**

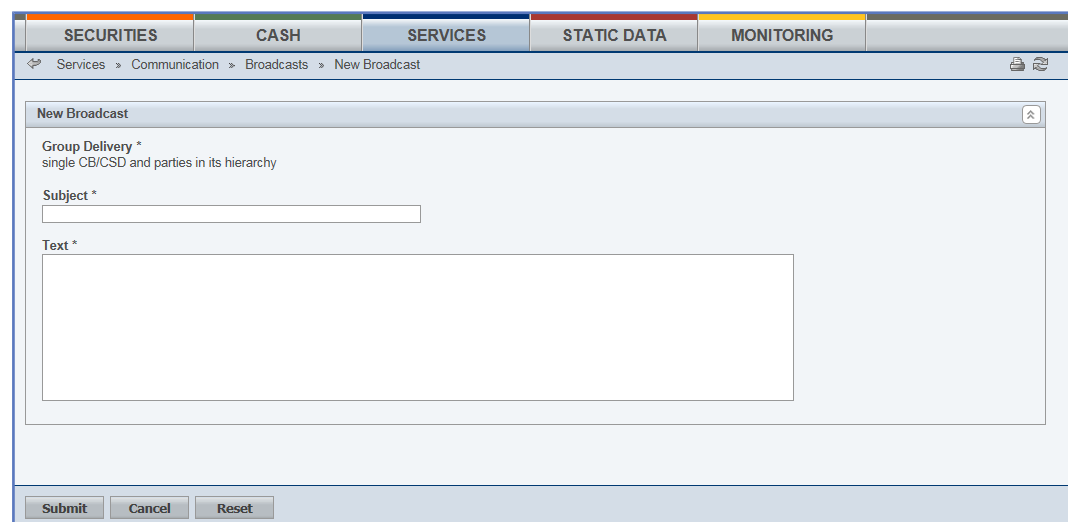

Illustration 120: Broadcast - new screen

**Field**

**Description**

| Broadcast - New |   |
|-----------------|---|
| Group Delivery* | Shows the receiving party: <ul style="list-style-type: none"> <li><input type="checkbox"/> This field is always filled in with 'Single</li> <li><input type="checkbox"/> CB/CSD and parties in its hierarchy</li> </ul> |

| Broadcast - New |   |
|-----------------|---|
| Subject*        | Enter the title of the broadcast.<br>Required format is: max. 50 characters (SWIFT-x)             |
| Text*           | Enter the message content of the broadcast.<br>Required format is: max. 1000 characters (SWIFT-x) |

**Buttons**

| Buttons |   |
|---------|---|
| Submit  | This function enables you to create a new broadcast. Upon clicking on the <i>submit</i> button you will be asked to enter your PIN for digital signature purposes (NRO). With the entry of the PIN, T2S attaches a digital signature to the instruction entered by the T2S actor.<br><br>Next screen:<br><input type="checkbox"/> <i>Broadcast – new</i> screen |
| Reset   | This function enables you to set all fields to default value and blanks out all optional fields.<br><br>Next screen:<br><input type="checkbox"/> <i>Broadcast – new</i> screen  |
| Cancel  | This function enables you to cancel the process and return to the previous screen.<br><br>Next screen:<br><input type="checkbox"/> <i>Broadcasts – search/list</i> screen [▶ 616]   |

## 2.4.2.4 Inbound Files - Search/List Screen

**Context of Usage**

This screen contains a number of search fields. By inputting the relevant data, you can search for inbound files. The search results will be displayed in a list, which is sorted by the values of the 'Entry Date and Time' column in descending order (default setting). After selecting an entry, you can proceed further by clicking on the buttons below. Users can see Inbound Messages under their data-scope.

This function is only available in U2A mode.

There is no usage restriction for this screen.

**Screen Access**

*Services >> Communication >> Inbound Files*

**Privileges**

To use this screen, you need the following privilege [▶ 884]:

*Inbound files list query*

References

User Instructions Part

This screen is part of the following business scenario:

- View inbound communication [▶ 668]

Business Functionality Document

This screen corresponds to the following business functions:

- Query inbound file (T2S.GUI.CCSE.FIL.0010)
- Display inbound file list (T2S.GUI.CCSE.FIL.0020)

Screenshot

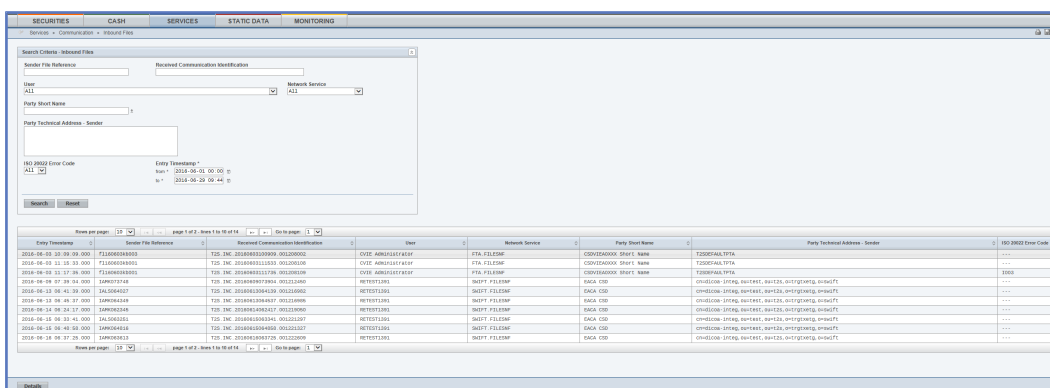

Illustration 121: Inbound files – search/list screen

Field Description

| Inbound Files – Search Criteria |   |
|---------------------------------|---|
| Sender File Reference           | Enter the identification of the original file containing the messages.<br><br>Required format is: max. 35 characters (SWIFT-x)  |
| Received Communication          | Enter the internal identification for the inbound communication assigned by T2S.<br><br>Required format is: max. 50 characters (SWIFT-x)  |
| User                            | Enter or select the user who initiated the communication under the data scope of the requestor.<br><br>Required format is: max. 35 characters.<br><br>All available users which you are privileged to see are listed.               |
| Network Service                 | Select the network service from the drop-down menu.   |
| Sending Party Short Name        | Enter or select the short name of the business sending party under the data scope of the requestor.<br><br>Required format is: max. 35 characters.<br><br>All available sending parties which you are privileged to see are listed. |
| Party Technical Address         | Enter the technical address (i.e. distinguished name) of the party.   |

| Inbound Files – Search Criteria                              |  |
|--|--|
|  | Required format is: max. 256 characters in UTF-8 except '<', '>', '&'  |
| ISO 20022 Error Code   | Select the error code for rejection from the drop-down menu.   |
| Entry Date and Time from*                                    | <p>Enter the lower bound of the search range for the calendar date and time from which the inbound file entered the system or use the <i>calendar</i> icon.</p> <p>Required format is: YYYY-MM-DD hh:mm:ss</p> <p>Default value is the current calendar date and time.</p> <p>The 'Entry Date and Time from' date must be earlier than or equal to the current business date and earlier than the 'Entry Date and Time to' date.</p> <p>References for error messages: [ ▶ 992]</p> <ul style="list-style-type: none"> <li><input type="checkbox"/> QMPC015</li> <li><input type="checkbox"/> QMPC073</li> </ul> |
| Entry Date and Time to*                                      | <p>Enter the upper bound of the search range for the calendar date and time until which the inbound file entered the system or use the <i>calendar</i> icon.</p> <p>Required format is: YYYY-MM-DD hh:mm:ss</p> <p>Default value is the current calendar date and time.</p> <p>The 'Entry Date and Time to' date must be later than the 'Entry Date and Time from' date.</p> <p>Reference for error message: [ ▶ 992]</p> <ul style="list-style-type: none"> <li><input type="checkbox"/> QMPC015</li> </ul>   |
| Inbound Files – List   |  |
| Repetitive block for each business object of an inbound file |  |
| Entry Date and Time  | <p>Shows the calendar date and time when the inbound file entered T2S.</p> <p>Displayed format is: YYYY-MM-DD hh:mm:ss:μsμsμsμsμs</p>  |
| Sender File Reference  | Shows the identification of the original file.   |
| Received Communication                                       | Shows the internal identification for the inbound communication assigned by T2S.   |
| User   | Shows the user who initiated the communication.  |
| Network Service  | Shows the name of the network service.   |



| Inbound Files – Search Criteria |  |
|---------------------------------|--|
| Sending Party Short Name        | Shows the short name of the business sending party.  |
| Party Technical Address         | Shows the technical address (i.e. distinguished name) of the party.<br><br>Displayed format is: max. 256 characters in UTF-8 except '<' ;'>','&' |
| ISO20022 Error Code             | Shows the error code for the rejection.<br><br>In case of more than one error, this field shows 'various'.                                       |

## Buttons

| Buttons |  |
|---------|--|
| Search  | This function enables you to start a search according to the criteria entered. The results are displayed in a list on the same screen.<br><br>If the search retrieves a single record, the <i>details</i> screen is displayed directly.<br><br>Next screens: <ul style="list-style-type: none"><li><input type="checkbox"/> <i>Inbound files – search/list</i> screen</li><li><input type="checkbox"/> <i>Inbound file – details</i> screen [▶ 625]</li></ul> References for error messages: [▶ 992] <ul style="list-style-type: none"><li><input type="checkbox"/> QMPC015</li><li><input type="checkbox"/> QMPC073</li></ul> |
| Reset   | This function enables you to set default search criteria and blanks out all optional criteria.<br><br>Next screen: <ul style="list-style-type: none"><li><input type="checkbox"/> <i>Inbound files – search/list</i> screen</li></ul>  |
| Details | This function enables you to display the details of the selected inbound file.<br><br>Next screen: <ul style="list-style-type: none"><li><input type="checkbox"/> <i>Inbound file – details</i> screen [▶ 625]</li></ul>   |

## 2.4.2.5 Inbound File - Details Screen

### Context of Usage

This screen displays detailed information on the selected inbound file. You can check the data and proceed further by clicking on the button below.

There is no usage restriction for this screen.

This function is only available in U2A mode.

**Screen Access**

- Services >> Communication >> Inbound Files >> *Inbound files – search/list* screen >> Click on the *search* and/or *details* button
- Services >> Communication >> Inbound Messages >> *Inbound messages – search/list* screen >> Click on the *inbound file* button
- Services >> Communication >> Inbound Messages >> *Inbound messages – search/list* screen >> Click on the *search* and/or *details* button >> *Inbound message – details* screen >> Click on the *inbound file* button

**Privileges**

To use this screen, you need the following privilege [[▶ 884](#)]:

- Inbound files details query

**References**

**User Instructions Part**

This screen is part of the following business scenario:

- View inbound communication [[▶ 668](#)]

**Business Functionality Document**

This screen corresponds to the following business functions:

- Display inbound file details (T2S.GUI.CCSE.FIL.0030)

**Screenshot**

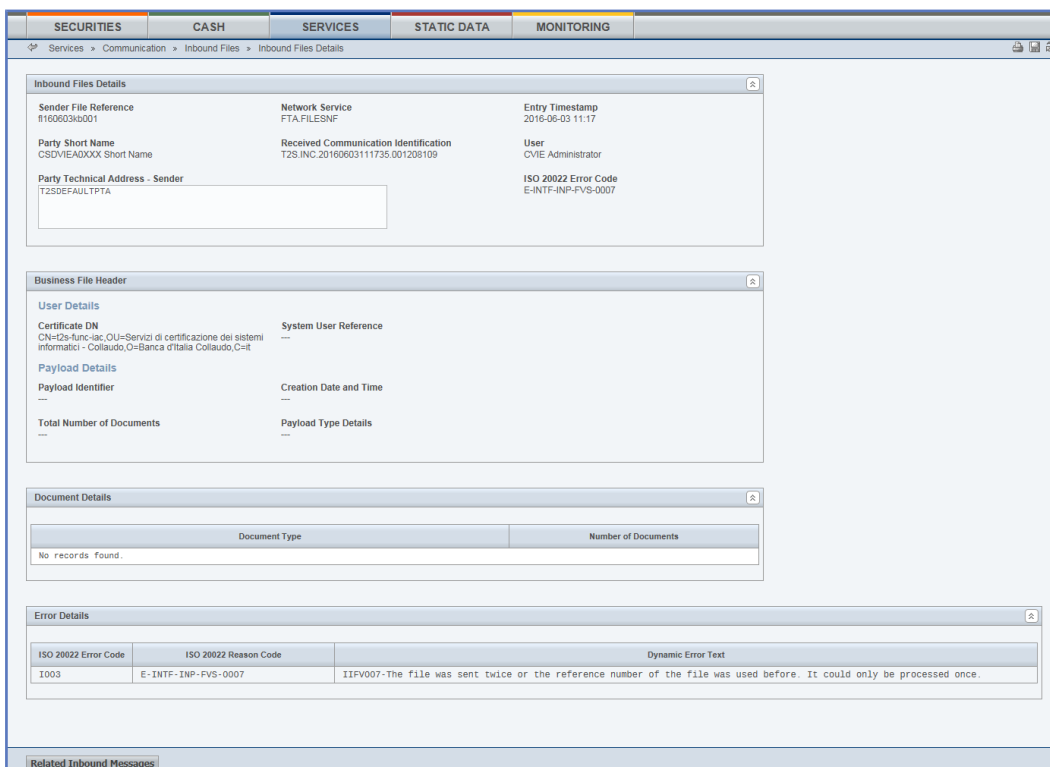

Illustration 122: Inbound file - details screen

**Field Description**

| Inbound Files Details Information |  |
|-----------------------------------|--|
| Sender File Reference             | Shows the identification of the original file containing the messages. |

| Inbound Files Details Information                                     |   |
|---|---|
| Network Service   | Shows the name of the network service.  |
| Entry Date and Time   | Shows the calendar date and time when the file entered T2S.<br>Displayed format is: YYYY-MM-DD hh:mm:ss:µsµsµsµsµs      |
| Sending Party Short Name  | Shows the short name of the business sending party.   |
| Received Communication  | Shows the identification for the inbound communication assigned by T2S.   |
| User  | Shows the user who initiated the communication.   |
| Party Technical Address   | Shows the technical address (i.e. distinguished name) of the party.   |
| ISO 20022 Error Code  | Shows the ISO 20022 error code.   |
| <b>Business File Header</b>   |   |
| <b>User Information</b>   |   |
| Certificate Distinguished Name  | Shows the user information which was extracted from the signature tag in the file header.                               |
| System User Reference   | Shows the identification of the system user which was extracted from the file header.                                   |
| <b>Payload Details</b>  |   |
| Payload Identifier  | Shows the identification of the file which was assigned by the sender of the file.                                      |
| Creation Date and Time  | Shows the date and time when the file was created by the sender.<br>Displayed format is: YYYY-MM-DD hh:mm:ss:µsµsµsµsµs |
| Total Number of Documents   | Shows the total number of messages within the file.   |
| Payload Type Details  | Shows the identification of the payload type and the declaration of the payload content.                                |
| <b>Document Details</b>   |   |
| <b>(Repetitive block for each business object of an inbound file)</b> |   |
| Document Type   | Shows the type of the document as specified in the ISO 20022 message type catalogue.                                    |
| Number of Documents   | Shows the number of messages for each declared type.  |

| Inbound Files Details Information                             |   |
|---|---|
| <b>Error Details</b>  |   |
| <b>(Repetitive block for each message of an inbound file)</b> |   |
| ISO 20022 Error Code  | Shows the error code for the rejection.                           |
| ISO 20022 Reason Code   | Shows the reason code for the rejection.                          |
| Dynamic Error Text  | Shows a detailed error text explaining why the file was rejected. |

**Buttons**

| Related Inbound Messages | <p>This function enables you to display the inbound messages related to the selected inbound file.</p> <p>Next screens:</p> <ul style="list-style-type: none"> <li><input type="checkbox"/> <i>Inbound messages – search/list</i> screen [▶ 628] (if the inbound file is linked to more than 1 inbound message)</li> <li><input type="checkbox"/> <i>Inbound message – details</i> screen [▶ 635] (if the inbound file is linked to 1 inbound message only)</li> </ul> |
|--------------------------|--|

## 2.4.2.6 Inbound Messages - Search/List Screen

**Context of Usage**

This screen contains a number of search fields. By inputting the relevant data, you can search for inbound messages. The search results will be displayed in a list, which is sorted by the values of the 'Entry Date and Time' column in descending order (default setting). After selecting an entry, you can proceed further by clicking on the buttons below. Users can see Inbound Messages under their datascopes.

This screen shows all inbound messages irrespective of whether they were sent via file or as single message.

There is no usage restriction for this screen.

This function is only available in U2A mode.

**Screen Access**

- Services >> Communication >> Inbound Message
- Services >> Communication >> Inbound Files >> *Inbound files – search/list* screen >> Click on the *search* and/or *details* button >> *Inbound file – details* screen >> Click on the *related inbound messages* button
- Cash >> Liquidity >> Immediate Liquidity Transfers >> *Immediate liquidity transfers – search/list* screen >> Click on the *related inbound messages* button

- Cash >> Liquidity >> Immediate Liquidity Transfers >> *Immediate liquidity transfers – search/list* screen >> Click on the *search* and/or *details* button >> *Immediate liquidity transfer – details* screen >> Click on the *related inbound messages* button
- Cash >> Settlement >> Intra-Balance Movement >> *Intra-balance movements with current and historical status – search* screen >> Click on the *search* button >> *Intra-balance movements - list* screen >> Click on the *details* button >> *Intra-balance movement – details* screen >> Click on the *related inbound message* button
- Cash >> Settlement >> Maintenance Cash Instructions >> *Maintenance cash instructions – search* screen >> Click on the *search* button >> *Maintenance cash instructions - list* screen >> Click on the *details* button >> *Amendment cash instruction - details* screen >> Click on the *related inbound message* button
- Cash >> Settlement >> Maintenance Cash Instructions >> *Maintenance cash instructions – search* screen >> Click on the *search* button >> *Maintenance cash instructions – list* screen >> Click on the *details* button >> *Cancellation cash instruction - details* screen >> Click on the *related inbound message* button
- Security >> Settlement >> Intra-Position Movement >> *Intra-position movements with current and historical status – search* screen >> Click on the *search* button >> *Intra-position movements - list* screen >> Click on the *details* button >> *Intra-position movement – details* screen >> Click on the *related inbound message* button
- Securities >> Settlement >> Maintenance Securities Instructions >> *Maintenance securities instructions – search* screen >> Click on the *search* button >> *Maintenance securities instruction - list* screen >> Click on the *details* button >> *Amendment securities instruction - details* screen >> Click on the *related inbound message* button
- Securities >> Settlement >> Maintenance Securities Instructions >> *Maintenance securities instructions – search* screen >> Click on the *search* button >> *Maintenance securities instructions – list* screen >> Click on the *details* button >> *Cancellation securities instruction - details* screen >> Click on the *related inbound message* button
- Securities >> Settlement >> Maintenance Securities Instructions >> *Maintenance securities instructions – search* screen >> Click on the *search* button >> *Maintenance securities instructions – list* screen >> Click on the *details* button >> *Hold/release instruction - details* screen >> Click on the *related inbound message* button

- Securities >> Settlement >> Settlement Instructions>> **Settlement Instructions – search** screen >> Click on the **search** button >> **Settlement instructions - list** screen >> Click on **details** button >> **Settlement instruction - details** screen >> Click on the **related inbound messages** button

**Privileges**

To use this screen, you need the following privilege [▶ 885]:

- Inbound message list query

**References**

**User Instructions Part**

This screen is part of the following business scenario:

- View inbound communication [▶ 668]

**Business Functionality Document**

This screen corresponds to the following business functions:

- Query messages (T2S.GUI.CCSE.MSG.0010)
- Query inbound file (T2S.GUI.CCSE.FIL.0010)
- Display message list (T2S.GUI.CCSE.MSG.0020)

**Screenshot**

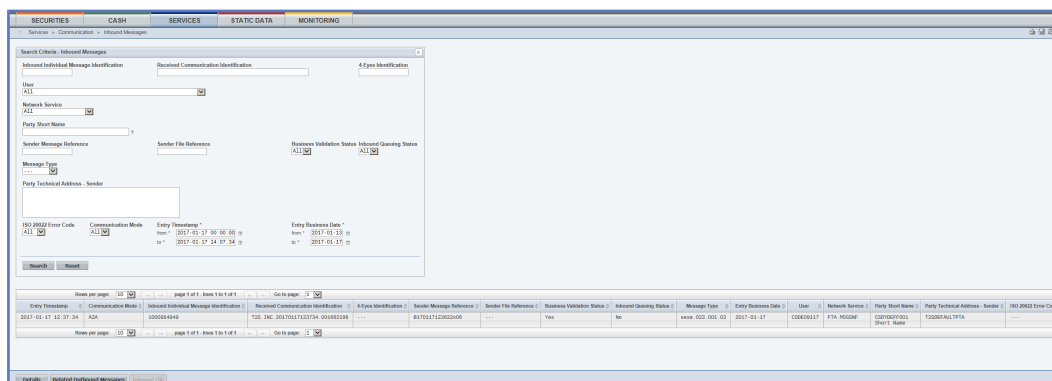

Illustration 123: Inbound messages – search/list screen

**Field Descriptions**

| Inbound Messages – Search Criteria    |   |
|---------------------------------------|---|
| Inbound Individual Message            | Enter the identification of the inbound individual message.<br>Required format is: Integer  |
| Received Communication Identification | Enter the technical identification for the inbound communication assigned by T2S.<br>Required format is: max. 50 characters (SWIFT-x)   |
| 4-Eyes Identification                 | Enter the identification of the 4-eyes mode.<br>Required format is: Integer   |
| User                                  | Enter or select the user who initiated the communication under the data scope of the requestor.<br>Required format is: max. 35 characters.<br>All available users which you are privileged to see are listed. |

| Inbound Messages – Search Criteria |  |
|------------------------------------|--|
| Network Service                    | Select the network service from the drop-down menu.  |
| Sending Party Short Name           | Select the short name of the sending party from the drop-down menu.<br><br>All available sending parties which you are privileged to see are listed.   |
| Sender Message Reference           | Enter the identification of the original message as sent in the business application header.<br><br>Required format is: max. 35 characters (SWIFT-x)   |
| Sender File Reference              | Enter the identification of the original file containing the message(s).<br><br>Required format is: max. 35 characters (SWIFT-x)   |
| Business Validation Status*        | Select the status of the business validation from the possible values:<br><br><input type="checkbox"/> True (business validation completed)<br><input type="checkbox"/> False (business validation incomplete)<br><input type="checkbox"/> All (default value) |
| Inbound Queuing Status*            | Select the status of the inbound queuing from the possible values:<br><br><input type="checkbox"/> True (request is currently queued)<br><input type="checkbox"/> False (request is not queued)<br><input type="checkbox"/> All (default value)                |
| Message Type                       | Select the request type for the message according to ISO 20022 standards from the drop-down menu.  |
| Party Technical Address - Sender   | Enter the technical address (i.e. distinguished name) of the sending party.<br><br>Required format is: max. 256 characters in UTF-8 except '<'; '>'; '&'   |
| ISO 20022 Error Code               | Select the error code for the rejection from the drop-down menu.   |
| Communication Mode*                | Select the mode of communication from the possible values:<br><br><input type="checkbox"/> A2A<br><input type="checkbox"/> U2A<br><input type="checkbox"/> All (default value)   |

| Inbound Messages – Search Criteria |  |
|------------------------------------|--|
| Entry Date and Time from(*)        | <p>Enter the lower bound of the search range for the calendar date and time of the system entry of the inbound message or use the <i>calendar</i> icon.</p> <p>Required format is: YYYY-MM-DD hh:mm:ss</p> <p>Default value is the current date and time – start of real-time settlement if the ‘Inbound Individual Message’ or the ‘Received Communication Identification’ is not populated from the previous screen.</p> <p>The ‘Entry Date and Time from’ date must be earlier than or equal to the current business date and earlier than the ‘Entry Date and Time to’ date.</p> <p>Reference for error message: [▶ 992]</p> <p><input type="checkbox"/> QMPC015</p> |
| Entry Date and Time to(*)          | <p>Enter the upper bound of the search range for the calendar date and time of the system entry of the inbound message or use the <i>calendar</i> icon.</p> <p>Required format is: YYYY-MM-DD hh:mm:ss</p> <p>Default value is the current date and time if the ‘Inbound Individual Message’ or the ‘Received Communication Identification’ is not populated from the previous screen.</p> <p>The ‘Entry Date and Time to’ date must be later than the ‘Entry Date and Time from’ date.</p> <p>Reference for error message: [▶ 992]</p> <p><input type="checkbox"/> QMPC015</p>  |
| Entry Business Date from(*)        | <p>Enter the lower bound of the search range for the business date of the message entry or use the <i>calendar</i> icon.</p> <p>Required format is: YYYY-MM-DD</p> <p>Default value is the current business date -1 if the ‘Inbound Individual Message’ or the ‘Received Communication Identification’ is not populated from the previous screen.</p> <p>The ‘Entry Date from’ date must be earlier than or equal to the current business date and earlier than the ‘Entry Date to’ date.</p> <p>Reference for error message: [▶ 992]</p> <p><input type="checkbox"/> QMPC073</p>  |



| Inbound Messages – Search Criteria  |   |
|---|---|
| Entry Business Date to(*)   | <p>Enter the upper bound of the search range for the business date of the message entry or use the <i>calendar</i> icon.</p> <p>Required format is: YYYY-MM-DD</p> <p>Default value is the current business date if the 'Inbound Individual Message' or the 'Received Communication Identification' is not populated from the previous screen.</p> <p>The 'Entry Date to' date must be later than the 'Entry Date from' date.</p> |
| <p>Inbound Messages – List</p> <p>Repetitive block for each business object of an inbound message</p> |   |
| Entry Date and Time   | <p>Shows the calendar date and time when the inbound message entered T2S.</p> <p>Displayed format is: YYYY-MM-DD hh:mm:ss:µsµsµsµsµs</p>  |
| Communication Mode  | <p>Shows the mode of communication from the possible values:</p> <ul style="list-style-type: none"> <li><input type="checkbox"/> U2A</li> <li><input type="checkbox"/> A2A</li> </ul>   |
| Inbound Individual Message  | Shows the identification of the individual message.   |
| Received Communication Identification   | Shows the internal generated identification for the inbound communication.  |
| 4-Eyes Identification   | Shows the identification of the 4-eyes mode which is only used in case of an approval request in 4-eyes mode.   |
| Sender Message Reference  | Shows the identification of the original message sent in the business application header.   |
| Sender File Reference   | Shows the identification of the original file containing the message.   |
| Business Validation Status  | <p>Shows the business validation status from the possible values:</p> <ul style="list-style-type: none"> <li><input type="checkbox"/> True (business validation successful)</li> <li><input type="checkbox"/> False (business validation finished with error)</li> </ul>  |
| Inbound Queuing Status  | <p>Shows the inbound queuing status from the possible values:</p> <ul style="list-style-type: none"> <li><input type="checkbox"/> True (request is currently queued)</li> </ul>   |

| Inbound Messages – Search Criteria |  |
|------------------------------------|--|
|                                    | <input type="checkbox"/> False (request is not queued)   |
| Message Type                       | Shows the message type according to the ISO 20022 standard.  |
| Entry Business Date                | Shows the business date when T2S received the message.<br>Displayed format is: YYYY-MM-DD                            |
| User                               | Shows the user who initiated the communication.  |
| Network Service                    | Shows the name of the network service.   |
| Sending Party Short Name           | Shows the short name of the business sending party.  |
| Party Technical Address - Sender   | Shows the technical address of the sender.<br>Displayed format is: max. 256 characters in UTF-8 except '<'; '>'; '&' |
| ISO 20022 Error Code               | Shows the error code for the rejection.  |

## Buttons

| Search                    | <p>This function enables you to start a search according to the criteria entered. The results are displayed in a list on the same screen.</p> <p>If the search retrieves a single record, the <i>details</i> screen is displayed directly.</p> <p>Next screens:</p> <ul style="list-style-type: none"> <li><input type="checkbox"/> <i>Inbound messages – search/list</i> screen</li> <li><input type="checkbox"/> <i>Inbound message – details</i> screen [▶ 635]</li> </ul> <p>References for error messages: [▶ 992]</p> <ul style="list-style-type: none"> <li><input type="checkbox"/> QMPC015</li> <li><input type="checkbox"/> QMPC073</li> </ul> |
|---------------------------|--|
| Reset                     | <p>This function enables you to set default search criteria and blanks out of all optional criteria.</p> <p>Next screen:</p> <ul style="list-style-type: none"> <li><input type="checkbox"/> <i>Inbound messages – search/list</i> screen</li> </ul>   |
| Related Outbound Messages | <p>This function enables you to display the outbound messages related to the selected inbound message.</p> <p>Next screens:</p>  |

|              |  |
|--------------|--|
|              | <ul style="list-style-type: none"> <li><input type="checkbox"/> <i>Outbound messages – search/list</i> screen [ ▶ 645] (if the inbound message is linked to more than 1 outbound message)</li> <li><input type="checkbox"/> <i>Outbound message – details</i> screen [ ▶ 653] (if the inbound message is linked to 1 outbound message only)</li> </ul> |
| Inbound File | <p>This function enables you to display the inbound file related to the selected inbound message.</p> <p>Next screen:</p> <ul style="list-style-type: none"> <li><input type="checkbox"/> <i>Inbound file – details</i> screen [ ▶ 625]</li> </ul>   |
| Details      | <p>This function enables you to display the details of the selected inbound message.</p> <p>Next screen:</p> <ul style="list-style-type: none"> <li><input type="checkbox"/> <i>Inbound message – details</i> screen [ ▶ 635]</li> </ul>   |

## 2.4.2.7 Inbound Message - Details Screen

### Context of Usage

This screen displays detailed information on the selected inbound message. You can check the data and proceed further by clicking on the buttons below.

There is no usage restriction for this screen.

This function is only available in U2A mode.

### Screen Access

- Services >> Communication >> Inbound Messages >> *Inbound messages – search/list* screen >> Click on the *search* and/or *details* button
- Services >> Communication >> Outbound Messages >> *Outbound messages – search/list* screen >> Click on the *search* and/or *details* button >> *Outbound message – details* screen >> Click on the *related inbound message* button
- Services >> Communication >> Outbound Messages >> *Outbound messages – search/ list* screen >> Click on the *related inbound message* button
- Cash >> Liquidity >> Immediate Liquidity Transfers >> *Immediate liquidity transfers – search/list* screen >> Click on the *related inbound message* button
- Cash >> Liquidity >> Immediate Liquidity Transfers >> *Immediate liquidity transfers – search/list* screen >> Click on the *search* and/or *details* button >> *Immediate liquidity transfer – details* screen >> Click on the *related inbound message* button

- Cash >> Settlement >> Intra-Balance Movement >> *Intra-balance movements with current and historical status – search* screen >> Click on the *search* button >> *Intra-balance movements - list* screen >> Click on the *details* button >> *Intra-balance movement – details* screen >> Click on the *related inbound message* button
- Cash >> Settlement >> Maintenance Cash Instructions >> *Maintenance cash instructions – search* screen >> Click on the *search* button >> *Maintenance cash instructions - list* screen >> Click on the *details* button >> *Amendment cash instruction - details* screen >> Click on the *related inbound message* button
- Cash >> Settlement >> Maintenance Cash Instructions >> *Maintenance cash instructions – search* screen >> Click on the *search* button >> *Maintenance cash instructions – list* screen >> Click on the *details* button >> *Cancellation cash instruction – details* screen >> Click on the *related inbound message* button
- Services >> Communication >> Inbound Files >> *Inbound files – search/list* screen >> Click on the *search* and/or *details* button >> *Inbound file – details* screen >> Click on the *related inbound message* button
- Securities >> Settlement >> Intra-Position Movements >> *Intra-position movements with current and historical status – search* screen >> Click on the *search* button >> *Intra-position movements - list* screen >> Click on the *details* button >> *Intra-position movement – details* screen >> Click on the *related inbound message* button
- Securities >> Settlement >> Maintenance Securities Instructions >> *Maintenance securities instructions – search* screen >> Click on the *search* button >> *Maintenance securities instructions - list* screen >> Click on the *details* button >> *Amendment securities instruction - details* screen >> Click on the *related inbound message* button
- Securities >> Settlement >> Maintenance Securities Instructions >> *Maintenance securities instructions – search* screen >> Click on the *search* button >> *Maintenance securities instructions – list* screen >> Click on the *details* button >> *Cancellation securities instruction - details* screen >> Click on the *related inbound message* button
- Securities >> Settlement >> Maintenance Securities Instructions >> *Maintenance securities instructions – search* screen >> Click on the *search* button >> *Maintenance securities instructions – list* screen >> Click on the *details* button >> *Hold/release instruction - details* screen >> Click on the *related inbound message* button

- Securities >> Settlement >> Settlement Instructions>> **Settlement Instructions – search** screen >> Click on the **search** button >> **Settlement instructions - list** screen >> Click on **details** button >> **Settlement instruction - details** screen >> Click on the **related inbound messages** button

**Privileges**

To use this screen, you need the following privilege [▶ 884]:

- Inbound message details query

**References**

**User Instructions Part**

This screen is part of the following business scenario:

- View inbound communication [▶ 668]

**Business Functionality Document**

This screen corresponds to the following business function:

- Display message details (T2S.GUI.CCSE.MSG.0030)

**Screenshot**

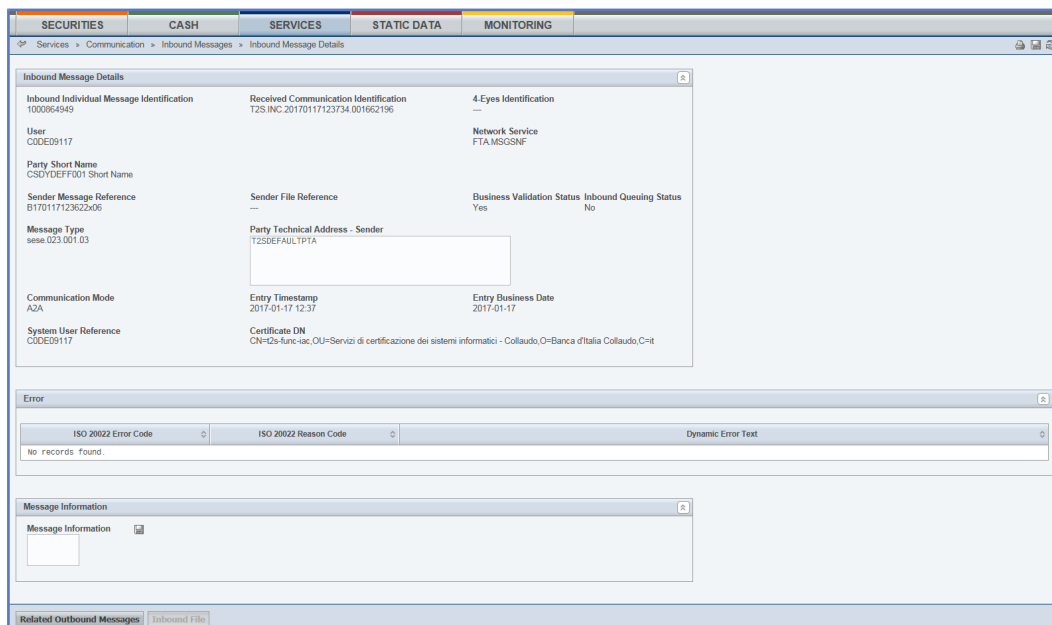

Illustration 124: Inbound message - details screen

**Field Description**

| Inbound Message Details Information |   |
|-------------------------------------|---|
| Entry Date and Time                 | Shows the calendar date and time when the inbound message entered T2S.<br><br>Displayed format is: YYYY-MM-DD hh:mm:ss:µsµsµsµsµs |
| Communication Mode                  | Shows the mode of communication from the possible values:<br><br><input type="checkbox"/> U2A<br><input type="checkbox"/> A2A     |
| Inbound Individual Message          | Shows the identification of the individual message.   |

| Inbound Message Details Information |  |
|-------------------------------------|--|
| Received Communication              | Shows the internal generated identification for the inbound communication.   |
| 4-Eyes Identification               | Shows the identification of the 4-eyes mode which is only used in case of an approval request in 4-eyes mode.  |
| Sender Message Reference            | Shows the identification of the original message sent in the business application header.  |
| Sender File Reference               | Shows the identification of the original file containing the message.  |
| Business Validation Status          | Shows the business validation status from the possible values:<br><input type="checkbox"/> True (business validation successful)<br><input type="checkbox"/> False (business validation finished with error) |
| Inbound Queuing Status              | Shows the inbound queuing status from the possible values:<br><input type="checkbox"/> True (request is currently queued)<br><input type="checkbox"/> False (request is not queued)                          |
| Message Type                        | Shows the message type according to the ISO 20022 standard.  |
| Entry Business Date                 | Shows the business date when T2S received the message.<br>Displayed format is: YYYY-MM-DD  |
| User                                | Shows the user who initiated the communication.  |
| Network Service                     | Shows the name of the network service.   |
| Sending Party Short Name            | Shows the short name of the business sending party.  |
| Party Technical Address - Sender    | Shows the technical address (i.e. distinguished name) of the sender.<br>Displayed format is: max. 256 characters in UTF-8 except '<';>'; '&'   |
| ISO 20022 Error Code                | Shows the error code for the rejection.  |
| Certificate Distinguished Name      | Shows the user information which was extracted from the signature tag in the file header.  |
| System User Reference               | Shows the identification of the system user as extracted from the business application header.   |

| Inbound Message Details Information    |  |
|--|--|
| <b>Repetitive block for each error</b> |  |
| ISO 20022 Error Code                   | Shows the error code for the rejection.  |
| ISO 20022 Reason Code                  | Shows the reason code for the rejection.   |
| Dynamic Error Text                     | Shows a detailed error text explaining why the file was rejected.  |
| <b>Message Information</b>             |  |
| Message Information                    | <p>Shows the detailed information of the U2A or A2A communication.</p> <p>The content of A2A message/U2A request is only displayed in case of small A2A messages/U2A requests. Bigger A2A messages/U2A requests can be displayed via the separate message <i>export</i> icon.</p> <p>Please note that for the U2A request the communication is the representation of the related http request.</p> <p>Pressing this icon exports the message based on the xml document. In addition root elements are present at the beginning and the end of the exported document. On top of the export additional information about 'Time', 'User' and 'T2S Screen of export' is available for documentation purpose.</p> |
| <b>Buttons</b>                         |  |
| Related Outbound Messages              | <p>This function enables you to display the outbound messages related to selected inbound message.</p> <p>Next screens:</p> <ul style="list-style-type: none"> <li><input type="checkbox"/> <i>Outbound messages – search/list</i> screen [ ▶ 645] (if the inbound message is linked to more than 1 outbound message)</li> <li><input type="checkbox"/> <i>Outbound message – details</i> screen [ ▶ 653] (if the inbound message is linked to 1 outbound message only)</li> </ul>   |
| Inbound File                           | <p>This function enables you to display the inbound file related to selected inbound message.</p> <p>Next screen:</p> <ul style="list-style-type: none"> <li><input type="checkbox"/> <i>Inbound file – details</i> screen [ ▶ 625]</li> </ul>   |

## 2.4.2.8 Outbound Files - Search/List Screen

### Context of Usage

This screen contains a number of search fields. By inputting the relevant data, you can search for outbound files. The search result will be displayed in a list, which is sorted by the values of the 'Delivery Date and Time' column descending order (default setting). After selecting an entry, you can proceed further by clicking on the buttons below. Users can see Outbound Files under their datascope.

There is no usage restriction for this screen.

This function is only available in U2A mode.

### Screen Access

Services >> Communication >> Outbound Files

### Privileges

To use this screen you need the following privileges [**▶ 890**]:

- Outbound files list query
- Outbound files details query

### References

#### User Instructions Part

This screen is part of the following business scenario:

- View outbound communication [**▶ 669**]

#### Business Functionality Document

This screen corresponds to the following business functions:

- Query outbound file (T2S.GUI.CCSE.OFL.0010)
- Display outbound file list (T2S.GUI.CCSE.OFL.0020)
- Display outbound file details (T2S.GUI.CCSE.OFL.0030)

### Screenshot

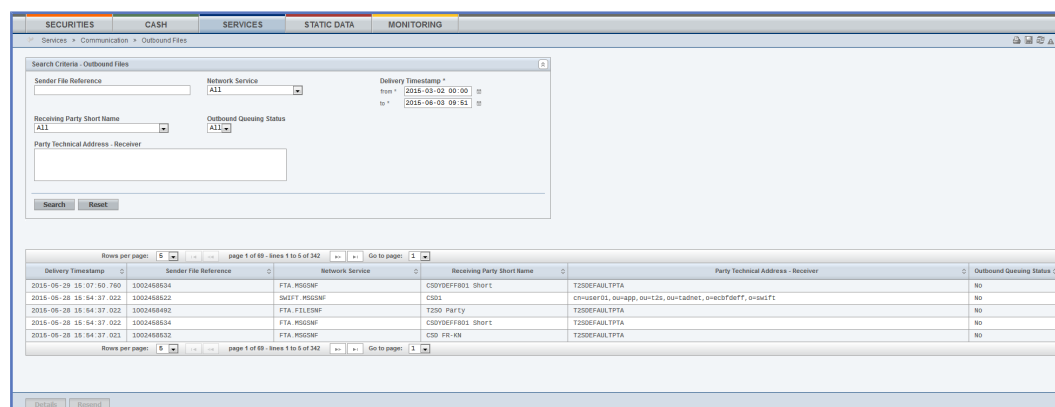

Illustration 125: Outbound files - search/list screen

### Field Description

| Outbound Files – Search Criteria |  |
|----------------------------------|--|
| Sender File Reference            | Enter the sender file identification of the original file containing the message(s).<br>Required format is: max. 16 characters (SWIFT-x) |



| Outbound Files – Search Criteria |  |
|----------------------------------|--|
| Network Service                  | Select the name of the network service from the drop-down menu. The default value is 'All'.  |
| Outbound Communication ID        | Enter the technical ID of the outbound communication.<br>Required format is: Integer   |
| Receiving Party Short Name       | Select the short name of the receiving party from the drop-down menu. The default value is 'All'.  |
| Party Technical Address          | Enter the technical address (i.e. distinguished name) of the party.<br><br>Required format is: max. 256 characters (UTF-8 except '<'; '>'; '&')<br><br>Reference for error message [ ▶ 1043]:<br><input type="checkbox"/> IICR001  |
| Outbound Queuing Status          | Select the outbound queuing status of the file from the possible values:<br><br><input type="checkbox"/> Yes<br><input type="checkbox"/> No<br><input type="checkbox"/> All (default value)  |
| Delivery Date and Time from*     | Enter the lower bound of the search range for the date and time of the delivery or use the <i>calendar</i> icon. The default value is the current date – start of real-time settlement.<br><br>Required format is: YYYY-MM-DD hh:mm:ss<br><br>The 'Delivery Date and Time from' date must be earlier than or equal to the current business date and earlier than the 'Delivery Date and Time to' date.<br><br>References for error messages [ ▶ 1043]:<br><input type="checkbox"/> QMPC015<br><input type="checkbox"/> QMPC073 |
| Delivery Date and Time to*       | Enter the upper bound of the search range for the date and time of the delivery or use the <i>calendar</i> icon. The default value is the current date and time.<br><br>Required format is: YYYY-MM-DD hh:mm:ss<br><br>The 'Delivery Date and Time to' date must be later than the 'Delivery Date and Time from' date.<br><br>Reference for error message [ ▶ 1043]:<br><input type="checkbox"/> QMPC015   |

| Outbound Files – Search Criteria   |  |
|--|--|
| Outbound Files – List<br>Repetitive block for each business object of an outbound file |  |
| Delivery Date and Time   | Shows the date and time when the outbound file was delivered.<br><br>Displayed format is: YYYY-MM-DD hh:mm:ss:µsµsµsµsµsµs                       |
| Sender File Reference  | Shows the sender file identification of the original file containing the message(s).   |
| Outbound Communication ID  | Shows the technical ID of the outbound communication.  |
| Network Service  | Shows the name of the network service.   |
| Receiving Party Short Name   | Shows the short name of the receiving party.   |
| Party Technical Address  | Shows the technical address (i.e. distinguished name) of the party.<br><br>Displayed format is: max. 256 characters (UTF-8 except '<'; '>'; '&') |
| Outbound Queuing Status  | Shows the outbound queuing status of the file from the possible values:<br><br><input type="checkbox"/> Yes<br><input type="checkbox"/> No       |

## Buttons

| Search | This function enables you to start a search according to the criteria entered. The results are displayed in a list on the same screen.<br><br>If the search retrieves a single record, the <i>details</i> screen is displayed directly.<br><br>Next screens:<br><input type="checkbox"/> <i>Outbound files – search/list</i> screen<br><input type="checkbox"/> <i>Outbound file – details</i> screen [ ▶ 643]<br><br>References for error messages [ ▶ 1043]:<br><input type="checkbox"/> QMPC015<br><input type="checkbox"/> QMPC073 |
|--------|--|

|         |   |
|---------|---|
| Reset   | This function enables you to set default search criteria and blanks out all optional criteria.<br>Next screen:<br><input type="checkbox"/> <i>Outbound files – search/list</i> screen |
| Details | This function enables you to display the details of the selected outbound file.<br>Next screen:<br><input type="checkbox"/> <i>Outbound file – details</i> screen [▶ 643]             |

## 2.4.2.9 Outbound File - Details Screen

### Context of Usage

This screen displays detailed information on the selected outbound file. You can check the data and proceed further by clicking on the buttons below.

There is no usage restriction for this screen.

This function is only available in U2A.

### Screen Access

- Services >> Communication >> Outbound Files >> *Outbound files – search/list* screen >> Click on the *search* and/or *details* button
- Services >> Communication >> Outbound Messages >> *Outbound messages – search/list* screen >> Click on the *outbound file* button
- Services >> Communication >> Outbound Messages >> *Outbound messages – search/list* screen >> Click on the *search* and/or *details* button >> *Outbound message – details* screen >> Click on the *outbound file* button

### Privileges

To use this screen you need the following privileges [▶ 890]:

- Outbound files details query
- Resend Communication

### References

#### User Instructions Part

This screen is part of the following business scenario:

- View outbound communication [▶ 669]

#### Business Functionality Document

This screen corresponds to the following business functions:

- Display message details (T2S.GUI.CCSE.MSG.0030)
- Display outbound file details (T2S.GUI.CCSE.OFL.0030)

Screenshot

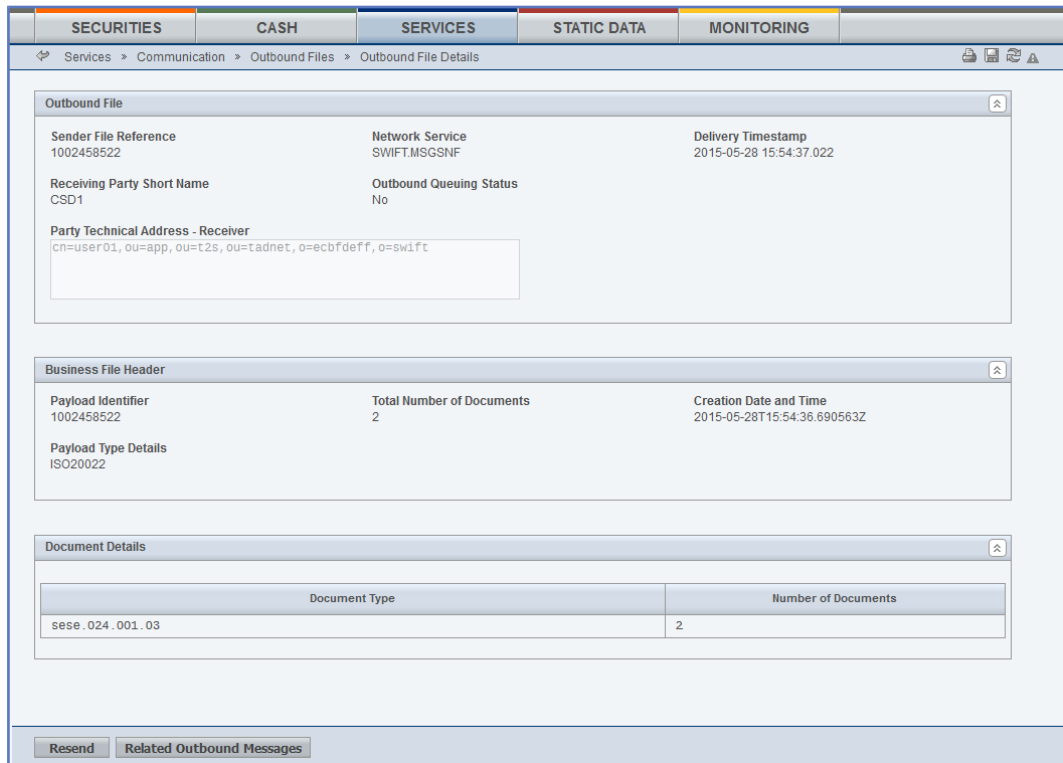

Illustration 126: Outbound file - details screen

Field Description

| Outbound Files Details Information |   |
|------------------------------------|---|
| Delivery Date and Time             | Shows date and time when the file was delivered.<br>Displayed format is: YYYY-MM-DD hh:mm:ss:µsµsµsµsµs   |
| Sender File Reference              | Shows the sender file identification of the original file containing the message(s).  |
| Network Service                    | Shows the name of the network service.  |
| Receiving Party Short Name         | Shows the short name of the receiving party.  |
| Party Technical Address            | Shows the technical address of a party.<br>Reference for error message [▶ 1043]:<br><input type="checkbox"/> IICR001                            |
| Outbound Queuing Status            | Shows the outbound queuing status of the outbound file from the possible values:<br><input type="checkbox"/> Yes<br><input type="checkbox"/> No |
| Business File Header               |   |
| Payload Details                    |   |
| Payload Identifier                 | Shows the unique identification of the file delivered by the sender.  |

| Outbound Files Details Information                            |   |
|---|---|
| Creation Date and Time  | Shows the date and time of the creation of the file.<br>Displayed format is: YYYY-MM-DD hh:mm:ss:µsµsµsµsµs |
| Total Number of Documents                                     | Shows the total number of documents within the file.  |
| Payload Type Details  | Shows information about the type of payload and declaration of the payload content.                         |
| Document Details  |   |
| Repetitive block for each business object of an outbound file |   |
| Document Type   | Shows the type of items contained in the document set.  |
| Number of Documents   | Shows the number of messages for each declared type.  |

### Buttons

|                           |  |
|---------------------------|--|
| Related Outbound Messages | <p>This function enables you to display the outbound messages related to the selected outbound file.</p> <p>Next screens:</p> <ul style="list-style-type: none"> <li><input type="checkbox"/> <i>Outbound messages – search/list</i> screen [ ▶ 645] (if the outbound file is linked to more than one outbound message)</li> <li><input type="checkbox"/> <i>Outbound message – details</i> screen [ ▶ 653] (if the outbound file is linked to one outbound message only)</li> </ul> |
| Resend                    | <p>This function enables you to resend the selected outbound file.</p> <p>Next screen:</p> <ul style="list-style-type: none"> <li><input type="checkbox"/> <i>Outbound file – details</i> screen</li> </ul> <p>References for error messages [ ▶ 1043]:</p> <ul style="list-style-type: none"> <li><input type="checkbox"/> IICR001</li> <li><input type="checkbox"/> IICR002</li> </ul>   |

## 2.4.2.10 Outbound Messages - Search/List Screen

### Context of Usage

This screen contains a number of search fields. By inputting the relevant data, you can search for subscribed outbound messages and those sent compulsory. The search result will be displayed in a list, which is sorted by the values of the 'Delivery Date and Time' column in descending order (default setting). Only mes-

sages subscribed via message subscription rules and those messages compulsory sent will be displayed. After selecting an entry, you can proceed further by clicking on the buttons below.

This screen shows all outbound messages irrespective of whether they were sent via file or as single message. Users can see Outbound Messages under their datascope.

There is no usage restriction for this screen.

This function is only available in U2A mode.

## Screen Access

- Services >> Communication >> Outbound Messages
- Services >> Communication >> Inbound Messages >> *Inbound messages – search/list* screen >> Click on the *related outbound messages* button
- Services >> Communication >> Inbound Messages >> *Inbound messages – search/list* screen >> Click on the *search* and/or *details* button >> *Inbound message - details* screen >> Click on the *related outbound messages* button
- Services >> Communication >> Outbound Files >> *Outbound files – search/list* screen >> Click on the *search* and/or *details* button >> *Outbound file - details* screen >> Click on the *related outbound messages* button
- Cash >> Liquidity >> Immediate Liquidity Transfers >> *Immediate liquidity transfers - search/list* screen >> Click on the *related outbound messages* button
- Cash >> Liquidity >> Immediate Liquidity Transfers >> *Immediate liquidity transfers – search/list* screen >> Click on the *search* and/or *details* button >> *Immediate liquidity transfers – details* screen >> Click on the *related outbound messages* button
- Cash >> Settlement >> Intra-Balance Movements >> *Intra-balance movements – search/list* screen >> Click on the *search* button >> *Intra-balance movements – search/list* screen >> Click on the *details* button >> *Intra-balance movement - details* screen >> Click on the *related outbound messages* button
- Cash >> Settlement >> Maintenance Cash Instructions >> *Maintenance cash instructions – search/list* screen >> Click on the *search* button >> *Maintenance cash instructions – search/list* screen >> Click on the *details* button >> *Amendment cash instruction - details* screen >> Click on the *related outbound message* button

- Securities >> Settlement >> Maintenance Securities Instructions >> *Maintenance securities instructions – search/list* screen >> Click on the *search* button >> *Maintenance securities instructions – search/list* screen >> Click on the *details* button >> *Amendment securities instruction - details* screen >> Click on the *related outbound message* button
- Securities >> Settlement >> Intra-Position Movements >> *Intra-position movements – search/list* screen >> Click on the *search* button >> *Intra-position movements – search/list* screen >> Click on the *details* button >> *Intra –position movement - details* screen >> Click on the *related outbound messages* button
- Cash >> Settlement >> Maintenance Cash Instructions >> *Maintenance cash instructions – search/list* screen >> Click on the *search* button >> *Maintenance cash instructions – search/list* screen >> Click on the *details* button >> *Cancellation cash instruction – details* screen >> Click on the *related outbound message* button
- Securities >> Settlement >> Maintenance Securities Instructions >> *Maintenance securities instructions – search/list* screen >> Click on the *search* button >> *Maintenance securities instructions – search/list* screen >> Click on the *details* button >> *Cancellation securities instruction - details* screen >> Click on the *related outbound message* button
- Securities >> Settlement >> Maintenance Securities Instructions >> *Maintenance securities instructions – search/list* screen >> Click on the *search* button >> *Maintenance securities instructions – search/list* screen >> Click on the *details* button >> *Hold/release instruction - details* screen >> Click on the *related outbound message* button
- Securities >> Settlement >> Settlement Instructions >> *Settlement Instructions – search/list* screen >> Click on the *search* button >> *Settlement instructions – search/list* screen >> Click on the *details* button >> *Settlement instruction - details* screen >> Click on the *related outbound messages* button

**Privileges**

To use this screen, you need the following privileges [▶ 891]:

- Outbound message list query
- Outbound message details query
- Resend Communication

**References****User Instructions Part**

This screen is part of the following business scenario:

- View outbound communication [▶ 669]

### Business Functionality Document

This screen corresponds to the following business functions:

- Query messages (T2S.GUI.CCSE.MSG.0010)
- Display message list (T2S.GUI.CCSE.MSG.0020)

### Screenshot

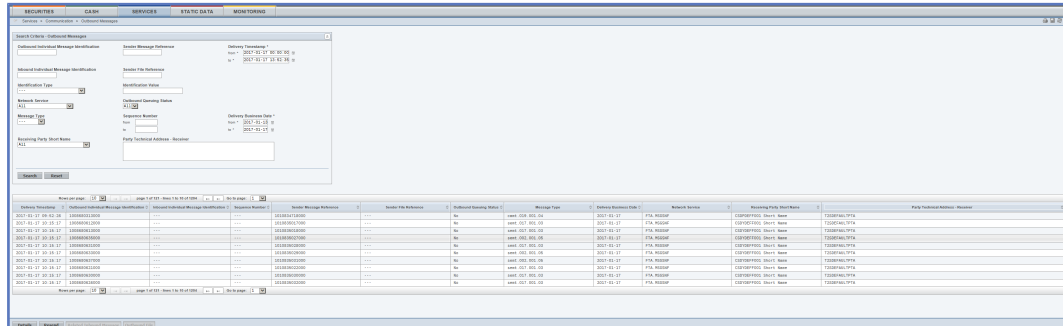

Illustration 127: Outbound messages - search/list Screen

### Field Description

| Outbound Messages – Search Criteria        |   |
|--|---|
| Outbound Individual Message Identification | Enter the technical identification of the outbound individual message.<br>Required format is: Integer   |
| Inbound Individual Message Identification  | Enter the technical identification of the inbound individual message.<br>Required format is: Integer  |
| Network Service                            | Select the name of the network service from the drop-down menu. The default value is 'All'.   |
| Receiving Party Short Name                 | Select the short name of the receiving party from the drop-down-menu. The default value is 'All'.   |
| Party Technical Address                    | Enter the technical address (i.e. distinguished name) of the receiving party.<br>Required format is: max. 256 characters (UTF-8 except '<'; '>'; '&')<br>Reference for error message [ ▶ 1045]:<br><input type="checkbox"/> IICR001 |
| Message Type                               | Select the request type (ISO 20022) for the message from the drop-down menu. The default value is 'All'.  |
| Sender Message Reference                   | Enter the identification of the message as assigned by the message sender.<br>Required format is: max. 16 characters (SWIFT-x)  |
| Sender File Reference                      | Enter the sender file identification of the file containing the message(s).   |



| Outbound Messages – Search Criteria |   |
|-------------------------------------|---|
|                                     | Required format is: max. 16 characters (SWIFT-x)  |
| Identification Type                 | <p>Select the type of identification of the message from the possible values:</p> <ul style="list-style-type: none"> <li><input type="checkbox"/> T2S Instruction Reference</li> <li><input type="checkbox"/> Transfer Identification (for Liquidity Transfers)</li> <li><input type="checkbox"/> Blank (for non-usage of the search criterion and used as default value)</li> </ul> <p>The Identification Type must be either 'T2S Instruction Reference' or 'Transfer Identification' if the Instruction Value is filled.</p> <p>The Identification Type must be blank if the Identification Value is blank.</p>  |
| Identification Value                | <p>Enter the unique identification of the Instruction and Liquidity Transfer if instruction type is not blank.</p> <p>The Identification Value must be filled if the Instruction Type is filled with 'T2S Instruction Reference' or 'Transfer Identification'.</p> <p>The Identification Value must not be filled if the Instruction Type is filled with 'blank'.</p>   |
| Outbound Queuing Status*            | <p>Select the outbound queuing status of the message from the possible values:</p> <ul style="list-style-type: none"> <li><input type="checkbox"/> Yes</li> <li><input type="checkbox"/> No</li> <li><input type="checkbox"/> All (default value)</li> </ul>  |
| Delivery Date and Time from(*)      | <p>Enter the lower bound of the search range for the calendar date and time of the system entry of the outbound message or use the <i>calendar</i> icon. The default value is the current date – start of real-time settlement if the 'Inbound Individual Message Identification' / 'T2S Instruction Reference' / 'Transfer Identification' / 'Sender File Reference' is not populated from the previous screen.</p> <p>Required format is: YYYY-MM-DD hh:mm:ss</p> <p>The 'Delivery Date and Time from' date must be a valid calendar date/time and earlier than or equal to the current T2S date. The 'Delivery Date and Time from' date must be earlier than the 'Delivery Date and Time to' date.</p> |

| Outbound Messages – Search Criteria |  |
|-------------------------------------|--|
|                                     | <p>Reference for error message [ ▶ 1045]:</p> <p><input type="checkbox"/> QMPC015</p>  |
| Delivery Date and Time to(*)        | <p>Enter the upper bound of the search range for the calendar date and time of the system entry of the outbound message or use the <i>calendar</i> icon. The default value is the current date and time if the 'Inbound Individual Message Identification' / 'T2S Instruction Reference' / 'Transfer Identification' / 'Sender File Reference' is not populated from the previous screen.</p> <p>Required format is: YYYY-MM-DD hh:mm:ss</p> <p>The 'Delivery Date and Time to' date must be later than the 'Delivery Date and Time from' date and a valid T2S calendar date/time.</p> <p>Reference for error message [ ▶ 1045]:</p> <p><input type="checkbox"/> QMPC015</p> |
| Delivery Business Date from(*)      | <p>Enter the lower bound of the search range for the business date from which the outbound message was delivered or use the <i>calendar</i> icon. The default value is the current business date if the 'Inbound Individual Message Identification' / 'T2S Instruction Reference' / 'Transfer Identification' / 'Sender File Reference' is not populated from the previous screen.</p> <p>Required format is: YYYY-MM-DD</p> <p>The 'Delivery Business Date from' date must be a valid T2S calendar date earlier than or equal to the current T2S calendar date.</p> <p>Reference for error message [ ▶ 1045]:</p> <p><input type="checkbox"/> QMPC015</p>                   |
| Delivery Business Date to(*)        | <p>Enter the upper bound of the search range for the date until which the outbound message was delivered or use the <i>calendar</i> icon. The default value is the current business date if the 'Inbound Individual Message Identification' / 'T2S Instruction Reference' / 'Transfer Identification' / 'Sender File Reference' is not populated from the previous screen.</p> <p>Required format is: YYYY-MM-DD</p>   |

| Outbound Messages – Search Criteria                              |   |
|--|---|
|  | <p>The 'Delivery Business Date to' date must be a valid T2S business date.</p> <p>Reference for error message [ ▶ 1045]:</p> <ul style="list-style-type: none"> <li><input type="checkbox"/> QMPC015</li> </ul> |
| Outbound Messages – List   |   |
| Repetitive block for each business object of an outbound message |   |
| Delivery Date and Time   | <p>Shows the date and time when the message was delivered in T2S.</p> <p>Displayed format is: YYYY-MM-DD hh:mm:ss:µsµsµsµsµs</p>  |
| Outbound Individual Message Identification                       | Shows the identification of the outbound individual message.  |
| Inbound Individual Message Identification                        | Shows the identification of the inbound individual message.   |
| Outbound Message Sequence Number                                 | Shows the counter for the external message sequence which is available once per party technical address.  |
| Sender Message Reference   | Shows the identification of the outbound message as assigned by the message sender.   |
| Sender File Reference  | Shows the identification of the original file containing the message(s).  |
| Outbound Queuing Status  | <p>Shows the outbound queuing status of the message from the possible values:</p> <ul style="list-style-type: none"> <li><input type="checkbox"/> Yes</li> <li><input type="checkbox"/> No</li> </ul>           |
| Message Type   | Shows the ISO 20022 request type of the message.  |
| Delivery Business Date   | <p>Shows the business date when T2S started the delivery of the message.</p> <p>Displayed format is: YYYY-MM-DD</p>   |
| Network Service  | Shows the name of the network service.  |
| Receiving Party Short Name                                       | Shows the short name of the receiving party.  |
| Party Technical Address  | Shows the technical address (i.e. distinguished name) of the receiving party.   |

| Outbound Messages – Search Criteria |  |
|-------------------------------------|--|
|                                     | <p>Displayed format: max. 256 characters (UTF-8 except '&lt;'; '&gt;'; '&amp;')</p> <p>Reference for error message [ ▶ 1045]:</p> <ul style="list-style-type: none"> <li><input type="checkbox"/> IICR001</li> </ul> |

**Buttons**

| Search                   | <p>This function enables you to start a search according to the criteria entered. The results are displayed in a list on the same screen.</p> <p>If the search retrieves a single record, the <i>details</i> screen is displayed directly.</p> <p>Next screens:</p> <ul style="list-style-type: none"> <li><input type="checkbox"/> <i>Outbound messages – search/list</i> screen</li> <li><input type="checkbox"/> <i>Outbound message – details</i> screen [ ▶ 653]</li> </ul> <p>Reference for error message [ ▶ 1045]:</p> <ul style="list-style-type: none"> <li><input type="checkbox"/> QMPC015</li> </ul> |
|--------------------------|---|
| Reset                    | <p>This function enables you to set default search criteria and blanks out all optional criteria.</p> <p>Next screen:</p> <ul style="list-style-type: none"> <li><input type="checkbox"/> <i>Outbound messages – search/list</i> screen</li> </ul>  |
| Outbound File            | <p>This function enables you to display the details of the related outbound file.</p> <p>Next screen:</p> <ul style="list-style-type: none"> <li><input type="checkbox"/> <i>Outbound file – details</i> screen [ ▶ 643]</li> </ul>   |
| Related Inbound Messages | <p>This function enables you to display the inbound messages related to the selected outbound message.</p> <p>Next screen:</p> <ul style="list-style-type: none"> <li><input type="checkbox"/> <i>Inbound message – details</i> screen [ ▶ 635]</li> </ul>  |
| Resend                   | <p>This function enables you to resend the selected outbound message.</p> <p>Next screen:</p> <ul style="list-style-type: none"> <li><input type="checkbox"/> <i>Outbound messages – search/list</i> screen</li> </ul> <p>References for error messages [ ▶ 1045]:</p> <ul style="list-style-type: none"> <li><input type="checkbox"/> IICR001</li> <li><input type="checkbox"/> IICR002</li> </ul>   |

|         |  |
|---------|--|
| Details | This function enables you to display the details of the selected outbound message.<br>Next screen:<br><input type="checkbox"/> <i>Outbound message – details</i> screen [ 653] |
|---------|--|

## 2.4.2.11 Outbound Message - Details Screen

### Context of Usage

This screen displays detailed information on the selected outbound message. Only messages subscribed via message subscription rules and those messages compulsory sent will be displayed. You can check the data and proceed further by clicking on the buttons below.

There is no usage restriction for this screen.

This function is only available in U2A mode.

### Screen Access

- Services >> Communication >> Outbound Messages >> *Outbound messages – search/list* screen >> Click on the *search* and/or *details* button
- Services >> Communication >> Inbound Messages >> *Inbound messages – search/list* screen >> Click on the *related outbound messages* button
- Services >> Communication >> Inbound Messages >> *Inbound messages – search/list* screen >> Click on the *search* and/or *details* button >> *Inbound message – details* screen >> Click on the *related outbound messages* button
- Services >> Communication >> Outbound Files >> *Outbound files – search/list* screen >> Click on the *search* and/or *details* button >> *Outbound file – details* screen >> Click on the *related outbound messages* button
- Cash >> Liquidity >> Immediate Liquidity Transfers >> *Immediate liquidity transfers - search/list* screen >> Click on the *related outbound messages* button
- Cash >> Liquidity >> Immediate Liquidity Transfers >> *Immediate liquidity transfers - search/list* screen >> Click on the *search* and/or *details* button >> *Immediate liquidity transfer – details* screen >> Click on the *related outbound messages* button
- Cash >> Settlement >> Intra-Balance Movements >> *Intra-balance movements – search/list* screen >> Click on the *search* button >> *Intra-balance movements – search/list* screen >> Click on the *details* button >> *Intra-balance movement - details* screen >> Click on the *related outbound messages* button

- Securities >> Settlement >> Intra-Position Movements >> *Intra-position movements – search/list* screen >> Click on the *search* button >> *Intra-position movements – search/list* screen >> Click on the *details* button >> *Intra-position movement - details* screen >> Click on the *related outbound messages* button
- Cash >> Settlement >> Maintenance Cash Instructions >> *Maintenance cash instructions – search/list* screen >> Click on the *search* button >> *Maintenance cash instructions – search/list* screen >> Click on the *details* button >> *Amendment cash instruction - details* screen >> Click on the *related outbound message* button
- Securities >> Settlement >> Maintenance Securities Instructions >> *Maintenance securities instructions – search/list* screen >> Click on the *search* button >> *Maintenance securities instructions – search/list* screen >> Click on the *details* button >> *Amendment securities instruction - details* screen >> Click on the *related outbound message* button
- Cash >> Settlement >> Maintenance Cash Instructions >> *Maintenance cash instructions – search/list* screen >> Click on the *search* button >> *Maintenance cash instructions – search/list* screen >> Click on the *details* button >> *Cancellation cash instruction – details* screen >> Click on the *related outbound message* button
- Securities >> Settlement >> Maintenance Securities Instructions >> *Maintenance securities instructions – search/list* screen >> Click on the *search* button >> *Maintenance securities instructions – search/list* screen >> Click on the *details* button >> *Cancellation securities instruction - details* screen >> Click on the *related outbound message* button
- Securities >> Settlement >> Maintenance Securities Instructions >> *Maintenance securities instructions – search/list* screen >> Click on the *search* button >> *Maintenance securities instructions – search/list* screen >> Click on the *details* button >> *Hold/release instruction - details* screen >> Click on the *related outbound message* button
- Securities >> Settlement >> Settlement Instructions >> *Settlement instructions – search/list* screen >> Click on the *search* button >> *Settlement instructions – search/list* screen >> Click on *details* button >> *Settlement instruction - details* screen >> Click on the *related outbound messages* button

**Privileges**

To use this screen, you need the following privileges [► 891]:

- Outbound message details query
- Resend Communication

**References**

**User Instructions Part**

This screen is part of the following business scenario:

- View outbound communication [▶ 669]

**Business Functionality Document**

This screen corresponds to the following business functions:

- Display message details (T2S.GUI.CCSE.MSG.0030)

**Screenshot**

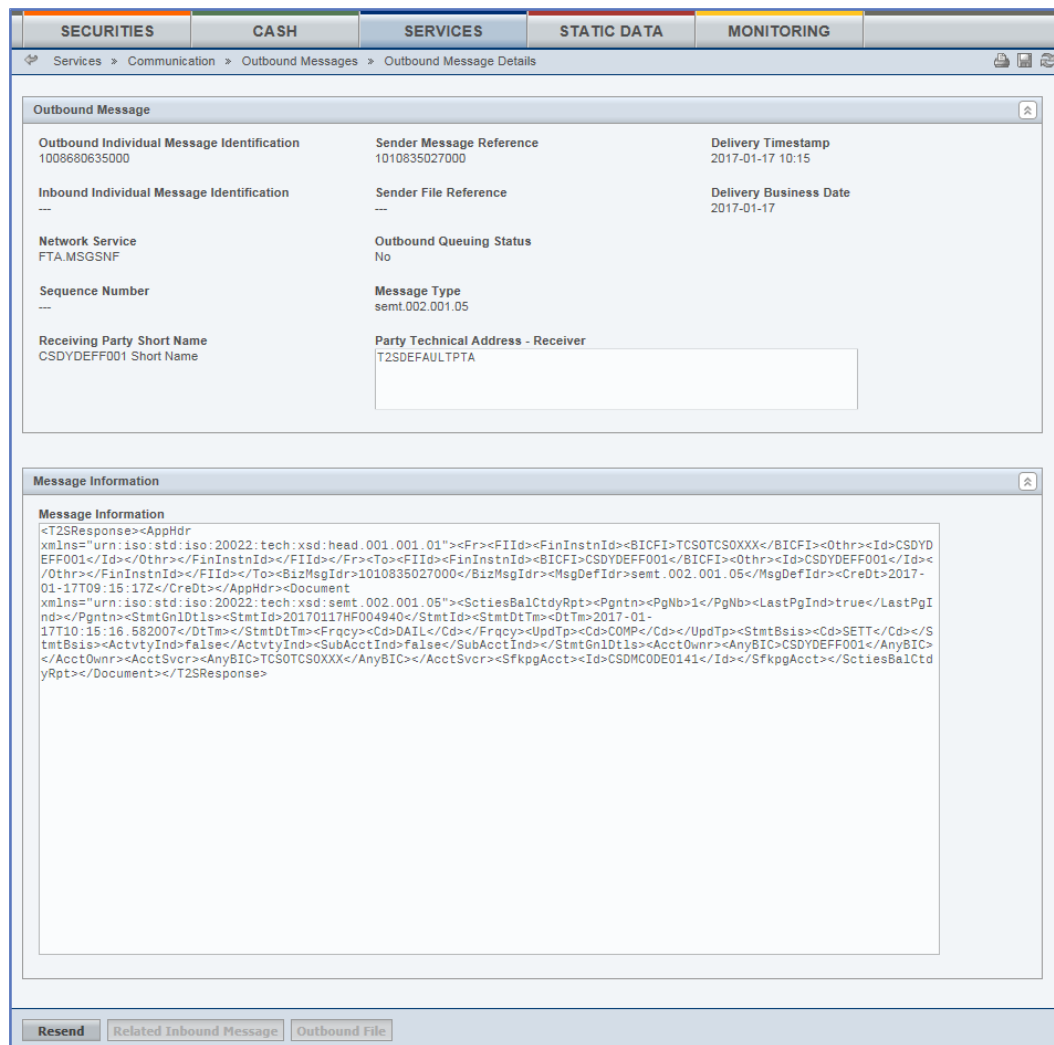

Illustration 128: Outbound message - details screen

**Field Description**

| Outbound Message Details Information       |   |
|--|---|
| Delivery Date and Time                     | Shows the calendar date and time when the outbound message was delivered in T2S.<br><br>Displayed format is: YYYY-MM-DD hh:mm:ss:µsµsµsµsµsµs |
| Outbound Individual Message Identification | Shows the identification of the outbound individual message.  |

| Outbound Message Details Information      |   |
|---|---|
| Inbound Individual Message Identification | Shows the identification of the inbound individual message.   |
| Outbound Message Sequence Number          | Shows the counter for the external message sequence which is available once per party technical address.  |
| Sender Message Reference                  | Shows the identification of the outbound message as assigned by the message sender.   |
| Sender File Reference                     | Shows the identification of the original file containing the message(s).  |
| Outbound Queuing Status                   | Shows the outbound queuing status of the message from the possible values:<br><br><input type="checkbox"/> Yes<br><input type="checkbox"/> No   |
| Message Type                              | Shows the ISO 20022 request type of the message.  |
| Delivery Business Date                    | Shows the business date when T2S started the delivery of the message.<br><br>Displayed format is: YYYY-MM-DD  |
| Network Service                           | Shows the name of the network service.  |
| Receiving Party Short Name                | Shows the short name of the receiving party.  |
| Party Technical Address                   | Shows the technical address (i.e. distinguished name) of the receiving party.<br><br>Reference for error message [ ▶ 1044]:<br><br><input type="checkbox"/> IICR001   |
| Message Information                       |   |
| Message Information                       | Shows detailed information of the U2A or A2A request.<br><br>The content of A2A message/U2A request is only displayed in case of small A2A messages/U2A requests. Bigger A2A messages/U2A requests can be displayed via the separate message <i>export</i> icon. Pressing this icon exports the message based on the xml document. In addition root elements are present at the beginning and the end of the exported document. On top of the export additional information about 'Time', 'User' and 'T2S Screen of export' is available for documentation purpose. |



**Buttons**

|                          |  |
|--------------------------|--|
| Related Inbound Messages | This function enables you to display the inbound messages related to the selected outbound message.<br>Next screen:<br><input type="checkbox"/> <i>Inbound message – details</i> screen [▶ 635]  |
| Resend                   | This function enables you to resend the selected outbound message.<br>Next screen:<br><input type="checkbox"/> <i>Outbound message – details</i> screen<br>References for error messages [▶ 1044]:<br><input type="checkbox"/> IICR001<br><input type="checkbox"/> IICR002 |
| Outbound File            | This function enables you to display the outbound file related to the selected outbound message.<br>Next screen:<br><input type="checkbox"/> <i>Outbound file – details</i> screen [▶ 643]   |

## 2.4.2.12 Resend Communication Screen

**Context of Usage**

This screen contains a number of fields regarding resend communication. You may select already sent outbound messages by entering:

- a single sequence,
- a range of sequences with explicitly mentioned values for
  - 'Sequence – from' and 'Sequence – to' or
  - 'Sequence – from' and open end or
  - 'Sequence – to' and open start
- a combination of a range of sequences and an additional single sequence
- a T2S sender message reference.

You may also resend outbound files by entering a sender file reference. Afterwards you can proceed further by clicking on the buttons below.

You can use this screen either in 2-eyes or in 4-eyes mode.

There is no usage restriction for this screen.

**Screen Access**

- Services >> Communication >> Resend Communication

**Privileges**

To use this screen, you need the following privilege [▶ 894]:

- Resend communication

**References**

**User Instructions Part**

This screen is part of the following business scenario:

- Resend communication [▶ 667]

**Business Functionality Document**

This screen corresponds to the following business function:

- Request outbound message resend (T2S.GUI.CCSE.MSG.0040)

**Screenshot**

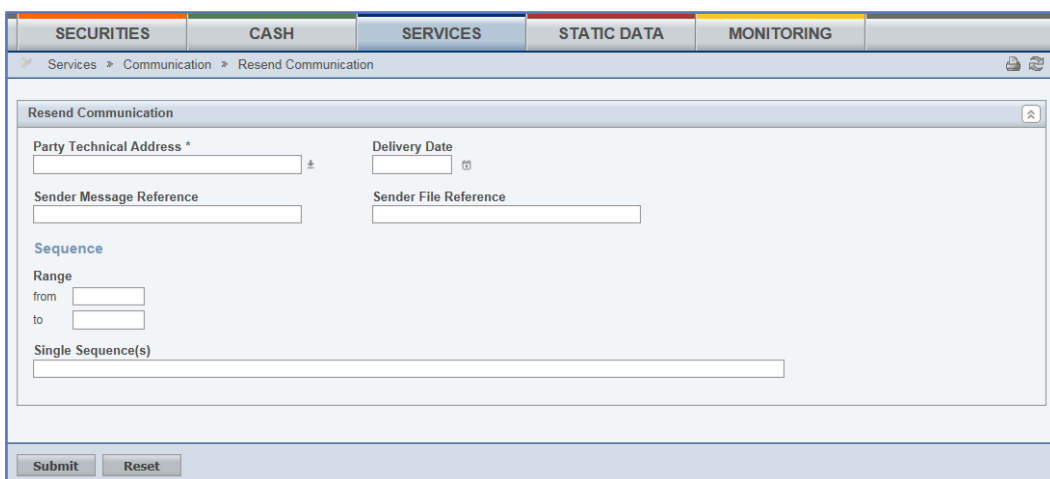

Illustration 129: Resend communication screen

**Field Description**

| Resend Communication     |   |
|--------------------------|---|
| Party Technical Address* | <p>You can choose to either enter the 'Party Technical Address' or to select it from the suggested items in the dropdown menu.</p> <p>Required format is: max. 256 characters (SWIFT-x)</p> <p>References for error messages [▶ 1051]:</p> <ul style="list-style-type: none"> <li><input type="checkbox"/> IICR001</li> <li><input type="checkbox"/> IICR004</li> <li><input type="checkbox"/> IICR006</li> <li><input type="checkbox"/> IICR007</li> </ul> |
| Delivery Date            | <p>Enter the date of the business day on which the outbound message was sent or use the <i>calendar</i> icon.</p> <p>Required format is: YYYY-MM-DD</p> <p>References for error messages [▶ 1051]:</p> <ul style="list-style-type: none"> <li><input type="checkbox"/> IICR003</li> <li><input type="checkbox"/> IICR004</li> <li><input type="checkbox"/> IICR006</li> </ul>   |

| Resend Communication     |   |
|--------------------------|---|
|                          | <input type="checkbox"/> IICR007<br>If you do not select a date, this field is filled in with the current business date.  |
| Sender Message Reference | Enter the identification of the original message as sent in the business application header.<br><br>Required format is: max. 16 characters (SWIFT-x)<br>Reference for error message [ ▶ 1051]:<br><br><input type="checkbox"/> IICR007<br><br>You have to enter at least one field among 'Sender Message Reference', 'Sender File Reference', 'Sequence – from', 'Sequence – to' and 'Single Sequence(s)'.  |
| Sender File Reference    | Enter the identification of the original file as sent in the business application header.<br><br>Required format is: max. 16 characters (SWIFT-x)<br>Reference for error message [ ▶ 1051]:<br><br><input type="checkbox"/> IICR006<br><br>You have to enter at least one field among 'Sender Message Reference', 'Sender File Reference', 'Sequence – from', 'Sequence – to' and 'Single Sequence(s)'.   |
| Sequence                 |   |
| Sequence - from          | Enter the lower bound of the specific outbound sequence reference.<br><br>Required format is: max. 8 digits<br><br>The 'Sequence – from' range must be lower than or equal to the 'Sequence – to' range.<br><br>You have to enter at least one field among 'Sender Message Reference', 'Sender File Reference', 'Sequence – from', 'Sequence – to' and 'Single Sequence(s)'.<br><br>Remark: To submit a resend of messages the sequence number has to be filled with up to 8 digits, without business date prefix. Leading zeros can be omitted. Business date is taken from the separate field. In case the business date field is not filled the current business date is used. |
| Sequence - to            | Enter the upper bound of the specific outbound sequence reference.  |

| Resend Communication |   |
|----------------------|---|
|                      | <p>Required format is: max. 8 digits</p> <p>The 'Sequence – to' range must be higher than or equal to the 'Sequence – from' range.</p> <p>You have to enter at least one field among 'Sender Message Reference', 'Sender File Reference', 'Sequence – from', 'Sequence – to' and 'Single Sequence(s)'.</p> <p>Remark: To submit a resend of messages the sequence number has to be filled with up to 8 digits, without business date prefix. Leading zeros can be omitted. Business date is taken from the separate field. In case the business date field is not filled the current business date is used.</p> |
| Single Sequence(s)   | <p>Enter the outbound sequence identification you want to resend.</p> <p>Required format is: max. 169 characters (SWIFT-x)</p> <p>Reference for error message [ ▶ 1051]:</p> <ul style="list-style-type: none"> <li><input type="checkbox"/> IICR004</li> </ul> <p>You have to enter at least one field among 'Sender Message Reference', 'Sender File Reference', 'Sequence – from', 'Sequence – to' and 'Single Sequence(s)'.</p>   |

**Buttons**

| Submit | <p>This function enables you to create a resend message request based on the selection you made, after confirmation.</p> <p>Next screen:</p> <ul style="list-style-type: none"> <li><input type="checkbox"/> <i>Resend communication</i> screen</li> </ul> <p>References for error messages [ ▶ 1051]:</p> <ul style="list-style-type: none"> <li><input type="checkbox"/> IICR001</li> <li><input type="checkbox"/> IICR002</li> <li><input type="checkbox"/> IICR003</li> <li><input type="checkbox"/> IICR004</li> <li><input type="checkbox"/> IICR006</li> <li><input type="checkbox"/> IICR007</li> </ul> |
|--------|---|
| Reset  | <p>This function enables you to set all fields to default value and blanks out all optional fields.</p> <p>Next screen:</p>   |

- Resend communication screen

## 2.4.3 Revisions

### 2.4.3.1 Revisions/Audit Trail - List Screen

#### Context of Usage

This screen shows search results for revisions for the selected transactional objects in a list and is not present in T2S menu. After selecting an entry, you can proceed further by clicking on the button below.

When exporting the content of this screen, you receive the list and the corresponding details for each data record.

The screen can be reached via any other *list* or *details* screen by clicking on the *revisions* button.

#### Screen Access

- Screen name >> Click on the *revisions* button

#### Privileges

To use this screen, you need (depending on the underlying object) the following privileges [[▶ 895](#)]:

- Amendment instruction for intra-position movement or settlement instruction audit trail list query
- Amendment instruction for intra-balance movement audit trail list query
- Cancellation instruction for intra-balance movement audit trail list query
- Cancellation instruction for intra-position movement or settlement instruction audit trail list query
- Intra-balance movement audit trail list query
- Intra-position movement audit trail list query
- Immediate liquidity transfer order audit trail list query
- Penalty audit trail query
- Settlement instruction audit trail query

#### References

##### User Instructions Part

This screen is part of the following business scenario:

- View revisions [[▶ 1052](#)]

##### Business Functionality Document

This screen corresponds to the following business function:

- Display revision list (T2S.GUI.OSSE.REV.0010)

**Screenshot**

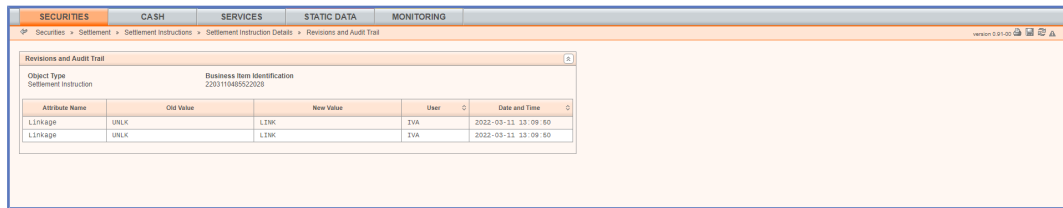

Illustration 130: Revisions/audit trail – list screen

**Field**

**Description**

| Revisions – List               |  |
|--------------------------------|--|
| Object Type                    | Shows the type of the selected object.   |
| Business Item Identification 1 | Shows the identification of the respective business object.  |
| Revision/Audit Trail Entry     |  |
| Attribute Name                 | Shows the name of the field which changed.   |
| Old Value                      | Shows the old value of an attribute which was subject to a change.   |
| New Value                      | Shows the new value of an attribute after the change.  |
| User                           | Shows the identification of the user who changed the data.   |
| Date and Time                  | Shows the date and time at which the user changed the data.<br><br>Displayed format is: YYYY-MM-DD hh:mm:ss:µsµsµsµsµsµs |

**Buttons**

|         |   |
|---------|---|
| Details | This function enables you to display the details only for: Unlinking/Linking for SI, IPM, IBM.<br><br>The additional detailed information will be present in a pop-up window. |
|---------|---|

## 2.5 Monitoring

### 2.5.1 Monitoring

#### 2.5.1.1 Securities Positions - Search/List Screen

See *Securities Positions – Search/List Screen* [▶ 168].

#### 2.5.1.2 Securities Position - Details Screen

See *Securities Positions – Details Screen* [▶ 173].

### 2.5.1.3 T2S DCA Balances - Search/List Screen

See *T2S DCA Balances – Search/List Screen* [▶ 357].

### 2.5.1.4 T2S DCA Balance - Details Screen

See *T2S DCA Balance – Details Screen* [▶ 361].

## 3 User Instructions Part

### 3.1 General

The user instructions part comprises scenarios adapted from typical user workflows. They are grouped into related activities, called business packages, which are further grouped into categories.

Furthermore, you can find business scenarios dedicated only to the T2S operator are highlighted by the adding 'T2S operator only' in the title.

#### Categories

The categories are a structural element and do not contain any information.

#### Business Packages

The business packages define an overall task. They include an overview and a list of the business scenarios. In detail, each business package description has the same structure and contains the following elements.

#### Overview

The overview describes the aim and the background of the business package. It also explains the interrelation of the business scenarios.

#### List of Business Scenarios

This section contains a list of all business scenarios belonging to the business package.

The list is unordered if the business scenarios represent alternative ways to achieve the aim of the business package. It is ordered if the business scenarios have to be carried out sequentially. Sequential business scenarios do not necessarily have to be carried out directly after each other. The sequence only implies that 1 business scenario is a prerequisite for the following ones.

#### Business Scenarios

Each business scenario represents a single workflow and consists of single action steps, intermediate results and a final result. In detail, each business scenario description has the same structure and contains the following elements.

#### Context of Usage

The context of usage describes the aim of the business scenario and indicates whether this business scenario is mandatory or optional in order to fulfill the overall business package. It also contains the usage restrictions and the pre-requisites (excluding the privileges), if available.

#### Privileges

In this section, all the necessary privileges to access and use the involved screens are listed. First the privileges to access the first screen are mentioned, followed by the privileges necessary to proceed with the business scenario. Afterwards, the privileges for the following screens are mentioned in the same order.

#### Reference

This section lists all references to the screens involved, in order of their appearance in the business scenario.



**Instructions** Each workflow is described from the start to the end, beginning with the access to the starting screen. The instructions involve a number of separate steps which lead you through a series of screens and actions. Each action step is focused on 1 single action. Intermediate results are included and the instructions end with a final result. Possible alternatives and repetitions are highlighted with a notice sign.



---

**Example**

1. Action step 1
  2. Action step 2
    - ➔ Intermediate result
  3. Action step 3
    - ➔ Result
- 

## 3.2 Communication

### 3.2.1 Usage of Broadcasts

**Overview** This business package describes the creation of a new broadcast and how to view existing broadcasts.

To handle broadcasts, carry out the business scenario relevant to you from the list below.

- Business Scenarios**
- Create a new broadcast [[▶ 665](#)]
  - View a broadcast [[▶ 666](#)]

#### 3.2.1.1 Create a New Broadcast

**Context of Usage** This business scenario describes the creation of a new broadcast in T2S. A broadcast is an information message simultaneously available to a selected group of T2S participants. It can either be a general notification or an operational notification of a planned event in the T2S system. A broadcast can be sent to all parties linked to a system entity.

**Privileges** To carry out this business scenario, you need the following privileges:

- Broadcast query
- New broadcast

**References** Further information on screens involved can be found in the screen reference part:

- Broadcasts – search/list* screen [[▶ 616](#)]

- Instructions**
- *Broadcast – new* screen [▶ 621]
  - 1. Go to the *broadcasts – search/list* screen:  
Services >> Communication >> Broadcasts
  - 2. Click on the *new* button.
    - ⇒ The *broadcast – new* screen is displayed.
  - 3. Enter all mandatory information on the screen.



### Alternatives

To set all field to default value and blank out all optional fields, click on the *reset* button.

To cancel the process and return to the previous screen, click on the *cancel* button.

- 4. Click on the *submit* button.
- 2. Enter your PIN for digital signature purposes (NRO).
  - ➔ A new broadcast has been created.

## 3.2.1.2 View a Broadcast

### Context of Usage

This business scenario describes how to search for broadcasts and to view detailed information on a broadcast.



### Hint

A user may only view broadcasts until their validity elapses. The respective expiration date is automatically set to the current business date of creation + three business days.

### Privileges

To carry out this business scenario, you need the following privilege:

- Broadcast query

### References

Further information on screens involved can be found in the screen reference part:

- *Broadcasts – search/list* screen [▶ 616]
- *Broadcast – details* screen [▶ 619]

### Instructions

1. Go to the *broadcasts –search/list* screen:  
Services >> Communication >> Broadcasts
2. Enter the relevant search criteria known to you (e.g. date, subject etc.).
3. Click on the *search* button.
  - ⇒ The search result is displayed in a list on the same screen.

⇒ If the search retrieves only one record, the *broadcast – details* screen is displayed directly.



### Alternative

To set all fields to default value and blank out all optional fields, click on the *re-set* button.

4. Select the broadcast you would like to view in detail by clicking on an entry in the list.
  5. Click on the *details* button.
- ➔ The *broadcasts – details* screen is displayed for the selected record.

## 3.2.2 Monitoring of Communication

### Overview

This business package describes the monitoring of incoming and outgoing files or messages.

It enables you to resend outgoing communication or to check the incoming and outgoing files or messages (e.g. hold/release instructions, settlement instructions, amendment cash instructions) to/from T2S.

To monitor your communication, carry out the business scenarios relevant to you from the list below:

### Business Scenarios

- Resend communication [▶ 667]
- View inbound communication [▶ 668]
- View outbound communication [▶ 669]

### 3.2.2.1 Resend Communication

### Context of Usage

This business scenario describes how to resend communication in case you detect a gap. You can send already sent outbound messages by using a T2S message reference, a message sequence or a range of message sequences again. You may also resend outbound files by entering a sender file reference. This might be necessary if an outbound message or outbound file was lost.

Resending communication is one option for the monitoring of communication.

In order to resend messages or files the same privileges are required as for the initial message or file.

### Privileges

To carry out this business scenario, you need the following privilege:

- Resend communication

### Reference

Further information on screens involved can be found in the screen reference part:

- Instructions**
- Resend communication* screen [▶ 657]
  - 1. Go to the *resend communication* screen:  
Services >> Communication >> Resend Communication
  - 2. Enter all mandatory information about the message or file you want to resend in the 'Resend Communication' frame.



---

### Alternative

To set all fields to default value and blank out all optional fields, click on the *reset* button.

- 
- 3. Click on the *submit* button.
  - ➔ You have resent one or more outbound messages or files.

## 3.2.2.2 View Inbound Communication

**Context of Usage** This business scenario describes how to search for inbound messages and files and to view detailed information on these business items.

Viewing inbound communication is one option for the monitoring of communication.

This business scenario is not relevant for CSD participant and payment bank users.

**Privileges** To carry out this business scenario, you need the following privileges:

- Inbound message list query
- Inbound message details query
- Inbound files list query
- Inbound files details query

**Reference** Further information on screens involved can be found in the screen reference part:

- Inbound messages – search/list* screen [▶ 628]
- Inbound message – details* screen [▶ 635]
- Inbound files – search/list* screen [▶ 622]
- Inbound file – details* screen [▶ 625]

- Instructions**
1. Go to the *inbound messages – search/list* screen:  
Services >> Communication >> Inbound Messages
  2. Enter all search criteria known to you about the inbound message you want to view.
  3. Click on the *search* button.
- ⇒ The *inbound messages – list* screen is displayed.

- ⇒ If the search retrieves only one inbound message, the *inbound message – details* screen is displayed directly.



### Alternative

You can also search for inbound files:

1. Go to the *inbound files – search/list* screen:

Services >> Communication >> Inbound Files

2. Enter all search criteria known to you about the inbound file you want to view. According to your privileges, the party and other search criteria are already filled in.
3. Click on the *search* button.

➔ The *inbound files – list* screen is displayed.

➔ If the search retrieves only one inbound file, the *inbound file – details* screen is displayed directly.



### Alternative

To set all fields to default value and blank out all optional fields, click on the *reset* button.

4. Select the inbound message/file you are looking for by clicking on the entry in the list.
5. Click on the *details* button.

⇒ The *inbound message – details* screen/*inbound file – details* screen is displayed.

➔ You have viewed the details of the selected inbound message or file.



### Hint

With the *inbound file* button on the *inbound message – details* screen and *related inbound messages* button on the *inbound file – details* screen you can directly access the related inbound file or message to your displayed business item.

## 3.2.2.3 View Outbound Communication

### Context of Usage

This business scenario describes how to search for outbound messages and files and to view detailed information on these business items.

Viewing outbound communication is one option for the monitoring of communication.

This business scenario is not relevant for CSD participant and payment bank users.

**Privileges**

To carry out this business scenario, you need the following privileges:

- Outbound message list query
- Outbound message details query
- Outbound files list query
- Outbound files details query

**Reference**

Further information on screens involved can be found in the screen reference part:

- Outbound messages – search/list* screen
- Outbound message – details* screen
- Outbound files – search/list* screen
- Outbound file – details* screen

**Instructions**

1. Go to the *outbound messages – search/list* screen:  
Services >> Communication >> Outbound Messages
2. Enter all search criteria known to you about the outbound message you want to view.
3. Click on the *search* button.
  - ⇒ The *outbound messages – list* screen is displayed.
  - ⇒ If the search retrieves only one outbound message, the *outbound message – details* screen is displayed directly.



---

**Alternative**

You can also search for outbound files:

1. Go to the *Outbound files – search/list* screen:  
Services >> Communication >> Outbound Files
  2. Enter all search criteria known to you about the outbound file you want to view. According to your privileges, the party and other search criteria are already filled in.
  3. Click on the *search* button.
    - ➔ The *outbound files – list* screen is displayed.
    - ➔ If the search retrieves only one outbound file, the *outbound file – details* screen is displayed directly.
-



### Alternative

To set all fields to default value and blank out all optional fields, click on the *reset* button.

4. Select the outbound message/file you are looking for by clicking on the entry in the list.
5. Click on the *details* button.
  - ⇒ The *outbound message – details* screen/*outbound file – details* screen is displayed.
  - ➔ You have viewed the details of the selected outbound message or file.



### Hint

With the *outbound file* button on the *outbound message – details* screen and *related outbound messages* button on the *outbound file – details* screen you can directly access the related outbound file or message to your displayed business item.

## 3.3 Liquidity Transfers

### 3.3.1 Creation of a New Immediate Liquidity Transfer Order

#### Overview

This business package describes the creation of a new liquidity transfer order, in order to transfer liquidity between two T2S dedicated cash accounts or from a T2S dedicated cash account to an external RTGS account.

To create a new liquidity transfer order, carry out the business scenario relevant to you from the list below.

#### Business Scenarios

- Create a new immediate liquidity transfer order
- Copy an immediate liquidity transfer order

#### 3.3.1.1 Copy an Immediate Liquidity Transfer Order

#### Context of Usage

This business scenario describes how to create a new immediate liquidity transfer order which can be an internal liquidity transfer (between T2S dedicated cash accounts) or an outbound liquidity transfer (from a T2S dedicated cash account to an external RTGS account) based on the data of an already executed immediate liquidity transfer.

Copying a new immediate liquidity transfer order is one option for the creation of a new liquidity transfer order.

Before you create a new immediate liquidity transfer order, check whether the account to be debited exists in T2S. In the case of an internal liquidity transfer, check also whether the account to be credited exists in T2S. In the case of an outbound liquidity transfer, check whether the account to be credited is known to T2S.

**Privileges**

To carry out this business scenario, you need the following privileges:

- Immediate liquidity transfer order list query
- Send new liquidity transfer

**Reference**

Further information on screens involved can be found in the screen reference part:

- Immediate liquidity transfer orders – search/list* screen
- Immediate liquidity transfer order – new* screen [▶ 386]

**Instructions**

1. Go to the *immediate liquidity transfer orders – search/list* screen:  
Cash >> Liquidity >> Immediate Liquidity Transfers
2. Enter all search criteria known to you about the immediate liquidity transfer order you want to copy.
3. Click on the *search* button.
  - ⇒ A list containing the search results is displayed on the screen.
4. Select the immediate liquidity transfer order you want to copy by clicking on an entry in the list.
5. Click on the *copy* button.
  - ⇒ The *immediate liquidity transfer order – new* screen is displayed including all the information except for the user reference of the selected liquidity transfer.
6. Check all values of the immediate liquidity transfer and edit them if necessary.

**Alternatives**

To set all fields to default value and blank out all optional fields, click on the *reset* button.

To cancel the process and return to the previous screen, click on the *cancel* button.

7. Click on the *submit* button.
8. Enter your PIN for digital signature purposes (NRO).
  - ➔ A new immediate liquidity transfer order has been created.



## 3.4 Cash and Settlement Monitoring

### 3.4.1 Monitoring of Cash, Collateral and Limits Situation

#### Overview

This business package describes the monitoring of the cash, collateral and limits situation. The aim of this business package is to support your business monitoring. To monitor your cash, collateral and limits situation, carry out the business scenario relevant to you from the list below.

#### Business Scenarios

- View cash balances details and related postings [[▶ 673](#)]
- View cash balances details and related restrictions [[▶ 674](#)]
- View immediate liquidity transfer details [[▶ 675](#)]
- View standing/predefined liquidity transfer order details
- View overall liquidity [[▶ 677](#)]
- Change the limit of a payment bank
- Reimburse an outstanding intraday credit [[▶ 679](#)]

#### 3.4.1.1 View Cash Balances Details and Related Postings

#### Context of Usage

This business scenario describes how to view the cash balance details and related postings allowing you to monitor and manage your balances, for instruction investigations, through queries.

It also allows you to view the instructions impacting particular cash balances during investigation and reconciliation procedures. In order to monitor the cash balances, you can query balances for a given CB or payment bank and then switch to the detailed view for a breakdown by restriction type or postings for a list of relevant instructions. To perform these queries and use these screens you must consult a party with existing T2S dedicated cash accounts.

Viewing cash balances details and related postings is one option for the monitoring of the cash, collateral and limits situation.

#### Privileges

To carry out this business scenario, you need the following privileges:

- T2S dedicated cash account balance query
- T2S dedicated cash account posting query

#### Reference

Further information on screens involved can be found in the screen reference part:

- T2S DCA balances - search/list* screen [[▶ 357](#)]
- T2S DCA balance - details* screen [[▶ 361](#)]
- T2S DCA postings - search/list* screen [[▶ 363](#)]

**Instructions**

1. Go to the *T2S DCA balances – search/list* screen:  
Cash >> Cash Account >> Cash Account Balances
  2. Enter all search criteria known to you about the relevant cash balances you want to view.
  3. Click on the *search* button.
    - ⇒ A list containing the search results is displayed on the screen.
    - ⇒ If the search retrieves only one cash balance, the *T2S DCA balance - details* screen is displayed directly.
  4. Select the cash balance for which you want to view additional details by clicking on an entry in the list.
  5. Click on the *details* button.
    - ⇒ The *T2S DCA balance - details* screen is displayed.
  6. To display the postings related to a particular cash balance detail, select the relevant restriction type by clicking on an entry in the list.
  7. Click on the *postings* button.
    - ⇒ The *T2S DCA postings - search/list* screen is displayed, containing a list of postings including the instruction type and references along with the timestamp.
- ➔ You have viewed the cash balances details and related postings.

### 3.4.1.2 View Cash Balances Details and Related Restrictions

**Context of Usage**

This business scenario describes how to view the cash balance details and related restrictions allowing you to monitor and manage your balances, for restriction use, through queries.

It is relevant for any T2S actors within payments banks, CBs or CSDs who wish to ensure that sufficient funds are present within a particular cash balance before any potential utilisation. It also allows you to view the restriction references available for use within future instructions. In order to monitor the cash balances, you can query balances for a given CB or payment bank and then switch to the detailed view for a breakdown by restriction type or reference. To perform these queries and use these screens you must consult a party with existing T2S dedicated cash accounts.

Viewing cash balances details and related restrictions is one option for the monitoring of the cash, collateral and limits situation.

**Privileges**

To carry out this business scenario, you need the following privileges:

- T2S dedicated cash account balance query

- T2S dedicated cash account balance detailed restrictions query

**Reference**

Further information on screens involved can be found in the screen reference part:

- *T2S DCA balances - search/list* screen [▶ 357]
- *T2S DCA balance - details* screen [▶ 361]
- *Cash restriction details - search/list* screen [▶ 337]

**Instructions**

1. Go to the *T2S DCA balances – search/list* screen:  
Cash >> Cash Account >> Cash Account Balances  
⇒ The *T2S DCA balances - search/list* screen is displayed.
2. Enter all known search criteria known to you about the relevant cash balances you wish to view.
3. Click on the *search* button.  
⇒ A list containing the search results is displayed on the screen.  
⇒ If the search retrieves only one cash balance, the *T2S DCA balance - details* screen is displayed directly.
4. Select the cash balance for which you want to view additional details by clicking on an entry in the list.
5. Click on the *details* button.  
⇒ The *T2S DCA balance – details* screen is displayed.
6. To display the restrictions related to a particular cash balance detail, select the relevant restriction type by clicking on an entry in the list.
7. Click on the *restriction references* button.  
⇒ The *cash restriction details - search/list* screen is displayed, containing a list of the related restriction references and remaining, used and to be pre-empted amounts.  
➔ You have viewed the cash balances details and related restrictions.

### 3.4.1.3 View Immediate Liquidity Transfer Order Details

**Context of Usage**

This business scenario describes how to monitor your immediate liquidity transfer orders which can be internal liquidity transfers (between T2S dedicated cash accounts), inbound liquidity transfers (from an external RTGS account to a T2S dedicated cash account) or outbound liquidity transfers (from a T2S dedicated cash account to an external RTGS account). Furthermore, you can obtain detailed information on a specific immediate liquidity transfer order including general, technical, party and status information.

Viewing immediate liquidity transfer order details is one option for the monitoring of cash, collateral and limits situation.

**Privileges**

To carry out this business scenario, you need the following privileges:

- Immediate liquidity transfer order list query
- Immediate liquidity transfer order detail query

**Reference**

Further information on screens involved can be found in the screen reference part:

- Immediate liquidity transfer orders – search/list* screen [▶ 373]
- Immediate liquidity transfer order – details* screen [▶ 381]

**Instructions**

1. Go to the *immediate liquidity transfer orders – search/list* screen:  
Cash >> Liquidity >> Immediate Liquidity Transfers
2. Enter all search criteria known to you about the immediate liquidity transfer order you want to view. According to your privileges, the party and other search criteria are already filled in. If you have privileges for many accounts, select the search criteria taking into account the intended result.
3. Click on the *search* button.
  - ⇒ A list containing the search results is displayed on the screen.
  - ⇒ If the search retrieves only one immediate liquidity transfer order, the *immediate liquidity transfer order – details* screen is displayed directly.
4. Select any of the ‘Sort By’ criteria of the immediate liquidity transfer order to sort the list. In order to rearrange the sorted list, you can select another ‘Sort By’ criterion at any time.
  - ⇒ The screen is split into different sections according to the selected sorting criterion (e.g. per T2S dedicated account number there will be a section which contains a table with the information of the immediate liquidity transfer orders belonging to one T2S dedicated cash account number).

| Transfers grouped by Dedicated Cash Account Number |               |                          |             |             |                           |                            |        |          |                   |              |                |                     |
|--|---------------|--------------------------|-------------|-------------|---------------------------|----------------------------|--------|----------|-------------------|--------------|----------------|---------------------|
| 100005   |               |                          |             |             |                           |                            |        |          |                   |              |                |                     |
| T2S Dedicated Cash Account Number                  | T2S Reference | Settlement Date and Time | Parent BIC  | Party       | Debit Cash Account Number | Credit Cash Account Number | Amount | Currency | Settlement Status | Sending Time | RTGS Status    | Value Date          |
| 100005   | 7051          | 2012-11-09 15:18:18      | NSBKDEFFAD1 | PMBKDEFFA02 | 100005                    | 100006                     | 0.00   | EUR      | Not executed      | ...          | Not applicable | 2012-10-25 00:00:00 |
| 100005   | 7052          | 9999-01-01 00:00:00      | NSBKDEFFAD1 | PMBKDEFFA02 | 100005                    | 100064                     | 0.00   | EUR      | Not executed      | ...          | Not executed   | 2012-10-25 00:00:00 |
| 100005   | 7053          | 2012-11-09 16:07:15      | NSBKDEFFAD1 | PMBKDEFFA02 | 100005                    | 100064                     | 0.00   | EUR      | Not executed      | ...          | Not executed   | 2012-10-25 00:00:00 |
| 100005   | 7053          | 9999-01-01 00:00:00      | NSBKDEFFAD1 | PMBKDEFFA02 | 100005                    | 100064                     | 0.00   | EUR      | Not executed      | ...          | Not executed   | 2012-10-25 00:00:00 |
| 100005   | 7051          | 2012-11-09 09:18:27      | NSBKDEFFAD1 | PMBKDEFFA02 | 100005                    | 100006                     | 0.00   | EUR      | Not executed      | ...          | Not applicable | 2012-10-25 00:00:00 |
| 100005   | 7082          | 2012-11-09 14:02:32      | NSBKDEFFAD1 | PMBKDEFFA02 | 100005                    | 100006                     | 0.00   | EUR      | Not executed      | ...          | Not applicable | 2012-10-25 00:00:00 |
| 100005   | 7127          | 2012-11-13 18:11:10      | NSBKDEFFAD1 | PMBKDEFFA02 | 100005                    | 100006                     | 0.00   | EUR      | Not executed      | ...          | Not applicable | 2012-10-25 00:00:00 |
| 100005   | 7143          | 9999-01-01 00:00:00      | NSBKDEFFAD1 | PMBKDEFFA02 | 100005                    | 100006                     | 0.00   | EUR      | Not executed      | ...          | Not applicable | 2012-10-25 00:00:00 |
| 100006   |               |                          |             |             |                           |                            |        |          |                   |              |                |                     |
| T2S Dedicated Cash Account Number                  | T2S Reference | Settlement Date and Time | Parent BIC  | Party       | Debit Cash Account Number | Credit Cash Account Number | Amount | Currency | Settlement Status | Sending Time | RTGS Status    | Value Date          |
| 100006   | 7047          | 2012-11-07 18:12:25      | NSBKDEFFAD1 | PMBKDEFFA02 | 100006                    | 100005                     | 0.00   | EUR      | Not executed      | ...          | Not applicable | 2012-10-25 00:00:00 |
| 100006   | 7064          | 2012-11-09 12:05:07      | NSBKDEFFAD1 | PMBKDEFFA02 | 100006                    | 100005                     | 0.00   | EUR      | Not executed      | ...          | Not applicable | 2012-10-25 00:00:00 |

5. Select the immediate liquidity transfer for which you want to view the details by clicking on an entry in the list.
6. Click on the *details* button.
  - ⇒ The *immediate liquidity transfer order – details* screen is displayed.
- ➔ You have viewed the details of the selected immediate liquidity transfer order.

### 3.4.1.4 View Overall Liquidity

#### Context of Usage

This business scenario describes how to view the overall liquidity if you wish to monitor cash through queries. This is mainly relevant for treasurers of credit providers or credit consumers, but also for T2S actors within payments banks, CBs or CSDs enquiring about cash balances and limits.

In order to monitor the cash situation, you can view the overall liquidity for a given CB or payment bank and then switch to the detailed view to view the components of the available liquidity. You then have the option to view the limit utilisation for the same credit consumer(s) to identify the collateral limits which are soon reached and those which are unused. You can also view the cash forecast for the same credit consumer(s) to identify any potential lack of cash. You may then react to the overall liquidity by any necessary increases or decreases to your cash balances or limits.

To perform these queries and use these screens you must be a user of a party which is a credit consumer or credit provider with existing T2S dedicated cash accounts and their associated limits.

#### Privileges

To carry out this business scenario, you need the following privileges:

- T2S overall liquidity query
- Limit utilisation query
- Limit utilisation journal query
- Cash forecast query

#### Reference

Further information on screens involved can be found in the screen reference part:

- Overall liquidity – search/list* screen [▶ 396]
- Limit utilisation – search/list* screen [▶ 348]
- Limit utilisation journal – search/list* screen [▶ 352]
- Cash forecast – search/list* screen [▶ 323]
- Cash forecast – details* screen [▶ 331]

#### Instructions

1. Go to the *overall liquidity – search/list* screen:  
Cash >> Liquidity >> T2S Overall Liquidity
2. Enter the relevant party and parent BIC for which you want to view liquidity information.



#### Hint

If you are a CB user, you can restrict the view to one payment bank by entering its party BIC.



### Alternative

To set all fields to default value and blank out all optional fields, click on the *re-set* button.

3. Click on the *search* button.
  - ⇒ An overview list containing the the limit, its utilisation and available liquidity per party is displayed on the screen.
4. To display all the components of the available liquidity, those related to collateral as well as those related to cash balances, click on the *detailed list* button.
  - ⇒ A detailed list is displayed on the screen, containing the collateral value, available cash, blocked cash and reserved cash. The available liquidity of the previous screen is calculated as the sum of the cash balances and the minimum of the auto-collateralisation headroom (difference between the auto-collateralisation limit and its utilisation) and the collateral value.
5. To focus on the components related to collateral, go to the *limit utilisation – search/list* screen:  
Cash >> Cash Accounts >> Limit Utilisations
6. Enter the same party and parent BIC as in step 2.
7. Click on the *search* button.
  - ⇒ A list containing the search results is displayed on the screen showing the credit consumers' limit, utilisation and headroom for each credit provider and T2S dedicated cash account.
8. To display the journal of the collateral usage, select the relevant account by clicking on an entry in the list.
9. Click on the *journal of limit utilisation* button.
  - ⇒ The *limit utilisation journal – search/list* screen is displayed, showing the impact of each instruction on the limit utilisation and headroom.
10. To focus on the components related to the cash balances, go to the *cash forecasts – search/list* screen:  
Cash >> Cash Accounts >> Cash Forecasts
11. Enter the same party and parent BIC as in step 2 as well as all other mandatory information.
12. Click on the *search* button.
  - ⇒ A list containing the search results is displayed, containing the cash forecast reflecting the sum of the projected cash balance and outstanding collateral for each party.

13. To display the details of the cash forecast, select the relevant cash forecast by clicking on an entry in the list.
14. Click on the *details* button.
  - ⇒ The *cash forecast – details* screen is displayed, showing the global cash forecast and the details for each T2S dedicated cash account.
  - ➔ You have obtained an overview of the different cash components allowing you to monitor the overall liquidity of your cash situation. You may then react to this overall situation by adapting your buy sell strategies, injecting cash or making limit adjustments.

### 3.4.1.5 Reimburse an Outstanding Intraday Credit

#### Context of Usage

This business scenario describes how to reimburse an outstanding intraday credit. This is done by first finding all reverse collateral instructions generated by T2S during auto-collateralisation that are still on party hold. Once identified, these reverse collateral instructions are released by changing the party hold status to false. Finding and releasing these instructions is necessary to enable their settlement. Settlement instructions put on party hold are not eligible for settlement until they are released. The settlement of these instructions results in the reimbursement of the related intraday credit.

A settlement instruction is eligible to be released for party hold if it is not cancelled, settled nor already released for party hold. You can check the status of your settlement instruction before creating the release instruction through the details screen as described in the business scenario view settlement instruction details [▶ 701].

Reimbursing an outstanding intraday credit is one option for the monitoring of cash, collateral and limits situation.

This business scenario is not relevant for CB users.

#### Privileges

To carry out this business scenario, you need the following privileges:

- Settlement instruction query
- Settlement instruction current status query
- Settlement instruction status audit trail query
- Release party hold settlement instruction on a securities account or on behalf of an external CSD
- Send new instruction using a specific instructing party

#### Reference

Further information on screens involved can be found in the screen reference part:

- Settlement instructions – search/list* screen

**Instructions**

- *Settlement instruction – details* screen
  - *Hold/release instruction - new* screen [▶ 125]
1. Go to the *settlement instructions - search/list* screen:  
Securities >> Settlement >> Settlement Instructions
  2. Enter all mandatory search criteria enabling you to find all the reverse collateral instructions generated by T2S for auto-collateralisation that are currently on party hold. This includes all instructions where the security transaction type is either COLI or COLO and the party hold status is 'YES'.
  3. Click on the *search* button.
    - ⇒ A list containing the search results is displayed on the screen.
    - ⇒ If the search retrieves only one settlement instruction, the *settlement instruction - details* screen is displayed directly. Proceed with step 6.
  4. Select the settlement instruction on party hold you want to release by clicking on an entry in the list.
  5. Click on the *details* button.
    - ⇒ The *settlement instruction – details* screen is displayed.
  6. Check the details of the settlement instruction and click on the *hold/release* button.
    - ⇒ The *hold/release instruction – new* screen is displayed.
  7. Enter all mandatory information in the 'General' subframe.
  8. Select the 'Party Release' check box in the 'Hold/Release' subframe.

| Current Hold Status                    | Hold Types                             | Release Types                                      |
|--|--|--|
| Party Hold Status<br>Hold              | Party Hold<br><input type="checkbox"/> | Party Release<br><input type="checkbox"/>          |
| CSD Hold Status<br>Released            | CSD Hold<br><input type="checkbox"/>   | CSD Release<br><input type="checkbox"/>            |
| CSD Validation Hold Status<br>Released |  | CSD Validation Release<br><input type="checkbox"/> |
| CoSD Hold Status<br>Released           |  | CoSD Release<br><input type="checkbox"/>           |
|  |  | CoSD Rule Identification *                         |

9. Click on the *submit* button.
  - ➔ A new release instruction for party hold has been created relating to the T2S generated settlement instruction for the reimbursement of intraday credit.

### 3.4.2 Monitoring of Securities Positions

**Overview**

This business package describes the monitoring of securities positions.



To monitor your securities positions, carry out the business scenario relevant to you from the list below.

**Business Scenarios**

- View current securities positions and related postings [▶ 681]
- View current securities positions and related restrictions [▶ 682]
- View historic securities positions for a specific period [▶ 684]
- View historic securities positions on a specific date [▶ 683]

### 3.4.2.1 View Current Securities Positions and Related Postings

**Context of Usage**

This business scenario describes how to view the details of securities positions and related postings allowing you to monitor and manage your positions. For reconciliation purpose, you may have to retrieve the instructions impacting particular securities positions. To achieve this, you query positions for a given CSD or settlement bank and then switch to the detailed breakdown by postings for a list of the relevant instructions.

Viewing current securities positions and related postings is one option for the monitoring of securities positions.

**Privileges**

To carry out this business scenario, you need the following privileges:

- Securities account position query
- Securities posting query

**Reference**

Further information on screens involved can be found in the screen reference part:

- Securities positions - search/list* screen [▶ 168]
- Securities position – details* screen [▶ 173]
- Securities postings - search/list* screen [▶ 81]

**Instructions**

1. Go to the *securities positions – search/list* screen:  
`Securities >> Securities Account >> Securities Positions`
2. Enter all search criteria known to you about the securities positions you want to view.
3. Click on the *search* button.
  - ⇒ A list containing the search results is displayed on the screen, showing the securities account, ISIN, restriction type, date, currency and total quantity.
  - ⇒ If the search retrieves a single securities position, the *securities positions – details* screen is displayed directly. Proceed with step 6.
4. Select the securities position for which you want to view additional details by clicking on an entry in the list.

5. Click on the *details* button.
    - ⇒ The *securities position – details* screen is displayed, showing the details of the securities position by restriction type including the quantity to be pre-empted in the case of reservations.
  6. To view the postings related to a particular securities position detail, select the relevant restriction type by clicking on an entry in the list.
  7. Click on the *postings* button.
    - ⇒ The *securities postings – search/list* screen is displayed, showing a list of postings for the selected securities position including the instruction type and references along with the timestamp.
- ➔ You have viewed your securities positions and related postings.

### 3.4.2.2 View Current Securities Positions and Related Restrictions

#### Context of Usage

This business scenario describes how to view the details of securities positions and related restrictions allowing you to monitor and manage your positions. You can investigate your securities positions to ensure that sufficient securities are present within a particular blocked, reserved or earmarked position before any potential utilisation. You can also view the restriction references available for use within future instructions. To achieve this, you query positions for a given CSD or settlement bank and then switch to the detailed view for a breakdown by restriction type and reference.

Viewing current securities positions and related restrictions is one option for the monitoring of securities positions.

#### Privileges

To carry out this business scenario, you need the following privileges:

- Securities account position query
- Securities position detailed restriction details query

#### Reference

Further information on screens involved can be found in the screen reference part:

- Securities positions - search/list* screen [▶ 168]
- Securities position – details* screen [▶ 173]
- Securities restriction detail – search/list* screen [▶ 85].

#### Instructions

1. Go to the *securities positions – search/list* screen:  
`Securities >> Securities Account >> Securities Positions`
  - ⇒ The *securities positions search/list* screen is displayed.
2. Enter all search criteria known to you about the securities positions you want to view.

3. Click on the *search* button.
    - ⇒ A list containing the search results is displayed on the screen, showing the securities account, ISIN, restriction type, date, currency and total quantity.
    - ⇒ If the search retrieves a single securities position, the *securities positions – details* screen is displayed directly. Proceed with step 6.
  4. Select the securities position for which you want to view additional details by clicking on an entry in the list.
  5. Click on the *details* button.
    - ⇒ The *securities positions – details* screen is displayed, showing the details of the securities position by restriction type including the quantity to be pre-empted in the case of reservations.
  6. To view the restrictions related to a particular securities position detail, select the relevant restriction type by clicking on an entry in the list.
  7. Click on the *restriction references* button.
    - ⇒ The *securities restriction detail – search/list* screen is displayed, showing a list of the detailed securities restrictions for the selected securities position including the related restriction reference and remaining, used and to-be pre-empted quantities.
- ➔ You have viewed your securities positions and related restrictions.

### 3.4.2.3 View Historic Securities Positions for a Specific Date

#### Context of Usage

This business scenario describes how to view the details of securities positions for a specific date allowing you to monitor and manage your positions. You can enquire about securities positions or perform investigations and reconciliations on particular positions. In order to monitor the securities positions, you can query positions for a given CSD or settlement bank and then switch to the detailed view for a breakdown by restriction type.

Viewing historic securities positions is one option for the monitoring of securities positions.

#### Privileges

To carry out this business scenario, you need the following privilege:

- Securities account position query

#### Reference

Further information on screens involved can be found in the screen reference part:

- Securities positions - search/list* screen [▶ 168]
- Securities position – details* screen [▶ 173]

- Instructions**
1. Go to the *securities positions – search/list* screen:  
Securities >> Securities Account >> Securities Positions
  2. Enter all search criteria about the securities positions you want to view, including the same relevant past date in both the 'Date From' and 'Date To' fields.
  3. Click on the *search* button.
    - ⇒ A list containing the search results is displayed on the screen, showing the securities account, ISIN, restriction type, date, currency and total quantity.
    - ⇒ If the search retrieves a single securities position, the *securities position – details* screen is displayed directly.
  4. Select the securities position for which you want to view additional details by clicking on an entry in the list.
  5. Click on the *details* button.
    - ⇒ The *securities positions – details* screen is displayed, showing the details of the securities position by restriction type including the quantity to be pre-empted in the case of reservations.
    - ➔ You have viewed your historic securities positions details.

### 3.4.2.4 View Historic Securities Positions for a Specific Period

**Context of Usage** This business scenario describes how to view the details of securities positions for a specific period allowing you to monitor and manage your positions. Using queries, you can enquire about the evolution of securities positions over a given time period while performing investigations and reconciliations on particular positions. In order to monitor the securities positions, you can query positions for a given CSD or settlement bank and then switch to the detailed view for a breakdown by restriction type.

Viewing historic securities positions for a specific period is one option for the monitoring of securities positions.

**Privileges** To carry out this business scenario, you need the following privilege:

- Securities account position query

**Reference** Further information on screens involved can be found in the screen reference part:

- Securities positions - search/list* screen [▶ 168]
- Securities position – details* screen [▶ 173]

- Instructions**
1. Go to the *securities positions – search/list* screen:  
Securities >> Securities Account >> Securities Positions

2. Enter all search criteria about the securities positions you want to view, including the relevant period by specifying different past dates in the 'Date From' and 'Date To' fields.
  3. Click on the *search* button.
    - ⇒ A list containing the search results is displayed on the screen, showing the securities account, ISIN, restriction type, date, currency and total quantity.
    - ⇒ If the search retrieves a single securities position, the *securities position – details* screen is displayed directly.
  4. Select the securities position for which you want to view additional details by clicking on an entry in the list.
  5. Click on the *details* button.
    - ⇒ The *securities positions - details* screen is displayed, showing the details of the securities position by restriction type including the quantity to be pre-empted in the case of reservations.
- ➔ You have viewed your historic securities positions for a specific period.

## 3.5 Settlement Instructions

### 3.5.1 Creation of a New Settlement Instruction

#### Overview

This business package describes the creation of a new settlement instruction.

You can create a new settlement instruction either introducing all the necessary information, copying it from an already existing settlement instruction or responding an allegation instruction. Once the instruction has been created, you can also check its lifecycle in T2S.

To create a new settlement instruction, carry out the business scenarios in the predefined order and choose the business scenario relevant to you whenever options are given.

#### Business Scenarios

1. Create a new settlement instruction
  - Enter a settlement instruction [▶ 686]
  - Copy a settlement instruction [▶ 690]
  - Respond to an allegation instruction [▶ 696]
2. View instruction details
  - View settlement instruction details [▶ 701]
  - View allegation settlement instruction details [▶ 702]

### 3.5.1.1 Enter a Settlement Instruction

|                         |   |
|-------------------------|---|
| <b>Context of Usage</b> | <p>This business scenario describes how to create a new settlement instruction.</p> <p>Entering a new settlement instruction is one option for the creation of a new settlement instruction [▶ 685].</p> <p>This business scenario is not relevant for CB users.</p>  |
| <b>Privileges</b>       | <p>To carry out this business scenario, you need the following privileges:</p> <ul style="list-style-type: none"><li><input type="checkbox"/> Settlement instruction query</li><li><input type="checkbox"/> Settlement instruction current status query</li><li><input type="checkbox"/> Settlement instruction status audit trail query</li><li><input type="checkbox"/> Send new settlement instruction/settlement restriction on securities either on a securities account or on behalf of an external CSD</li><li><input type="checkbox"/> Send new instruction using a specific instructing party</li><li><input type="checkbox"/> Send settlement instruction with non-modifiable flag activated</li><li><input type="checkbox"/> Link to an instruction/pool reference belonging to a specific party</li><li><input type="checkbox"/> Use ISO transaction code AUTO (auto-collateralisation)</li><li><input type="checkbox"/> Use ISO transaction code BYIY (buy-in)</li><li><input type="checkbox"/> Use ISO transaction code BSBK (buy sell back)</li><li><input type="checkbox"/> Use ISO transaction code CLAI (market claim)</li><li><input type="checkbox"/> Use ISO transaction code CNCB (central bank collateral operation)</li><li><input type="checkbox"/> Use ISO transaction code COLI (collateral in)</li><li><input type="checkbox"/> Use ISO transaction code COLO (collateral out)</li><li><input type="checkbox"/> Use ISO transaction code CONV (depository receipt conversion)</li><li><input type="checkbox"/> Use ISO transaction code CORP (corporate action)</li><li><input type="checkbox"/> Use ISO transaction code ETFT (exchange traded funds)</li><li><input type="checkbox"/> Use ISO transaction code FCTA (factor update)</li><li><input type="checkbox"/> Use ISO transaction code INSP (move of stock)</li><li><input type="checkbox"/> Use ISO transaction code ISSU (issuance)</li><li><input type="checkbox"/> Use ISO transaction code MKDW (mark down)</li><li><input type="checkbox"/> Use ISO transaction code MKUP (mark up)</li><li><input type="checkbox"/> Use ISO transaction code NETT (netting)</li><li><input type="checkbox"/> Use ISO transaction code NSYN (non syndicated)</li><li><input type="checkbox"/> Use ISO transaction code OWNE (external account transfer)</li><li><input type="checkbox"/> Use ISO transaction code OWNI (internal account transfer)</li></ul> |

- Use ISO transaction code PAIR (pair off)
- Use ISO transaction code PLAC (placement)
- Use ISO transaction code PORT (portfolio move)
- Use ISO transaction code REAL (realignment)
- Use ISO transaction code REDI (withdrawal)
- Use ISO transaction code REDM (redemption)
- Use ISO transaction code RELE (depository receipt release cancellation)
- Use ISO transaction code REPU (repo)
- Use ISO transaction code RODE (return delivery without matching)
- Use ISO transaction code RVPO (reverse repurchase agreement)
- Use ISO transaction code SBBK (sell buy back)
- Use ISO transaction code SBRE (borrowing reallocation)
- Use ISO transaction code SECB (securities borrowing)
- Use ISO transaction code SECL (securities lending)
- Use ISO transaction code SLRE (lending reallocation)
- Use ISO transaction code SUBS (subscription)
- Use ISO transaction code SWIF (switch from)
- Use ISO transaction code SWIT (switch to)
- Use ISO transaction code SYND (syndicate underwriters)
- Use ISO transaction code TBAC (TBA closing)
- Use ISO transaction code TRAD (trade)
- Use ISO transaction code TRPO (triparty repo)
- Use ISO transaction code TRVO (triparty reverse repo)
- Use ISO transaction code TURN (turnaround)
- Party hold settlement instruction on a securities account or on behalf of an external CSD
- CSD hold settlement instruction either on a securities account or on behalf of the CSD in T2S

**Reference** Further information on screens involved can be found in the screen reference parts:

- Settlement instructions– search/list* screen
- Settlement instruction - new* screen [▶ 210]

**Instructions**

1. Go to the *settlement instructions– search/list* screen:  
Securities >> Settlement >> Settlement Instructions

2. Click on the *new* button.
  - ⇒ The *settlement instruction - new* screen is displayed.
3. Enter all mandatory information about the settlement instruction you want to create in the 'General Information', and the 'Detailed Information' frame.
4. Optionally, you can enter additional information about the settlement instruction into the optional fields in all the available frames.
5. To link your settlement instruction to another instruction, click on the *add row* button to add a new link.

6. Select and add all the requested information to identify the instruction you want your settlement instruction to be linked with. Once all the information is introduced click on the *submit changes* icon in the 'Options' column.

- ⇒ The link has been added to the list.
7. If you want to add your settlement restriction on securities to a pool, enter the 'Pool Identification' field, 'Pool Instruction Counter' and the 'Pool Reference Owner BIC' field instead.



**Repetition**

To add more links, repeat steps 5 to 6.

8. To remove a link from the list of links to be added to the settlement instruction, click on the *delete row* icon in the 'Options' column.



⇒ The link has been deleted from the list of links.

- To add a restriction, click on the *add row* icon to add a new restriction reference.

- Enter the restriction reference you want to make use of and click on the *submit changes* icon in the 'Options' column.

⇒ A new restriction reference has been added to the list.



### Repetition

To add more restrictions, repeat steps 9 and 10.

- To remove a restriction reference from the list of restriction references to be added to the settlement instruction, click on the *delete row* icon in the 'Options' column.

⇒ The restriction reference has been deleted from the list of restriction references.

- To enter additional data related to the parties involved in the settlement instruction, click on the *add row* icon in the 'Additional Receiving Parties' and/or 'Additional Delivering Parties' frames and enter all relevant information.

- To add additional information, select the value from the 'Level 1' drop-down menu in the 'Additional Information' frame.

- Continue this selection within the interdependent menus from the 'Level 2' drop-down menu till the 'Level 6' drop-down menu.

Each level is dependent on the next level in a successive order. The content of the select boxes varies through the different levels.

15. Once you have selected all the relevant levels, introduce the value and click on the *add row* icon.

| Level 1            | Level 2     | Level 3                 |
|--------------------|-------------|-------------------------|
| CashParties        | Debtor      | AlternateIdentification |
| Level 4            | Level 5     | Level 6                 |
| IdentificationType | Proprietary | Issuer                  |

Value \*

| Path                         | Value | Options |
|------------------------------|-------|---------|
| No additional info added yet |       |         |

- ⇒ The additional information has been added to the list.



### Repetition

To add more additional information paths, repeat steps 14 to 15.

16. To remove an entry from the list of additional information to be added to the settlement instruction, click on the *delete row* icon in the 'Options' column.

- ⇒ The entry has been deleted from the list of additional information.



### Alternatives

To set all fields to default value and blank out all optional fields, click on the *reset* button.

To cancel the process and return to the previous screen, click on the *cancel* button.

17. Click on the *submit* button.

18. Enter your PIN for digital signature purposes (NRO).

- ➔ The new settlement instruction has been created.

## 3.5.1.2 Copy a Settlement Instruction

### Context of Usage

This business scenario describes how to copy a settlement instruction based on an existing T2S settlement instruction in order to deliver or receive securities and/or cash between your own accounts or between one of your accounts and a counterpart's account, based on already executed settlement.

Copying an existing settlement instruction is one option for the creation of a new settlement instruction.

This business scenario is not relevant for CB users.

### Privileges

To carry out this business scenario, you need the following privileges:

- Settlement instruction query
- Settlement instruction current status query

- Settlement instruction status audit trail query
- Send new settlement instruction/settlement restriction on securities either on a securities account or on behalf of an external CSD
- Send new instruction using a specific instructing party
- Send settlement instruction with non-modifiable flag activated
- Link to an instruction/pool reference belonging to a specific party
- Use ISO transaction code AUTO (Auto-Collateralisation)
- Use ISO transaction code BSBK (Buy Sell Back)
- Use ISO transaction code CLAI (Market Claim)
- Use ISO transaction code CNCB (Central Bank Collateral Operation)
- Use ISO transaction code COLI (Collateral In)
- Use ISO transaction code COLO (Collateral Out)
- Use ISO transaction code CONV (Depository Receipt Conversion)
- Use ISO transaction code CORP (Corporate Action)
- Use ISO transaction code ETFT (Exchange Traded Funds)
- Use ISO transaction code FCTA (Factor Update)
- Use ISO transaction code INSP (Move Of Stock)
- Use ISO transaction code ISSU (Issuance)
- Use ISO transaction code MKDW (Mark Down)
- Use ISO transaction code MKUP (Mark Up)
- Use ISO transaction code NETT (Netting)
- Use ISO transaction code NSYN (Non Syndicated)
- Use ISO transaction code OWNE (External Account Transfer)
- Use ISO transaction code OWNI (Internal Account Transfer)
- Use ISO transaction code PAIR (Pair Off)
- Use ISO transaction code PLAC (Placement)
- Use ISO transaction code PORT (Portfolio Move)
- Use ISO transaction code REAL (Realignment)
- Use ISO transaction code REDI (Withdrawal)
- Use ISO transaction code REDM (Redemption)
- Use ISO transaction code RELE (Depository Receipt Release Cancellation)
- Use ISO transaction code REPU (Repo)
- Use ISO transaction code RODE (Return Delivery Without Matching)

- Use ISO transaction code RVPO (Reverse Repo)
- Use ISO transaction code SBBK (Sell Buy Back)
- Use ISO transaction code SBRE (Borrowing Reallocation)
- Use ISO transaction code SECB (Securities Borrowing)
- Use ISO transaction code SECL (Securities Lending)
- Use ISO transaction code SLRE (Lending Reallocation)
- Use ISO transaction code SUBS (Subscription)
- Use ISO transaction code SYND (Syndicate Underwriters)
- Use ISO transaction code TBAC (TBA Closing)
- Use ISO transaction code TRAD (Trade)
- Use ISO transaction code TRPO (Triparty Repo)
- Use ISO transaction code TRVO (Triparty Reverse Repo)
- Use ISO transaction code TURN (Turnaround)
- Party hold settlement instruction on a securities account or on behalf of an external CSD
- CSD hold settlement instruction either on a securities account or on behalf of the CSD in T2S

**Reference** Further information on screens involved can be found in the screen reference part:

- Settlement instructions – search/list* screen
- Settlement instruction - details* screen
- Settlement instruction - new* screen [▶ 210]

**Instructions**

1. Go to the *settlement instructions – search/list* screen:  
Securities >> Settlement >> Settlement Instructions
2. Enter the information known to you about the settlement instruction you want to copy. At least one field of the general criteria frame has to be specified to perform the search.
3. Click on the *search* button.
  - ⇒ The *settlement instructions – search/list* screen is displayed. A list containing the search results is displayed on the screen.
  - ⇒ If the search retrieves a single settlement instruction, the *settlement instruction - details* screen is displayed directly, proceed with step 6.
4. Select the settlement instruction you want to copy by clicking on an entry in the list.
5. Click on the *details* button.

- ⇒ The *settlement instruction - details* screen is displayed.
- 6. Click on the *copy row* icon.
  - ⇒ The *settlement instruction - new* screen is displayed taking by default the following fields from the original instruction: instructing party BIC, instructing party parent BIC, intended settlement date, trade date, priority, allowed modification flag, partial settlement indicator, threshold type, ISIN, securities description, securities account number, settlement quantity, settlement type, payment type code, credit/debit code, dedicated cash account, settlement amount, currency, delivering depository, delivering CSD participant information, client of the delivering CSD participant, receiving depository, receiving CSD participant, client of the receiving CSD participant.
- 7. Check if all the default values that have been copied from the settlement instruction in all the available frames are right for the new settlement instruction or modify them if needed.
- 8. Check that all mandatory information in the mandatory fields of the 'General Information' and the 'Detailed Information' frame is filled in. If not, enter all mandatory information.
- 9. Optionally, you can enter additional information about the settlement instruction into the optional fields in all the available frames.
- 10. To link your settlement instruction to another instruction, click on the *add row* icon to add a new link.

| Link Type        | Reference Type | Reference | Reference Owner | Options |
|------------------|----------------|-----------|-----------------|---------|
| No records found |                |           |                 |         |
| +                |                |           |                 |         |

Pool Instruction Reference:

Pool Instruction Counter:

Pool Reference Owner BIC:

- 11. Select and add all the requested information to identify the instruction you want your settlement instruction to be linked to. Once all the information is introduced click on the *submit changes* icon in the 'Options' column.

| Link Type | Reference Type | Reference            | Reference Owner      | Options |
|-----------|----------------|----------------------|----------------------|---------|
| ...       | ...            | <input type="text"/> | <input type="text"/> | ✓       |
| +         |                |                      |                      |         |

Pool Instruction Reference:

Pool Instruction Counter:

Pool Reference Owner BIC:

- ⇒ The link has been added to the list.

12. If you want to add your settlement restriction on securities to a pool, enter the 'Pool Identification' field, 'Pool Instruction Counter' field and the 'Pool Reference Owner BIC' field instead.

The screenshot shows a table titled 'Link' with the following columns: Link Type, Reference Type, Reference, Reference Owner, and Options. The table currently displays 'No records found'. Below the table, there are three input fields: 'Pool Instruction Reference', 'Pool Instruction Counter', and 'Pool Reference Owner BIC'. These fields are highlighted with a red box.



### Repetition

To add more links, repeat steps 10 to 11.

13. To remove a link from the list of links to be added to the settlement instruction, click on the *delete row* icon in the 'Options' column.

⇒ The link has been deleted from the list of links.

14. To add a restriction, click on the *add row* icon to add a new restriction reference.

The screenshot shows a table titled 'Use of Restriction' with the following columns: Restriction Reference and Options. The table currently displays 'No records found'. Below the table, there is a '+' icon, which is highlighted with a red box.

15. Enter the restriction reference you want to make use of and click on the *submit changes* icon in the 'Options' column.

⇒ A new restriction reference has been added to the list.



### Repetition

To add more restrictions, repeat steps 14 and 15.

16. To remove a restriction reference from the list of restriction references to be added to the settlement instruction, click on the *delete row* icon in the 'Options' column.

⇒ The restriction reference has been deleted from the list of restriction references.

17. To enter additional data related to the parties involved in the settlement instruction, click on the *add row* icon in the 'Additional Receiving Parties' and/or 'Additional Delivering Parties' frames and enter all relevant information.

18. To add additional information, select the value from the 'Level 1' drop-down menu in the 'Additional Information' frame.
19. Continue this selection within the interdependent menus from the 'Level 2' drop-down menu till the 'Level 6' drop-down menu. Each level depends on the next in a successive order. The content of the select boxes varies through the different levels.
20. Once you have selected all the relevant levels, fill in the value and click on the *add row* icon.

⇒ The additional information has been added to the list.



### Repetition

To add more additional information paths, repeat steps 19 to 20.

21. To remove an entry from the list of additional information to be added to the settlement instruction, click on the *delete row* icon in the 'Options' column.

⇒ The entry has been deleted from the list of additional information.



### Alternatives

To set all fields to default value and blank out all optional fields, click on the *reset* button.

To cancel the process and return to the previous screen, click on the *cancel* button.

22. Click on the *submit* button.

23. Enter your PIN for digital signature purposes (NRO).

- ➔ The new settlement instruction has been created based on a copied settlement instruction.

### 3.5.1.3 Respond to an Allegement Instruction

#### Context of Usage

This business scenario describes how to create a new settlement instruction based on the information provided by an allegement instruction. When receiving an allegement instruction, T2S indicates you that there is a settlement instruction alleged against you. To confirm it, you need to respond to the allegement by creating your settlement instruction.

Responding to an allegement instruction is one option for the creation of a new settlement instruction.

This business scenario is not relevant for CB users.

#### Privileges

To carry out this business scenario, you need the following privileges:

- Allegement query
- Send new settlement instruction/settlement restriction on securities either on a securities account or on behalf of an external CSD
- Send new instruction using a specific instructing party
- Send settlement instruction with non-modifiable flag activated
- Link to an instruction/pool reference belonging to a specific party
- Use ISO transaction code AUTO (auto-collateralisation)
- Use ISO transaction code BSBK (buy sell back)
- Use ISO transaction code CLAI (market claim)
- Use ISO transaction code CNCB (central bank collateral operation)
- Use ISO transaction code COLI (collateral in)
- Use ISO transaction code COLO (collateral out)
- Use ISO transaction code CONV (depository receipt conversion)
- Use ISO transaction code CORP (corporate action)
- Use ISO transaction code ETFT (exchange traded funds)
- Use ISO transaction code FCTA (factor update)
- Use ISO transaction code INSP (move of stock)
- Use ISO transaction code ISSU (issuance)
- Use ISO transaction code MKDW (mark down)
- Use ISO transaction code MKUP (mark up)



- Use ISO transaction code NETT (netting)
- Use ISO transaction code NSYN (non syndicated)
- Use ISO transaction code OWNE (external account transfer)
- Use ISO transaction code OWNI (internal account transfer)
- Use ISO transaction code PAIR (pair off)
- Use ISO transaction code PLAC (placement)
- Use ISO transaction code PORT (portfolio move)
- Use ISO transaction code REAL (realignment)
- Use ISO transaction code REDI (withdrawal)
- Use ISO transaction code REDM (redemption)
- Use ISO transaction code RELE (depository receipt release cancellation)
- Use ISO transaction code REPU (repo)
- Use ISO transaction code RODE (return delivery without matching)
- Use ISO transaction code RVPO (reverse repo)
- Use ISO transaction code SBBK (sell buy back)
- Use ISO transaction code SBRE (borrowing reallocation)
- Use ISO transaction code SECB (securities borrowing)
- Use ISO transaction code SECL (securities lending)
- Use ISO transaction code SLRE (lending reallocation)
- Use ISO transaction code SUBS (subscription)
- Use ISO transaction code SYND (syndicate underwriters)
- Use ISO transaction code TBAC (TBA closing)
- Use ISO transaction code TRAD (trade)
- Use ISO transaction code TRPO (triparty repo)
- Use ISO transaction code TRVO (triparty reverse repo)
- Use ISO transaction code TURN (turnaround)
- Party hold settlement instruction on a securities account or on behalf of an external CSD
- CSD hold settlement instruction either on a securities account or on behalf of the CSD in T2S

**Reference**

Further information on screens involved can be found in the screen reference part:

- Allegement instructions – search/list* screen [▶ 89]
- Allegement instruction – details* screen [▶ 93]

**Instructions**

□ *Settlement instruction – new screen* [▶ 210]

1. Go to the *allegement instructions – search/list* screen:  
Securities >> Settlement >> Settlement Instruction Allegements
2. Enter all search criteria known to you about the allegement instruction you want to respond to.
3. Click on the *search* button.
  - ⇒ A list containing the search results is displayed on the screen.
  - ⇒ If the search retrieves only one allegement instruction, the *allegement instruction - details* screen is displayed directly. Proceed with step 6.
4. Select the allegement instruction you want to respond to by clicking on an entry in the list.
5. Click on the *details* button.
  - ⇒ The *allegement instruction - details* screen is displayed.
6. Click on the *new settlement instruction* button.
  - ⇒ The *settlement instruction - new* screen is displayed, taking by default the following fields from the original instruction: trade date, intended settlement date, cash amount, currency, securities quantity, ISIN, partial settlement indicator, securities transaction type.
7. Check if the copied default values are right for the new settlement instruction or modify them if needed.
8. Check that all mandatory fields of the ‘General Information’ and the ‘Detailed Information’ frames are filled in. If not, enter all mandatory information.
9. Optionally, you can enter additional information about the settlement instruction into the optional fields in all the available frames.
10. To link your settlement instruction to another instruction, click on the *add row* icon to add a new link.

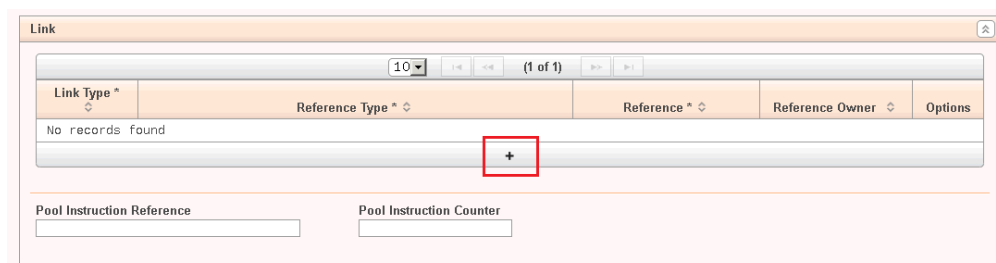

- Select and add all the requested information to identify the instruction you want your settlement instruction to be linked with. Once all the information is filled in click on the *submit changes* icon in the 'Options' column.

The screenshot shows a window titled "Link" with a table. The table has five columns: "Link Type", "Reference Type", "Reference", "Reference Owner", and "Options". The "Options" column contains a checkmark and a delete icon. Below the table are two input fields: "Pool Instruction Reference" and "Pool Instruction Counter".

⇒ The link has been added to the list.

- If you want to add your settlement instruction to a pool, enter the pool identification and the pool instruction counter instead.

The screenshot shows a window titled "Link" with a table. The table has five columns: "Link Type", "Reference Type", "Reference", "Reference Owner", and "Options". The table is empty with the text "No records found". Below the table are two input fields: "Pool Instruction Reference" and "Pool Instruction Counter".



### Repetition

To add more links, repeat steps 10 to 11.

- To remove a link from the list of links to be added to the settlement instruction, click on the *delete row* icon in the 'Options' column.

⇒ The link has been deleted from the list of links.

- To add a restriction, click on the *add row* icon to add a new restriction reference.

The screenshot shows a window titled "Use of Restriction" with a table. The table has two columns: "Restriction Reference" and "Options". The table is empty with the text "No records found". Below the table is an input field for "Pool Instruction Reference" and an "add row" icon.

- Enter the restriction reference you want to make use of and click on the *submit changes* icon in the 'Options' column.

⇒ A new restriction reference has been added to the list.



### Repetition

To add more restrictions, repeat steps 14 and 15.

16. To remove a restriction reference from the list of restriction references to be added to the settlement instruction, click on the *delete row* icon in the 'Options' column.
  - ⇒ The restriction reference has been deleted from the list of restriction references.
17. To enter additional data related to the parties involved in the settlement instruction, click on the *add row* icon in the 'Additional Receiving Parties' and/or 'Additional Delivering Parties' frames and enter all relevant information.

18. To add additional information, select the value from the 'Level 1' drop-down menu in the 'Additional Information' frame.
19. Continue this selection within the interdependent menus from the 'Level 2' drop-down menu till the 'Level 6' drop-down menu. Each level depends on the next in a successive order. The content of the drop-down menu varies through the different levels.
20. Once you have selected all the relevant levels, enter the value and click on the *add row* icon.

- ⇒ The additional information has been added to the list.



### Repetition

To add more additional information paths, repeat steps 19 to 20.

21. To remove an entry from the list of additional information to be added to the settlement instruction, click on the *delete row* icon in the 'Options' column.
  - ⇒ The entry has been deleted from the list of additional information.



### Alternatives

To set all fields to default value and blank out all optional fields, click on the *reset* button.

To cancel the process and return to the previous screen, click on the *cancel* button.

22. Click on the *submit* button.

23. Enter your PIN for digital signature purposes (NRO).

➔ The new settlement instruction has been created.

## 3.5.1.4 View Settlement Instruction Details

### Context of Usage

This business scenario describes how to view the details of a settlement instruction.

Once a settlement instruction is created in T2S it might be necessary for you to check its details to be aware of updates during the lifecycle of the settlement instruction.

Viewing settlement instruction details is optional for the creation of a new settlement instruction.

This business scenario is not relevant for CB users.

### Privileges

To carry out this business scenario, you need the following privileges:

- Settlement instruction query
- Settlement instruction current status query

### Reference

Further information on screens involved can be found in the screen reference part:

- Settlement instructions – search/list* screen
- Settlement instruction – details* screen

### Instructions

1. Go to the *settlement instructions – search/list* screen:  
Securities >> Settlement >> Settlement Instructions
2. Enter at least one general search criterion known to you about the settlement instruction for which you want to view the details.
3. Click on the *search* button.
  - ⇒ A list containing the search results is displayed on the screen.
  - ⇒ If the search retrieves only one settlement instruction, the *settlement instruction – details* screen is displayed directly.

**Alternative**

To set all fields to default value and blank out all optional fields, click on the *re-set* button.

4. Select the settlement instruction for which you want to view the details by clicking on the entry in the list.
5. Click on the *details* button.
  - ⇒ The *settlement instruction – details* screen is displayed.
  - ➔ You have viewed the settlement instruction details.

### 3.5.1.5 View Allegement Settlement Instruction Details

**Context of Usage**

This business scenario describes how to view the details of an allegement instruction. Once the allegement instruction is created in T2S it might be necessary for you to check its status.

Viewing allegement settlement instruction details is optional for the creation of a new settlement instruction.

This business scenario is not relevant for CB users.

**Privileges**

To carry out this business scenario, you need the following privilege:

- Allegement query

**Reference**

Further information on screens involved can be found in the screen reference part:

- Allegement instructions – search/list* screen [▶ 89]
- Allegement instruction - details* screen [▶ 93]

**Instructions**

1. Go to the *allegement instructions – search/list* screen:  
Securities >> Settlement >> Settlement Instruction Allegements
2. Enter all search criteria known to you about the allegement instruction for which you want to view the details.

**Alternative**

To set all fields to default value and blank out all optional fields, click on the *re-set* button.

3. Click on the *search* button.
  - ⇒ A list containing the search results is displayed on the screen.
  - ⇒ If the search retrieves only one allegement instruction, the *allegement instruction - details* screen is displayed directly.

4. Select the allegation instruction for which you want to view the details by clicking on an entry in the list.
5. Click on the *details* button.
  - ⇒ The *allegation instruction - details* screen is displayed.
  - ➔ You have viewed the allegation settlement instruction details.

## 3.5.2 Creation of a New Amendment Instruction for a Settlement Instruction

### Overview

This business package describes the creation of a new amendment instruction for a settlement instruction.

You can create a new amendment instruction for a settlement instruction and afterwards, you can also check the information of the amendment instruction in T2S.

To create a new amendment instruction for a settlement instruction, carry out the business scenarios in the predefined order and choose the business scenario relevant to you whenever options are given.

### Business Scenarios

1. Create a new amendment instruction for a settlement instruction
  - Add a link for a settlement instruction [▶ 703]
  - Amend the partial settlement indicator for a settlement instruction [▶ 706]
  - Amend the priority for a settlement instruction [▶ 707]
  - Remove a link for a settlement instruction [▶ 709]
2. View amendment instruction for a settlement instruction details [▶ 711]

### 3.5.2.1 Add a Link for a Settlement Instruction

### Context of Usage

This business scenario describes how to link a settlement instruction in order to settle it at the same time, after or before another settlement instruction or settlement restriction.

Adding a link for a settlement instruction is one option for the creation of an amendment instruction for a settlement instruction.

Before you add a link for your settlement instruction, check whether the settlement instruction is neither cancelled, partially settled, settled nor on CoSD hold.

You can check the status of your settlement instruction before creating the amendment instruction through the details screen as described in the business scenario view settlement instruction details [▶ 701].

The number of links that can be added per amendment instruction is unbounded.

This business scenario is not relevant for NCB users.

- Privileges** To carry out this business scenario, you need the following privileges:
- Settlement instruction query
  - Settlement instruction current status query
  - Settlement instruction status audit trail query
  - Send new instruction using a specific instructing party
  - Link to an instruction/pool reference belonging to a specific party
  - Amend process indicator of a settlement instruction / settlement restriction on securities either on a securities account or on behalf of the CSD in T2S or on behalf of an external CSD
  - Amend process indicator of a non-modifiable settlement instruction on behalf of the instructing party of the underlying instruction
- Reference** Further information on screens involved can be found in the screen reference part:
- Settlement instructions – search/list* screen
  - Settlement instruction - details* screen
  - Amendment securities instruction - new* screen [▶ 102]
- Instructions**
1. Go to the *settlement instructions – search/list* screen:  
Securities >> Settlement >> Settlement Instructions
  2. Enter the relevant information about the settlement instruction you want to link.
  3. Click on the *search* button.
    - ⇒ The *settlement instructions – search/list* screen is displayed.
    - ⇒ If the search retrieves a single settlement instruction, the *settlement instruction - details* screen is displayed directly. Proceed with step 6.
  4. Select the settlement instruction you want to amend by clicking on an entry in the list.
  5. Click on the *details* button.
    - ⇒ The *settlement instruction - details* screen is displayed.
  6. Click on the *amendment instruction* button in the button bar.
    - ⇒ The *amendment securities instruction - new* screen is displayed.
  7. Enter all mandatory information in the 'General' frame.
  8. Select the *linkage information* radio button, located on the lower center side of the *amendment securities instruction - new* screen.



Amendment Type

Priority  Linkage Information  Partial Settlement Indicator



⇒ The 'Linkage Information' and the 'Link' frames are displayed.

9. Select the *link* radio button to add a link.

The screenshot shows a window titled 'Linkage Information'. Inside, there are two radio buttons: 'LINK' (which is selected) and 'UNLINK'.

10. Click on the *add row* icon in the 'Link' frame to display the links related input fields.

The screenshot shows a window titled 'Link'. It contains a table with the following columns: 'Link Type', 'Reference Type', 'Reference', 'Reference Owner', and 'Options'. The table currently has one row with the text 'No records found'. A red box highlights a '+' icon in the 'Options' column of this row.

11. Enter the relevant information to identify the instruction you want your instruction to be linked with in the 'Link' frame and click on the *submit changes* icon in the 'Options' column.

The screenshot shows the 'Link' frame with a new row added. The row has input fields for 'Link Type', 'Reference Type', 'Reference', and 'Reference Owner'. A red box highlights the entire row, and a red arrow points to a submit icon (a checkmark inside a circle) in the 'Options' column.

⇒ The link has been added to the list.

12. To remove an entry from the list of links to be added, click on the *delete row* icon in the 'Options' column.

⇒ The link has been deleted from the list.



### Repetition

To add more links, repeat steps 10 to 11.

You can add as many links as you like.



### Alternatives

To set default criteria and blank out all optional fields, click on the *reset* button.

To cancel the process and return to the previous screen, click on the *cancel* button.

13. Click on the *submit* button.

14. Enter your PIN for digital signature purposes (NRO).

➔ A new amendment instruction to add a link for a settlement instruction has been created.

## 3.5.2.2 Amend the Partial Settlement Indicator for a Settlement Instruction

### Context of Usage

This business scenario describes how to amend the partial settlement indicator for a settlement instruction. You can create a new amendment instruction for your settlement instruction to change its partial settlement indicator and threshold type.

Amending the partial settlement indicator is one option for the creation of an amendment instruction for a settlement instruction.

Before you amend the partial settlement indicator for your settlement instruction, check whether it is neither cancelled nor settled nor on CoSD hold. In addition, partial settlement is not possible for linked settlement instructions. You can check the status of your settlement instruction before creating the amendment instruction through the details screen as described in the business scenario view settlement instruction details [▶ 701].

### Privileges

To carry out this business scenario, you need the following privileges:

- Settlement instruction query
- Settlement instruction current status query
- Settlement instruction status audit trail query
- Send new instruction using a specific instructing party
- Link to an instruction/pool reference belonging to a specific party
- Amend process indicator of a settlement instruction / settlement restriction on securities either on a securities account or on behalf of the CSD in T2S or on behalf of an external CSD
- Amend process indicator of a non-modifiable settlement instruction on behalf of the instruction party of the underlying instruction

### Reference

Further information on screens involved can be found in the screen reference part:

- Settlement instructions – search/list* screen
- Settlement instruction – details* screen
- Amendment securities instruction – new* screen [▶ 102]

### Instructions

1. Go to the *settlement instructions – search/list* screen:  
Securities >> Settlement >> Settlement Instructions
2. Enter at least one general search criterion known to you about the settlement instruction for which you want to amend the partial settlement indicator.
3. Click on the *search* button.
  - ⇒ A list containing the search results is displayed on the *settlement instructions – search/list* screen.

- ⇒ If the search retrieves a single settlement instruction, the *settlement instruction – details* screen is displayed directly. Proceed with step 6.
4. Select the settlement instruction you want to amend by clicking on an entry in the list.
  5. Click on the *details* button.

⇒ The *settlement instruction – details* screen is displayed.
  6. Click on the *amendment instruction* button, located on the lower lefthand side of the *settlement instruction – details* screen.

⇒ The *amendment securities instruction – new* screen is displayed.
  7. Click on the *partial settlement indicator* radio button, located on the lower right hand side of the *amendment securities instruction - new* screen.



- ⇒ The *partial settlement indicator* frame is displayed.
8. Select the new partial settlement indicator from the drop-down menu.



### Alternatives

To set all fields to default criteria and blank out all optional fields, click on the *reset* button.

To cancel the process and return to the previous screen, click on the *cancel* button.

9. Click on the *submit* button.
10. Enter your PIN for digital signature purposes (NRO).

➔ A new amendment instruction to change the partial settlement indicator has been created.

### 3.5.2.3 Amend the Priority for a Settlement Instruction

#### Context of Usage

This business scenario describes how to amend the priority for a settlement instruction. You can create a new amendment instruction to amend the priority for your settlement instruction to prioritise or delay its settlement.

Amending the priority for a settlement instruction is one option for the creation of an amendment instruction for a settlement instruction.

Before you amend the priority for a settlement instruction, check whether it is neither cancelled nor settled nor on CoSD Hold. You can check the status of your settlement instruction before creating the amendment instruction, through the *details* screen as described in the business scenario view settlement instruction details [▶ 701].

This business scenario is not relevant for CB users.

## Privileges

To carry out this business scenario, you need the following privileges:

- Link to an instruction/pool reference belonging to a specific party
- Settlement instruction query
- Settlement instruction current status query
- Settlement instruction audit trail query
- Send new instruction using a specific instructing party
- Amend process indicator of a settlement instruction/settlement restriction on securities either on a securities account or on behalf of the CSD in T2S or on behalf of an external CSD
- Amend process indicator of a non-modifiable settlement instruction on behalf of the instructing party of the underlying instruction

## Reference

Further information on screens involved can be found in the screen reference part:

- Settlement instructions – search/list* screen
- Settlement instruction – details* screen
- Amendment securities instruction - new* screen [▶ 102]

## Instructions

1. Go to the *settlement instructions – search/list* screen:  
Securities >> Settlement >> Settlement Instructions
2. Enter all search criteria known to you about the settlement instruction for which you want to amend the priority.
3. Click on the *search* button.
  - ⇒ A list containing the search results is displayed on the screen.
  - ⇒ If the search retrieves only one settlement instruction, the *settlement instruction – details* screen is displayed directly. Proceed with step 6.
4. Select the settlement instruction for which you want to amend the priority by clicking on an entry in the list.
5. Click on the *details* button.
  - ⇒ The *settlement instruction – details* screen is displayed.
6. Check the current priority value and click on the *amendment instruction* button.

⇒ The *amendment securities instruction – new* screen is displayed.

7. Click on the *priority* radio button, located on the lower left-hand side of the screen.

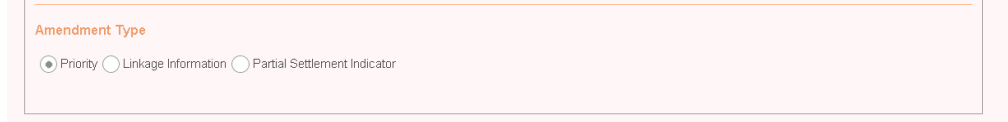

Amendment Type

Priority  Linkage Information  Partial Settlement Indicator

⇒ The 'Priority' frame is displayed.

8. Select the new priority from the drop-down menu.



Priority

Priority Level \*

High  
Normal  
Reserved



### Alternatives

To set default criteria and blank out all optional fields, click on the *reset* button.

To cancel the process and return to the previous screen, click on the *cancel* button.

9. Click on the *submit* button.
  10. Enter your PIN for digital signature purposes (NRO).
- ➔ A new amendment instruction to change the priority has been created.

## 3.5.2.4 Remove a Link for a Settlement Instruction

### Context of Usage

This business scenario describes how to remove an existing link in a settlement instruction.

Removing a link for a settlement instruction is one option for the creation of a new amendment instruction for a settlement instruction.

Before you remove a link for your settlement instruction, check whether it is neither settled nor cancelled. You can check the status of your settlement instruction before creating the amendment instruction through the details screen as described in the business scenario view settlement instruction details [▶ 701].

The number of links that can be removed per amendment instruction is limited to the number of existing linkages in the settlement instruction.

If you want to modify an already existing link in your settlement instruction, you have first to remove the existing link and then add a new link to your settlement instruction.

This business scenario is not relevant for CB users.

### Privileges

To carry out this business scenario, you need the following privileges:

- Settlement instruction query

- Settlement instruction current status query
- Settlement instruction status audit trail query
- Link to an instruction/pool reference belonging to a specific party
- Amend process indicator of a settlement instruction/settlement restriction on securities either on a securities account or on behalf of the CSD in T2S or on behalf of an external CSD
- Amend process indicator of a non-modifiable settlement instruction on behalf of the instructing party of the underlying instruction
- Send new instruction using a specific instructing party

**Reference**

Further information on screens involved can be found in the screen reference part:

- Settlement instructions – search/list* screen
- Settlement instruction – details* screen
- Amendment securities instruction – new* screen [▶ 102]

**Instructions**

1. Go to the *settlement instructions – search/list* screen:  
Securities >> Settlement >> Settlement Instructions
2. Enter all search criteria known to you about the settlement instruction you want to amend.
3. Click on the *search* button.
  - ⇒ A list containing the search results is displayed on the screen.
  - ⇒ If the search retrieves only one settlement instruction, the *settlement instructions – details* screen is displayed directly. Proceed with step 6.
4. Select the settlement instruction you want to amend by clicking on an entry in the list.
5. Click on the *details* button.
  - ⇒ The *settlement instruction – details* screen is displayed.
6. Click on the *amendment instruction* button, located on the lower left-hand side of the screen.
  - ⇒ The *amendment securities instruction – new* screen is displayed.
7. Enter all mandatory information in the 'General' subframe.
8. Click on the *linkage information* radio button, located on the lower center side of the *amendment securities instruction – new* screen.

Amendment Type

Priority  Linkage Information  Partial Settlement Indicator

- ⇒ The 'Linkage Information' and 'Link' frames are displayed.

9. Select the *unlink* radio button.



⇒ The existing links of the referenced settlement instruction are displayed in the 'Link' frame below.

10. Select the link(s) to be removed from the list.



### Alternatives

To set default criteria and blank out all optional fields, click on the *reset* button. To cancel the process and return to the previous screen, click on the *cancel* button.

11. Click on the *submit* button.

12. Enter your PIN for digital signature purposes (NRO).

➔ A new amendment instruction to remove a link for a settlement instruction has been created.

## 3.5.2.5 View Amendment Instruction for a Settlement Instruction Details

### Context of Usage

This business scenario describes how to view the details of an amendment instruction for a settlement instruction. Once an amendment instruction for a settlement instruction has been created in T2S it might be necessary for you to check its details to be aware of updates during the lifecycle of the amendment instruction.

Viewing an amendment instruction for a settlement instruction is optional for the creation of a new amendment instruction for a settlement instruction.

This business scenario is not relevant for CB users.

### Privileges

To carry out this business scenario, you need the following privileges:

- Maintenance for intra-position movements and settlement instructions query
- Amendment instruction query for intra-position movements and settlement instructions

### Reference

Further information on screens involved can be found in the screen reference part:

- Maintenance securities instructions – search/list* screen [▶ 163]
- Amendment securities instruction – details* screen [▶ 97]

**Instructions**

1. Go to the *maintenance securities instructions – search/list* screen:  
Securities >> Settlement >> Maintenance Securities Instructions
2. Enter all search criteria known to you about the amendment instruction for a settlement instruction for which you want to view the details.
3. Select the value 'Settlement Instruction' in the 'Instruction Type' field.

4. Select the value 'Amendment Instruction' in the 'Maintenance Instruction Type' field.



**Alternative**

To set all fields to default value and blank out all optional fields, click on the *reset* button.

5. Click on the *search* button.
  - ⇒ A list containing the search results is displayed on the screen.
  - ⇒ If the search retrieves only one amendment instruction for a settlement instruction, the *amendment securities instruction – details* screen is displayed directly.
6. Select the amendment instruction for a settlement instruction for which you want to view the details by clicking on an entry in the list.
7. Click on the *details* button.
  - ⇒ The *amendment securities instruction – details* screen is displayed.
- ➔ You have viewed the details of an amendment instruction for a settlement instruction.



### 3.5.3 Creation of a New Hold/Release Instruction for a Settlement Instruction

#### Overview

This business package describes the creation of a new hold/release instruction for a settlement instruction.

You can create a new hold/release instruction and afterwards check the information of the hold/release instruction in T2S.

To create a new hold/release instruction for a settlement instruction, carry out the business scenarios in the predefined order and choose the business scenario relevant to you whenever options are given:

#### Business Scenarios

1. Create a new hold instruction
  - Put a settlement instruction on party hold [▶ 713]
  - Put a settlement instruction on CSD hold [▶ 715]
2. Create a new release instruction
  - Release a settlement instruction from party hold [▶ 717]
  - Release a settlement instruction from CSD hold [▶ 720]
  - Release a settlement instruction from CoSD hold [▶ 722]
  - Release a settlement instruction from CSD validation hold [▶ 724]
3. View hold/release instruction details [▶ 725]

#### 3.5.3.1 Put a Settlement Instruction on Party Hold

#### Context of Usage

This business scenario describes how to put a settlement instruction on party hold through the creation of a hold instruction. Settlement instructions put on party hold are not eligible for settlement until they are released. This is necessary if you want to prevent the settlement instruction to be settled.

Putting a settlement instruction on party hold is one option for the creation of a new hold/release instruction for a settlement instruction.

Before you create a new hold instruction for party hold, check whether the settlement instruction is eligible for party hold. A settlement instruction is eligible to be put on party hold if it is not cancelled, settled, already put on party hold nor identified as CoSD. You can check the status of your settlement instruction before creating the hold instruction through the details screen as described in the business scenario view settlement instruction details [▶ 701].

This business scenario is not relevant for CB users.

#### Privileges

To carry out this business scenario, you need the following privileges:

- Settlement instruction query
- Settlement instruction current status query

- Settlement instruction status audit trail query
- Party hold settlement instruction on a securities account or on behalf of an external CSD
- Send new instruction using a specific instructing party

**Reference**

Further information on screens involved can be found in the screen reference part:

- Settlement instructions – search/list* screen
- Settlement instruction – details* screen
- Hold/release instruction - new* screen [▶ 125]

**Instructions**

1. Go to the *settlement instructions – search/list* screen:  
Securities >> Settlement >> Settlement Instructions
2. Enter at least one general search criterion known to you about the settlement instruction you want to put on party hold.
3. Click on the *search* button.
  - ⇒ A list containing the search results is displayed on the screen.
  - ⇒ If the search retrieves only one settlement instruction, the *settlement instruction – details* screen is displayed directly. Proceed with step 6.
4. Select the settlement instruction you want to put on party hold by clicking on an entry in the list.
5. Click on the *details* button.
  - ⇒ The *settlement instruction – details* screen is displayed.
6. Check the details of the settlement instruction and click on the *hold/release* button.
  - ⇒ The *hold/release instruction – new* screen is displayed.
7. Enter all mandatory information in the ‘General’ subframe.
8. Select the ‘Party Hold’ check box in the ‘Hold/Release’ subframe.

| Current Hold Status                    | Hold Types  | Release Types                                      |
|--|---|--|
| Party Hold Status<br>Released          | Party Hold<br><input checked="" type="checkbox"/> | Party Release<br><input type="checkbox"/>          |
| CSD Hold Status<br>Released            | CSD Hold<br><input type="checkbox"/>              | CSD Release<br><input type="checkbox"/>            |
| CSD Validation Hold Status<br>Released |   | CSD Validation Release<br><input type="checkbox"/> |
| CoSD Hold Status<br>Released           |   | CoSD Release<br><input type="checkbox"/>           |
|  |   | CoSD Rule Identification<br><input type="text"/>   |



### Alternative

To set all fields to default value and blank out all optional fields, click on the *reset* button.

To cancel the process and return to the previous screen, click on the *cancel* button.

9. Click on the *submit* button.

10. Enter your PIN for digital signature purposes (NRO).

➔ A new hold instruction for party hold has been created.

## 3.5.3.2 Put a Settlement Instruction on CSD Hold

### Context of Usage

This business scenario describes how to put a settlement instruction on CSD hold through the creation of a hold instruction. This is necessary if you want to prevent the settlement instruction to be settled. Settlement instructions put on CSD hold are not eligible for settlement until they are released.

Putting a settlement instruction on CSD hold is one option for the creation of a new hold/release instruction for a settlement instruction.

Before you create a new hold instruction for CSD hold, check whether the settlement instruction is eligible for CSD hold. A settlement instruction is eligible to be put on CSD hold if it is not cancelled, settled, already put on CSD hold nor identified as CoSD. You can check the status of your settlement instruction before creating the hold instruction through the details screen as described in the business scenario view settlement instruction details [▶ 701].

This business scenario is not relevant for CB users.

### Privileges

To carry out this business scenario, you need the following privileges:

- Settlement instruction query
- Settlement instruction current status query
- Settlement instruction status audit trail query
- CSD hold settlement instruction either on a securities account or on behalf of the CSD in T2S
- Send new instruction using a specific instructing party

### Reference

Further information on screens involved can be found in the screen reference part:

- Settlement instructions - search/list* screen
- Settlement instruction - details* screen
- Hold/release instruction - new* screen [▶ 125]

**Instructions**

1. Go to the *settlement instructions – search/list* screen:  
Securities >> Settlement >> Settlement Instructions
2. Enter at least one general search criterion known to you about the settlement instruction you want to put on CSD hold.
3. Click on the *search* button.
  - ⇒ A list containing the search results is displayed on the screen.
  - ⇒ If the search retrieves only one settlement instruction, the *settlement instruction - details* screen is displayed directly. Proceed with step 6.
4. Select the settlement instruction you want to put on CSD hold by clicking on an entry in the list.
5. Click on the *details* button.
  - ⇒ The *settlement instruction – details* screen is displayed.
6. Check the details of the settlement instruction and click on the *hold/release* button.
  - ⇒ The *hold/release instruction – new* screen is displayed.
7. Enter all mandatory information in the ‘General’ subframe.
8. Select the ‘CSD Hold’ check box in the ‘Hold/Release’ subframe.

| Current Hold Status                    | Hold Types                                      | Release Types                                      |
|--|---|--|
| Party Hold Status<br>Released          | Party Hold<br><input type="checkbox"/>          | Party Release<br><input type="checkbox"/>          |
| CSD Hold Status<br>Released            | CSD Hold<br><input checked="" type="checkbox"/> | CSD Release<br><input type="checkbox"/>            |
| CSD Validation Hold Status<br>Released |   | CSD Validation Release<br><input type="checkbox"/> |
| CoSD Hold Status<br>Released           |   | CoSD Release<br><input type="checkbox"/>           |

CoSD Rule Identification

**Alternative**

To set all fields to default value and blank out all optional fields, click on the *reset* button.

To cancel the process and return to the previous screen, click on the *cancel* button.

9. Click on the *submit* button.
10. Enter your PIN for digital signature purposes (NRO).
  - ➔ A new hold instruction for CSD hold has been created.

### 3.5.3.3 Release a Settlement Instruction from Party Hold

#### Context of Usage

This business scenario describes how to release a settlement instruction from party hold. This is necessary if you want to release a settlement instruction that was previously put on party hold, in order to settle it. Settlement instructions put on party hold are not eligible for settlement until they are released.

Releasing a settlement instruction for party hold is one option for the creation of a new hold/release instruction for a settlement instruction.

Before you create a new release instruction for party hold, check whether the settlement instruction is eligible for the release from party hold. A settlement instruction is eligible to be released for party hold if it is not cancelled, settled nor already released for party hold. You can check the status of your settlement instruction before creating the release instruction through the details screen as described in the business scenario view settlement instruction details [▶ 701].

This business scenario is not relevant for CB users.

#### Privileges

To carry out this business scenario, you need the following privileges:

- Settlement instruction query
- Settlement instruction current status query
- Settlement instruction status audit trail query
- Release party hold settlement instruction on a securities account or on behalf of an external CSD
- Release party hold auto-collateralisation instruction on a securities account
- Send new instruction using a specific instructing party

#### Reference

Further information on screens involved can be found in the screen reference part:

- Settlement instructions – search/list* screen
- Settlement instruction – details* screen
- Hold/release instruction - new* screen [▶ 125]

#### Instructions

1. Go to the *settlement instructions – search/list* screen:  
Securities >> Settlement >> Settlement Instructions
2. Enter at least one general search criterion known to you about the settlement instruction you want to release from party hold.
3. Click on the *search* button.
  - ⇒ A list containing the search results is displayed on the screen.
  - ⇒ If the search retrieves only one settlement instruction, the *settlement instruction - details* screen is displayed directly. Proceed with step 6.

4. Select the settlement instruction you want to release for a party hold by clicking on an entry in the list.
5. Click on the *details* button.
  - ⇒ The *settlement instruction – details* screen is displayed.
6. Check the details of the settlement instruction and click on the *hold/release* button.
  - ⇒ The *hold/release instruction – new* screen is displayed.
7. Enter all mandatory information in the ‘General’ subframe.
8. Select the ‘Party Release’ check box in the ‘Hold/Release’ subframe.

| Current Hold Status                    | Hold Types                             | Release Types  |
|--|--|--|
| Party Hold Status<br>On Hold           | Party Hold<br><input type="checkbox"/> | Party Release<br><input checked="" type="checkbox"/> |
| CSD Hold Status<br>Released            | CSD Hold<br><input type="checkbox"/>   | CSD Release<br><input type="checkbox"/>              |
| CSD Validation Hold Status<br>Released |  | CSD Validation Release<br><input type="checkbox"/>   |
| CoSD Hold Status<br>Released           |  | CoSD Release<br><input type="checkbox"/>             |
|  |  | CoSD Rule Identification *<br><input type="text"/>   |



### Alternative

To set all fields to default value and blank out all optional fields, click on the *reset* button.

To cancel the process and return to the previous screen, click on the *cancel* button.

9. Click on the *submit* button.
10. Enter your PIN for digital signature purposes (NRO).
  - ➔ A new release instruction for party hold has been created.

## 3.5.3.4 Partially Release a Settlement Instruction from Party Hold

### Context of Usage

This business scenario describes how to partially release a settlement instruction from party hold. This is necessary if you want to partially release a settlement instruction that was previously put on party hold, in order to partially settle it. Settlement instructions put on party hold are not eligible for partial settlement until they are released or partially released.

Before you create a new partial release instruction for party hold, check whether the settlement instruction is eligible for the release from party hold. A business settlement instruction is eligible to be partially released for party hold if it is the delivering leg of the transaction, it is matched, its ISD has been reached, it is not cancelled, settled, already released for party hold and no other hold applies to the transaction. You can check the status of your settlement instruction before creating the partial release instruction through the details screen as described in the business scenario View Settlement Instruction Details [▶ 701].

This business scenario is not relevant for CB users.

### Privileges

To carry out this business scenario, you need the following privileges:

- Settlement instruction query
- Settlement instruction current status query
- Settlement instruction status audit trail query
- Release party hold settlement instruction on a securities account or on behalf of an external CSD
- Release party hold auto-collateralisation instruction on a securities account
- Send new instruction using a specific instructing party

### Reference

Further information on screens involved can be found in the screen reference part:

- Settlement Instructions - Search/List Screen [▶ 176]
- Settlement Instruction - Details Screen [▶ 191]
- Hold/Release Instruction - New Screen [▶ 125]

### Instructions

1. Go to the settlement instructions – search/list screen: Securities >> Settlement >> Settlement Instructions
2. Enter at least one general search criterion known to you about the settlement instruction you want to release from party hold.
3. Click on the search button.
  - ⇒ A list containing the search results is displayed on the screen.
  - ⇒ If the search retrieves only one settlement instruction, the settlement instruction - details screen is displayed directly. Proceed with step 6.
4. Select the settlement instruction you want to release for a party hold by clicking on an entry in the list.
5. Click on the details button.
  - ⇒ The settlement instruction – details screen is displayed.
6. Check the details of the settlement instruction and click on the hold/release button.

⇒ The hold/release instruction – new screen is displayed.

7. Enter all mandatory information in the 'General' subframe.
8. Select the 'Party Release' check box in the 'Hold/Release' subframe.
9. Insert the quantity to be released in the 'Released quantity' field.



#### Alternative

To set all fields to default value and blank out all optional fields, click on the reset button.

To cancel the process and return to the previous screen, click on the cancel button.

10. Click on the submit button.
  11. Enter your PIN for digital signature purposes (NRO).
- ➔ A new partial release instruction for party hold has been created.

### 3.5.3.5 Release a Settlement Instruction from CSD Hold

#### Context of Usage

This business scenario describes how to release a settlement instruction from CSD hold. Settlement instructions put on CSD hold are not eligible for settlement until they are released. This is necessary if you want to release a settlement instruction that was previously put on CSD hold, in order to settle it.

Releasing a settlement instruction for CSD hold is one option for the creation of a new hold/release instruction for a settlement instruction.

Before you create a new release instruction for CSD hold, check whether the settlement instruction is eligible for the release from CSD hold. A settlement instruction is eligible for CSD hold release if it is not cancelled, settled, or already released from CSD hold. You can check the status of your settlement instruction before creating the release instruction through the details screen as described in the business scenario view settlement instruction details [▶ 701].

This business scenario is not relevant for CB users.

#### Privileges

To carry out this business scenario, you need the following privileges:

- Settlement instruction query
- Settlement instruction current status query
- Settlement instruction status audit trail query
- Release CSD hold settlement instruction either on a securities account or on behalf of the CSD in T2S
- Send new instruction using a specific instructing party



**Reference** Further information on screens involved can be found in the screen reference part:

- Settlement instructions – search/list* screen
- Settlement instruction – details* screen
- Hold/release instruction - new* screen [▶ 125]

**Instructions**

1. Go to the *settlement instructions – search/list* screen:  
Securities >> Settlement >> Settlement Instructions
2. Enter at least one general search criterion known to you about the settlement instruction you want to release from CSD hold.
3. Click on the *search* button.
  - ⇒ A list containing the search results is displayed on the screen.
  - ⇒ If the search retrieves only one settlement instruction, the *settlement instruction – details* screen is displayed directly. Proceed with step 6.
4. Select the settlement instruction you want to release from CSD hold by clicking on an entry in the list.
5. Click on the *details* button.
  - ⇒ The *settlement instruction – details* screen is displayed.
6. Check the details of the settlement instruction and click on the *hold/release* button.
  - ⇒ The *hold/release instruction – new* screen is displayed.
7. Enter all mandatory information in the ‘General’ subframe.
8. Select the ‘CSD Release’ check box in the ‘Hold/Release’ subframe.

| Current Hold Status                    | Hold Types                             | Release Types                                      |
|--|--|--|
| Party Hold Status<br>Released          | Party Hold<br><input type="checkbox"/> | Party Release<br><input type="checkbox"/>          |
| CSD Hold Status<br>On Hold             | CSD Hold<br><input type="checkbox"/>   | CSD Release<br><input checked="" type="checkbox"/> |
| CSD Validation Hold Status<br>Released |  | CSD Validation Release<br><input type="checkbox"/> |
| CoSD Hold Status<br>Released           |  | CoSD Release<br><input type="checkbox"/>           |
|  |  | CoSD Rule Identification *<br><input type="text"/> |

**Alternative**

To set all fields to default value and blank out all optional fields, click on the *re-set* button.

To cancel the process and return to the previous screen, click on the *cancel* button.

9. Click on the *submit* button.
10. Enter your PIN for digital signature purposes (NRO).
  - ➔ A new release instruction for CSD hold has been created.

### 3.5.3.6 Release a Settlement Instruction from CoSD Hold

#### Context of Usage

This business scenario describes how to release a settlement instruction from CoSD hold. This process is necessary if you want to release a settlement instruction that was previously put on CoSD hold, in order to settle it. Settlement instructions put on CoSD hold are not eligible for settlement until they are released.

Releasing a settlement instruction for CoSD hold is one option for the creation of a new hold/release instruction for a settlement instruction.

Before you create a new release instruction for CoSD hold, check whether the settlement instruction is eligible for the release of CoSD hold. A settlement instruction is eligible to be released from CoSD hold if it is not cancelled, settled, already released for CoSD hold or if the settlement restrictions of the type CoSD blocking related to the CoSD process have not been settled yet. You can check the status of your settlement instruction before creating the release instruction through the details screen as described in the business scenario view settlement instruction details [▶ 701].

This business scenario is not relevant for CB users.

#### Privileges

To carry out this business scenario, you need the following privileges:

- Settlement instruction query
- Settlement instruction current status query
- Settlement instruction status audit trail query
- Release CoSD rule of settlement instruction on behalf of administering party
- Send new instruction using a specific instructing party

#### Reference

Further information on screens involved can be found in the screen reference part:

- Settlement instructions – search/list* screen
- Settlement instruction – details* screen
- Hold/release instruction - new* screen [▶ 125]

#### Instructions

1. Go to the *settlement instructions – search/list* screen:  
Securities >> Settlement >> Settlement Instructions
2. Enter at least one general search criterion known to you about the settlement instruction you want to release from CoSD hold.
3. Click on the *search* button.

- ⇒ A list containing the search results is displayed on the screen.
- ⇒ If the search retrieves only one settlement instruction, the *settlement instruction - details* screen is displayed directly. Proceed with step 6.
- 4. Select the settlement instruction you want to release from CoSD hold by clicking on an entry in the list.
- 5. Click on the *details* button.
  - ⇒ The *settlement instruction – details* screen is displayed.
- 6. Check the details of the settlement instruction and click on the *hold/release* button.
  - ⇒ The *hold/release instruction – new* screen is displayed.
- 7. Enter all mandatory information in the ‘General’ subframe.
- 8. Select the ‘CoSD Release’ check box and enter the reference of the relevant CoSD rule to be released in the ‘Hold/Release’ subframe.

| Current Hold Status                    | Hold Types                             | Release Types  |
|--|--|--|
| Party Hold Status<br>Released          | Party Hold<br><input type="checkbox"/> | Party Release<br><input type="checkbox"/>  |
| CSD Hold Status<br>Released            | CSD Hold<br><input type="checkbox"/>   | CSD Release<br><input type="checkbox"/>  |
| CSD Validation Hold Status<br>Released |  | CSD Validation Release<br><input type="checkbox"/>   |
| CoSD Hold Status<br>On Hold            |  | <input checked="" type="checkbox"/> CoSD Release<br>CoSD Rule Identification<br><input type="text"/> |



### Alternative

To set all fields to default value and blank out all optional fields, click on the *reset* button.

To cancel the process and return to the previous screen, click on the *cancel* button.

- 9. Click on the *submit* button.
- 10. Enter your PIN for digital signature purposes (NRO).
  - ➔ A new release instruction for CoSD hold has been created.

### 3.5.3.7 Release a Settlement Instruction from CSD Validation Hold

#### Context of Usage

This business scenario describes how to release a settlement instruction from CSD validation hold. This is necessary if you want to release a settlement instruction that was previously put on CSD validation hold in order to settle it. Settlement instructions put on CSD validation hold are not eligible for settlement until they are released.

Releasing a settlement instruction for CSD validation hold is one option for the creation of a new hold/release instruction for a settlement instruction.

Before you create a new release instruction for CSD validation hold, check whether the settlement instruction is eligible for the release from CSD validation hold. A settlement instruction is eligible to be released for a CSD validation hold if it is not cancelled, settled nor already released for CSD validation hold. You can check the status of your settlement instruction before creating the release instruction through the details screen as described in the business scenario view settlement instruction details [▶ 701].

This business scenario is not relevant for CB users.

#### Privileges

To carry out this business scenario, you need the following privileges:

- Settlement instruction query
- Settlement instruction current status query
- Settlement instruction status audit trail query
- Release CSD validation hold settlement instruction either on a securities account or on behalf of the CSD in T2S
- Send new instruction using a specific instructing party

#### Reference

Further information on screens involved can be found in the screen reference part:

- Settlement instructions – search/list* screen
- Settlement instruction – details* screen
- Hold/release instruction - new* screen [▶ 125]

#### Instructions

1. Go to the *settlement instructions – search/list* screen:  
Securities >> Settlement >> Settlement Instructions
2. Enter at least one general search criterion known to you about the settlement instruction you want to release from CSD validation hold.
3. Click on the *search* button.
  - ⇒ A list containing the search results is displayed on the screen.
  - ⇒ If the search retrieves only one settlement instruction, the *settlement instruction - details* screen is displayed directly. Proceed with step 6.

4. Select the settlement instruction you want to release CSD validation hold by clicking on an entry in the list.
5. Click on the *details* button.
  - ⇒ The *settlement instruction – details* screen is displayed.
6. Check the details of the settlement instruction and click on the *hold/release* button.
  - ⇒ The *hold/release instruction – new* screen is displayed.
7. Enter all mandatory information in the ‘General’ subframe.
8. Select the ‘CSD Validation Release’ check box in the ‘Hold/Release’ sub-frame.

The screenshot shows a form titled 'Hold/Release' with three columns: 'Current Hold Status', 'Hold Types', and 'Release Types'. Under 'Current Hold Status', there are four rows: 'Party Hold Status Released' (checkbox checked), 'CSD Hold Status Released' (checkbox checked), 'CSD Validation Hold Status On Hold' (checkbox checked), and 'CoSD Hold Status Released' (checkbox checked). Under 'Hold Types', there are two rows: 'Party Hold' (checkbox unchecked) and 'CSD Hold' (checkbox unchecked). Under 'Release Types', there are four rows: 'Party Release' (checkbox unchecked), 'CSD Release' (checkbox unchecked), 'CSD Validation Release' (checkbox unchecked, highlighted with a red box), and 'CoSD Release' (checkbox unchecked). At the bottom right, there is a 'CoSD Rule Identification' text input field.



### Alternative

To set all fields to default value and blank out all optional fields, click on the *reset* button.

To cancel the process and return to the previous screen, click on the *cancel* button.

9. Click on the *submit* button.
10. Enter your PIN for digital signature purposes (NRO).
  - ➔ A new release instruction for CSD validation hold has been created.

### 3.5.3.8 View Hold/Release Instruction Details

#### Context of Usage

This business scenario describes how to view the details of a hold/release instruction. Once the hold/release instruction is created in T2S it might be necessary for you to check its details to be aware of updates during the lifecycle of the hold/release instruction.

Viewing a hold/release instruction details is one option for the creation of a new hold/release instruction for a settlement instruction.

This business scenario is not relevant for CB users.

**Privileges**

To carry out this business scenario, you need the following privileges:

- Amendment instruction query for intra-position movements and settlement instructions
- Hold/release instruction audit trail list query
- Maintenance for intra-position movements and settlement instructions query
- Cancellation instruction query for intra-position movements and settlement instructions

**Reference**

Further information on screens involved can be found in the screen reference part:

- Maintenance securities instructions – search/list* screen [▶ 163]
- Hold/release instruction – details* screen [▶ 121]

**Instructions**

1. Go to *maintenance securities instructions – search/list* screen:  
Securities >> Settlement >> Maintenance Securities Instructions
2. Enter all search criteria known to you about the hold/release instruction for which you want to view the details.
3. Select the value 'Settlement Instruction' in the 'Instruction Type' field.

The screenshot shows the 'Search Criteria - Maintenance Securities Instructions' form. The 'Instruction Type' dropdown menu is highlighted with a red box, and 'Settlement Instruction' is selected. Other fields include Actor Reference, T2S Reference, Instructing Party BIC, Securities Account Number, Maintenance Instruction Type (set to 'Hold/Release Instruction'), Execution Status (set to 'All'), Entry Date, Cancellation Status (set to 'All'), and Pending Cancellation (set to 'All').

4. Select the value 'Hold/Release Instruction' in the 'Maintenance Instruction Type' field.

The screenshot shows the 'Search Criteria - Maintenance Securities Instructions' form. The 'Maintenance Instruction Type' dropdown menu is highlighted with a red box, and 'Hold/Release Instruction' is selected. The 'Instruction Type' dropdown is now set to 'Settlement Instruction'. Other fields are the same as in the previous screenshot.



**Alternatives**

To set all fields to default value and blank out all optional fields, click on the *re-set* button.

5. Click on the *search* button.
  - ⇒ A list containing the search results is displayed on the screen.
  - ⇒ If the search retrieves only one hold/release instruction, the *hold/release instruction – details* screen is displayed directly.
6. Select the hold/release instruction for which you want to view the details.
7. Click on the *details* button.
  - ⇒ The *hold/release instruction – details* screen is displayed.
- ➔ You have viewed the details of a hold/release instruction.

### 3.5.4 Creation of a New Cancellation Instruction for a Settlement Instruction

#### Overview

This business package describes the creation of a new cancellation instruction for a settlement instruction.

You can create a new cancellation instruction for a settlement instruction and afterwards you can check the information of the cancellation instruction in T2S.

To create a new cancellation instruction for a settlement instruction, carry out the following business scenarios in the predefined order.

#### Business Scenarios

1. Cancel a settlement instruction [▶ 727]
2. View cancellation instruction for a settlement instruction details [▶ 729]
3. View alleged cancellation instructions [▶ 730]

#### 3.5.4.1 Cancel a Settlement Instruction

#### Context of Usage

This business scenario describes how to create a new cancellation instruction for a settlement instruction. This is necessary if you want to cancel a settlement instruction so it is not further processed in T2S.

Cancelling a settlement instruction is mandatory for the creation of a cancellation instruction for a settlement instruction.

Before you cancel a settlement instruction, check whether the settlement instruction is neither already cancelled, settled nor on CoSD hold. You can check the status of your settlement instruction before creating the cancellation instruction through the details screen as described in the business scenario view settlement instruction details [▶ 701].

This business scenario is not relevant for CB users.

#### Privileges

To carry out this business scenario, you need the following privileges:

- Settlement instruction query
- Settlement instruction current status query

- Settlement instruction status audit trail query
- Cancel settlement instruction / settlement restriction on securities either on a securities account or on behalf of the CSD in T2S, on behalf of an external CSD or on behalf of an administering party
- Cancel non-modifiable instructions on behalf of the instructing party of the underlying settlement instruction
- Send new instruction using a specific instructing party

**Reference**

Further information on screens involved can be found in the screen reference part:

- Settlement instructions – search/list* screen
- Settlement instruction - details* screen
- Cancellation securities instruction - new* screen [▶ 116]

**Instructions**

1. Go to the *settlement instructions – search/list* screen:  
`Securities >> Settlement >> Settlement Instructions`
2. Enter at least one general search criterion known to you about the settlement instruction for which you want to view the details.
3. Click on the *search* button.
  - ⇒ A list containing the search results is displayed on the *settlement instructions – search/list* screen.
  - ⇒ If the search retrieves a single settlement instruction, the *settlement instruction - details* screen is displayed directly. Proceed with step 6.
4. Select the settlement instruction you want to cancel by clicking on an entry in the list.
5. Click on the *details* button.
  - ⇒ The *settlement instruction - details* screen is displayed.
6. Click on the *cancellation instruction* button.
  - ⇒ The *cancellation securities instruction - new* screen is displayed.
7. Enter all relevant information in the 'General' frame if needed.

**Alternative**

To set all fields to default value and blank out all optional fields, click on the *reset* button.

To cancel the process and return to the previous screen, click on the *cancel* button.

8. Click on the *submit* button.
9. Enter your PIN for digital signature purposes (NRO).



➔ A new cancellation instruction for a settlement instruction has been created.

### 3.5.4.2 View Cancellation Instruction for a Settlement Instruction Details

**Context of Usage**

This business scenario describes how to view the details of a cancellation instruction for a settlement instruction. Once the amendment instruction for a settlement instruction is created in T2S it might be necessary for you to check its details to be aware of updates during the lifecycle of the cancellation instruction.

Viewing a cancellation instruction for a settlement instruction details is optional for the creation of a new cancellation instruction for a settlement instruction.

This business scenario is not relevant for CB users.

**Privileges**

To carry out this business scenario, you need the following privileges:

- Amendment instruction query for intra-position movements and settlement instructions
- Maintenance for intra-position movements and settlement instructions query
- Cancellation instruction query for intra-position movements and settlement instructions
- Cancellation instruction for intra-position movement or settlement instruction audit trail details query

**Reference**

Further information on screens involved can be found in the screen reference part:

- Maintenance securities instructions – search/list* screen [▶ 163]
- Cancellation securities instruction - details* screen [▶ 112]

**Instructions**

1. Go to the *maintenance securities instructions – search/list* screen:  
Securities >> Settlement >> Maintenance Securities Instructions
2. Enter all search criteria known to you about the cancellation instruction for a settlement instruction for which you want to view the details.
3. Select the value 'Settlement Instruction' in the 'Instruction Type' field.

4. Select the value 'Cancellation Instruction' in the 'Maintenance Instruction Type' field.

The screenshot shows a search criteria form for 'Maintenance Securities Instructions'. The form includes several input fields and dropdown menus. The 'Maintenance Instruction Type' dropdown menu is highlighted with a red box, and 'Cancellation Instruction' is selected. Other fields include 'Actor Reference', 'T2S Reference', 'Instruction Type\*' (Settlement Instruction), 'Instructing Party Parent BIC', 'Instructing Party BIC', 'Securities Account Number', 'Entry Date', 'Execution Date', 'Cancellation Status' (All), and 'Pending Cancellation' (All).



### Alternative

To set all fields to default value and blank out all optional fields, click on the *reset* button.

5. Click on the *search* button.
  - ⇒ A list containing the search results is displayed on the screen.
  - ⇒ If the search retrieves only one cancellation instruction for a settlement instruction, the *cancellation securities instruction - details* screen is displayed directly.
6. Select the cancellation instruction for a settlement instruction for which you want to view the details.
7. Click on the *details* button.
  - ⇒ The *cancellation securities instruction - details* screen is displayed.
- ➔ You have viewed the details of a cancellation instruction for a settlement instruction.

### 3.5.4.3 View Alleged Cancellation Instructions

#### Context of Usage

This business scenario describes how to check if there is any settlement instruction requested for cancellation by the counterparty of the transaction in T2S. Once a settlement instruction is created in T2S it might be necessary for you to check if it has been requested for cancellation by the counterparty to create your own cancellation instruction in order to cancel the transaction in T2S. Once a settlement instruction is matched in T2S with its counterpart, bilateral cancellation by the two legs of the transaction is required.

Viewing alleged cancellation instructions is one option for the creation of a new cancellation instruction for a settlement instruction.

This business scenario is not relevant for CB users.

#### Privileges

To carry out this business scenario, you need the following privileges:

- Settlement instruction query

- Settlement instruction current status query
- Settlement instruction status audit trail query

**Reference**

Further information on screens involved can be found in the screen reference part:

- Settlement instructions– search/list* screen
- Settlement instruction - details* screen

**Instructions**

1. Go to the *settlement instructions– search/list* screen:  
Securities >> Settlement >> Settlement Instructions
2. Enter at least one general search criterion known to you about the settlement instruction for which you want to check if it has been requested for cancellation.
3. Click on the *search* button.
  - ⇒ The *settlement instructions – search/list* screen is displayed.
  - ⇒ If the search retrieves only one settlement instruction, the *settlement instruction - details* screen is displayed directly. Proceed with step 6.
4. Select the settlement instruction you want to check if it has been requested for cancellation by its counterpart by clicking on an entry in the list.

**Alternative**

To set all fields to default value and blank out all optional fields, click on the *reset* button.

To cancel the process and return to the previous screen, click on the *cancel* button.

5. Click on the *details* button.
  - ⇒ The *settlement instruction - details* screen is displayed.
6. Check if the 'Cancellation Requested' field in the 'Status Information' frame has the value 'Yes'. If the value is 'Yes', the settlement instruction has been requested for cancellation by the counterparty. In order to execute the cancellation another cancellation instruction needs to be received in T2S for this leg.

**Hint**

If you want to send a cancellation instruction to complete the cancellation request, continue with step 6 of the 'Cancel a Settlement Instruction [▶ 727]' business scenario.

- ➔ You have viewed your alleged cancellation instructions.

## 3.5.5 Monitoring of the Lifecycle of a Settlement Instruction

### Overview

This business package describes the monitoring of the lifecycle of a settlement instruction.

You can check the status updates during the lifecycle of a settlement instruction once it has been created in T2S.

To monitor the lifecycle of a settlement instruction, carry out the following business scenarios.

### Business Scenarios

- View settlement instruction status history [▶ 732]
- View SF1/SF2 timestamps of Settlement Instructions in case of Insolvency situation [▶ 733]

### 3.5.5.1 View Settlement Instruction Status History

### Context of Usage

This business scenario describes how to view the status history of a settlement instruction.

Once a settlement instruction is created in T2S it might be necessary for you to check its status history to be aware of its status changes during the lifecycle of the settlement instruction.

Viewing settlement instruction status history is mandatory for the monitoring of the lifecycle of a settlement instruction

This business scenario is not relevant for CB users.

### Privileges

To carry out this business scenario, you need the following privileges:

- Settlement instruction query
- Settlement instruction current status query
- Settlement instruction status audit trail query
- Settlement instruction audit trail query

### Reference

Further information on screens involved can be found in the screen reference part:

- Settlement instructions – search/list* screen
- Settlement instruction – details* screen
- Status history – details* screen [▶ 266]

### Instructions

1. Go to the *settlement instructions – search/list* screen:  
`Securities >> Settlement >> Settlement Instructions`
2. Enter at least one general search criterion known to you about the settlement instruction for which you want to view the details.
3. Click on the *search* button.

- ⇒ A list containing the search results is displayed on the screen.
- ⇒ If the search retrieves only one settlement instruction, the *settlement instruction – details* screen is displayed directly. Proceed with step 6.



### Alternative

To set all fields to default value and blank out all optional fields, click on the *reset* button.

4. Select the settlement instruction for which you want to view the details.
  5. Click on the *details* button.
    - ⇒ The *settlement instruction – details* screen is displayed.
  6. Click on the *status history* button.
    - ⇒ The *status history - details* screen is displayed.
- ➔ You have viewed the settlement instruction status history.

## 3.5.5.2 View SF1/SF2 timestamps of Settlement Instructions in case of Insolvency situation

### Context of Usage

This business scenario describes how to retrieve the SF1/SF2 timestamps of settlement instructions in case of insolvency situation.

Once a settlement instruction is created in T2S it might be necessary for you to retrieve the SF1/SF2 timestamps for insolvency proceedings during the lifecycle of the settlement instruction.

This business scenario is not relevant for CB users.

### Privileges

To carry out this business scenario, you need the following privilege:

- Settlement instruction matched and accepted status query privilege

### Reference

Further information on screens involved can be found in the screen reference part:

- Insolvency procedure settlement instructions – search/list* screen [▶ 269]

### Instructions

1. Go to the *insolvency procedure settlement instructions – search/list* screen:  
Securities >> Settlement >> Insolvency procedure Settlement Instructions
2. Enter at least one insolvent object criterion known to you to retrieve SF1 and SF2 timestamps of settlement instructions under insolvency procedures.
3. Click on the *search* button.
  - ⇒ A list containing the search results is displayed on the screen.

- ➔ You have retrieved SF1/SF2 timestamps of Settlement Instructions in case of Insolvency situation



### Alternative

To set all fields to default value and blank out all optional fields, click on the *re-set* button.

## 3.5.6 View the list of links data preventing settlement of a settlement instruction

### Context of Usage

This business scenario describes how to view the list of data preventing settlement of a selected settlement instruction.

When a linked settlement instruction is unsettled, it might be useful for you to check the list of the settlement instructions or settlement restrictions preventing its settlement with the associated constraints.

This business scenario is not relevant for the following cases:

- Settled, cancelled and not matched instructions
- Settlement instructions with an intended settlement date in the future

### Privileges

To carry out this business scenario, you need the following privileges:

- Settlement instruction query
- Settlement instruction current status query

### Reference

Further information on screens involved can be found in the screen reference part:

- Settlement instructions – search/list
- Settlement instruction – details
- Links preventing settlement – list

### Instructions

1. Go to the settlement instructions – search/list screen:  
Securities >> Settlement >> Settlement Instructions
2. Enter at least one general search criterion known to you about the settlement instruction for which you want to view the links data preventing its settlement.
3. Click on the search button.
  - A list containing the search results is displayed on the screen
  - If the search retrieves only one settlement instruction, the settlement instruction – details screen is displayed directly. Proceed with step 6.

4. Select the settlement instruction for which you want to view the links data preventing settlement by clicking on an entry in the list.
5. Click on the details button.
  - The settlement instructions – details screen is displayed.
6. Check the details of the settlement instruction and click on the links button.
  - The links preventing settlement – list screen is displayed.
  - You have viewed the list of the settlement instructions and/or settlement instructions preventing the settlement of the selected settlement instruction with the associated constraints.

### 3.5.7 Monitoring of Penalties

#### Overview

This business package describes the monitoring of the penalties computed by T2S for failing settlement instructions.

You can search for penalties computed by T2S, view the individual details of a penalty, modify existing penalties, view the list of penalties related to a settlement instruction and check the monthly net amounts of the penalties computed for the business days of a previous month.

To monitor penalties, the following business scenarios are available.

#### Business Scenarios

- View the individual penalty details
- Modification of existing penalties
- View list of penalties
- View the monthly net amount of penalties

#### 3.5.7.1 View the Individual Penalty Details

#### Context of Usage

This business scenario describes how to retrieve the details of a penalty associated to a settlement instruction.

Once a penalty is computed for a given settlement instruction it might be necessary for you to retrieve its details.

This function will not be available either during the Maintenance Window or during the processing of penalties, i.e. between the Events “PMSS” (Penalty Mechanism- Stop Screens and penalty modification requests) and “PMRR” (Penalty Mechanism- Restart GUI and Restart processing penalty modification requests).

This business scenario is only available for CSD authorized users and T2S Operator user.

#### Privileges

To carry out this business scenario, you need the following privileges:

- Penalty Details Query Privilege

- Settlement Instruction Audit Trail Query

**Reference**

Further information on screens involved can be found in the screen reference part:

- Penalty – search/list screen
- Penalty – details screen
- Settlement instruction – details screen

**Instructions**

1. Go to the Penalty – search/list screen:  
Securities >> Settlement >> Daily Penalties
2. Enter a valid combination of search criteria. For this, you can either choose:
  - ⇒ To perform the query with a reference. For this you should specify at least one or a valid combination of the search criteria.  
This query cannot use the Additional Search Criteria for Penalty Query by ISIN Code Criteria, by T2S Party Criteria and System Entity Criteria.  
This query cannot be combined with any other query.
  - ⇒ To perform the query by ISIN Code Criteria and/or by T2S Party Criteria.  
These two queries can be combined or used separately.  
If combined together, the parameters will be combined through AND logic, and the minimum search criteria of at least one of the two queries shall be respected.  
At least the minimum search criteria shall be specified. Additional search criteria can be used to limit the query results.
  - ⇒ To perform a System Entity Criteria query. For this you should at least enter the minimum search criteria.  
Additional search criteria can be used to limit the query results.  
This query cannot be combined with any other query.
3. Click on the search button.
  - ⇒ If the search retrieves more than one penalty a list containing the search results is displayed on the screen.
  - ⇒ If the search retrieves only one penalty, the penalty – details screen is displayed directly.
  - ⇒ You have viewed the individual penalty details.

**Alternative**

---

4. Select the penalty for which you want to view the details by clicking on the entry in the list.
5. Click on the details button.



- ⇒ The penalty – details screen is displayed.
- ⇒ You have viewed the individual penalty details.



---

### Alternative

---

6. In the Settlement Instruction – details screen >> Click on the associated penalties button.
    - ⇒ If more than one penalty is retrieved by T2S, the penalty – search/list screen will be displayed.
    - ⇒ If only one penalty is retrieved by T2S, the penalty – details screen will be displayed.
- ➔ You have viewed the individual penalty details



---

### Alternative

---

To set all fields to default value and blank out all optional fields, click on the reset button

---

## 3.5.7.2 Modification of existing penalties

### Context of Usage

This business scenario describes how to remove, re-include, re-allocate or switch an existing penalty computed for a settlement instruction.

CSDs and T2S Operator will be able to request the removal of a penalty only when the penalty was imposed to one of its participants or to itself. To cater for mistakes in the removal of penalties, T2S allows CSDs and T2S Operator to re-include a penalty that the CSD has previously removed.

Also, when an already matched settlement instruction is sent late to T2S, CSDs and T2S Operator are able to re-allocate the penalty from the Instructing Party, initially assigned as failing and non-failing party, to the delivering party and the receiving party of the instruction. Finally, if T2S calculates and assigns the penalty to a party which, due to external conditions outside T2S, should not be the party penalised but entitled to receive the penalty, CSDs and T2S Operator will be able to switch the failing and non-failing party of the penalty.

You may remove, re-include, re-allocate or switch existing penalties anytime of the day except during the Maintenance Window or during the processing of penalties, i.e. between the Events “PMSS” (Penalty Mechanism- Stop Screens and penalty modification requests) and “PMRR” (Penalty Mechanism- Restart GUI and Restart processing penalty modification requests).

These functionalities are only available during the appeal period of the penalty.

Additionally:

- If the status of the penalty is not 'Active', the remove function will not be available.
- If the status of the penalty is not 'Removed', the re-include function will not be available.
- If either the status of the penalty is not 'Active', or the penalty is a SEFP, or if it is a LMFP but the underlying instruction was not sent as already matched to T2S, or the LMFP has already been re-allocated before, the re-allocate function will not be available.
- If the status of the penalty is not 'Active', the switch function will not be available.
- This business scenario is only available for CSD authorized users and T2S Operator user.

### Privileges

To carry out this business scenario, you need the following privileges:

- Penalty Details Query Privilege
- Settlement Instruction Audit Trail Query
- Modification of Penalties Privilege

### References

Further information on screens involved can be found in the screen reference part:

- Penalty – details screen
- Penalty removal screen
- Penalty re-inclusion screen
- Penalty re-allocacion screen
- Penalty switch screen

### Instructions

1. Go to the Penalty – search/list screen:  
Securities >> Settlement >> Daily Penalties
2. Enter a valid combination of search criteria. For this, you can either choose:
  - ⇒ To perform the query with a reference. For this you should specify at least one or a valid combination of the search criteria.  
This query cannot use the Additional Search Criteria for Penalty Query by ISIN Code Criteria, by T2S Party Criteria and System Entity Criteria.  
This query cannot be combined with any other query.
  - ⇒ To perform the query by ISIN Code Criteria and/or by T2S Party Criteria.  
These two queries can be combined or used separately.  
If combined together, the parameters will be combined through AND logic, and the minimum search criteria of at least one of the two queries shall be

respected.

At least the minimum search criteria shall be specified. Additional search criteria can be used to limit the query results.

- ⇒ To perform a System Entity Criteria query. For this you should at least enter the minimum search criteria.

Additional search criteria can be used to limit the query results.

This query cannot be combined with any other query.

3. Click on the search button.

- ⇒ If the search retrieves more than one penalty a list containing the search results is displayed on the screen.
- ⇒ If the search retrieves only one penalty, the penalty – details screen is displayed directly.



---

### Alternative

---

4. Select the penalty for which you want to view the details by clicking on the entry in the list.

5. Click on the details button.

- ⇒ The penalty – details screen is displayed.

6. To remove a penalty:

- ⇒ Click on the “Remove” button. This function will not be available if the status of the penalty is not ‘Active’.
- ⇒ Penalty removal screen will pop up with the relevant information to create a Removal Request based on the Penalty of the screen.
- ⇒ Select the reason code, insert the Description text if the reason selected is OTHR, and click on the Submit button.
- ⇒ Enter your PIN for digital signature purposes (NRO).

➔ You have removed the penalty.

7. To re-include a penalty:

- ⇒ Click on the “Re-include” button. This function will not be available if the status of the penalty is not ‘Removed’.
- ⇒ A confirmation prompt will pop-up. Hence, the action is triggered (i.e. the Re-inclusion Request is sent) and the Penalty - details screen is displayed again updated (i.e. Penalty with new status ACTV, (Active), new Reason Code UPDT (Updated) and description (if applies), the penalty amount

and Calculation details before the penalty was removed and the To be re-calculated flag set to YES) if the Re-inclusion Request is confirmed and executed (the action was triggered in Two-eyes).

- ⇒ Click on the Yes button.
  - ⇒ Enter your PIN for digital signature purposes (NRO).
  - ➔ You have re-included the penalty.
8. To re-allocate a penalty:
- ⇒ Click on the “Re-allocate” button. This function will not be available if either the status of the penalty is not ‘Active’, if the penalty is a SEFP or a LMFP but the underlying instruction was not sent as already matched to T2S, or if the LMFP has already been re-allocated before.
  - ⇒ Penalty re-allocation screen will pop-up with the relevant information to create a Re-allocation Request based on the Penalty of the screen.
  - ⇒ Select the New failing party and, only in case the two BIC’s retrieved for the New failing Party BIC are the same, additionally select the T2S Reference of the Failing Settlement Instruction. Finally, click on the Submit button.
  - ⇒ Enter your PIN for digital signature purposes (NRO).
- ➔ You have re-allocated the penalty
9. To switch a penalty:
- ⇒ Click on the “Switch” button. This function will not be available if the status of the penalty is not ‘Active’.
  - ⇒ Penalty switch screen will pop-up with the relevant information to create a Switch Request based on the Penalty of the screen.
  - ⇒ Insert the Description text and click on the Submit button.
  - ⇒ Enter your PIN for digital signature purposes (NRO).
- ➔ You have switched the penalty.



---

### Alternative

- 
10. In the Settlement Instruction – details screen >> Click on the associated penalties button.
- ⇒ If more than one penalty is retrieved by T2S, the penalty – search/list screen will be displayed.
  - ⇒ If only one penalty is retrieved by T2S, the penalty – details screen will be displayed.
2. To remove a penalty:

- ⇒ Click on the “Remove” button. This function will not be available if the status of the penalty is not ‘Active’.
  - ⇒ Penalty removal screen will pop up with the relevant information to create a Removal Request based on the Penalty of the screen.
  - ⇒ Select the reason code, insert the Description text if reason selected is OTHR, and click on the Submit button.
  - ⇒ Enter your PIN for digital signature purposes (NRO).
  - ➔ You have removed the penalty.
12. To re-include a penalty:
- ⇒ Click on the “Re-include” button. This function will not be available if the status of the penalty is not ‘Removed’.
  - ⇒ A confirmation prompt will pop-up. Hence, the action is triggered (i.e. the Re-inclusion Request is sent) and the Penalty - details screen is displayed again updated (i.e. Penalty with new status ACTV, (Active), new Reason Code UPDT (Updated) and description (if applies), the penalty amount and Calculation details before the penalty was removed and the flag To be recalculated set to YES) if the Re-inclusion Request is confirmed and executed (the action was triggered in Two-eyes).
  - ⇒ Click on the Yes button.
  - ⇒ Enter your PIN for digital signature purposes (NRO).
  - ➔ You have re-included the penalty.
13. To re-allocate a penalty:
- ⇒ Click on the “Re-allocate” button. This function will not be available if either the status of the penalty is not ‘Active’, if the penalty is a SEFP or a LMFP but the underlying instruction was not sent as already matched to T2S, or if the LMFP has been re-allocated before.
  - ⇒ Penalty re-allocation screen will pop-up with the relevant information to create a Re-allocation Request based on the Penalty of the screen.
  - ⇒ Select the New failing party and only in case the two BIC’s retrieved for the New failing Party BIC are the same, additionally select the T2S Reference of Failing Settlement Instruction. Finally, click on the Submit button.
  - ⇒ Enter your PIN for digital signature purposes (NRO).
  - ➔ You have re-allocated the penalty.
14. To switch a penalty:
- ⇒ Click on the “Switch” button. This function will not be available if the status of the penalty is not ‘Active’.
  - ⇒ Penalty switch screen will pop-up with the relevant information to create a Switch Request based on the Penalty of the screen.

- ⇒ Insert the Description text and click on the Submit button.
- ⇒ Enter your PIN for digital signature purposes (NRO).
- ➔ You have switched the penalty.

### 3.5.7.3 View List of Penalties

#### Context of Usage

This business scenario describes how to retrieve the list of penalties associated to a settlement instruction.

Once a given settlement instruction is subject to the calculation of penalties it might be necessary for you to retrieve them.

This function will not be available either during the Maintenance Window or during the processing of penalties, i.e. between the Events “PMSS” (Penalty Mechanism- Stop Screens and penalty modification requests) and “PMRR” (Penalty Mechanism- Restart GUI and Restart processing penalty modification requests).

This business scenario is only available for CSD authorized users and T2S Operator user.

#### Privileges

To carry out this business scenario, you need the following privileges:

- Penalty List Query Privilege
- Settlement Instruction Audit Trail Query

#### Reference

Further information on screens involved can be found in the screen reference part:

- Penalty – search/list screen
- Settlement instruction – details screen

#### Instructions

1. Go to the Penalty – search/list screen:  
Securities >> Settlement >> Daily Penalties
2. Enter a valid combination of search criteria. For this, you can either choose:
  - ⇒ To perform the query with a reference. For this you should specify at least one or a valid combination of the search criteria.  
This query cannot use the Additional Search Criteria for Penalty Query by ISIN Code Criteria, by T2S Party Criteria and System Entity Criteria.  
This query cannot be combined with any other query.
  - ⇒ To perform the query by ISIN Code Criteria and/or by T2S Party Criteria.  
These two queries can be combined or used separately.  
If combined together, the parameters will be combined through AND logic, and the minimum search criteria of at least one of the two queries shall be respected.  
At least the minimum search criteria shall be specified. Additional search criteria can be used to limit the query results.

- ⇒ To perform a System Entity Criteria query. For this you should at least enter the minimum search criteria.  
Additional search criteria can be used to limit the query results.  
This query cannot be combined with any other query.
- 3. Click on the search button.
  - ⇒ If the search retrieves more than one penalty a list containing the search results is displayed on the screen.
  - ⇒ You have viewed the list of penalties.
  - ⇒ If the search retrieves only one penalty, the penalty – details screen is displayed directly.



---

**Alternative**

- 4. In the Settlement Instruction – details screen >> Click on the associated penalties button.
  - ⇒ If more than one penalty is retrieved by T2S, the penalty – search/list screen will be displayed.
  - ⇒ You have viewed the list of penalties.
  - ⇒ If only one penalty is retrieved by T2S, the penalty – details screen will be displayed.



---

**Alternative**

To set all fields to default value and blank out all optional fields, click on the reset button.

---

### 3.5.7.4 View monthly aggregated net amounts of penalties

**Context of Usage**

This business scenario describes how to retrieve the monthly aggregated net amounts of the penalties computed by T2S for the business days of a previous month, for a given T2S Party and counterparty(ies) and per relevant currency.

Once the appeal period of the penalties of a given month has ended, you may need to retrieve the monthly net amounts for all the penalties computed by T2S to ease the penalty collection and distribution process.

This amount shall provide, per currency and party, the bilateral net amounts against each of the counterparties of the penalties computed, and will be equal to:

- The sum of all penalties of the relevant/previous month in the relevant currency that this party is entitled to receive (reported as credit) from the same counterparty (i.e. to be paid by this counterparty);

Minus

- The sum of all penalties of the relevant/previous month in the relevant currency, that were imposed to this party (reported as debit), and to be paid to a given counterparty.

The monthly net amounts of a particular month will be available only once T2S has produced the Monthly Aggregated Amounts report of that month.

Only the monthly net amounts for the past 3 months will be available.

This function will not be available during the Maintenance Window.

This business scenario is only available for CSD authorized users and T2S Operator user.

### Privileges

To carry out this business scenario, you need the following privileges:

- Penalty Details Query Privilege
- Monthly Net Amount Query Privilege

### Reference

Further information on screens involved can be found in the screen reference part:

- Monthly Net Penalty Amounts – search/list screen

### Instructions

1. Go to the Penalty – search/list screen:  
Securities >> Settlement >> Monthly Penalties
  2. Enter at least the minimum search criteria.  
Depending on the search criteria specified, one or more results can be displayed (i.e. depending on the currency or on the counterparty).
  3. Click on the search button.
    - ⇒ If the search retrieves more than one monthly net amount, a list containing the search results is displayed on the screen.
    - ⇒ If the search retrieves only one monthly net amount, it will be displayed in the same format used by the list screen.
- ➔ You have viewed the monthly net amount.



## 3.6 Settlement Restrictions

### 3.6.1 Creation of a New Settlement Restriction on Securities

#### Overview

This business package describes the creation of a new settlement restriction on securities.

You can create a new settlement restriction on securities either by entering all the necessary information or by copying it from an already existing settlement restriction on securities. Once the settlement restriction on securities has been created, you can also check its lifecycle in T2S.

To create a new settlement restriction on securities, carry out the following business scenarios in the predefined order and choose the business scenario relevant to you whenever options are given.

#### Business Scenarios

1. Create a new settlement restriction on securities
  - Enter a settlement restriction on securities [▶ 745]
  - Copy a settlement restriction on securities [▶ 747]
2. View settlement restriction on securities details [▶ 750]

#### 3.6.1.1 Enter a Settlement Restriction on Securities

#### Context of Usage

This business scenario describes how to create a new settlement restriction on securities. You can create a new settlement restriction on securities (intra-position movement) to move securities into a specific securities position of a securities account and make them available for a specific purpose (blocking, reservation or earmarking). Optionally, you can create your settlement restriction on securities including a link to another instruction or to a pool of instructions.

Entering a settlement restriction on securities is one option for the creation of a settlement restriction on securities.

This business scenario is not relevant for CB users.

#### Privileges

To carry out this business scenario, you need the following privileges:

- Send new settlement instruction/new settlement restriction on securities either on a securities account or on behalf of an external CSD
- Unblock CoSD securities blocking related to cancelled CoSD settlement instructions on behalf of the relevant CSD in T2S
- Link to an instruction/pool reference belonging to a specific party
- Intra-position movements query
- Send new instruction using a specific instructing party

**Reference** Further information on screens involved can be found in the screen reference part:

- Intra-position movements– search/list* screen [▶ 136]
- Intra-position movement – new* screen [▶ 150]

**Instructions**

1. Go to the *intra-position movements– search/list* screen:  
Securities >> Settlement >> Intra-Position Movements
2. Click on the *new* button.  
⇒ The *intra-position movement - new* screen is displayed.
3. Enter all mandatory information about the settlement restriction you want to create in the 'Intra-Position Movement' frame.
4. Optionally, you can enter additional information about the settlement restriction on securities into the optional fields.
5. To link your settlement restriction on securities to another instruction, click on the *add row* icon to add a new link

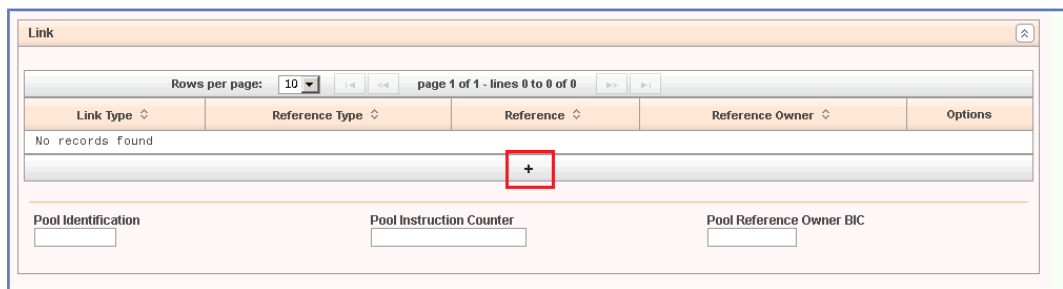

6. Select and add all the requested information to identify the instruction you want your settlement restriction on securities to be linked with. Once all the information is introduced click on the *submit changes* icon in the 'Options' column.

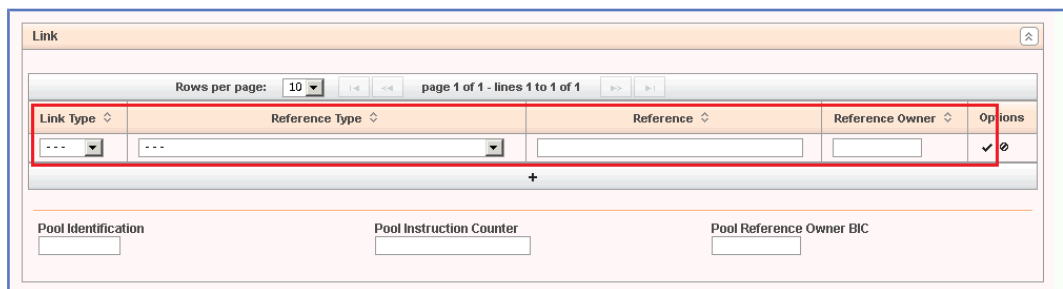

⇒ The link has been added to the list.

7. If you want to add your settlement restriction on securities to a pool, enter the 'Pool Identification' field, 'Pool Instruction Counter' field and the 'Pool Reference Owner BIC' field instead.

The screenshot shows a web form titled "Link". At the top, it displays "Rows per page: 10" and "page 1 of 1 - lines 0 to 0 of 0". Below this is a table with the following columns: "Link Type", "Reference Type", "Reference", "Reference Owner", and "Options". The table currently shows "No records found" and a "+" sign in the center. Below the table are three input fields: "Pool Identification", "Pool Instruction Counter", and "Pool Reference Owner BIC". A red rectangular box highlights these three input fields.



### Repetition

To add more links, repeat steps 5 to 6.

- To remove a link from the list of links to be added to the settlement restriction on securities, click on the *Delete Row* icon in the 'Options' column.

⇒ The link has been deleted from the list of links



### Alternatives

To set all fields to default value and blank out all optional fields, click on the *reset* button.

To cancel the process and return to the previous screen, click on the *cancel* button.

- Click on the *submit* button.
  - Enter your PIN for digital signature purposes (NRO).
- ➔ The new settlement restriction on securities has been created.

## 3.6.1.2 Copy a Settlement Restriction on Securities

### Context of Usage

This business scenario describes how to create a new settlement restriction on securities. You can create a new settlement restriction on securities (intra-position movement) to move securities into a specific securities position of a securities account, and make them available for a specific purpose.

Copying a settlement restriction on securities is 1 option for the creation of a settlement restriction on securities.

It allows you to use an already existing settlement restriction on securities as a template and modify the content as you need.

You can also create your settlement restriction on securities including a link to another instruction or to a pool of instructions.

This business scenario is not relevant for CB users.

### Privileges

To carry out this business scenario, you need the following privileges:

- Send new settlement restriction on securities either on a securities account or on behalf of an external CSD

- Unblock CoSD securities blocking related to cancelled CoSD settlement instructions on behalf of the relevant CSD in T2S
- Link to an instruction/pool reference belonging to a specific party
- Intra-position movements query
- Send new instruction using a specific instructing party

**Reference**

Further information on screens involved can be found in the screen reference part:

- *Intra-position movements – search/list* screen [▶ 136]
- *Intra-position movement - details* screen
- *Intra-position movement - new* screen [▶ 150]

**Instructions**

1. Go to the *intra-position movements – search/list* screen:  
Securities >> Settlement >> Intra-Position Movements
2. Enter all search criteria known to you about the settlement restriction on securities you want to copy.
3. Click on the *search* button.
  - ⇒ A list containing the search results is displayed on the screen.
  - ⇒ If the search retrieves only one settlement restriction on securities, the *intra position movement - details* screen is displayed directly. Proceed with step 6.
4. Select the settlement restriction on securities you want to copy by clicking on an entry in the list.
5. Click on the *details* button.
  - ⇒ The *intra-position movement - details* screen is displayed.
6. Click on the *copy* button.
  - ⇒ The *intra-position movement - new* screen is displayed taking by default the following fields from the original settlement restriction: instructing party BIC, instructing party parent BIC, intended settlement date, corporate action event id, priority, movement type, securities account securities, ISIN, quantity, balance from, balance to and restriction reference.
7. Check if all the default values that have been copied from the settlement restriction on securities are right for the new settlement restriction on securities or edit them if needed.
8. You can enter additional information about the settlement restriction on securities into the optional fields.

- To link your settlement restriction on securities to another instruction, click on the *add row* icon to add a new link.

- Select and add all the requested information to identify the instruction you want your settlement restriction on securities to be linked with.

- Click on the *submit changes* icon in the 'Options' column.

⇒ The link has been added to the list.

- If you want to add your settlement restriction on securities to a pool, enter the 'Pool Identification' field, 'Pool Instruction Counter' field and the 'Pool Reference Owner BIC' field instead.



### Repetition

To add more links, repeat steps 9 to 10.

- To remove a link from the list of links to be added to the settlement restriction on securities, click on the *delete row* icon in the 'Options' column.

⇒ The link has been deleted from the list of links.



### Alternatives

To set all fields to default value and blank out all optional fields, click on the *reset* button.

To cancel the process and return to the previous screen, click on the *cancel* button.

14. Click on the *submit* button.

15. Enter your PIN for digital signature purposes (NRO).

- ➔ The new settlement restriction on securities has been created based on a copied settlement restriction on securities.

## 3.6.1.3 View Settlement Restriction on Securities Details

### Context of Usage

This business scenario describes how to view the details of a settlement restriction on securities.

Once a settlement restriction on securities is created in T2S it might be necessary for you to check its details to be aware of updates during the lifecycle of the settlement restriction.

Viewing settlement restriction on securities details is optional for the creation of a new settlement restriction on securities.

This business scenario is not relevant for CB users.

### Privileges

To carry out this business scenario, you need the following privilege:

- Intra-position movements query

### Reference

Further information on screens involved can be found in the screen reference part:

- Intra-position movements – search/list* screen [▶ 136]
- Intra-position movement – details* screen

### Instructions

1. Go to the *intra-position movements – search/list* screen:  
`Securities >> Settlement >> Intra-Position Movements`
2. Enter all search criteria known to you about the settlement restriction on securities for which you want to view the details.
3. Click on the *search* button.
  - ⇒ A list containing the search results is displayed on the screen.
  - ⇒ If the search retrieves only one settlement restriction on securities, the *intra-position movement – details* screen is displayed directly.



### Alternative

To set all fields to default value and blank out all optional fields, click on the *re-set* button.

4. Select the settlement restriction on securities for which you want to view the details by clicking on the entry in the list.
5. Click on the *details* button.
  - ➔ The *intra-position movement – details* screen is displayed and you have viewed the settlement restriction on securities details.

## 3.6.2 Creation of a New Settlement Restriction on Cash

### Overview

This business package describes the creation of a new settlement restriction on cash. You can create a new settlement restriction on cash either by entering all the necessary information or by copying it from an already existing settlement restriction on cash. Once the settlement restriction on cash has been created, you can also check its lifecycle in T2S.

To create a new settlement restriction on cash, carry out the following business scenarios in the predefined order and choose the business scenario relevant to you whenever options are given.

### Business Scenarios

1. Create a new settlement restriction on cash
  - Enter a settlement restriction on cash [▶ 751]
  - Copy a settlement restriction on cash [▶ 753]
2. View settlement restriction on cash details [▶ 756]

### 3.6.2.1 Enter a Settlement Restriction on Cash

### Context of Usage

This business scenario describes how to create a new settlement restriction on cash (intra-balance movement). You can block or reserve cash sub-balances on a T2S dedicated cash account. You can also create a new settlement restriction on cash to increase or decrease the cash in an existing restricted cash sub-balance. Optionally, you can include a restriction reference, a link to another instruction or to a pool of instructions.

Entering a new settlement restriction on cash is one option for the creation of a settlement restriction on cash.

Before you create a new settlement restriction on cash to increase or decrease an existing cash sub-balance, check if the restricted balance has been created, and if the restriction reference exists.

This business scenario is not relevant for CSD users.

### Privileges

To carry out this business scenario, you need the following privileges:

- Send new settlement restriction on cash on a dedicated cash account
- Unblock CoSD cash blocking related to cancelled CoSD settlement instructions on behalf of the relevant CSD in T2S
- Link to an instruction/pool reference belonging to a specific party
- Intra-balance movements query
- Send new instruction using a specific instructing party

**Reference**

Further information on screens involved can be found in the screen reference part:

- Intra-balance movements – search/list* screen [▶ 422]
- Intra-balance movement - new* screen [▶ 436]

**Instructions**

1. Go to the *intra-balance movements – search/list* screen:  
Cash >> Settlement >> Intra-balance movements
2. Click on the *new* button.  
⇒ The *intra-balance movement - new* screen is displayed.
3. Enter all mandatory information in the ‘Intra-Balance Movement’ frame.
4. Optionally, you can enter additional information about the settlement restriction on cash into the optional fields.
5. To link your settlement restriction on cash to another instruction, click on the *add row* icon to add a new link.

6. Select and add all the requested information to identify the instruction you want your settlement restriction on cash to be linked to. Once all the information are introduced click on the *submit changes* icon in the ‘Options’ column.

- ⇒ The link has been added to the list.



- If you want to add your settlement restriction on securities to a pool, enter the 'Pool Identification' field, 'Pool Instruction Counter' field and the 'Pool Reference Owner BIC' field instead.

| Link Type                  | Reference Type           | Reference                | Reference Owner | Options |
|----------------------------|--------------------------|--------------------------|-----------------|---------|
| No records found           |                          |                          |                 |         |
| +                          |                          |                          |                 |         |
| Pool Instruction Reference | Pool Instruction Counter | Pool Reference Owner BIC |                 |         |



### Repetition

To add more links, repeat steps 5 to 6.

- To remove a link from the list of links to be added to the settlement restriction on cash, click on the *delete row* icon in the 'Options' column.

⇒ The link has been deleted from the list of links



### Alternatives

To set all fields to default value and blank out all optional fields, click on the *reset* button.

To cancel the process and return to the previous screen, click on the *cancel* button.

- Click on the *submit* button.
- Enter your PIN for digital signature purposes (NRO).  
➔ The new settlement restriction on cash has been created.

## 3.6.2.2 Copy a Settlement Restriction on Cash

### Context of Usage

This business scenario describes how to create a new settlement restriction on cash (intra-balance movement) based on an already existing settlement restriction on cash. You can block or reserve cash sub-balances on a T2S dedicated cash account. You can also create a new settlement restriction on cash to increase or decrease the cash in an existing restricted cash sub-balance. Optionally, you can include a restriction reference, a link to another instruction or to a pool of instructions.

This business scenario is relevant for all situations where you want to create a new settlement restriction on cash based on the information of an already existing one in T2S.

Copying an existing settlement restriction on cash is one option for the creation of a settlement restriction on cash.

Before you create a new settlement restriction on cash to increase or decrease an existing cash sub-balance, check whether if the restricted balance has been created and if the restriction reference exists.

This business scenario is not relevant for CSD users.

### Privileges

To carry out this business scenario, you need the following privileges:

- Send new settlement restriction on cash on a dedicated cash account
- Unblock CoSD cash blocking related to cancelled CoSD settlement instructions on behalf of the relevant CSD in T2S
- Link to an instruction/pool reference belonging to a specific party
- Intra-balance movements query
- Intra-balance movement audit trail list query
- Send new instruction using a specific instructing party

### Reference

Further information on screens involved can be found in the screen reference part:

- Intra-balance movements – search/list* screen [▶ 422]
- Intra-balance movement - details* screen
- Intra-balance movement - new* screen [▶ 436]

### Instructions

1. Go to the *intra-balance movements – search/list* screen:  
Cash >> Settlement >> Intra-Balance Movements
2. Enter all search criteria known to you about the settlement restriction on cash you want to copy.
3. Click on the *search* button.
  - ⇒ A list containing the search results is displayed on the screen.
  - ⇒ If the search retrieves only one settlement restriction on cash, the *intra-balance movement - details* screen is displayed directly. Proceed with step 6.
4. Select the settlement restriction on cash you want to copy by clicking on an entry in the list.
5. Click on the *details* button.
  - ⇒ The *intra-balance movement - details* screen is displayed.
6. Click on the *copy* button.
  - ⇒ The *intra-balance movement - new* screen is displayed taking by default values of the following fields from the original settlement restriction on cash: instructing party BIC, instructing party parent BIC, actor reference, intended settlement date, dedicated cash account, amount, balance from and balance to, restriction reference.

7. Check if the default values are correct or edit them if needed.
8. You can enter additional information about the settlement restriction on cash into the optional fields.
9. To link your settlement restriction on cash to another instruction, click on the *add row* icon to add a new link.

10. Select and add all the requested information (reference type, reference, reference owner) to identify the instruction you want your settlement restriction on cash to be linked with.
11. Click on the *submit changes* icon in the 'Options' column.

⇒ The link has been added to the list.

12. If you want to add your settlement restriction on securities to a pool, enter the 'Pool Identification' field, 'Pool Instruction Counter' field and the 'Pool Reference Owner BIC' field instead.



### Repetition

To add more links, repeat steps 9 to 10.

13. To remove a link from the list of links to be added to the settlement restriction on cash, click on the *delete row* icon in the 'Options' column.

⇒ The link has been deleted from the list of links.



### Alternatives

To set all fields to default value and blank out all optional fields, click on the *reset* button.

To cancel the process and return to the previous screen, click on the *cancel* button.

14. Click on the *submit* button.

15. Enter your PIN for digital signature purposes (NRO).

- ➔ The new settlement restriction on cash has been created based on a copied settlement restriction on cash.

## 3.6.2.3 View Settlement Restriction on Cash Details

### Context of Usage

This business scenario describes how to view the details of a settlement restriction on cash. Once a settlement restriction on cash is created in T2S it might be necessary for you to check its details to be aware of updates during the lifecycle of the settlement restriction.

Viewing settlement restriction on cash details is optional for the creation of a new settlement restriction on cash.

This business scenario is not relevant for CSD users, external CSD users and CSD participants.

### Privileges

To carry out this business scenario, you need the following privilege:

- Intra-balance movements query

### Reference

Further information on screens involved can be found in the screen reference part:

- Intra-balance movements – search/list* screen [▶ 422]
- Intra-balance movement – details* screen

### Instructions

1. Go to the *intra-balance movements – search/list* screen:  
Cash >> Settlement >> Intra-Balance Movements
2. Enter all search criteria known to you about the settlement restriction on cash for which you want to view the details.
3. Click on the *search* button.
  - ⇒ A list containing the search results is displayed on the screen.
  - ⇒ If the search retrieves only one settlement restriction on cash, the *intra-balance movement – details* screen is displayed directly.



### Alternative

To set all fields to default value and blank out all optional fields, click on the *reset* button.

4. Select the settlement restriction on cash for which you want to view the details by clicking on the entry in the list.
5. Click on the *details* button.
  - ➔ The *intra-balance movement – details* screen is displayed and you have viewed your settlement restriction on cash details.

## 3.6.3 Creation of a New Amendment Instruction for a Settlement Restriction on Securities

### Overview

This business package describes the creation of a new amendment instruction for a settlement restriction on securities.

You can create a new amendment instruction for a settlement restriction on securities and afterwards you can check the information of the amendment instruction in T2S.

To create a new amendment instruction for a settlement restriction on securities, carry out the business scenarios in the predefined order and choose the business scenario relevant to you whenever options are given.

### Business Scenarios

1. Create a new amendment instruction for a settlement restriction on securities
  - Add a link for a settlement restriction on securities [▶ 757]
  - Amend the priority for a settlement restriction on securities [▶ 760]
  - Remove a link for a settlement restriction on securities [▶ 762]
2. View amendment instruction for a settlement restriction on securities details [▶ 764]

### 3.6.3.1 Add a Link for a Settlement Restriction on Securities

### Context of Usage

This business scenario describes how to link a settlement restriction on securities (intra-position movement). You can link your settlement restriction on securities in case you want to settle it at the same time, after or before the settlement of another settlement restriction or settlement instruction.

Adding a link for a settlement restriction on securities is 1 option for the creation of an amendment instruction for a settlement restriction on securities.

Before you add a link to your settlement restriction on securities, check whether it is neither cancelled nor partially settled nor settled. You can check the status of your settlement restriction on securities before creating the amendment instruction through the details screen as described in the business scenario view settlement restriction on securities details [▶ 750].

The number of links that can be added per amendment instruction is unbounded. If you want to modify an already existing link in your settlement restriction on securities, you first have to remove the existing link and then add a new link to your settlement restriction on securities.

This business scenario is not relevant for CB users.

## Privileges

To carry out this business scenario, you need the following privileges:

- Amend process indicator of a settlement instruction/settlement restriction on securities either on a securities account or on behalf of the CSD in T2S or on behalf of an external CSD
- Amend process indicator of a non-modifiable settlement instruction on behalf of the instruction party of the underlying instruction
- Link to an instruction/pool reference belonging to a specific party
- Intra-position movements query
- Intra-position movement audit trail query
- Send new instruction using a specific instructing party

## Reference

Further information on screens involved can be found in the screen reference part:

- Intra-position movements – search/list* screen [▶ 136]
- Intra-position movement - details* screen
- Amendment securities instruction - new* screen [▶ 102]

## Instructions

1. Go to the *intra-position movements –search/list* screen:  
Securities >> Settlement >> Intra-Position Movements
2. Enter all search criteria known to you about the settlement restriction on securities you want to link.
3. Click on the *search* button.
  - ⇒ A list containing the search results is displayed on the screen.
  - ⇒ If the search retrieves only 1 intra-position movement, the *intra-position movement - details* screen is displayed directly. Proceed with step 6.
4. Select the settlement restriction on securities you want to amend by clicking on an entry in the list.
5. Click on the *details* button.

- ⇒ The *intra-position movement – details* screen is displayed.
- 6. Click on the *amendment instruction* button, located on the lower left side of the screen.
  - ⇒ The *amendment securities instruction - new* screen is displayed.
- 7. Enter all mandatory information in the 'General' frame.
- 8. Click on the *linkage information* radio button, located on the lower center side of the amendment securities screen.

Amendment Type

Priority  Linkage Information

- ⇒ The 'Linkage Information' and 'Link' frames are displayed.
- 9. Select the *link* radio button to add a link.

Linkage Information

LINK  UNLINK

- 10. Click on the *add row* icon in the 'Link' frame to display the links related enter fields.

Link

| Link Type        | Reference Type | Reference | Reference Owner | Options |
|------------------|----------------|-----------|-----------------|---------|
| No records found |                |           |                 |         |
|                  |                |           |                 | +       |

- 11. Enter the relevant information to identify the instruction you want your instruction to be linked with in the 'Link' frame and click on the *submit changes* icon in the 'Options' column.

Link

| Link Type | Reference Type | Reference | Reference Owner | Options |
|-----------|----------------|-----------|-----------------|---------|
| ...       | ...            |           |                 | ✓       |
|           |                |           |                 | +       |

- ⇒ The link has been added to the list.
- 12. To remove an entry from the list of links to be added, click on the *cancel changes* icon in the 'Options' column.
  - ⇒ The link has been deleted from the list.



### Repetition

To add more links, repeat steps 10 to 11.  
You can add as many links as you like.



### Alternative

To set all fields to default value and blank out all optional fields, click on the *reset* button.

To cancel the process and return to the previous screen, click on the *cancel* button.

13. Click on the *submit* button.

14. Enter your PIN for digital signature purposes (NRO).

- ➔ A new amendment instruction to add a link for a settlement restriction on securities has been created.

## 3.6.3.2 Amend the Priority for a Settlement Restriction on Securities

### Context of Usage

This business scenario describes how to amend the priority for a settlement restriction on securities (intra-position movement). You can create a new amendment instruction to amend the priority for your settlement restriction on securities in case you want to prioritise or delay its settlement.

Amending the priority for a settlement restriction on securities is one option for the creation of an amendment instruction for a settlement restriction on securities.

Before you amend the priority for your settlement restriction on securities, check whether it is neither cancelled nor settled. You can check the status of your settlement restriction on securities before creating the amendment instruction through the details screen as described in the business scenario view settlement restriction on securities details [▶ 750].

This business scenario is not relevant for CB users.

### Privileges

To carry out this business scenario, you need the following privileges:

- Amend process indication for a non-modifiable settlement instruction on behalf of the instruction party of the underlying instruction
- Amend process indicator of a settlement instruction/settlement restriction on securities either on a securities account or on behalf of the CSD in T2S or on behalf of an external CSD
- Send new instruction using a specific instructing party
- Intra-position movements query
- Intra-position movement audit trail list query
- Link to an instruction/pool reference belonging to a specific party

### Reference

Further information on screens involved can be found in the screen reference part:

- Intra-position movements – search/list* screen [▶ 136]



**Instructions**

- *Intra-position movement – details* screen
  - *Amendment securities instruction - new* screen [▶ 102]
1. Go to the *intra-position movements – search/list* screen:  
Securities >> Settlement >> Intra-Position Movements
  2. Enter at least one general search criterion known to you about the settlement restriction on securities you want to amend.
  3. Click on the *search* button.
    - ⇒ A list containing the search results is displayed on the screen.
    - ⇒ If the search retrieves only one intra-position movement, the *intra-position movement - details* screen is displayed directly. Proceed with step 6.
  4. Select the settlement restriction on securities for which you want to amend the priority by clicking on an entry in the list.
  5. Click on the *details* button.
    - ⇒ The *intra-position movement – details* screen is displayed.
  6. Check the current priority value and click on the *amendment instruction* button.
    - ⇒ The *amendment securities instruction - new* screen is displayed.
  7. Click on the *priority* radio button, located on the lower left-hand side of the screen.

Amendment Type

Priority  Linkage Information

⇒ The 'Priority' frame is displayed.

8. Select the new priority from drop-down menu.

Priority

Priority Level \*

High

Normal

Reserved

**Alternative**

To set all fields to default value and blank out all optional fields, click on the *reset* button.

To cancel the process and return to the previous screen, click on the *cancel* button.

9. Click on *submit* button.
10. Enter your PIN for digital signature purposes (NRO).

- ➔ A new amendment instruction to change the priority of a settlement restriction on securities has been created.

### 3.6.3.3 Remove a Link for a Settlement Restriction on Securities

#### Context of Usage

This business scenario describes how to remove an existing link in a settlement restriction on securities (intra-position movement).

Removing a link for a settlement restriction on securities is 1 option for the creation of a new amendment instruction for a settlement restriction on securities.

Before you remove a link for your settlement restriction on securities, check if it is neither settled nor cancelled. You can check the status of your settlement restriction on securities before creating the amendment instruction through the details screen as described in the business scenario view settlement restriction on securities details [▶ 750].

The number of links that can be removed per amendment instruction is limited to the number of existing linkages in the settlement restriction.

If you want to modify an already existing link in your settlement restriction on securities, first you have to remove the existing link and then add a new link to your settlement restriction on securities.

This business scenario is not relevant for CB users.

#### Privileges

To carry out this business scenario, you need the following privileges:

- Intra-position movements query
- Link to an instruction/pool reference belonging to a specific party
- Amend process indicator of a settlement instruction/settlement restriction on securities either on a securities account or on behalf of the CSD in T2S or on behalf of an external CSD
- Send new instruction using a specific instructing party

#### Reference

Further information on screens involved can be found in the screen reference part:

- Intra-position movements– search/list* screen [▶ 136]
- Intra-position movement – details* screen
- Amendment securities instruction - new* screen [▶ 102]

#### Instructions

1. Go to the *intra-position movements– search/list* screen:  
Securities >> Settlement >> Intra-Position Movements
2. Enter all search criteria known to you about the settlement restriction on securities you want to amend.
3. Click on the *search* button.

- ⇒ A list containing the search results is displayed on the screen.
- ⇒ If the search retrieves only one settlement restriction on securities, the *intra-position movement – details* screen is displayed directly. Proceed with step 6.
- 4. Select the settlement restriction on securities you want to amend by clicking on an entry in the list.
- 5. Click on the *details* button.
  - ⇒ The *intra-position movement – details* screen is displayed.
- 6. Click on the *amendment instruction* button, located on the lower left hand side of the screen.
  - ⇒ The *amendment securities instruction - new* screen is displayed.
- 7. Enter all mandatory information in the 'General' frame.
- 8. Click on the *linkage information* radio button, located on the lower center side of the amendment securities screen.

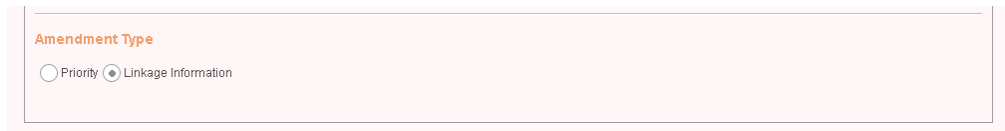

Amendment Type

Priority  Linkage Information

- ⇒ The 'Linkage Information' and 'Link' frames are displayed.
  - 9. Click on the *unlink* radio button
- 
- Linkage Information
- LINK  UNLINK
- ⇒ The existing links of the referenced settlement restriction on securities are displayed in the 'Link' frame below.
  - 10. Select the link(s) to be removed from the list.



### Alternatives

To set all fields to default value and blank out all optional fields, click on the *reset* button.

To cancel the process and return to the previous screen, click on the *cancel* button.

- 11. Click on the *submit* button.
- 12. Enter your PIN for digital signature purposes (NRO).
  - ➔ A new amendment instruction to remove a link for a settlement restriction on securities has been created.

### 3.6.3.4 View Amendment Instruction for a Settlement Restriction on Securities Details

**Context of Usage**

This business scenario describes how to view the details of an amendment instruction for a settlement restriction on securities. Once an amendment instruction for a settlement restriction on securities has been created in T2S it might be necessary for you to check its details to be aware of updates during the lifecycle of the amendment instruction.

Viewing an amendment instruction for a settlement restriction on securities details is optional for the creation of a new amendment instruction for a settlement restriction on securities.

This business scenario is not relevant for CB users.

**Privileges**

To carry out this business scenario, you need the following privileges:

- Maintenance for intra-position movements and settlement instructions query
- Amendment instruction query for intra-position movements and settlement instructions

**Reference**

Further information on screens involved can be found in the screen reference part:

- Maintenance securities instructions – search/list* screen [▶ 163]
- Amendment securities instruction – details* screen [▶ 97]

**Instructions**

1. Go to the *maintenance securities instructions – search/list* screen:  
Securities >> Settlement >> Maintenance Securities Instructions
2. Enter all search criteria known to you about the amendment instruction for a settlement restriction on securities for which you want to view the details.
3. Select the value 'Intra-Position Movement' in the 'Instruction Type' field.

4. Select the value 'Amendment Instruction' in the 'Maintenance Instruction Type' field.



### Alternative

To set all fields to default value and blank out all optional fields, click on the *re-set* button.

5. Click on the *search* button.
    - ⇒ A list containing the search results is displayed on the screen.
    - ⇒ If the search retrieves only one amendment instruction for a settlement restriction on securities, the *amendment securities instruction – details* screen is displayed directly.
  6. Select the amendment instruction for a settlement restriction on securities for which you want to view the details by clicking on an entry in the list.
  7. Click on the *details* button.
    - ⇒ The *amendment securities instruction – details* screen is displayed.
- ➔ You have viewed the details of an amendment instruction for a settlement restriction on securities.

## 3.6.4 Creation of a New Amendment Instruction for a Settlement Restriction on Cash

### Overview

This business package describes the creation of a new amendment instruction for a settlement restriction on cash.

You can create a new amendment instruction for a settlement restriction on cash and afterwards check if the amendment instruction has been successfully created or executed.

To create a new amendment instruction for a settlement restriction on cash, carry out the business scenarios in the predefined order and choose the business scenario relevant to you whenever options are given.

### Business Scenarios

1. Create a new amendment instruction for a settlement restriction on cash
  - Add a link for a settlement restriction on cash [▶ 766]
  - Amend the priority for a settlement restriction on cash [▶ 768]
  - Remove a link for a settlement restriction on cash [▶ 770]
2. View amendment instruction for a settlement restriction on cash details [▶ 772]

### 3.6.4.1 Add a Link for a Settlement Restriction on Cash

#### Context of Usage

This business scenario describes how to add a link for a settlement restriction on cash (intra-balance movement). You can link your settlement restriction on cash in case you want to settle it at the same time, after or before another settlement restriction or settlement instruction.

Adding a link for a settlement restriction on cash is one option for the creation of an amendment instruction for a settlement restriction on cash.

Before you add a link for a settlement restriction on cash, check whether it is neither cancelled nor partially settled nor settled. You can check the status of your settlement restriction on cash before creating the amendment instruction through the details screen as described in the business scenario view settlement restriction on cash details [▶ 756].

The number of links that can be added per amendment instruction is unbounded.

This business scenario is not relevant for CSD users.

#### Privileges

To carry out this business scenario, you need the following privileges:

- Link to an instruction/pool reference belonging to a specific party
- Amend process indicator settlement restriction on cash on a dedicated cash account
- Intra-balance movements query
- Intra-balance movement audit trail list query
- Send new instruction using a specific instructing party

#### Reference

Further information on screens involved can be found in the screen reference part:

- Intra-balance movements - search/list* screen [▶ 422]
- Intra-balance movement - details* screen
- Amendment cash instruction - new* screen [▶ 409]

#### Instructions

1. Go to the *intra-balance movements – search/list* screen:  
Cash >> Settlement >> Intra-Balance Movements
2. Enter all search criteria known to you about the settlement restriction on cash you want to link.
3. Click on the *search* button.
  - ⇒ A list containing the search results is displayed on the screen.
  - ⇒ If the search retrieves only 1 intra-balance movement, the *intra-balance movement - details* screen is displayed directly. Proceed with step 6.
4. Select the settlement restriction on cash you want to amend by clicking on an entry in the list.

5. Click on the *details* button.
  - ⇒ The *intra-balance movement - details* screen is displayed.
6. Click on the *amendment instruction* button, located on the bottom of the screen.
  - ⇒ The *amendment cash instruction - new* screen is displayed.
7. Enter all mandatory information in the 'General' frame.
8. Click on the *linkage information* radio button, located on the lower center side of the screen.

Amendment Type

Priority  Linkage Information

⇒ The 'Linkage Information' and 'Link' frames are displayed.

9. Select the *link* radio button to add a link.

Linkage Information

LINK  UNLINK

10. Click on the *add row* icon in the 'Link' frame to display the links related enter fields.

| Link Type        | Reference Type | Reference | Reference Owner | Options |
|------------------|----------------|-----------|-----------------|---------|
| No records found |                |           |                 |         |
|                  |                |           |                 | +       |

11. Enter the relevant information to identify the instruction you want your instruction to be linked with in the 'Link' frame and click on the *submit changes* icon in the 'Options' column.

| Link Type | Reference Type | Reference | Reference Owner | Options |
|-----------|----------------|-----------|-----------------|---------|
| ...       | ...            |           |                 | ✓       |
|           |                |           |                 | +       |

⇒ The link has been added to the list.

12. To remove an entry from the list of links to be added, click on the *cancel changes* icon in the 'Options' column.

⇒ The link has been deleted from the list.

**Repetition**

To add more links, repeat steps 10 to 11.  
You can add as many links as you like.

**Alternatives**

To set default criteria and blank out all optional fields, click on the *reset* button.  
To cancel the process and return to the previous screen, click on the *cancel* button.

13. Click on the *submit* button.

14. Enter your PIN for digital signature purposes (NRO).

- ➔ A new amendment instruction to add a link for a settlement restriction on cash has been created.

### 3.6.4.2 Amend the Priority for a Settlement Restriction on Cash

**Context of Usage**

This business scenario describes how to amend the priority for a settlement restriction on cash (intra-balance movement). You can create a new amendment instruction to amend the priority for your settlement restriction on cash to prioritise or delay its settlement. In case the settlement restriction on cash was originally sent without a priority, you can set it or modify the existing one.

Amending the priority for a settlement restriction on cash is 1 option for the creation of an amendment instruction for a settlement restriction on cash.

Before you amend the priority for your settlement restriction on cash, check whether it is neither cancelled nor settled. You can check the status of your settlement restriction on cash before creating the amendment instruction through the details screen as described in the business scenario view settlement restriction on cash details [▶ 756].

This business scenario is not relevant for CSD users.

**Privileges**

To carry out this business scenario, you need the following privileges:

- Amend process indicator settlement restriction on cash on a dedicated cash account
- Link to an instruction/pool reference belonging to a specific party
- Send new instruction using a specific instructing party
- Intra-balance movements query
- Intra-balance movement audit trail list query



**Reference** Further information on screens involved can be found in the screen reference part:

- Intra-balance movements – search/list* screen [▶ 422]
- Intra-balance movement – details* screen
- Amendment cash instruction - new* screen [▶ 409]

**Instructions**

1. Go to the *intra-balance movements –search/list* screen:  
Cash >> Settlement >> Intra-Balance Movements
2. Enter all search criteria known to you about the settlement restriction on cash for which you want to amend the priority.
3. Click on the *search* button.
  - ⇒ A list containing the search results is displayed on the screen.
  - ⇒ If the search retrieves only one intra-balance movement, the *intra-balance movement - details* screen is displayed directly. Proceed with step 6.
4. Select the settlement restriction on cash you want to amend by clicking on an entry in the list.
5. Click on the *details* button.
  - ⇒ The *intra-balance movement – details* screen is displayed.
6. Check the current priority value and click on the *amendment instruction* button.
  - ⇒ The *amendment cash instruction – new* screen is displayed.
7. Click on the *priority* radio button, located on the lower center side of the screen.

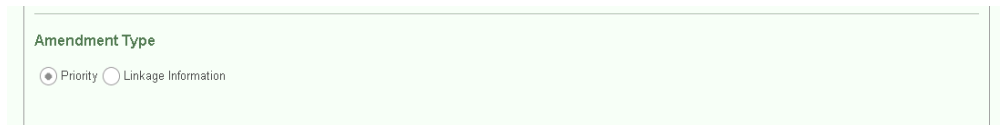

Amendment Type

Priority  Linkage Information

⇒ The 'Priority' frame is displayed.

8. Select the new priority from the drop-down menu.



Priority

Priority Level \*

High

Normal

Reserved



**Alternatives**

To set all fields to default value and blank out all optional fields, click on the *reset* button.

To cancel the process and return to the previous screen, click on the *cancel* button.

9. Click on the *submit* button.
10. Enter your PIN for digital signature purposes (NRO).
  - ➔ A new amendment instruction for a settlement restriction on cash has been created.

### 3.6.4.3 Remove a Link for a Settlement Restriction on Cash

#### Context of Usage

This business scenario describes how to remove an existing link in a settlement restriction on cash (intra-balance movement).

Removing a link for a settlement restriction on cash is one option for the creation of an amendment instruction for a settlement restriction on cash.

Before you remove a link for your settlement restriction on cash, check whether it is neither settled nor cancelled. You can check the status of your settlement restriction on cash before creating the amendment instruction through the details screen as described in the business scenario view settlement restriction on cash details [▶ 756].

The number of links that can be removed with one amendment instruction is limited to the number of existing linkages in the settlement restriction on cash.

If you want to modify an already existing link in your settlement restriction on cash, you have first to remove the existing link and then add a new link to your settlement restriction on cash.

This business scenario is not relevant for CSD users.

#### Privileges

To carry out this business scenario, you need the following privileges:

- Link to an instruction/pool reference belonging to a specific party
- Amend process indicator settlement restriction on cash on a dedicated cash account
- Send new instruction using a specific instructing party
- Intra balance movement query

#### Reference

Further information on screens involved can be found in the screen reference part:

- Intra-balance movements – search/list* screen [▶ 422]
- Intra-balance movement – details* screen
- Amendment cash instruction - new* screen [▶ 409]

#### Instructions

1. Go to the *intra-balance movements – search/list* screen:  
Cash >> Settlement >> Intra-Balance Movements
2. Enter all search criteria known to you about the settlement restriction on cash you want to amend.

3. Click on the *search* button.
  - ⇒ A list containing the search results is displayed on the screen.
  - ⇒ If the search retrieves only one settlement restriction on cash, the *intra-balance movement – details* screen is displayed directly. Proceed with step 6.
4. Select the settlement restriction on cash you want to amend by clicking on an entry in the list.
5. Click on the *details* button.
  - ⇒ The *intra-balance movement – details* screen is displayed.
6. Click on the *amendment cash instruction* button.
  - ⇒ The *amendment cash instruction – new* screen is displayed.
7. Enter all mandatory information in the ‘General’ frame.
8. Click on the *linkage information* radio button, located on the lower center side of the *amendment cash instruction – new* screen.

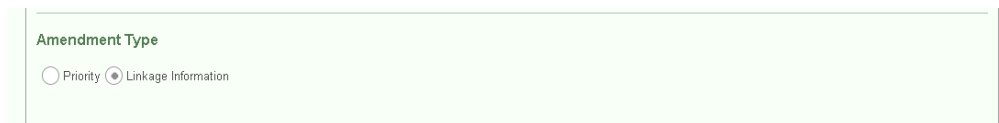

Amendment Type

Priority  Linkage Information

- ⇒ The ‘Linkage Information’ and ‘Link’ frames are displayed.
9. Select the *unlink* radio button to remove a link.



Linkage Information

LINK  UNLINK

- ⇒ The existing links of the referenced settlement restriction on cash are displayed in the ‘Link’ frame below.
10. Select the link(s) to be removed from the list.



### Alternatives

To set all fields to default value and blank out all optional fields, click on the *reset* button.

To cancel the process and return to the previous screen, click on the *cancel* button.

11. Click on the *submit* button.
12. Enter your PIN for digital signature purposes (NRO).
  - ➔ A new amendment instruction to remove a link for a settlement restriction on cash has been created.

### 3.6.4.4 View Amendment Instruction for a Settlement Restriction on Cash Details

#### Context of Usage

This business scenario describes how to view the details of an amendment instruction for a settlement restriction on cash. Once an amendment instruction for a settlement restriction on cash has been created in T2S it might be necessary for you to check its details to be aware of updates during the lifecycle of the amendment instruction.

Viewing an amendment instruction for a settlement restriction on cash details is optional for the creation of a new amendment instruction for a settlement restriction on cash.

This business scenario is not relevant for CSD users.

#### Privileges

To carry out this business scenario, you need the following privileges:

- Maintenance instruction for intra-balance movements query
- Amendment instruction query for intra-balance movements

#### Reference

Further information on screens involved can be found in the screen reference part:

- Maintenance cash instructions – search/list* screen [▶ 447]
- Amendment cash instruction - details* screen [▶ 404]

#### Instructions

1. Go to the *maintenance cash instructions – search/list* screen:  
Cash >> Settlement >> Maintenance Cash Instructions
2. Enter all search criteria known to you about the amendment instruction for a settlement restriction on cash for which you want to view the details.
3. Check that the value selected in the 'Maintenance Instruction Type' field is 'Amendment Instruction' (i.e. it is the default value for this field).

The screenshot shows a search criteria form for 'Maintenance Cash Instructions'. The form has several input fields and dropdown menus. The 'Maintenance Instruction Type' dropdown menu is highlighted with a red box and shows 'Amendment Instruction' selected. Other fields include Actor Reference, T2S Reference, Instructing Party Parent BIC, Instructing Party BIC, Dedicated Cash Account, Entry Date, Execution Date, Execution Status, and Cancellation Status.



#### Alternative

To set all fields to default value and blank out all optional fields, click on the *reset* button.

4. Click on the *search* button.
  - ⇒ A list containing the search results is displayed on the screen.

⇒ If the search retrieves only one amendment instruction for a settlement restriction on cash, the *amendment cash instruction - details* screen is displayed directly.

5. Select the amendment instruction for a settlement restriction on cash for which you want to view the details by clicking on an entry in the list.

6. Click on the *details* button.

⇒ The *amendment cash instruction – details* screen is displayed.

➔ You have viewed the details of an amendment instruction for a settlement restriction on cash.

### 3.6.5 Creation of a New Cancellation Instruction for a Settlement Restriction on Securities

#### Overview

This business package describes the creation of a new cancellation instruction for a settlement restriction on securities.

You can create a new cancellation instruction for a settlement restriction on securities and afterwards you can check the information of the cancellation instruction in T2S.

To create a new cancellation instruction for a settlement restriction on securities, carry out the following business scenarios in the predefined order.

#### Business Scenarios

1. Cancel a settlement restriction on securities [▶ 773]
2. View cancellation instruction for a settlement restriction on securities details [▶ 775]

#### 3.6.5.1 Cancel a Settlement Restriction on Securities

#### Context of Usage

This business scenario describes how to create a new cancellation instruction for a settlement restriction on securities. This is necessary if you want to cancel a settlement restriction on securities so it is not processed further in T2S.

Cancelling a settlement restriction on securities is mandatory for the creation of a cancellation instruction for a settlement restriction on securities.

Before you create a new cancellation instruction for a settlement restriction on securities, check that it is not already cancelled nor settled. You can check the status of your settlement restriction on securities before creating the cancellation instruction through the details screen as described in the business scenario view settlement restriction on securities details [▶ 750].

This business scenario is not relevant for CB users.

#### Privileges

To carry out this business scenario, you need the following privileges:

- Intra-position movements query

- Intra-position movement audit trail list query
- Cancel non-modifiable instructions on behalf of the instruction party of the underlying settlement instruction
- Cancel settlement instruction/settlement restriction on securities either on a securities account or on behalf of the CSD in T2S, on behalf of an external CSD or on behalf of an administering party
- Send new instruction using a specific instructing party

**Reference**

Further information on screens involved can be found in the screen reference part:

- Intra-position movements – search/list* screen [▶ 136]
- Intra-position movement - details* screen
- Cancellation securities instruction - new* screen [▶ 116]

**Instructions**

1. Go to the *intra-position movements – search/list* screen:  
`Securities >> Settlement >> Intra-Position Movements`
2. Enter at least one general search criterion known to you about the settlement restriction on securities for which you want to view the details.
3. Click on the *search* button.
  - ⇒ A list containing the search results is displayed on the screen.
  - ⇒ If the search retrieves only one settlement restriction on securities, the *intra-position movement - details* screen is displayed directly. Proceed with step 6.
4. Select the settlement restriction on securities you want to cancel by clicking on an entry in the list.
5. Click on the *details* button.
  - ⇒ The *intra-position movement - details* screen is displayed.
6. Click on the *cancellation instruction* button.
  - ⇒ The *cancellation securities instruction - new* screen is displayed.
7. Enter all relevant information in the 'General' frame.

**Alternative**

To set all fields to default value and blank out all optional fields, click on the *reset* button.

To cancel the process and return to the previous screen, click on the *cancel* button.

8. Click on the *submit* button.
9. Enter your PIN for digital signature purposes (NRO).

- ➔ A new cancellation instruction for a settlement restriction on securities has been created.

### 3.6.5.2 View Cancellation Instruction for a Settlement Restriction on Securities Details

#### Context of Usage

This business scenario describes how to view the details of a cancellation instruction for a settlement restriction on securities. Once the cancellation instruction for a settlement restriction on securities is created in T2S it might be necessary for you to check its details to be aware of updates during the lifecycle of the cancellation instruction.

Viewing a cancellation instruction for a settlement restriction on securities details is optional for the creation of a new cancellation instruction for a settlement restriction on securities.

This business scenario is not relevant for CB users.

#### Privileges

To carry out this business scenario, you need the following privileges:

- Maintenance for intra position movements and settlement instructions query
- Cancellation instruction query for intra-position movements and settlement instructions
- Cancellation instruction for intra-position movement or settlement instruction audit trail details query
- Amendment instruction query for intra-position movements and settlement instructions

#### Reference

Further information on screens involved can be found in the screen reference part:

- Maintenance securities instructions – search/list* screen [▶ 163]
- Cancellation securities instruction - details* screen [▶ 112]

#### Instructions

1. Go to the *maintenance securities instructions – search/list* screen:  
Securities >> Settlement >> Maintenance Securities Instructions
2. Enter all search criteria known to you about the cancellation instruction for a settlement restriction on securities for which you want to view the details.
3. Select the value 'Intra-Position Movement' in the 'Instruction Type\*' field.

4. Select the value 'Cancellation Instruction' in the 'Maintenance Instruction Type' field.

5. Select the value 'Cancellation Instruction' from the 'Maintenance Instruction Type' field in the 'General Criteria' frame to search for a cancellation instruction. If the relevant value is not selected, the default value 'All' applies.



### Alternative

To set all fields to default value and blank out all optional fields, click on the *reset* button.

6. Click on the *search* button.

- ⇒ A list containing the search results is displayed on the screen.
- ⇒ If the search retrieves only one cancellation instruction for a settlement restriction on securities, the *cancellation securities instruction - details* screen is displayed directly.

7. Select the cancellation instruction for a settlement restriction on securities for which you want to view the details.

8. Click on the *details* button.

- ⇒ The *cancellation securities instruction – details* screen is displayed.



- ➔ You have viewed the details of a cancellation instruction for a settlement restriction on securities.

## 3.6.6 Creation of a New Cancellation Instruction for a Settlement Restriction on Cash

### Overview

This business package describes the creation of a new cancellation instruction for a settlement restriction on cash.

You can create a new cancellation instruction for a settlement restriction on cash and afterwards you can check if the cancellation instruction has been successfully created or executed.

To create a new cancellation instruction for a settlement restriction on cash, carry out the following business scenarios in the predefined order.

### Business Scenarios

1. Cancel a settlement restriction on cash [[▶ 777](#)]
2. View cancellation instruction for a settlement restriction on cash details [[▶ 778](#)]

### 3.6.6.1 Cancel a Settlement Restriction on Cash

### Context of Usage

This business scenario describes how to create a new cancellation instruction for a settlement restriction on cash. This is necessary if you want to cancel a settlement restriction on cash so it is not further processed in T2S.

Cancelling a settlement restriction on cash is mandatory for the creation of a cancellation instruction for a settlement restriction on cash.

Before you create a new cancellation instruction for a settlement restriction on cash, check that it is neither already cancelled nor settled. You can check the status of your settlement restriction on cash before creating the cancellation instruction on the details screen as described in the business scenario view settlement restriction on cash details [[▶ 756](#)].

This business scenario is not relevant for CSD users.

### Privileges

To carry out this business scenario, you need the following privileges:

- Intra-balance movements query
- Intra-balance movement audit trail list query
- Cancel settlement restriction on cash on a dedicated cash account
- Send new instruction using a specific instructing party

### Reference

Further information on screens involved can be found in the screen reference part:

- Intra-balance movements – search/list* screen [[▶ 422](#)]
- Intra-balance movement - details* screen

**Instructions**

- **Cancellation cash instruction - new screen** [▶ 419]
  1. Go to the *intra-balance movements – search/list* screen:  
Cash >> Settlement >> Intra-Balance Movements
  2. Enter at least one general search criterion known to you about the settlement restriction on cash for which you want to view the details.
  3. Click on the *search* button.
    - ⇒ A list containing the search results is displayed on the screen.
    - ⇒ If the search retrieves only one settlement restriction on cash, the *intra-balance movement - details* screen is displayed directly. Proceed with step 6.
  4. Select the settlement restriction on cash you want to cancel by clicking on an entry in the list.
  5. Click on the *details* button.
    - ⇒ The *intra-balance movement - details* screen is displayed.
  6. Click on the *cancellation instruction* button.
    - ⇒ The *cancellation cash instruction - new screen* is displayed.
  7. Enter all relevant information in the 'General' frame.

**Alternative**

To set all fields to default value and blank out all optional fields, click on the *reset* button.

To cancel the process and return to the previous screen, click on the *cancel* button.

8. Click on the *submit* button.
9. Enter your PIN for digital signature purposes (NRO).
  - ➔ A new cancellation instruction for a settlement restriction on cash has been created.

### 3.6.6.2 View Cancellation Instruction for a Settlement Restriction on Cash Details

**Context of Usage**

This business scenario describes how to view the details of a cancellation instruction for a settlement restriction on cash. Once a cancellation instruction is created in T2S it might be necessary for you to check its details to be aware of updates during the lifecycle of the cancellation instruction.

Viewing a cancellation instruction for a settlement restriction on cash details is one option for the creation of a new cancellation instruction for a settlement restriction on cash.

This business scenario is not relevant for CSD users.

## Privileges

To carry out this business scenario, you need the following privileges:

- Cancellation instructions for intra-balance movements query
- Maintenance instructions for intra-balance movements query
- Cancellation instruction for intra-balance movement audit trail list query
- Amendment instruction query for intra-balance movements
- Amendment instruction for intra-balance movement audit trail list query

## Reference

Further information on screens involved can be found in the screen reference part:

- Maintenance cash instructions – search/list* screen [▶ 447]
- Cancellation cash instruction - details* screen [▶ 416]

## Instructions

1. Go to the *maintenance cash instructions – search/list* screen:  
Cash >> Settlement >> Maintenance Cash Instructions
2. Enter at least one general search criterion known to you about the cancellation instruction for a settlement restriction on cash for which you want to view the details.
3. Select the value 'Cancellation Instruction' in the 'Maintenance Instruction Type' field.

Search Criteria - Maintenance Cash Instructions

|   |                                  |                        |
|---|----------------------------------|------------------------|
| Actor Reference                                       | T2S Reference                    |                        |
| <input type="text"/>                                  | <input type="text"/>             |                        |
| Instructing Party Parent BIC                          | Instructing Party BIC            | Dedicated Cash Account |
| <input type="text"/>                                  | <input type="text"/>             | <input type="text"/>   |
| Maintenance Instruction Type                          | Entry Date                       | Execution Date         |
| <input type="text" value="Cancellation Instruction"/> | <input type="text"/>             | <input type="text"/>   |
| Amendment Instruction                                 | Cancellation Status              |                        |
| <input type="text"/>                                  | <input type="text" value="All"/> |                        |
| Cancellation Instruction                              |                                  |                        |
| <input type="text"/>                                  |                                  |                        |

4. Click on the *search* button.
  - ⇒ A list containing the search results is displayed on the screen.
  - ⇒ If the search retrieves only one cancellation instruction for a settlement restriction on cash, the *cancellation cash instruction - details* screen is displayed directly.
5. Select the cancellation instruction for a settlement restriction on cash for which you want to view the details.



## Alternative

To set all fields to default value and blank out all optional fields, click on the *reset* button.

6. Click on the *details* button.

⇒ The *cancellation cash instruction - details* screen is displayed.

- ➔ You have viewed the details of a cancellation instruction for a settlement restriction on cash.

### 3.6.7 View the list of links data preventing settlement of a settlement restriction on securities

#### Context of Usage

This business scenario describes how to view the list of data preventing settlement of a selected settlement restriction on securities.

When a linked settlement restriction on securities is unsettled, it might be useful for you to check the list of the settlement instructions or settlement restrictions preventing its settlement with the associated constraints.

This business scenario is not relevant for the following cases:

- Settled, cancelled settlement restrictions on securities
- Settlement restrictions on securities with an intended settlement date in the future

#### Privileges

To carry out this business scenario, you need the following privileges:

- Intra-position movements query

#### Reference

Further information on screens involved can be found in the screen reference part:

- Intra-position movements – search/list screen
- Intra-position movement – details screen
- Links preventing settlement – list screen

#### Instructions

1. Go to the intra-position movements – search/list screen:  
Securities Settlement Intra-position Movements
2. Enter at least one general search criterion known to you about the settlement restriction on securities for which you want to view the links data preventing its settlement.
3. Click on the search button.
  - A list containing the search results is displayed on the screen
  - If the search retrieves only one settlement restriction on securities, the intra-position movement – details screen is displayed directly. Proceed with step 6.
4. Select the settlement on securities for which you want to view the links data preventing settlement by clicking on an entry in the list.
5. Click on the details button.
  - The intra-position movement – details screen is displayed.

6. Check the details of the settlement restriction on securities and click on the links button.
  - The links preventing settlement – list screen is displayed.
  - You have viewed the list of the settlement instructions and/or settlement instructions preventing the settlement of the selected settlement restriction on securities with the associated constraints.

### 3.6.8 View the list of links data preventing settlement of a settlement restriction on cash

#### Context of Usage

This business scenario describes how to view the list of data preventing settlement of a selected settlement restriction on cash.

When a linked settlement restriction on cash is unsettled, it might be useful for you to check the list of the settlement instructions or settlement restrictions preventing its settlement with the associated constraints.

This business scenario is not relevant for the following cases:

- Settled, cancelled settlement restrictions on cash
- Settlement restrictions on cash with an intended settlement date in the future

#### Privileges

To carry out this business scenario, you need the following privileges:

- Intra balance movement audit trail list query

#### Reference

Further information on screens involved can be found in the screen reference part:

- Intra-balance movements – search/list screen
- Intra-balance movement – details screen
- Links preventing settlement – list screen

#### Instructions

1. Go to the intra-balance-movements – search/list screen:  
Cash Settlement Intra-balance Movements
2. Enter at least one general search criterion known to you about the settlement restriction on cash for which you want to view the links data preventing its settlement.
3. Click on the search button
  - A list containing the search results is displayed on the screen
  - If the search retrieves only one settlement restriction on cash, the intra-position movement – details screen is displayed directly. Proceed with step 6.
4. Select the settlement on cash for which you want to view the links data preventing settlement by clicking on an entry in the list.

- 
5. Click on the details button.
    - The intra-balance movement – details screen is displayed.
  6. Check the details of the settlement restriction on cash and click on the links button.
    - The links preventing settlement – list screen is displayed.
    - You have viewed the list of the settlement instructions and/or settlement instructions preventing the settlement of the selected settlement restriction on cash with the associated constraints.

---

## 4 Trouble Management System Part

### 4.1 General

#### General

The Trouble Management System (TMS) part offers an overview of the TMS screens that are available in U2A mode. The aim of this section is to provide a guide which describes and explains the usage and the functionalities of the TMS external interface to the relevant users.

TMS is a tool and database which is used to track and follow-up on relevant communication between the T2S users and the T2S Service Desk for which a trouble case has been created.

The T2S Service Desk is responsible for opening a trouble case ticket whenever it is contacted by a T2S user who would like to raise a service request or who experiences problems (e. g. due to abnormal situations or reduced performance) with T2S. In TMS a trouble case is classified either as service request or incident.

A *service request* is a trouble case to track information requests or information on any specific issue that is part of standard operation.

An *incident* is a trouble case reporting any event which does not fall within standard operation and causes an interruption or reduction in quality of a T2S service.

#### Access to TMS

Please refer to ESMIG qualified configurations document annexed to the ESMIG UDFS.

#### Statuses in TMS

A status is assigned by the T2S Service Desk to every trouble case and will change during its life cycle. For a complete list of statuses see chapter 4.2.2 (*Trouble Case – Details Screen*).

#### Priorities in TMS

The T2S Service Desk has to assign a priority to every trouble case created in TMS. There are four different priority types in TMS: *Low*, *Medium*, *Urgent*, and *Critical*. *Low* is usually assigned to service requests and any incident which does not affect the T2S performance directly. *Medium* is the priority for trouble case incidents affecting the performance moderately but with no impact on the general availability of T2S services. *Urgent* is the priority assigned to incident cases which describe the unavailability of one or more services or a heavily impacted overall performance of the T2S system. A workaround has to be put in place within the defined time according to the T2S Service Level Agreement. In case of complete unavailability of the T2S System, the priority *Critical* is assigned to the TMS trouble case.

#### Screen Reference Part

The screen reference part offers a complete overview of all TMS screens that are available to the T2S users including a detailed description.

- Context of Usage**      The context of usage explains what a screen displays, the functions of the screen and which information you can get from it, e.g. the resolution progress of a trouble case. It also defines the different options of monitoring of a trouble case.
- Screen Access**      This part explains how to access the different available screens. Please note that with the exception of the main screen, all screens are pop-up screens which can be accessed directly from the main screen. Screen access explains how to open these pop-up screens.
- Reference**            This section lists all references to the business scenarios containing the respective screen (reference to the user instructions part).
- Screenshot**          The screenshot can help to ease orientation for the work in the UHB. Deviations between the screenshot and the description are possible in case of specific selections you have made. Values shown in the screenshot might deviate from the default values indicated in the description.
- Field Description**    The field description provides all the relevant information related to the respective field name.  
  
It is structured in table format with a separate table for each frame. The following illustration explains the structure of a field description.

| 1 Case Details           |  |
|--------------------------|--|
| Institution              | Shows the parent BIC and party BIC related to the trouble case.  |
| 2 Trouble Case ID        | 3 Shows the alphanumeric number of the trouble case assigned by the system.<br>4 Note: In case of incidents and service requests the trouble case ID always starts with 'INC', in case of problems with 'PBI'. |
| Customer Trouble Case ID | Shows the number of the trouble case assigned by the customer.   |
| Case Type                | Shows the case type of the trouble case from the possible values:<br><ul style="list-style-type: none"> <li>  Incident</li> <li>  Problem</li> <li>  Service Request</li> </ul>                                |
| Open Date                | Shows the date and time of the opening of the trouble case.<br>5 Displayed format is: MM/DD/YYYY hh:mm:ss  |



| Position No. | Element                   | Description  |
|--------------|---------------------------|--|
| 1            | Frame Name                | The frame name indicates the respective name of each screen frame.   |
| 2            | Field Name                | The field name indicates the respective name of each screen field.   |
| 3            | Field description         | The field description indicates the field type as well as possible and/or required content.  |
| 4            | Additional Information    | The additional information section indicates useful information regarding a field's or button's function.  |
| 5            | Required/Displayed format | <p>The required/displayed format indicates all field format requirements related to the fields. If there is more than 1 format requirement, they are separated with a comma.</p> <p>In read-only fields the displayed format is only mentioned, if the field content is ambiguous. This applies especially to date fields.</p> <p>The following keywords are used for the format requirements:</p> <ul style="list-style-type: none"> <li><input type="checkbox"/> 'Digit' indicates numbers</li> <li><input type="checkbox"/> 'Character' indicates a character from the SWIFT-x character set</li> </ul> |

### User Instructions Part

The user instructions part comprises scenarios adapted from typical user workflows grouped in a business package.

#### List of Business Scenarios

This section contains a list of all business scenarios which represent individual workflows and consist of single action steps, intermediate results and a final result.

#### Instructions

The instructions section explains in detail which steps have to be taken e. g. to view a trouble case. This section lists all references to the screens involved, sorted by their appearance in the business scenario.

## 4.2 Screen Reference Part

### 4.2.1 Trouble Case – Search/List Screen

**Context of Usage**

This screen contains a number of search fields. By inputting the relevant data, you can search for trouble cases (incidents/requests and problems) related to your system entity, trouble cases opened by parties related to your system entity and in addition trouble cases of general importance visible to all parties (default). After selecting an entry, you can proceed further by clicking on the buttons below.

**Screen Access**

This screen is the main screen of the Trouble Management System (TMS) and appears directly when accessing the TMS.

**References**

**User Instructions Part**

This screen is part of the following business scenarios:

- View trouble case [▶ 805]
- Execute a report [▶ 805]

**Screenshot**

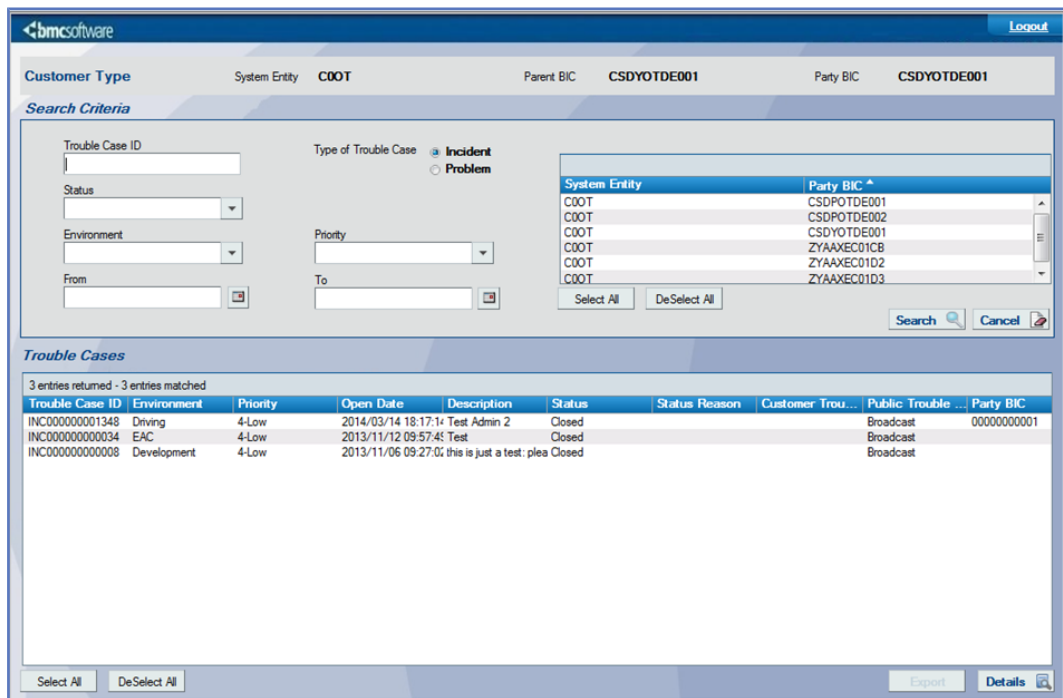

Illustration 131: Trouble case – list screen

**Field Description**

| Trouble Case – Search/List |  |
|----------------------------|--|
| <b>Customer Type</b>       |  |
| System Entity              | Shows the system entity your user belongs to.                |
| Parent BIC                 | Shows the parent BIC of your party.                          |
| Party BIC                  | Shows all the possible party BICs related to the parent BIC. |
| <b>Search Criteria</b>     |  |

| Trouble Case – Search/List |   |
|----------------------------|---|
| Trouble Case ID            | Enter a trouble case ID number of the T2S TMS for single search (available both for problems and incidents).  |
| Status                     | <p>Select the status of the trouble case.</p> <p>If the type of trouble case is set to 'Incident', select the status of the trouble case from the possible values:</p> <ul style="list-style-type: none"> <li><input type="checkbox"/> Assigned</li> <li><input type="checkbox"/> In Progress</li> <li><input type="checkbox"/> Pending</li> <li><input type="checkbox"/> Resolved</li> <li><input type="checkbox"/> Closed</li> <li><input type="checkbox"/> Cancelled</li> <li><input type="checkbox"/> All Open</li> <li><input type="checkbox"/> (Empty) (default value no filter will be applied)</li> </ul> <p>If the type of trouble case is set to 'Problem', select the status of the trouble case from the possible values:</p> <ul style="list-style-type: none"> <li><input type="checkbox"/> Under Review</li> <li><input type="checkbox"/> Request for Authorization</li> <li><input type="checkbox"/> Assigned</li> <li><input type="checkbox"/> Under Investigation</li> <li><input type="checkbox"/> Pending</li> <li><input type="checkbox"/> Completed</li> <li><input type="checkbox"/> Rejected</li> <li><input type="checkbox"/> Closed</li> <li><input type="checkbox"/> Cancelled</li> <li><input type="checkbox"/> All Open</li> <li><input type="checkbox"/> (Empty) (default value no filter will be applied)</li> </ul> |
| Environment                | <p>Select the environment of the trouble case.</p> <ul style="list-style-type: none"> <li><input type="checkbox"/> Production</li> <li><input type="checkbox"/> Customer</li> <li><input type="checkbox"/> INTEG</li> <li><input type="checkbox"/> Driving</li> <li><input type="checkbox"/> Development</li> <li><input type="checkbox"/> IAC</li> </ul>   |

| Trouble Case – Search/List |  |
|----------------------------|--|
|                            | <input type="checkbox"/> EAC<br><input type="checkbox"/> MIG1<br><input type="checkbox"/> MIG2<br><input type="checkbox"/> UTEST<br><input type="checkbox"/> (Empty) (default value no filter will be applied)   |
| Priority                   | Select the Priority of the trouble case.<br><input type="checkbox"/> 1 – Critical<br><input type="checkbox"/> 2 – Urgent<br><input type="checkbox"/> 3 – Medium<br><input type="checkbox"/> 4 – Low<br><input type="checkbox"/> (Empty) (default value no filter will be applied)  |
| Type of Trouble Case*      | Select the type of trouble case from the possible values:<br><input type="checkbox"/> Incident (default value)<br><input type="checkbox"/> Problem<br>Note: Case type = Request is classified as type of trouble case = Incident (further distinction available in the ‘Trouble Cases part’).  |
| From                       | Enter the lower bound of the search range for the date and time from which the trouble case is opened or use the <i>calendar</i> icon.<br>Required format is: YYYY/MM/DD hh:mm:ss<br>The ‘From’ date and time must be a valid date earlier than or equal to the current business and earlier than or equal to the ‘To’ date and time.<br>Reference for error message [ ▶ 1124]:<br><input type="checkbox"/> ARERR10000 |
| To                         | Enter the upper bound of the search range for the date and time until which the trouble case is opened or use the <i>calendar</i> icon.<br>Required format is: YYYY/MM/DD hh:mm:ss<br>The ‘To’ date and time must be a valid date later than or equal to the ‘From’ date and time.<br>Reference for error message [ ▶ 1124]:<br><input type="checkbox"/> ARERR10000  |

| Trouble Case – Search/List |  |
|----------------------------|--|
| Costumer                   | Select the party BIC related to your system entity you want to include in your search result.<br><br>You can select more than one related party BIC.   |
| Trouble Cases              |  |
| Trouble Case ID            | Shows the alphanumeric number of the trouble case assigned by the system.<br><br>Note: In case of incidents and requests, the Trouble Case ID always starts with 'INC'. In case of problems the Trouble Case ID always starts with 'PBI'.  |
| Environment                | Shows the environment chosen for the ticket. Normally it is the environment where the issue was detected.  |
| Priority                   | Shows the priority assigned to the ticket from the possible values:<br><br><input type="checkbox"/> Critical<br><input type="checkbox"/> Urgent<br><input type="checkbox"/> Medium<br><input type="checkbox"/> Low   |
| Open Date                  | Shows the date and time the trouble case have been opened.<br><br>Displayed format is: YYYY/MM/DD hh:mm:ss   |
| Description                | Shows the description of the trouble case.   |
| Status                     | Shows the current status of the trouble case.<br><br>If the type of trouble case is set to 'Incident', this field shows the status from the possible values:<br><br><input type="checkbox"/> Assigned<br><input type="checkbox"/> In Progress<br><input type="checkbox"/> Pending<br><input type="checkbox"/> Resolved<br><input type="checkbox"/> Closed<br><input type="checkbox"/> Cancelled<br><input type="checkbox"/> All Open<br><input type="checkbox"/> (Empty) (default value no filter will be applied)<br><br>If the type of trouble case is set to 'Problem', this field shows the status from the possible values: |

| Trouble Case – Search/List |   |
|----------------------------|---|
|                            | <ul style="list-style-type: none"> <li><input type="checkbox"/> Under Review</li> <li><input type="checkbox"/> Request for Authorization</li> <li><input type="checkbox"/> Assigned</li> <li><input type="checkbox"/> Under Investigation</li> <li><input type="checkbox"/> Pending</li> <li><input type="checkbox"/> Completed</li> <li><input type="checkbox"/> Rejected</li> <li><input type="checkbox"/> Closed</li> <li><input type="checkbox"/> Cancelled</li> <li><input type="checkbox"/> All Open</li> <li><input type="checkbox"/> (Empty) (default value no filter will be applied)</li> </ul>   |
| Status Reason              | <p>Shows the reason for the current status of the trouble case.</p> <p>If the status of the trouble case is set to 'Pending', this field shows the reason from the possible values:</p> <ul style="list-style-type: none"> <li><input type="checkbox"/> Automated Resolution Reported</li> <li><input type="checkbox"/> Client Hold</li> <li><input type="checkbox"/> Client Action Required</li> <li><input type="checkbox"/> Support Contact Hold</li> <li><input type="checkbox"/> Local Site Action Required</li> <li><input type="checkbox"/> Purchase Order Approval</li> <li><input type="checkbox"/> Registration Approval</li> <li><input type="checkbox"/> Supplier Delivery</li> <li><input type="checkbox"/> Third Party Vendor Action Required</li> <li><input type="checkbox"/> Infrastructure Change (only if Case Type is set to 'Problem')</li> <li><input type="checkbox"/> Pending Original Problem (only if Case Type is set to 'Problem')</li> <li><input type="checkbox"/> Request</li> <li><input type="checkbox"/> Monitoring Incident</li> <li><input type="checkbox"/> Monitoring Problem (only if Case Type is set to 'Problem')</li> <li><input type="checkbox"/> Future Enhancement</li> </ul> |

| Trouble Case – Search/List |   |
|----------------------------|---|
|                            | <p>If the status of the trouble case is set to 'Resolved', this field shows the reason from the possible values:</p> <ul style="list-style-type: none"> <li><input type="checkbox"/> Automated Resolution Reported</li> <li><input type="checkbox"/> Customer Follow-Up Required</li> <li><input type="checkbox"/> Temporary Corrective Action</li> <li><input type="checkbox"/> Future Enhancement</li> <li><input type="checkbox"/> Monitoring Incident</li> <li><input type="checkbox"/> No Further Action Required</li> </ul> <p>If the status of the trouble case is set to 'Closed', this field shows the reason from the possible values:</p> <ul style="list-style-type: none"> <li><input type="checkbox"/> Successful</li> <li><input type="checkbox"/> Successful with Problem</li> <li><input type="checkbox"/> Unsuccessful</li> <li><input type="checkbox"/> (Empty)</li> </ul> <p>If the status of the trouble case is set to 'Completed', this field shows the reason from the possible values:</p> <ul style="list-style-type: none"> <li><input type="checkbox"/> Known Error</li> <li><input type="checkbox"/> Solution Database</li> <li><input type="checkbox"/> Enhancement Request</li> <li><input type="checkbox"/> Unresolvable</li> </ul> <p>If the status of the trouble case is set to 'Cancelled', this field shows the reason from the possible values:</p> <ul style="list-style-type: none"> <li><input type="checkbox"/> No longer a Causal CI (only in case of incident/request ticket)</li> <li><input type="checkbox"/> Duplicate Investigation (only if Case Type is set to 'Problem')</li> <li><input type="checkbox"/> Not a Defect (only in case of problem tickets)</li> <li><input type="checkbox"/> (Empty)</li> </ul> <p>This field is only filled in if the status of the trouble case is equal to 'Pending', 'Resolved' or 'Completed' or if the status is equal to 'Closed' or 'Cancelled' and the status reason has been indicated during data acquisition.</p> |
| Customer Trouble Case ID   | Shows the internal identification reported by the Customer itself when opening the ticket.  |

**Action Buttons**

| Trouble Case – Search/List |   |
|----------------------------|---|
| Public Trouble Case        | Shows whether the trouble is public from the possible values:<br><br><input type="checkbox"/> Yes<br><input type="checkbox"/> Broadcast   |
| Party BIC                  | It shows the party BIC of the system entity for which the ticket was open.  |
| Action Buttons             |   |
| Select All                 | This function enables you to select all values from the related list.   |
| DeSelect All               | This function enables you to deselect all values from the related list.   |
| Search                     | This function enables you to start a search according to the criteria entered. The results are displayed in a list on the same screen.<br><br>Next screen:<br><input type="checkbox"/> <i>Trouble case – search/list</i> screen<br><br>Reference for error message [▶ 1124]:<br><input type="checkbox"/> ARERR10000 |
| Cancel                     | This function enables you to cancel the process and set all search fields to default value.<br><br>Next screen:<br><input type="checkbox"/> <i>Trouble case – search/list</i> screen  |
| Export                     | This function enables you to export the search result with all the appropriately visible fields as a report.<br><br>Next screen:<br><input type="checkbox"/> <i>Trouble case - export</i> screen [▶ 798]  |
| Details                    | This function enables you to display the details of the selected trouble case.<br><br>Next screen:<br><input type="checkbox"/> <i>Trouble case – details</i> screen [▶ 792]   |

## 4.2.2 Trouble Case - Details Screen

**Context of Usage**

This screen displays detailed information on a trouble case.



**Screen Access**  *Trouble case – list* screen >> Click on the *details* button

**References** **User Instructions Part**

This screen is part of the following business scenario:

*View trouble case* [▶ 805]

**Screenshot**

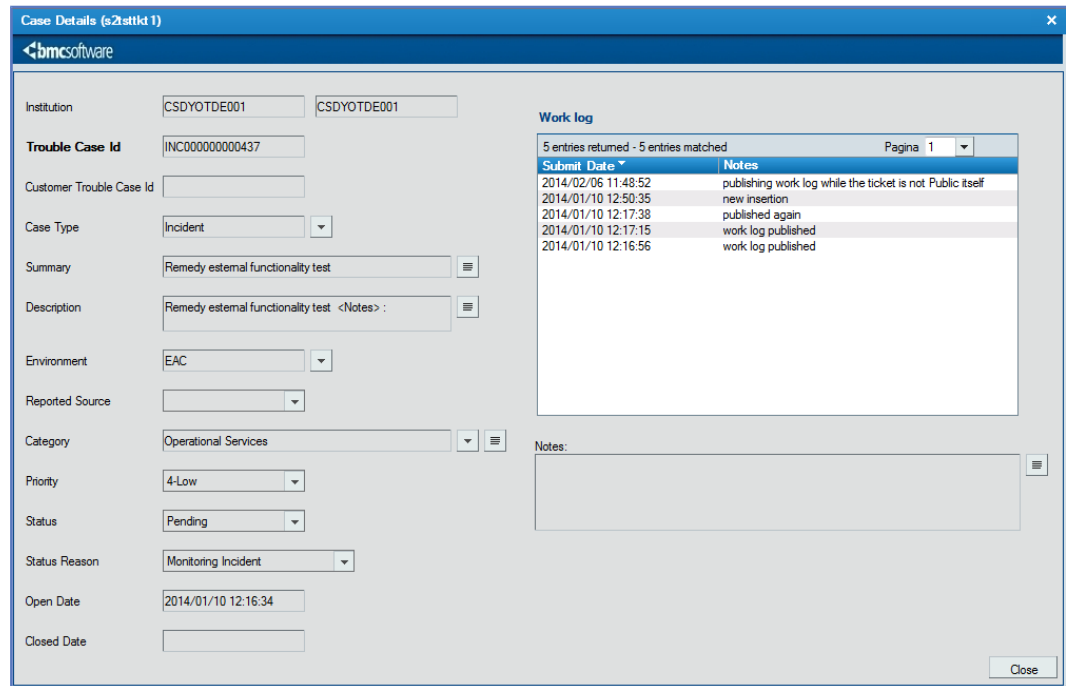

Illustration 132: Trouble case – details screen

**Field Description**

| Case Details             |   |
|--------------------------|---|
| Institution              | Shows the parent BIC and party BIC related to the trouble case.   |
| Trouble Case ID          | Shows the alphanumeric number of the trouble case assigned by the system.<br><br>Note: In case of incidents and requests, the Trouble Case ID always starts with 'INC'. In case of problems the Trouble Case ID always starts with 'PBI'. |
| Customer Trouble Case ID | Shows the alphanumeric identification of the trouble case reported by the customer when opening the ticket.   |
| Case Type                | Shows the case type of the trouble case from the possible values:<br><br><input type="checkbox"/> Incident<br><input type="checkbox"/> Problem<br><input type="checkbox"/> Request  |
| Summary                  | Shows a brief summary of the trouble case.  |

| Case Details    |  |
|-----------------|--|
| Description     | Shows in addition to a brief summary also a detailed description of the trouble case.  |
| Environment     | Shows the environment related to the trouble case from one of the possible values for L2 tickets (other possible internal environment are although present in the search functionalities for this field): <ul style="list-style-type: none"> <li><input type="checkbox"/> Production</li> <li><input type="checkbox"/> Customer</li> <li><input type="checkbox"/> EAC</li> <li><input type="checkbox"/> MIG1</li> <li><input type="checkbox"/> MIG2</li> </ul>   |
| Reported Source | Shows the method the trouble case has been reported from one of the possible values: <ul style="list-style-type: none"> <li><input type="checkbox"/> Direct Input</li> <li><input type="checkbox"/> Email</li> <li><input type="checkbox"/> External Escalation</li> <li><input type="checkbox"/> Fax</li> <li><input type="checkbox"/> Phone</li> <li><input type="checkbox"/> Voice Mail</li> <li><input type="checkbox"/> Other</li> </ul> <p>This field is only filled in if the reporting method has been indicated during data acquisition of the trouble case.</p>  |
| Category        | Shows the category the trouble case is assigned to from the possible values: <ul style="list-style-type: none"> <li><input type="checkbox"/> ALL OR MULTIPLE MODULES</li> <li><input type="checkbox"/> Infrastructure</li> <li><input type="checkbox"/> Interface</li> <li><input type="checkbox"/> Lifecycle Management (LCMM)</li> <li><input type="checkbox"/> Liquidity Management</li> <li><input type="checkbox"/> Migration Tools</li> <li><input type="checkbox"/> Operational Services</li> <li><input type="checkbox"/> SECURITY REQUEST</li> <li><input type="checkbox"/> Settlement</li> <li><input type="checkbox"/> Reference Data Management</li> </ul> |

| Case Details  |   |
|---------------|---|
|               | <ul style="list-style-type: none"> <li><input type="checkbox"/> Statistics, Reports, Queries and Archive</li> <li><input type="checkbox"/> UNKNOWN OR NO MODULES</li> </ul>   |
| Priority      | <p>Shows the priority of the trouble case from the possible values:</p> <ul style="list-style-type: none"> <li><input type="checkbox"/> 4-Low</li> <li><input type="checkbox"/> 3-Medium</li> <li><input type="checkbox"/> 2-Urgent</li> <li><input type="checkbox"/> 1-Critical</li> </ul>   |
| Status        | <p>Shows the current status of the trouble case.</p> <p>If the type of trouble case is set to 'Incident', this field shows the status from the possible values:</p> <ul style="list-style-type: none"> <li><input type="checkbox"/> Assigned</li> <li><input type="checkbox"/> In Progress</li> <li><input type="checkbox"/> Pending</li> <li><input type="checkbox"/> Resolved</li> <li><input type="checkbox"/> Closed</li> <li><input type="checkbox"/> Cancelled</li> </ul> <p>If the type of trouble case is set to 'Problem', this field shows the status from the possible values:</p> <ul style="list-style-type: none"> <li><input type="checkbox"/> Under Review</li> <li><input type="checkbox"/> Assigned</li> <li><input type="checkbox"/> Under Investigation</li> <li><input type="checkbox"/> Pending</li> <li><input type="checkbox"/> Completed</li> <li><input type="checkbox"/> Closed</li> <li><input type="checkbox"/> Cancelled</li> </ul> |
| Status Reason | <p>Shows the reason for the current status of the trouble case.</p> <p>If the status of the trouble case is set to 'Pending', this field shows the reason from the possible values:</p> <ul style="list-style-type: none"> <li><input type="checkbox"/> Automated Resolution Reported</li> <li><input type="checkbox"/> Client Hold</li> <li><input type="checkbox"/> Client Action Required</li> </ul>   |

| Case Details |   |
|--------------|---|
|              | <ul style="list-style-type: none"> <li><input type="checkbox"/> Support Contact Hold</li> <li><input type="checkbox"/> Local Site Action Required</li> <li><input type="checkbox"/> Purchase Order Approval</li> <li><input type="checkbox"/> Registration Approval</li> <li><input type="checkbox"/> Supplier Delivery</li> <li><input type="checkbox"/> Third Party Vendor Action Required</li> <li><input type="checkbox"/> Infrastructure Change (only if Case Type is set to 'Problem')</li> <li><input type="checkbox"/> Pending Original Problem (only if Case Type is set to 'Problem')</li> <li><input type="checkbox"/> Request</li> <li><input type="checkbox"/> Monitoring Incident</li> <li><input type="checkbox"/> Monitoring Problem (only if Case Type is set to 'Problem')</li> <li><input type="checkbox"/> Future Enhancement</li> </ul> <p>If the status of the trouble case is set to 'Resolved', this field shows the reason from the possible values:</p> <ul style="list-style-type: none"> <li><input type="checkbox"/> Automated Resolution Reported</li> <li><input type="checkbox"/> Customer Follow-Up Required</li> <li><input type="checkbox"/> Temporary Corrective Action</li> <li><input type="checkbox"/> Future Enhancement</li> <li><input type="checkbox"/> Monitoring Incident</li> <li><input type="checkbox"/> No Further Action Required</li> </ul> <p>If the status of the trouble case is set to 'Closed', this field shows the reason from the possible values:</p> <ul style="list-style-type: none"> <li><input type="checkbox"/> Successful</li> <li><input type="checkbox"/> Successful with Problem</li> <li><input type="checkbox"/> Unsuccessful</li> <li><input type="checkbox"/> (Empty)</li> </ul> <p>If the status of the trouble case is set to 'Completed', this field shows the reason from the possible values:</p> <ul style="list-style-type: none"> <li><input type="checkbox"/> Known Error</li> <li><input type="checkbox"/> Solution Database</li> </ul> |

| Case Details  |  |
|---|--|
|   | <ul style="list-style-type: none"> <li><input type="checkbox"/> Enhancement Request</li> <li><input type="checkbox"/> Unresolvable</li> </ul> <p>If the status of the trouble case is set to 'Cancelled', this field shows the reason from the possible values:</p> <ul style="list-style-type: none"> <li><input type="checkbox"/> No longer a Causal CI (only if Case Type is set to 'Incident')</li> <li><input type="checkbox"/> Duplicate Investigation (only if Case Type is set to 'Problem')</li> <li><input type="checkbox"/> Not a Defect</li> <li><input type="checkbox"/> (Empty)</li> </ul> <p>This field is only filled in if the status of the trouble case is equal to 'Pending', 'Resolved' or 'Completed' or if the status is equal to 'Closed' or 'Cancelled' and the status reason has been indicated during data acquisition.</p> |
| Open Date   | <p>Shows the date and time of the opening of the trouble case.</p> <p>Displayed format is: YYYY/MM/DD hh:mm:ss</p>   |
| Closed Date   | <p>Shows the date and time of the closure of the trouble case.</p> <p>Displayed format is: YYYY/MM/DD hh:mm:ss</p>   |
| <b>Work Log (Customer relevant information entered by the T2S operator are shown)</b> |  |
| Submit Date   | <p>Shows date and time when the information present in the Work log-Notes is entered.</p> <p>Displayed format is: YYYY/MM/DD hh:mm:ss</p>  |
| Notes   | <p>Shows the work log information added to the trouble case by the T2S operator. Each entry is displayed in a different row and can be selected for complete display in the bottom 'Notes' dedicated area.</p>   |
| Action Buttons  |  |
| Close   | <p>This function enables you to close the <i>details</i> screen and return to the previous screen.</p> <p>Next screen:</p> <ul style="list-style-type: none"> <li><input type="checkbox"/> <i>Trouble case list</i> screen [ ▶ 786]</li> </ul>   |

### 4.2.3 Trouble Case - Export Screen

**Context of Usage** This screen enables you to export your trouble cases as a report (PDF, Power-Point, Word, PostScript or Excel) or to print a report.

**Screen Access**  *Trouble case – list* screen >> Click on the *report* button

**References** **User Instructions Part**

This screen is part of the following business scenario:

Execute a report [▶ 805]

**Screenshot**

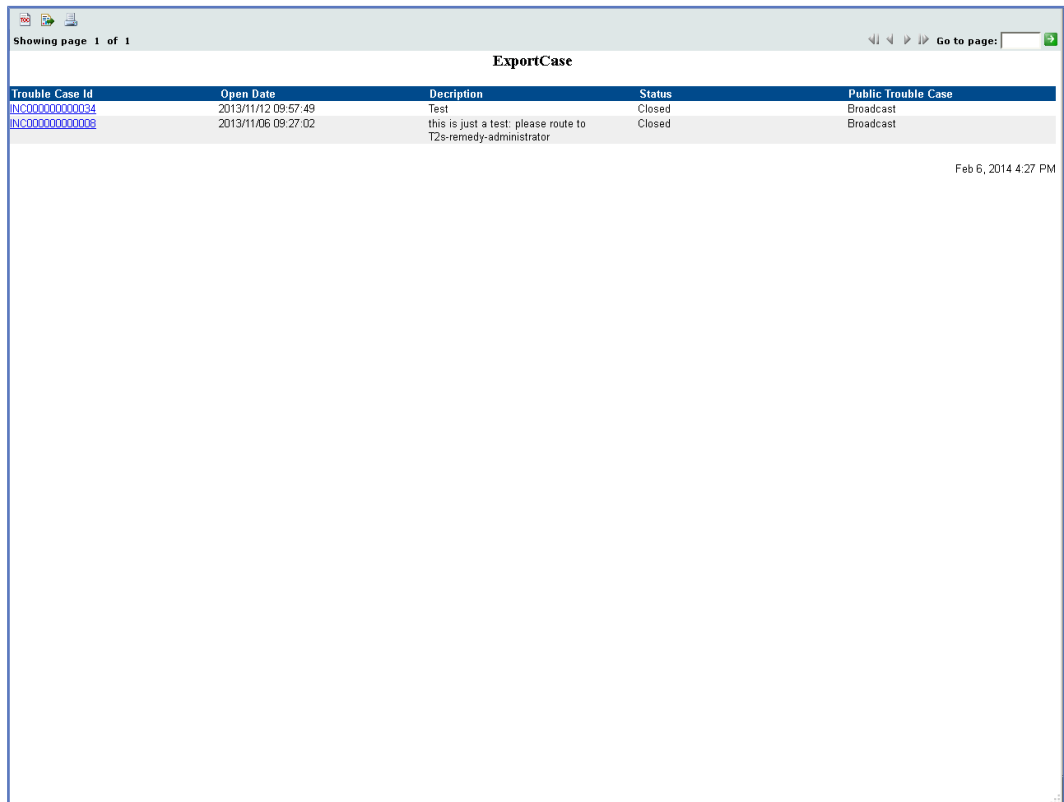

| Trouble Case Id | Environment | Priority | Open Date           | Description   | Status      | Status Reason                 | Customer Trouble Case Id | Public Trouble Case | Party BIC   |
|-----------------|-------------|----------|---------------------|---|-------------|-------------------------------|--------------------------|---------------------|-------------|
| INC000000001348 | Driving     | 4-Low    | 2014/03/14 18:17:14 | Test Admin 2  | Closed      |                               |                          | Broadcast           | 0000000001  |
| INC000000000660 | EAC         | 4-Low    | 2014/01/23 16:16:32 | test of external interface <Notes> : test of external interface   | Closed      | Automated Resolution Reported |                          | Yes                 | CSDYOTDE001 |
| INC000000000670 | EAC         | 4-Low    | 2014/01/17 17:06:39 | test of external interface <Notes> : test of external interface   | Closed      | Successful                    | 123456                   | Yes                 | CSDYOTDE001 |
| INC000000000639 | EAC         | 2-Urgent | 2014/01/16 15:07:40 | Cash > Liquidity > Data Changes > Data Change Details screen<br>UZA<br>BIC AGBLLT2XXXX<br>User PB-AGBLLT2X-2<br><br>Description :<br>Business Validation:<br>Accepted liquidity transfer<br>Execution: full execution, 4-eyes-principle, 1. User<br><br>Detailed Trigger:<br>must use an<br><Notes> : LOT1 - LQMG-LT-284-15-1 - Approval screen not showing all details | Closed      | Successful                    | 143                      | Yes                 | CSDYOTDE001 |
| INC000000000437 | EAC         | 4-Low    | 2014/01/10 12:16:34 | Remedy external functionality test <Notes> :  | Pending     | Monitoring Incident           |                          | Yes                 | CSDYOTDE001 |
| INC000000000414 | IAC         | 4-Low    | 2014/01/09 14:14:18 | Testing External interface of TMS <Notes> :<br>Description :<br>I am testing the External TMS interface entering Public visibility  | In Progress |                               |                          | Yes                 | CSDPOTDE001 |
| INC000000000034 | EAC         | 4-Low    | 2013/11/12 09:57:49 | Test  | Closed      |                               |                          | Broadcast           |             |
| INC000000000008 | Development | 4-Low    | 2013/11/06 09:27:02 | this is just a test, please route to T2s-remedy-administrator   | Closed      |                               |                          | Broadcast           |             |

Illustration 133: Trouble case – export screen

**Field Description**

| Customer Type   |  |
|-----------------|--|
| System Entity   | Shows the system entity your user belongs to.  |
| Parent BIC      | Shows the parent BIC of your party.  |
| Party BIC       | Shows all the possible party BIC related to the parent BIC.  |
| Search Criteria |  |
| Trouble Case ID | Field where it is possible to enter a trouble case ID number of the T2S TMS for single search (available both for problems and incidents).   |
| Status          | Select the status of the trouble case.<br><br>If the type of trouble case is set to 'Incident', select the status of the trouble case from one of the possible values:<br><br><input type="checkbox"/> Assigned<br><input type="checkbox"/> In Progress<br><input type="checkbox"/> Pending<br><input type="checkbox"/> Resolved<br><input type="checkbox"/> Closed<br><input type="checkbox"/> Cancelled<br><input type="checkbox"/> All Open |

| Customer Type |   |
|---------------|---|
|               | <input type="checkbox"/> (Empty) (default value no filter will be applied )<br>If the type of trouble case is set to 'Problem', select the status of the trouble case from one of the possible values:<br><input type="checkbox"/> Under Review<br><input type="checkbox"/> Request for Authorization<br><input type="checkbox"/> Assigned<br><input type="checkbox"/> Under Investigation<br><input type="checkbox"/> Pending<br><input type="checkbox"/> Completed<br><input type="checkbox"/> Rejected<br><input type="checkbox"/> Closed<br><input type="checkbox"/> Cancelled<br><input type="checkbox"/> All Open<br><input type="checkbox"/> (Empty) (default value no filter will be applied) |
| Environment   | Select the environment of the trouble case.<br><input type="checkbox"/> Production<br><input type="checkbox"/> Customer<br><input type="checkbox"/> INTEG<br><input type="checkbox"/> Driving<br><input type="checkbox"/> Development<br><input type="checkbox"/> IAC<br><input type="checkbox"/> EAC<br><input type="checkbox"/> MIG1<br><input type="checkbox"/> MIG2<br><input type="checkbox"/> UTEST<br><input type="checkbox"/> (Empty) (default value no filter will be applied)   |
| Priority      | Select the priority of the trouble case.<br><input type="checkbox"/> 1 – Critical<br><input type="checkbox"/> 2 – Urgent<br><input type="checkbox"/> 3 – Medium<br><input type="checkbox"/> 4 – Low<br><input type="checkbox"/> (Empty) (default value no filter will be applied)   |



| Customer Type         |   |
|-----------------------|---|
| Type of Trouble Case* | <p>Select the type of trouble case from the possible values:</p> <ul style="list-style-type: none"> <li><input type="checkbox"/> Incident (default value)</li> <li><input type="checkbox"/> Problem</li> </ul> <p>Note: Case type = Request is classified as type of trouble case = Incident (further distinction available in the 'Trouble Cases part').</p>   |
| From                  | <p>Enter the lower bound of the search range for the date and time from which the trouble case is opened or use the <i>calendar</i> icon.</p> <p>Required format is YYYY/MM/DD hh:mm:ss</p> <p>The 'From' date and time must be a valid date earlier than or equal to the current business and earlier than or equal to the 'To' date and time.</p> <p>Reference for error message: [<input type="checkbox"/> 1124]</p> <ul style="list-style-type: none"> <li><input type="checkbox"/> ARERR10000</li> </ul> |
| To                    | <p>Enter the upper bound of the search range for the date and time until which the trouble case is opened or use the <i>calendar</i> icon.</p> <p>Required format is: YYYY/MM/DD hh:mm:ss</p> <p>The 'To' date and time must be a valid date later than or equal to the 'From' date and time.</p> <p>Reference for error message: [<input type="checkbox"/> 1124]</p> <ul style="list-style-type: none"> <li><input type="checkbox"/> ARERR10000</li> </ul>   |
| Customer              | <p>Select the party BIC related to your system entity you want to include in your search result.</p> <p>You can select more than one related party BIC.</p>   |
| Trouble Cases         |   |
| Trouble Case ID       | <p>Shows the alphanumeric number of the trouble case assigned by the system.</p> <p>Note: In case of incidents and requests, the trouble case ID always starts with 'INC'. In case of problems the trouble case ID always starts with 'PBI'.</p>  |
| Environment           | Shows the environment chosen for the ticket. Normally it is the environment where the issue was detected.   |
| Priority              | Shows the priority assigned to the ticket.  |

| Customer Type |  |
|---------------|--|
| Open Date     | Shows the date and time the trouble case has been opened.<br>Displayed format is: YYYY/MM/DD hh:mm:ss  |
| Description   | Shows the description of the trouble case.   |
| Status        | Shows the current status of the trouble case.<br>If the type of trouble case is set to 'Incident', this field shows one of the possible values: <ul style="list-style-type: none"> <li><input type="checkbox"/> Assigned</li> <li><input type="checkbox"/> In Progress</li> <li><input type="checkbox"/> Pending</li> <li><input type="checkbox"/> Resolved</li> <li><input type="checkbox"/> Closed</li> <li><input type="checkbox"/> Cancelled</li> <li><input type="checkbox"/> All Open</li> <li><input type="checkbox"/> (Empty) (default value no filter will be applied)</li> </ul> If the type of trouble case is set to 'Problem', this field shows one of the possible values: <ul style="list-style-type: none"> <li><input type="checkbox"/> Under Review</li> <li><input type="checkbox"/> Request for Authorization</li> <li><input type="checkbox"/> Assigned</li> <li><input type="checkbox"/> Under Investigation</li> <li><input type="checkbox"/> Pending</li> <li><input type="checkbox"/> Completed</li> <li><input type="checkbox"/> Rejected</li> <li><input type="checkbox"/> Closed</li> <li><input type="checkbox"/> Cancelled</li> <li><input type="checkbox"/> All Open</li> <li><input type="checkbox"/> (Empty) (default value no filter will be applied)</li> </ul> |
| Status Reason | Shows the reason for the current status of the trouble case.<br>If the status of the trouble case is set to 'Pending', this field shows the reason from the possible values: <ul style="list-style-type: none"> <li><input type="checkbox"/> Automated Resolution Reported</li> </ul>  |

| Customer Type |  |
|---------------|--|
|               | <ul style="list-style-type: none"> <li><input type="checkbox"/> Client Hold</li> <li><input type="checkbox"/> Client Action Required</li> <li><input type="checkbox"/> Support Contact Hold</li> <li><input type="checkbox"/> Local Site Action Required</li> <li><input type="checkbox"/> Purchase Order Approval</li> <li><input type="checkbox"/> Registration Approval</li> <li><input type="checkbox"/> Supplier Delivery</li> <li><input type="checkbox"/> Third Party Vendor Action Required</li> <li><input type="checkbox"/> Infrastructure Change (only if Case Type is set to 'Problem')</li> <li><input type="checkbox"/> Pending Original Problem (only if Case Type is set to 'Problem')</li> <li><input type="checkbox"/> Request</li> <li><input type="checkbox"/> Monitoring Incident</li> <li><input type="checkbox"/> Monitoring Problem (only if Case Type is set to 'Problem')</li> <li><input type="checkbox"/> Future Enhancement</li> </ul> <p>If the status of the trouble case is set to 'Resolved', this field shows the reason from the possible value:</p> <ul style="list-style-type: none"> <li><input type="checkbox"/> Automated Resolution Reported</li> <li><input type="checkbox"/> Customer Follow-Up Required</li> <li><input type="checkbox"/> Temporary Corrective Action</li> <li><input type="checkbox"/> Future Enhancement</li> <li><input type="checkbox"/> Monitoring Incident</li> <li><input type="checkbox"/> No Further Action Required</li> </ul> <p>If the status of the trouble case is set to 'Closed', this field shows the reason from the possible values:</p> <ul style="list-style-type: none"> <li><input type="checkbox"/> Successful</li> <li><input type="checkbox"/> Successful with Problem</li> <li><input type="checkbox"/> Unsuccessful</li> <li><input type="checkbox"/> (Empty)</li> </ul> <p>If the status of the trouble case is set to 'Completed', this field shows the reason from the possible values:</p> |

| Customer Type            |   |
|--------------------------|---|
|                          | <ul style="list-style-type: none"> <li><input type="checkbox"/> Known Error</li> <li><input type="checkbox"/> Solution Database</li> <li><input type="checkbox"/> Enhancement Request</li> <li><input type="checkbox"/> Unresolvable</li> </ul> <p>If the status of the trouble case is set to 'Cancelled', this field shows the reason from the possible values:</p> <ul style="list-style-type: none"> <li><input type="checkbox"/> No longer a Causal CI (only in case of incident/request Ticket)</li> <li><input type="checkbox"/> Duplicate Investigation (only if case type is set to 'Problem')</li> <li><input type="checkbox"/> Not a Defect (only in case of problem tickets)</li> <li><input type="checkbox"/> (Empty)</li> </ul> <p>This field is only filled in if the status of the trouble case is equal to 'Pending', 'Resolved' or 'Completed' or if the status is equal to 'Closed' or 'Cancelled' and the status reason has been indicated during data acquisition.</p> |
| Customer Trouble Case ID | Shows the internal identifier reported by the Customer itself when opening the ticket   |
| Public Trouble Case      | Shows whether the trouble case is public, i.e. only visible to the related system entity of the party BIC, or visible to all parties from the possible values: <ul style="list-style-type: none"> <li><input type="checkbox"/> Yes</li> <li><input type="checkbox"/> Broadcast</li> </ul>   |
| Party BIC                | It shows the party BIC of the system entity for which the ticket was opened.  |

**Buttons**

All available buttons in this screen are related to your browser used and therefore not described in this chapter.

## 4.3 User Instructions Part

### 4.3.1 Monitoring of a Trouble Case

**Overview**

This business package describes the monitoring of a trouble case. To monitor a trouble case, carry out the business scenarios relevant to you from the list below.

**Business Scenarios**

- View trouble case [▶ 805]
- Execute a report [▶ 805]

### 4.3.1.1 View Trouble Case

|                         |   |
|-------------------------|---|
| <b>Context of Usage</b> | This business scenario describes how to view trouble cases related to your system entity, trouble cases opened upon request of parties related to your system entity and in addition trouble cases of general importance visible to all parties. Viewing a trouble case is one option of monitoring of a trouble case.  |
| <b>References</b>       | Further information on screens involved can be found in the screen reference part: <ul style="list-style-type: none"><li><input type="checkbox"/> <i>Trouble case – search/list</i> screen [▶ 786]</li><li><input type="checkbox"/> <i>Trouble case – details</i> screen [▶ 792]</li></ul>  |
| <b>Instructions</b>     | <ol style="list-style-type: none"><li>1. Go to the <i>trouble case – search/list</i> screen.</li><li>2. Depending on your system entity you will see a list of available parties (system entity and party BIC) to be included in your search. Select at least 1 of the displayed Party BICs.</li><li>3. Enter all search criteria known to you about the trouble case you want to view.</li><li>4. Click on the <i>search</i> button.<ul style="list-style-type: none"><li>⇒ A list containing the search results is displayed on the screen.</li></ul></li><li>5. Select the trouble case you would like to display in detail.</li><li>6. Click on the <i>details</i> button.<ul style="list-style-type: none"><li>➔ The details of the selected ticket are displayed.</li></ul></li></ol> |

### 4.3.1.2 Execute a Report

|                         |  |
|-------------------------|--|
| <b>Context of Usage</b> | This business scenario describes how to execute and export or print a report on trouble cases related to your system entity, trouble cases opened by parties related to your system entity and in addition trouble cases broadcasted to all parties. <p>Executing a report is 1 option of monitoring of trouble cases.</p> |
| <b>Privileges</b>       | To carry out this business scenario, you need the following privilege: <ul style="list-style-type: none"><li><input type="checkbox"/> TMS Access</li></ul>   |
| <b>References</b>       | Further information on screens involved can be found in the screen reference part: <ul style="list-style-type: none"><li><input type="checkbox"/> <i>Trouble case – search/list</i> screen [▶ 786]</li><li><input type="checkbox"/> <i>Trouble case – export</i> screen [▶ 798]</li></ul>                                  |
| <b>Instructions</b>     | <ol style="list-style-type: none"><li>1. Go to the <i>trouble case – search/list</i> screen.</li><li>2. Click on the <i>search</i> button.</li></ol>   |



### Hint

You can also restrict your search results by inputting the relevant search parameters.

⇒ A list containing the search results is displayed on the bottom part of the screen.

3. Select the trouble cases to be included in your report (clicking on each of the 'column name fields' allows ordering the list in ascending or descending order for the selected column).



### Alternative action

Click on the *select all* button to include all trouble cases from the list.

4. Click on the *export* button.

⇒ The *trouble case - export* screen is displayed.



### Note

Depending on your browser used and local settings the buttons to be used to export or print a report and the further steps may differ. In the following example Mozilla Firefox has been used.

5. Click on the *export report* button.



⇒ The export report window of your browser is opened.

6. Select the export format and in case of need the pages of the report to be exported. Possible format are: PDF, Power Point, Word, Post Script and Excel.

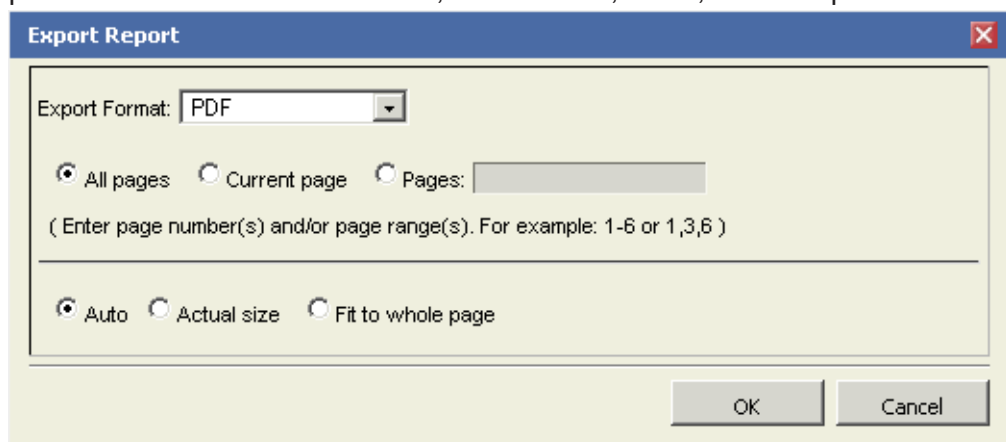

7. Click on the *ok* button.

⇒ The standard download window of your browser is opened.

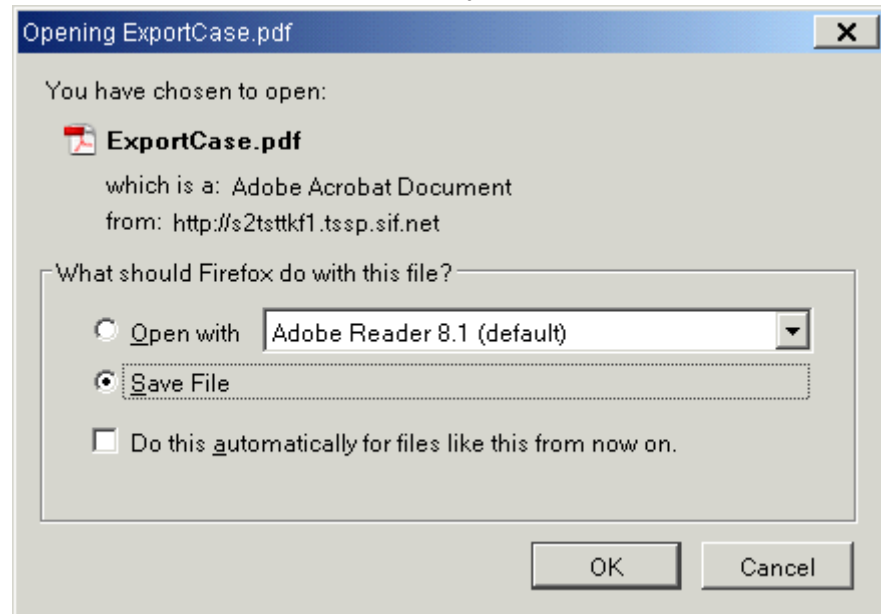

8. Click on the **OK** button.

➔ The report is downloaded and saved in the standard download folder of your browser.

## 5 Annex

### 5.1 Indication of Usage

#### 5.1.1 Reader's Guide

##### Reader's Guide

This part of the annex is divided into screens and business scenarios, both in alphabetical order. For each screen description and business scenario, you can find an indication of the primary user (CB / CSD). This indication is not binding.

#### 5.1.2 Usage Indication

##### Screens

| Screen  | Usage Indication (CSD/ CB) |
|---|----------------------------|
| Allegation Instruction - Details Screen [▶ 93]  | CSD                        |
| Allegation Instructions - Search/List Screen [▶ 89]   | CSD                        |
| Amendment Cash Instruction - Details Screen [▶ 404]   | CB                         |
| Amendment Cash Instruction - New Screen [▶ 409]   | CB                         |
| Amendment Securities Instruction - Details Screen [▶ 97]  | CSD                        |
| Amendment Securities Instruction - New Screen [▶ 102]   | CSD                        |
| Attribute Domain - Details Screen   | CSD/CB                     |
| Attribute Domain - New/Edit Screen  | CSD/CB                     |
| Attribute Domain Reference - Details Screen   | CSD/CB                     |
| Attribute Domain Reference - New/Edit Screen  | CSD/CB                     |
| Attribute Domain References - List Screen   | CSD/CB                     |
| Attribute Domains - Search/List Screen  | CSD/CB                     |
| Auto-Collateralisation Eligibility Link - New Screen  | CB                         |
| Auto-Collateralisation Eligibility Links - Search/List Screen   | CB                         |
| Available Report - Current Settlement Day Cash Information (Following Settlement Day Cash Forecast) Report - Details Screen [▶ 458] | CB                         |
| Available Report – Daily Penalty List – Details Screen [▶ 573]  | CSD                        |
| Available Report - Details Screen [▶ 456]   | CSD/CB                     |



| Screen  | Usage Indication (CSD/ CB) |
|---|----------------------------|
| Available Report – List of Modified Penalties - Details Screen [ ▶ 587]   | CSD                        |
| Available Report – Monthly Aggregated Amounts – Details Screen [ ▶ 602]   | CSD                        |
| Available Report - Statement of Accounts - Details Screen [ ▶ 463]  | CB                         |
| Available Report - Statement of Executed Amendment Instructions for Intra-Balance Movements - Details Screen [ ▶ 466]                                 | CB                         |
| Available Report - Statement of Executed Amendment Instructions for Intra-Position Movements and Settlement Instructions - Details Screen [ ▶ 471]    | CSD                        |
| Available Report - Statement of Executed Cancellation Instructions for Intra-Balance Movements - Details Screen [ ▶ 480]                              | CB                         |
| Available Report - Statement of Executed Cancellation Instructions for Intra-Position Movements and Settlement Instructions - Details Screen [ ▶ 484] | CSD                        |
| Available Report - Statement of Holdings - Details Screen [ ▶ 492]  | CSD                        |
| Available Report - Statement of Pending Amendment Instructions for Intra-Balance Movements - Details Screen [ ▶ 497]                                  | CB                         |
| Available Report - Statement of Pending Amendment Instructions for Intra-Position Movements and Settlement Instructions - Details Screen [ ▶ 502]     | CSD                        |
| Available Report - Statement of Pending Cancellation Instructions for Intra-Balance Movements - Details Screen [ ▶ 511]                               | CB                         |
| Available Report - Statement of Pending Cancellation Instructions for Intra-Position Movements and Settlement Instructions - Details Screen [ ▶ 515]  | CSD                        |
| Available Report - Statement of Pending Instructions - Details Screen [ ▶ 523]  | CSD                        |
| Available Report - Statement of Pending Intra-Balance Movements - Details Screen [ ▶ 532]   | CB                         |

| Screen   | Usage Indication (CSD/ CB) |
|--|----------------------------|
| Available Report - Statement of Pending Intra-Position Movements - Details Screen [ ▶ 537] | CSD                        |
| Available Report - Statement of Settled Intra-Balance Movements - Details Screen [ ▶ 542]  | CB                         |
| Available Report - Statement of Settled Intra-Position Movements - Details Screen [ ▶ 547] | CSD                        |
| Available Report - Statement of Settlement Allegements - Details Screen [ ▶ 550]           | CSD                        |
| Available Report - Statement of Transactions - Details Screen [ ▶ 563]                     | CSD                        |
| Available Reports - Statement of Common Reference Data details Screen                      | CSD/CB                     |
| Available Reports – Details Screen   | CSD/CB                     |
| Available Reports - Search/List Screen [ ▶ 451]  | CSD/CB                     |
| BIC Directory Items - Search/List Screen   | CSD/CB                     |
| Broadcast - Details Screen [ ▶ 619]  | CSD/CB                     |
| Broadcast - New Screen [ ▶ 621]  | CSD/CB                     |
| Broadcasts – Search/List Screen [ ▶ 616]   | CSD/CB                     |
| Cancellation Cash Instruction – Details Screen [ ▶ 416]                                    | CB                         |
| Cancellation Cash Instruction – New Screen [ ▶ 419]  | CB                         |
| Cancellation Securities Instruction – Details Screen [ ▶ 112]                              | CSD                        |
| Cancellation Securities Instruction – New Screen [ ▶ 116]                                  | CSD                        |
| Cash Account - Details Screen  | CSD/CB                     |
| Cash Account – New/Edit Screen   | CSD/CB                     |
| Cash Accounts - Search/List Screen   | CSD/CB                     |
| Cash Discount Penalty Rate - Search/List Screen  | CSD/CB                     |
| Cash Forecast – Details Screen [ ▶ 331]  | CB                         |
| Cash Forecasts – Search/List Screen [ ▶ 323]   | CB                         |
| Cash Restriction Details – Search/List Screen [ ▶ 337]                                     | CB                         |
| Certificate Distinguished Name – New Screen  | CSD/CB                     |

| Screen   | Usage Indication (CSD/<br>CB) |
|--|-------------------------------|
| Certificate Distinguished Names – Search/List Screen                                       | CSD/CB                        |
| Close Link – New Screen  | CB                            |
| Close Links – Search/List Screen   | CSD/CB                        |
| Closing Days- Search/List Screen   | CSD/CB                        |
| Collateral Value of a Security – Search/List Screen [ ▶ 340]                               | CSD/CB                        |
| Collateral Value per T2S Dedicated Cash Account and Security – Search/List Screen [ ▶ 344] | CSD/CB                        |
| Common Reference Data Revisions - Search/List Screen                                       | CSD/CB                        |
| CoSD Rule – New/Edit Screen  | CSD                           |
| CoSD Rule Sets - Details Screen  | CSD                           |
| CoSD Rule Sets – New/Edit Screen   | CB                            |
| CoSD Rule Sets - Search/List Screen  | CSD                           |
| Countries - Search/List Screen   | CSD/CB                        |
| CMB - Details Screen   | CB                            |
| CMB - New/Edit Screen  | CB                            |
| CMBs - Search/List Screen  | CB                            |
| CSD Account Link - New/Edit Screen   | CSD                           |
| CSD Account Links - Search/List Screen   | CSD                           |
| Currencies - Search/List Screen  | CSD/CB                        |
| Daily Price – New/Edit Screen  | CSD                           |
| Daily Price - Search/List Screen   | CSD/CB                        |
| Data Change - Details Screen [ ▶ 611]  | CSD/CB                        |
| Data Changes - Search/List Screen [ ▶ 607]   | CSD/CB                        |
| Eligible Counterpart CSD - Details Screen  | CSD                           |
| Eligible Counterpart CSD - New/Edit Screen   | CSD                           |
| Eligible Counterpart CSDs - Search/List Screen   | CSD                           |
| Euro Foreign Exchange Reference Rate - New/Edit Screen                                     | CB                            |
| Euro Foreign Exchange Reference Rate - Search/<br>List Screen                              | CSD/CB                        |

| Screen   | Usage Indication (CSD/ CB) |
|--|----------------------------|
| Event Type - Details Screen  | CSD/CB                     |
| Event Types - Search/List Screen   | CSD/CB                     |
| External RTGS Account - Details Screen                                     | CB                         |
| External RTGS Account - New/Edit Screen                                    | CB                         |
| External RTGS Accounts - Search/List Screen                                | CB                         |
| Grant/Revoke Cross-System Entity Object Privilege – Details Screen         | CSD/CB                     |
| Grant/Revoke Cross-System Entity Object Privilege – New/Edit Screen        | CSD/CB                     |
| Grant/Revoke Object Privilege – Details Screen                             | CSD/CB                     |
| Grant/Revoke Object Privilege – New/Edit Screen                            | CSD/CB                     |
| Grant/Revoke Privileges – Search/List Screen                               | CSD/CB                     |
| Grant/Revoke Roles – Details Screen  | CSD/CB                     |
| Grant/Revoke Roles – New/Edit Screen                                       | CSD/CB                     |
| Grant/Revoke Roles - Search/List Screen                                    | CSD/CB                     |
| Grant/Revoke System Privilege – Details Screen                             | CSD/CB                     |
| Grant/Revoke System Privilege – New/Edit Screen                            | CSD/CB                     |
| Hold/Release Instruction – Details Screen [ ▶ 121]                         | CSD                        |
| Hold/Release Instruction – New Screen [ ▶ 125]                             | CSD                        |
| Immediate Liquidity Transfer – Details Screen [ ▶ 381]                     | CB                         |
| Immediate Liquidity Transfer – New Screen [ ▶ 386]                         | CB                         |
| Immediate Liquidity Transfer – Search/List Screen [ ▶ 373]                 | CB                         |
| Inbound File – Details Screen [ ▶ 625]                                     | CSD/CB                     |
| Inbound Files – Search/List Screen [ ▶ 622]                                | CSD/CB                     |
| Inbound Message – Details Screen [ ▶ 635]                                  | CSD/CB                     |
| Inbound Messages – Search/List Screen [ ▶ 628]                             | CSD/CB                     |
| Insolvency procedure Settlement Instructions – Search/List Screen [ ▶ 269] | CSD                        |
| Intra-Balance Movement – Details Screen [ ▶ 429]                           | CB                         |
| Intra-Balance Movement – New Screen [ ▶ 436]                               | CB                         |

| Screen  | Usage Indication (CSD/<br>CB) |
|---|-------------------------------|
| Intra-Balance Movements – Search/List Screen<br>[ ▶ 422]                    | CB                            |
| Intra-Position Movement – Details Screen [ ▶ 143]                           | CSD                           |
| Intra-Position Movement – New Screen [ ▶ 150]                               | CSD                           |
| Intra-Position Movements – Search/List Screen<br>[ ▶ 136]                   | CSD                           |
| Limit – New/Edit Screen [ ▶ 347]  | CB                            |
| Limit Utilisation – Search/List Screen [ ▶ 348]                             | CSD/CB                        |
| Limit Utilisation Journal – Search/List Screen<br>[ ▶ 352]                  | CSD/CB                        |
| Limits – Search/List Screen [ ▶ 347]  | CB                            |
| Links Preventing Settlement - List Screen [ ▶ 276]                          |                               |
| Maintenance Cash Instructions – Search/List<br>Screen [ ▶ 447]              | CB                            |
| Maintenance Securities Instructions – Search/List<br>Screen [ ▶ 163]        | CSD                           |
| Market-Specific Attribute – Details Screen                                  | CSD/CB                        |
| Market-Specific Attribute – New/Edit Screen                                 | CSD/CB                        |
| Market-Specific Attributes – Search/List Screen                             | CSD/CB                        |
| Message Subscription Rule – New/Edit Screen                                 | CSD/CB                        |
| Message Subscription Rule Set – Details Screen                              | CSD/CB                        |
| Message Subscription Rule Set – New/Edit Screen                             | CSD/CB                        |
| Message Subscription Rule Sets – Search/List<br>Screen                      | CSD/CB                        |
| Monthly Net Penalty Amounts - Search/List Screen<br>[ ▶ 309]                | CSD                           |
| Network Services – Search/List Screen                                       | CSD/CB                        |
| Outbound File – Details Screen [ ▶ 643]                                     | CSD/CB                        |
| Outbound Files – Search/List Screen [ ▶ 640]                                | CSD/CB                        |
| Outbound Message – Details Screen [ ▶ 653]                                  | CSD/CB                        |
| Outstanding Auto-Collateralisation Credits –<br>Search/List Screen [ ▶ 392] | CSD/CB                        |
| Overall Liquidity – Search/List Screen [ ▶ 396]                             | CB                            |

| Screen   | Usage Indication (CSD/CB) |
|--|---------------------------|
| Partial Settlement Thresholds – Search/List Screen   | CSD/CB                    |
| Parties – Search/List Screen                         | CSD/CB                    |
| Party – Details Screen                               | CSD/CB                    |
| Party – New/Edit Screen                              | CSD/CB                    |
| Penalty - Details Screen [ ▶ 290]                    | CSD                       |
| Penalty - Removal Screen [ ▶ 314]                    | CSD                       |
| Penalty - Search/List Screen [ ▶ 278]                | CSD                       |
| Penalty - Switch Screen [ ▶ 321]                     | CSD                       |
| Privileges – Search/List Screen                      | CSD/CB                    |
| Queued Static Data Changes – Search/List Screen      | CSD/CB                    |
| Queued Static Data Change – Details Screen           | CSD/CB                    |
| Report Configurations - Details Screen               | CSD/CB                    |
| Report Configuration – New/Edit Screen               | CSD/CB                    |
| Report Configurations – Search/List Screen           | CSD/CB                    |
| Resend Communication Screen [ ▶ 657]                 | CSD/CB                    |
| Restricted Parties – Search/List Screen              | CSD/CB                    |
| Restriction Type - Details Screen                    | CSD/CB                    |
| Restriction Type – New/Edit Screen                   | CSD/CB                    |
| Restriction Type Rule – New/Edit Screen              | CSD/CB                    |
| Restriction Types – Search/List Screen               | CSD/CB                    |
| Role – New/Edit Screen                               | CSD/CB                    |
| Roles – Search/List Screen                           | CSD/CB                    |
| Routing – New/Edit Screen                            | CSD/CB                    |
| Routing – Search/List Screen                         | CSD/CB                    |
| Secured Group – Details Screen                       | CSD/CB                    |
| Secured Group – New/Edit Screen                      | CSD/CB                    |
| Secured Groups – Search/List Screen                  | CSD/CB                    |
| Securities – Search/List Screen                      | CSD/CB                    |
| Securities Account – Details Screen                  | CSD                       |
| Securities Account – New/Edit Screen                 | CSD                       |
| Securities Account Transfer Management – Edit Screen | CSD                       |

| Screen  | Usage Indication (CSD/ CB) |
|---|----------------------------|
| Securities Accounts – Search/List Screen  | CSD                        |
| Securities Accounts Links – New/Edit Screen                                     | CSD                        |
| Securities Accounts Links – Search/List Screen                                  | CSD/CB                     |
| Securities Position – Details Screen [ ▶ 173]                                   | CSD                        |
| Securities Positions – Search/List Screen [ ▶ 168]                              | CSD                        |
| Securities Postings – Search/List Screen [ ▶ 81]                                | CSD                        |
| Securities Restriction Details – Search/List Screen [ ▶ 85]                     | CSD                        |
| Securities subject to Cash Penalties – New/Edit Screen                          | CSD                        |
| Securities Subject to Cash Penalties - Search/List Screen                       | CSD/CB                     |
| Securities Valuation – New Screen   | CB                         |
| Securities Valuations – Search/List Screen                                      | CB                         |
| Security – Details Screen   | CSD/CB                     |
| Security – New/Edit Screen  | CSD                        |
| Security CSD Link – Details Screen  | CSD                        |
| Security CSD Link – New/Edit Screen   | CSD                        |
| Security CSD Links – Search/List Screen   | CSD                        |
| Security Penalty Rate - Search/List Screen                                      | CSD/CB                     |
| Service Item – Details Screen   | CSD/CB                     |
| Service Items – Search/List Screen  | CSD/CB                     |
| Settlement Instruction – Details Screen [ ▶ 191]                                | CSD                        |
| Settlement Instruction – New Screen [ ▶ 210]                                    | CSD                        |
| Settlement Instructions – Search/List Screen [ ▶ 176]                           | CSD                        |
| SME Growth Market - Search/List Screen  | CSD/CB                     |
| Standing/Predefined Liquidity Transfer Order – Details Screen [ ▶ 400]          | CB                         |
| Standing/Predefined Liquidity Transfer Order – New/Edit Screen [ ▶ 400]         | CB                         |
| Standing/Predefined Liquidity Transfer Order Link Set – Details Screen [ ▶ 400] | CB                         |

| Screen  | Usage Indication (CSD/ CB) |
|---|----------------------------|
| Standing/Predefined Liquidity Transfer Order Link Set – New/Edit Screen [ ▶ 400]            | CB                         |
| Standing/Predefined Liquidity Transfer Order Link Sets – Search/List Screen [ ▶ 400]        | CB                         |
| Standing/Predefined Liquidity Transfer Orders – Search/List Screen [ ▶ 400]                 | CB                         |
| Status History – Details Screen [ ▶ 266]  | CSD/CB                     |
| System Entities – Search/List Screen  | CSD/CB                     |
| T2S DCA Balance - Details Screen [ ▶ 361]   | CB                         |
| T2S DCA Balances - Search/List Screen [ ▶ 357]  | CB                         |
| T2S DCA Postings - Search/List Screen [ ▶ 363]  | CB                         |
| Technical Addresses Network Services Link - Details Screen                                  | CSD/CB                     |
| Technical Addresses Network Services Link - New/Edit Screen                                 | CSD/CB                     |
| Tolerance Amounts - Search/List Screen  | CSD/CB                     |
| Total Amount of Standing/Predefined Liquidity Transfer Orders - Search/List Screen [ ▶ 400] | CB                         |
| Total collateral value per T2S dedicated cash account - Search/List Screen [ ▶ 369]         | CSD/CB                     |
| User - Details Screen   | CSD/CB                     |
| User – New/Edit Screen  | CSD/CB                     |
| User- Search/List Screen  | CSD/CB                     |
| User Access Rights - List Screen  | CSD/CB                     |
| User Access Rights - Search Screen  | CSD/CB                     |
| User Certificate Distinguished Name Link - New Screen                                       | CSD/CB                     |
| User Certificate Distinguished Name Links - Search/List Screen                              | CSD/CB                     |
| <b>Business Scenarios</b>   |                            |
| Business Scenario   | Usage Indication (CSD/ CB) |
| Add a Link for a Settlement Instruction [ ▶ 703]  | CSD                        |
| Add a Link for a Settlement Restriction on Cash [ ▶ 766]                                    | CB                         |



| Business Scenario  | Usage Indication (CSD/ CB) |
|--|----------------------------|
| Add a Link for a Settlement Restriction on Securities [ ▶ 757]               | CSD                        |
| Add a new Technical Address to a Party                                       | CSD/CB                     |
| Amend the Partial Settlement Indicator for a Settlement Instruction [ ▶ 706] | CSD                        |
| Amend the Priority for a Settlement Instruction [ ▶ 707]                     | CSD                        |
| Amend the Priority for a Settlement Restriction on Cash [ ▶ 768]             | CB                         |
| Amend the Priority for a Settlement Restriction on Securities [ ▶ 760]       | CSD                        |
| Approve an Action in 4-Eyes Mode   | CSD/CB                     |
| Assign a Role to a Party   | CSD/CB                     |
| Assign a Role to a User  | CSD/CB                     |
| Assign a Secured Object to a Secured Group                                   | CSD/CB                     |
| Cancel a Settlement Instruction [ ▶ 727]                                     | CSD                        |
| Cancel a Settlement Restriction on Cash [ ▶ 777]                             | CB                         |
| Cancel a Settlement Restriction on Securities [ ▶ 773]                       | CSD                        |
| Change the Limit of a Payment Bank   | CB                         |
| Configure CSD Account Links  | CSD                        |
| Configure Security CSD Links   | CSD                        |
| Copy a Settlement Instruction [ ▶ 690]                                       | CSD                        |
| Copy a Settlement Restriction on Cash [ ▶ 753]                               | CB                         |
| Copy a Settlement Restriction on Securities [ ▶ 747]                         | CSD                        |
| Copy an Immediate Liquidity Transfer [ ▶ 671]                                | CB/CSD                     |
| Create a new Broadcast   | CSD/CB                     |
| Create a new Credit Memorandum Balance                                       | CB                         |
| Create a new external RTGS Account   | CB                         |
| Create a new Immediate Liquidity Transfer                                    | CSD/CB                     |
| Create a new Liquidity Transfer Order Link Set                               | CB                         |
| Create a new Participant   | CSD/CB                     |
| Create a new Report Configuration  | CSD/CB                     |

| Business Scenario   | Usage Indication (CSD/ CB) |
|---|----------------------------|
| Create a new Role   | CSD/CB                     |
| Create a new Secured Group  | CSD/CB                     |
| Create a new Securities Account   | CSD                        |
| Create a new Securities Valuation   | CB                         |
| Create a new Security   | CSD                        |
| Create a new Standing/Predefined Liquidity Transfer Order                             | CB                         |
| Create a new T2S Dedicated Cash Account   | CB                         |
| Create a new Technical Address Service Link   | CSD/CB                     |
| Create a new User   | CSD/CB                     |
| Create a new User Certificate Distinguished Name                                      | CSD/CB                     |
| Create a new User Certificate Distinguished Name Link                                 | CSD/CB                     |
| Delete an existing Participant  | CSD/CB                     |
| Delete an existing Securities Account   | CSD                        |
| Delete an existing T2S Dedicated Cash Account   | CB                         |
| Edit an existing Participant  | CSD/CB                     |
| Edit an existing Securities Account   | CSD                        |
| Edit an existing T2S Dedicated Cash Account   | CB                         |
| Enter a Settlement Instruction [ ▶ 686]   | CSD                        |
| Enter a Settlement Restriction on Cash [ ▶ 751]                                       | CB                         |
| Enter a Settlement Restriction on Securities [ ▶ 745]                                 | CSD                        |
| Grant a Privilege to a Party  | CSD/CB                     |
| Grant a Privilege to a User   | CSD/CB                     |
| Grant System and Object Privileges to a Role  | CSD/CB                     |
| Initiate an Action in 4-Eyes Mode   | CSD/CB                     |
| Link a Securities Account to a T2S Dedicated Cash Account for Cash Settlement Purpose | CSD                        |
| Put a Settlement Instruction on CSD Hold [ ▶ 715]                                     | CSD                        |
| Put a Settlement Instruction on Party Hold [ ▶ 713]                                   | CSD                        |
| Reimburse an Outstanding Intraday Credit [ ▶ 679]                                     | CSD                        |
| Release a Settlement Instruction from CoSD Hold [ ▶ 722]                              | CSD                        |

| Business Scenario   | Usage Indication (CSD/ CB) |
|---|----------------------------|
| Release a Settlement Instruction from CSD Hold [ ▶ 720]                                   | CSD                        |
| Release a Settlement Instruction from CSD Validation Hold [ ▶ 724]                        | CSD                        |
| Release a Settlement Instruction from Party Hold [ ▶ 717]                                 | CSD                        |
| Remove a Link for a Settlement Instruction [ ▶ 709]                                       | CSD                        |
| Remove a Link for a Settlement Restriction on Cash [ ▶ 770]                               | CB                         |
| Remove a Link for a Settlement Restriction on Securities [ ▶ 762]                         | CSD                        |
| Resend Communication [ ▶ 667]   | CSD/CB                     |
| Respond to an Allegement Instruction [ ▶ 696]   | CSD                        |
| Set up an Auto-Collateralisation Limit  | CB                         |
| View a Broadcast [ ▶ 666]   | CSD/CB                     |
| View Alleged Cancellation Instruction [ ▶ 730]  | CSD                        |
| View Allegement Settlement Instruction Details [ ▶ 702]                                   | CSD                        |
| View Amendment Instruction for a Settlement Instruction Details [ ▶ 711]                  | CSD                        |
| View Amendment Instruction for a Settlement Restriction on Cash Details [ ▶ 772]          | CB                         |
| View Amendment Instruction for a Settlement Restriction on Securities Details [ ▶ 764]    | CSD                        |
| View Available Reports  | CSD/CB                     |
| View Cancellation Instruction for a Settlement Instruction Details [ ▶ 729]               | CSD                        |
| View Cancellation Instruction for a Settlement Restriction on Cash Details [ ▶ 778]       | CB                         |
| View Cancellation Instruction for a Settlement Restriction on Securities Details [ ▶ 775] | CSD                        |
| View Cash Balances Details and Related Postings [ ▶ 673]                                  | CB                         |
| View Cash Balances Details and Related Restrictions [ ▶ 674]                              | CB                         |

| Business Scenario   | Usage Indication (CSD/CB) |
|---|---------------------------|
| View Current Securities Positions and Related Posting [ ▶ 681]s                             | CSD                       |
| View Current Securities Positions and Related Restrictions [ ▶ 682]                         | CSD                       |
| View Historic Securities Positions for a Specific Date [ ▶ 683]                             | CSD                       |
| View Historic Securities Positions for a Specific Period [ ▶ 684]                           | CSD                       |
| View Hold/Release Instruction Details [ ▶ 725]  | CSD                       |
| View Immediate Liquidity Transfer Details [ ▶ 675]  | CSD/CB                    |
| View Inbound Communication [ ▶ 668]   | CSD/CB                    |
| View Outbound Communication [ ▶ 669]  | CSD/CB                    |
| View Overall Liquidity [ ▶ 677]   | CSD/CB                    |
| View Privilege Details  | CSD/CB                    |
| View Revisions  | CSD/CB                    |
| View Settlement Instruction Details [ ▶ 701]  | CSD                       |
| View Settlement Instruction Status History [ ▶ 732]   | CSD                       |
| View Settlement Restriction on Cash Details [ ▶ 756]  | CB                        |
| View Settlement Restriction on Securities Details [ ▶ 750]                                  | CSD                       |
| View SF1/SF2 timestamps of Settlement Instructions in case of Insolvency situation [ ▶ 733] | CB                        |
| View Standing/Predefined Liquidity Transfer Order Details                                   | CSD/CB                    |

## 5.2 Sitemap for T2S GUI

### 5.2.1 Reader's Guide

The sitemap annex is structured along the first and the second GUI menu level. It provides you with a formalised illustration of all screens (pictured as rectangles) and their related buttons (pictured as arrows). The illustration helps you to get an overview of all GUI screens and their interrelation, indicated by the arrows.

**General layout of a sitemap** In general, each sitemap has the same layout. The header of the sitemap always indicates the GUI menu item pictured by the sitemap. The first 3 lines represent the 3 main menu levels.

| Menu Name    |  |
|--------------|--|
| Menu Level 1 |  |
| Menu Level 2 |  |
| Menu Level 3 |  |

Illustration 134: Sitemap menu levels – GUI path

In lines 4 to 6, the single GUI screens are pictured following their business logic, i.e. starting with *search/list* screens in line 4, *details* or *enter* screens in line 5 and finishing with *revisions/audit trail – list* screens in line 6.

|                        |  |
|------------------------|--|
| Search / List Screen   |  |
| Details / Enter Screen |  |
| Revision / Audit Trail |  |

Illustration 135: Sitemap menu levels - screens

Within these lines, regular rectangles represent a menu item, rounded rectangles represent a screen.

| Menu Securities |   |
|-----------------|---|
| Menu Level 1    | <div style="border: 1px solid black; padding: 5px; text-align: center;"> <b>MI</b><br/> <b>Securities</b> </div>  |
| Menu Level 2    | <div style="display: flex; justify-content: space-around;"> <div style="border: 1px solid black; padding: 2px;">MI.1<br/>Securities Account</div> <div style="border: 1px solid black; padding: 2px;">MI.2<br/>Settlement</div> </div>  |
| Menu Level 3    | <div style="display: flex; justify-content: space-between; font-size: small;"> <div style="border: 1px solid black; padding: 2px;">MI.1.1<br/>Securities Positions</div> <div style="border: 1px solid black; padding: 2px;">MI.1.2<br/>Securities Postings</div> <div style="border: 1px solid black; padding: 2px;">MI.1.3<br/>Securities Restriction</div> <div style="border: 1px solid black; padding: 2px;">MI.2.1<br/>Settlement Instructions</div> <div style="border: 1px solid black; padding: 2px;">MI.2.2<br/>Intra-Position Movements</div> <div style="border: 1px solid black; padding: 2px;">MI.2.3<br/>Maintenance Securities Instructions</div> <div style="border: 1px solid black; padding: 2px;">MI.2.4<br/>Settlement Instruction Aligements</div> <div style="border: 1px solid black; padding: 2px;">MI.2.5<br/>Data Changes</div> <div style="border: 1px solid black; padding: 2px;">MI.2.6<br/>Securities Positions</div> </div> |

Illustration 136: Menu item and sitemap screen illustration

**Interrelation between screens** Arrows between the rectangles represent an interrelation, while the button that has to be clicked on to jump from one screen to another is written across the corresponding arrow.

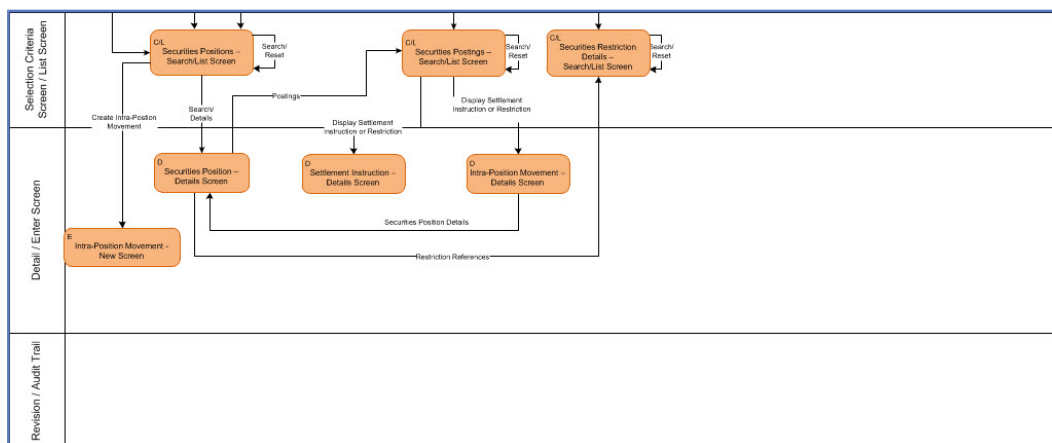

Illustration 137: Screen interrelation

### Menu item and screen rectangles

The screen rectangles follow the same colour-coding as the GUI (see menu structure [▶ 31]). The classification found in the top left corner of each rectangle provides the following detailed information:

- Capital M for menu followed by max. 3 digits indicating the main menu item (1 for securities, 2 for cash, 3 for services, 4 for static data, 5 for monitoring) and following menu levels.
- Screen classification (C/L for *search/list* screen, C for *search* screen, L for *list* screen, D for *details* screen, E for *enter* screen).

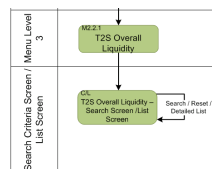

Illustration 138: Sitemap screen with classification and with button

### Screens with a different colour

On some sitemaps you will also find screens illustrated in a different colour than it is foreseen for the respective T2S menu. These particular screens represent an alternative navigation to the same respective screen. These specific screens appear on the same menu level than the regular screens.

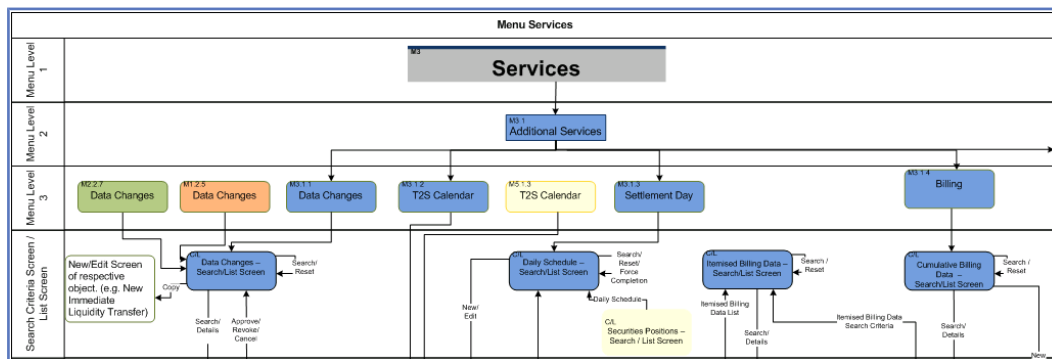

Illustration 139: Screens with a different colour

**Interrelation between sitemap parts**

Because of the size of the sitemap it has been split into several parts. You can recognise the use of several sitemap parts by an arrow leading to the next sitemap part.

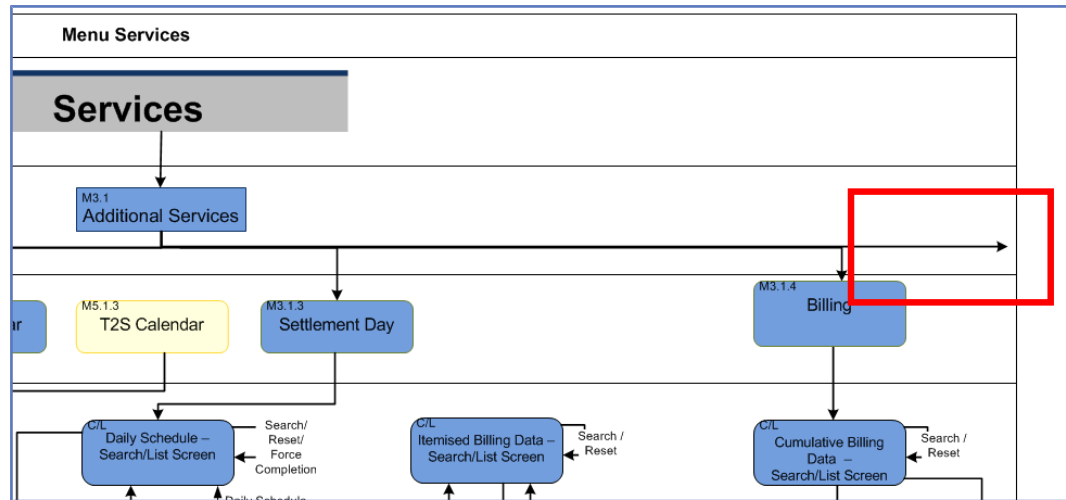

Illustration 140: Sitemap part interrelation

The static data sitemap for example is divided into 14 different sitemaps because of the wealth of information. Therefore it is recommended to read the sitemap from the top to the bottom and then from the left hand-side to the right hand-side.

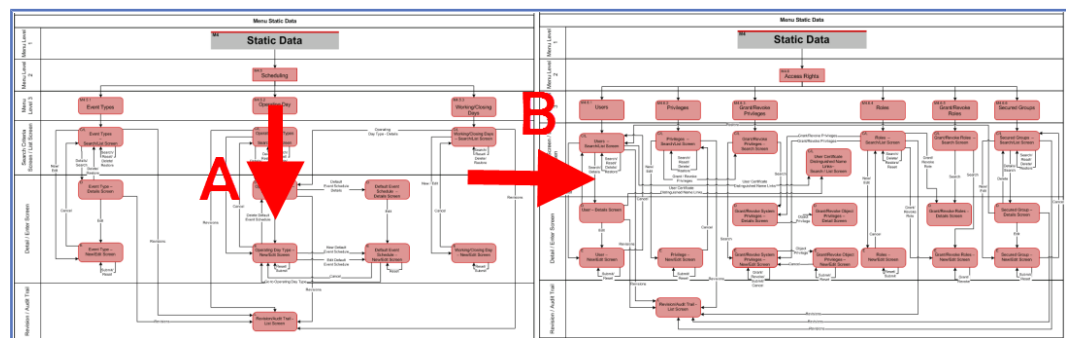
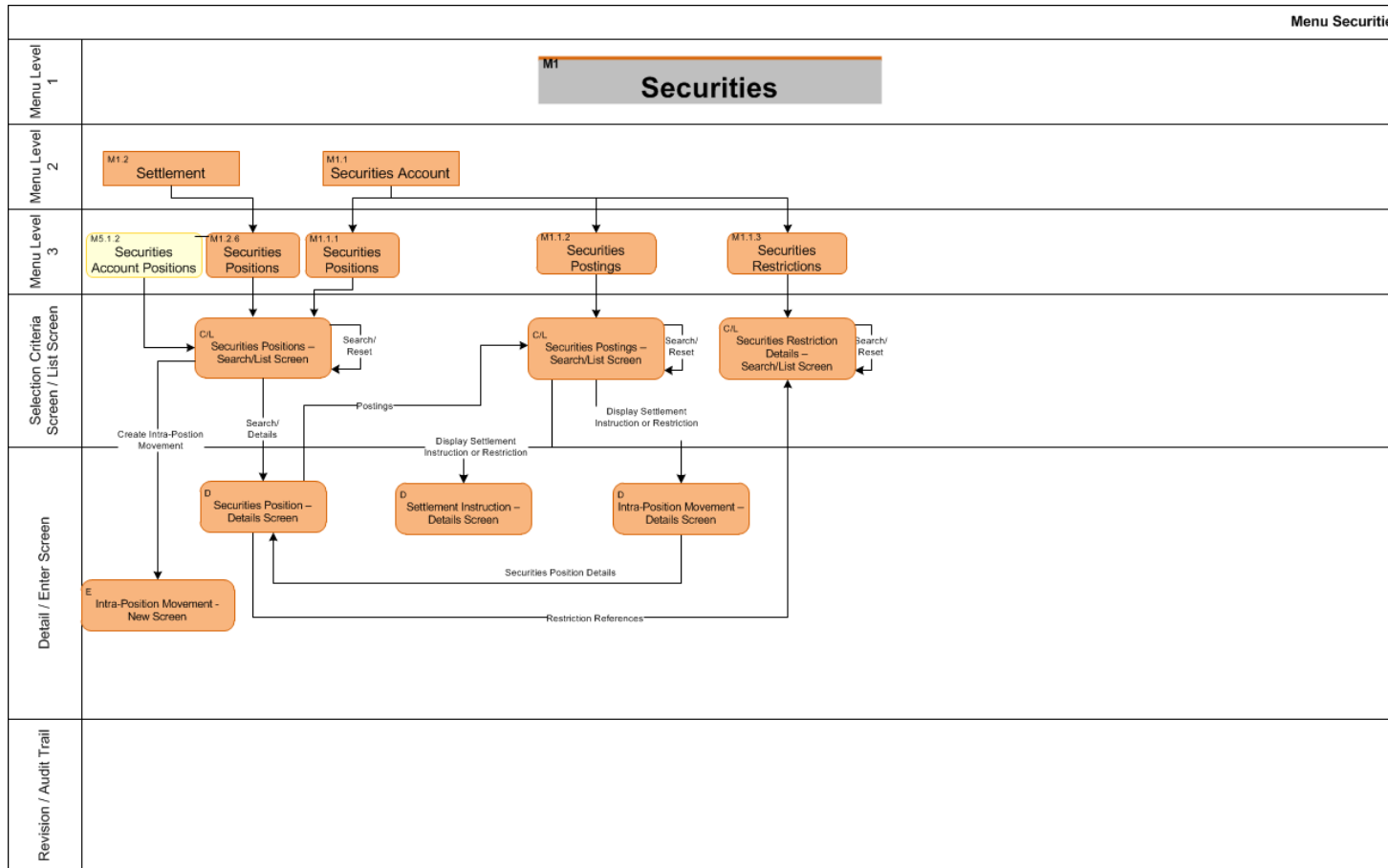

Illustration 141: How to read a sitemap

## 5.2.2 Securities

### 5.2.2.1 Securities Account





## 5.2.2.2 Settlement

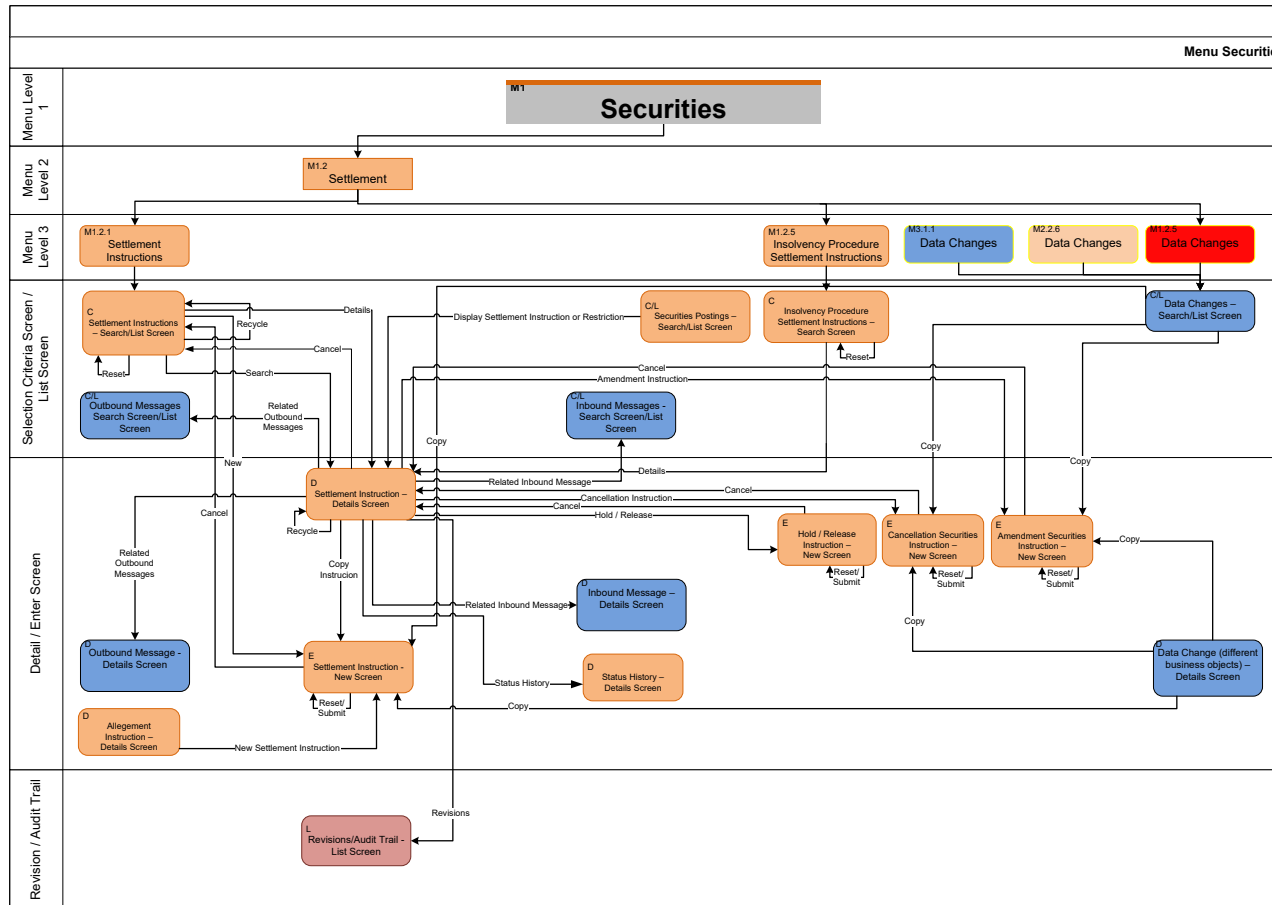

### 5.2.2.3 Settlement II

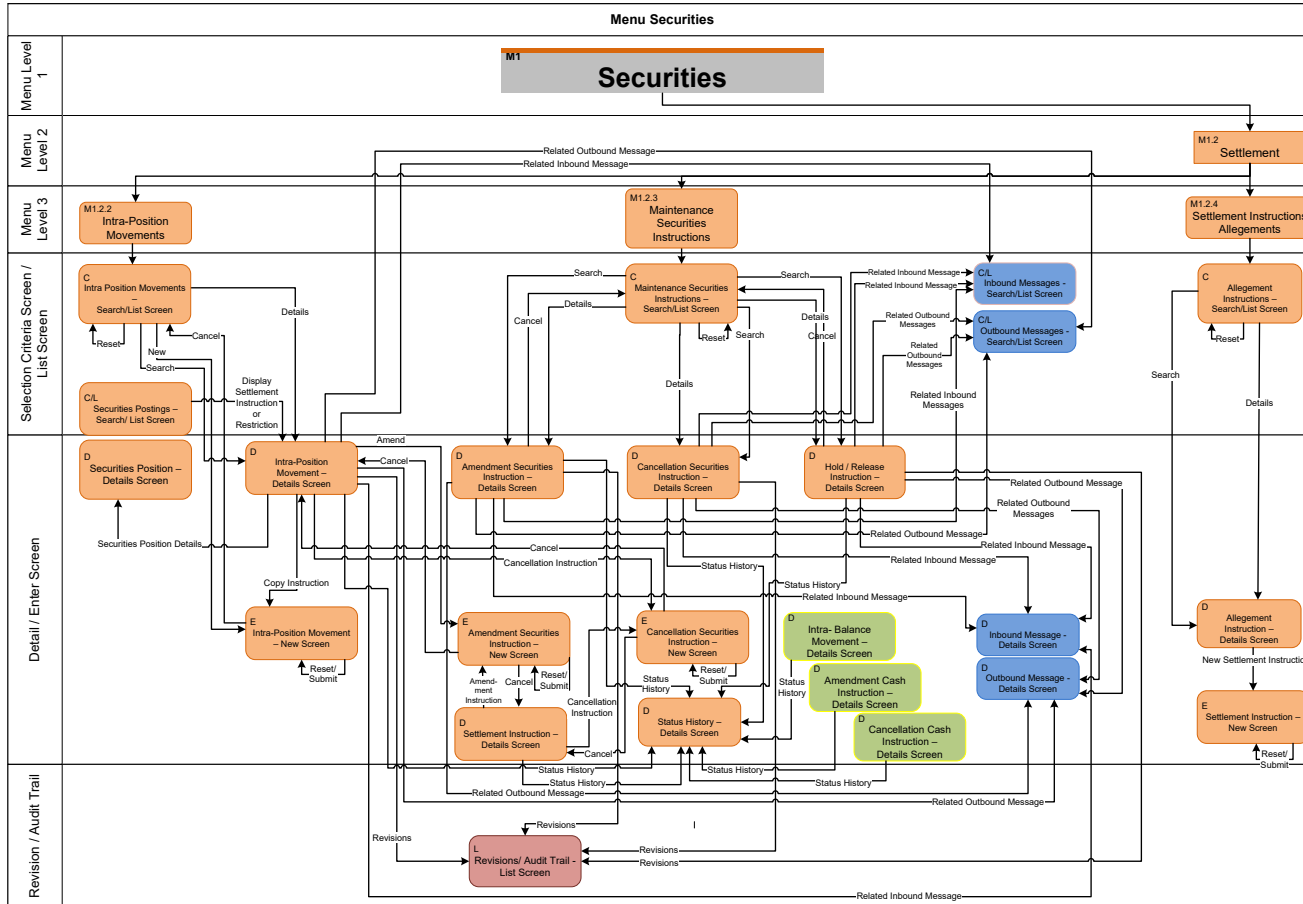

## 5.2.3 Cash

### 5.2.3.1 Cash Account

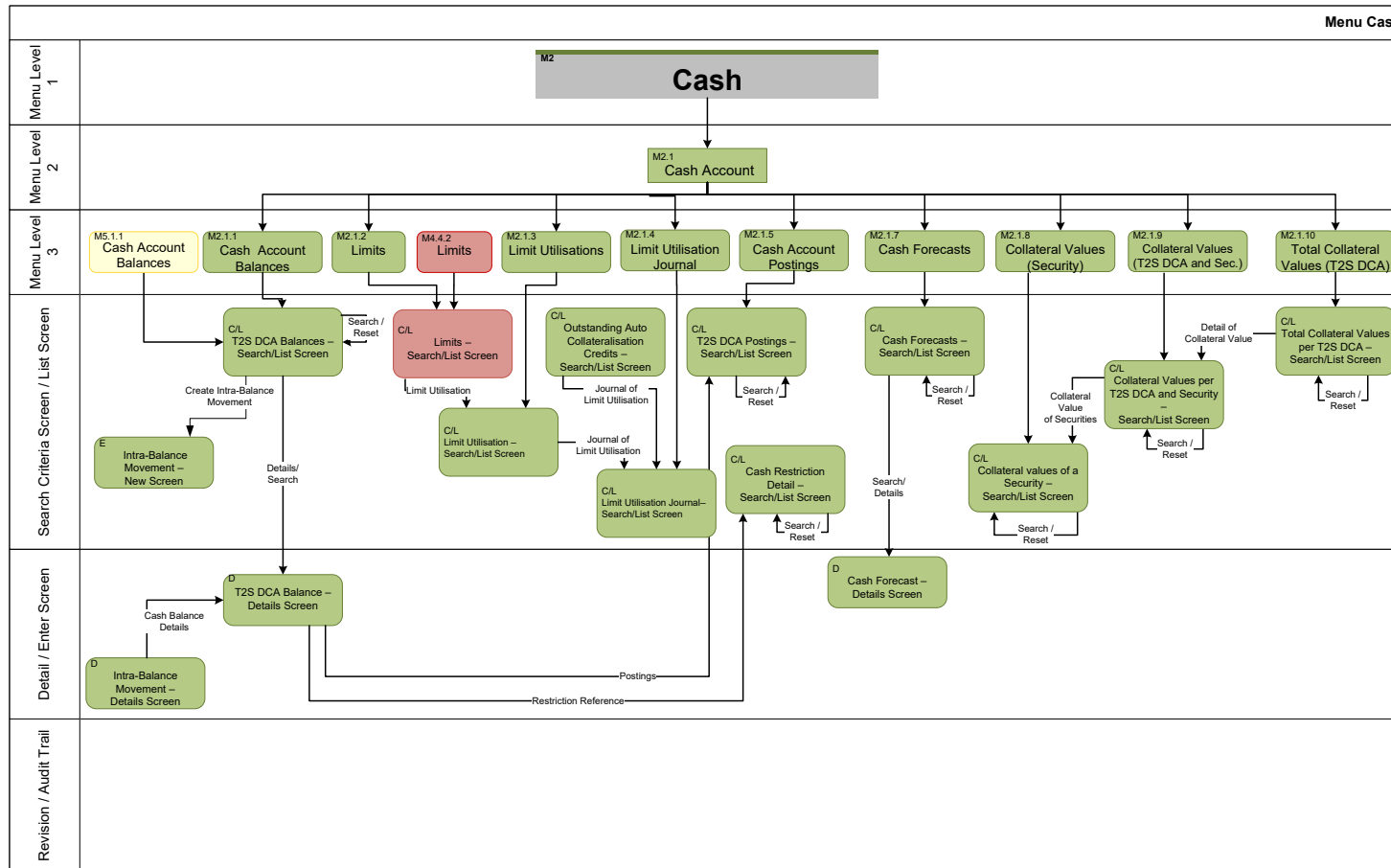

### 5.2.3.2 Liquidity

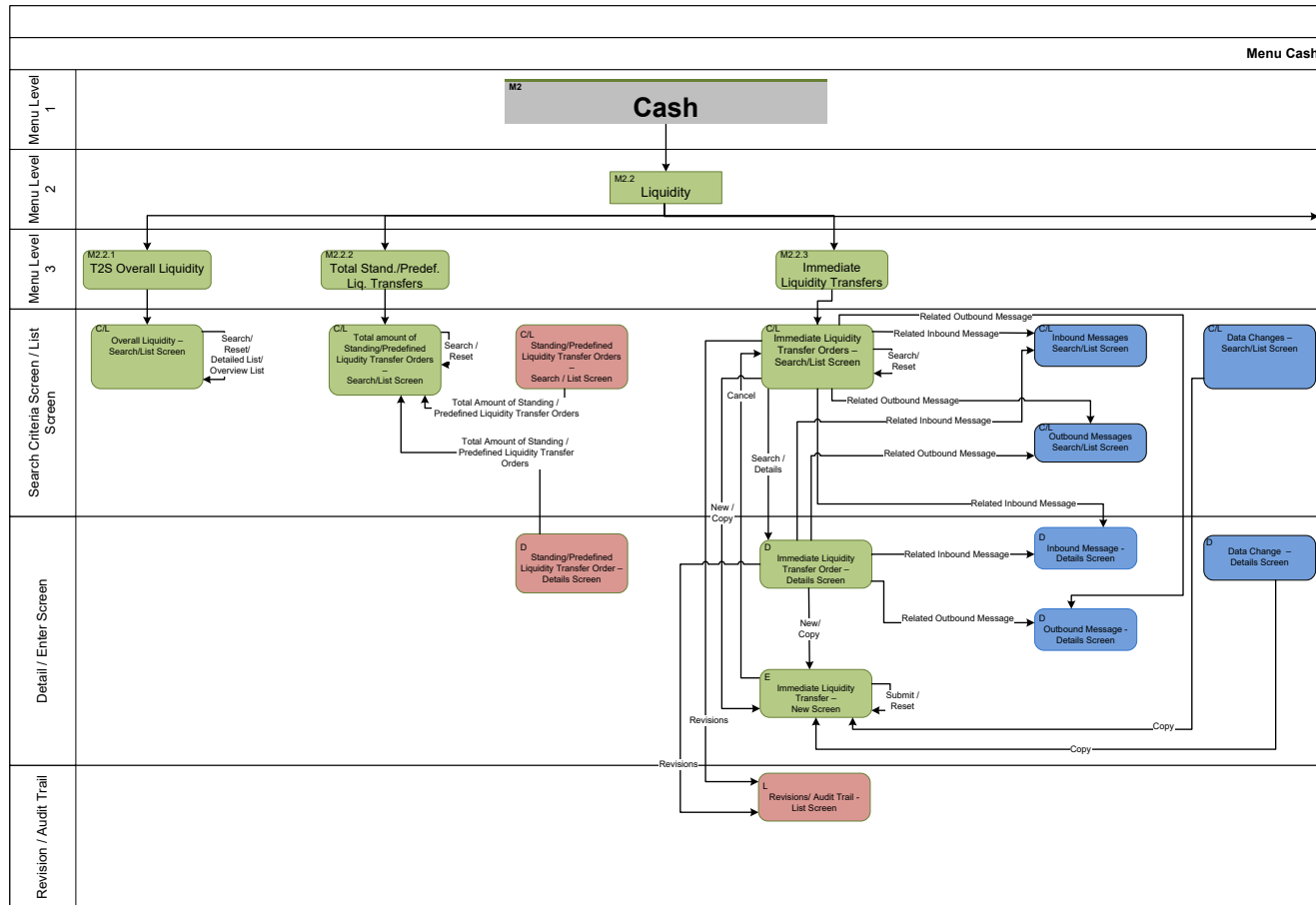

### 5.2.3.3 Liquidity II

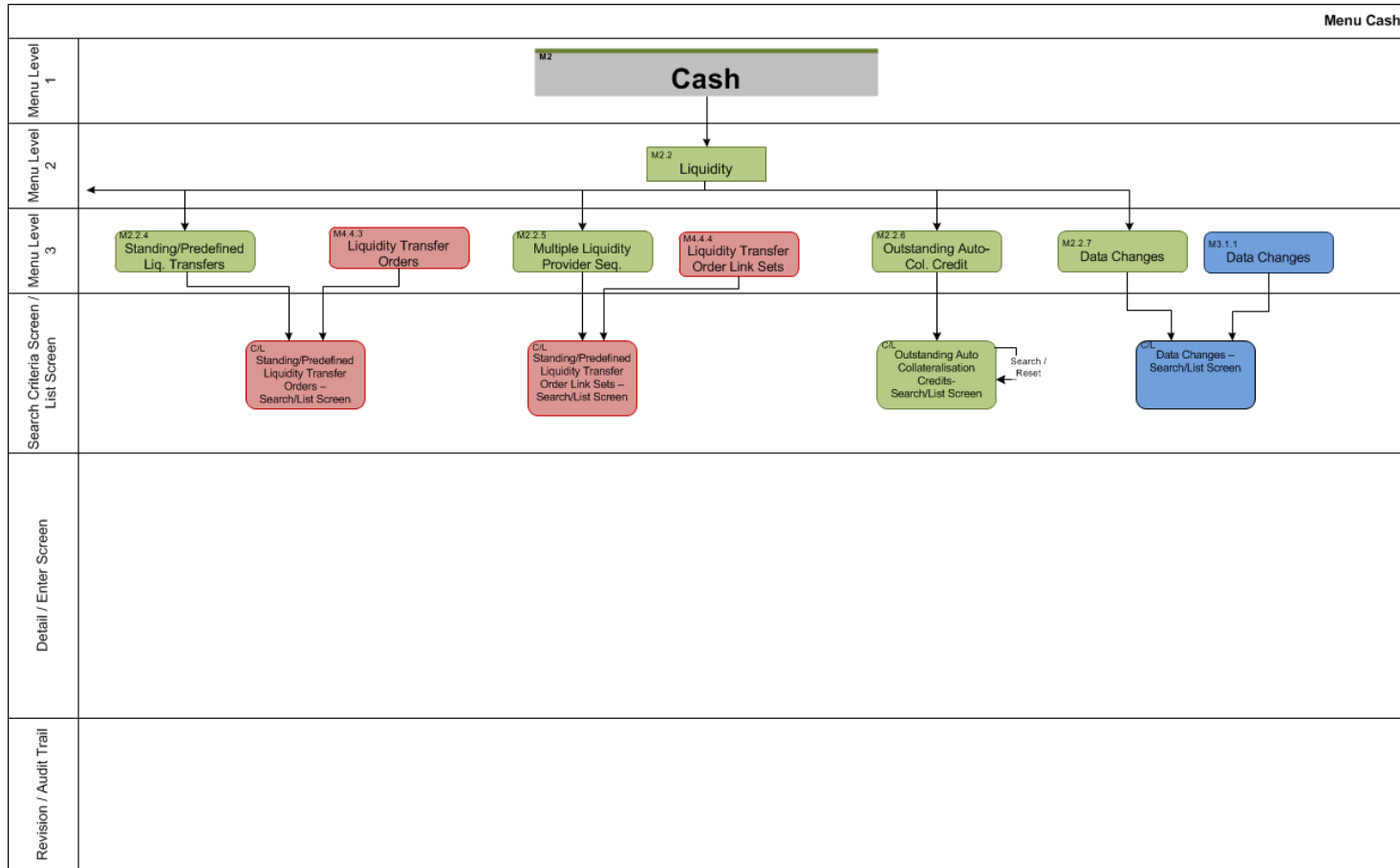

### 5.2.3.4 Settlement

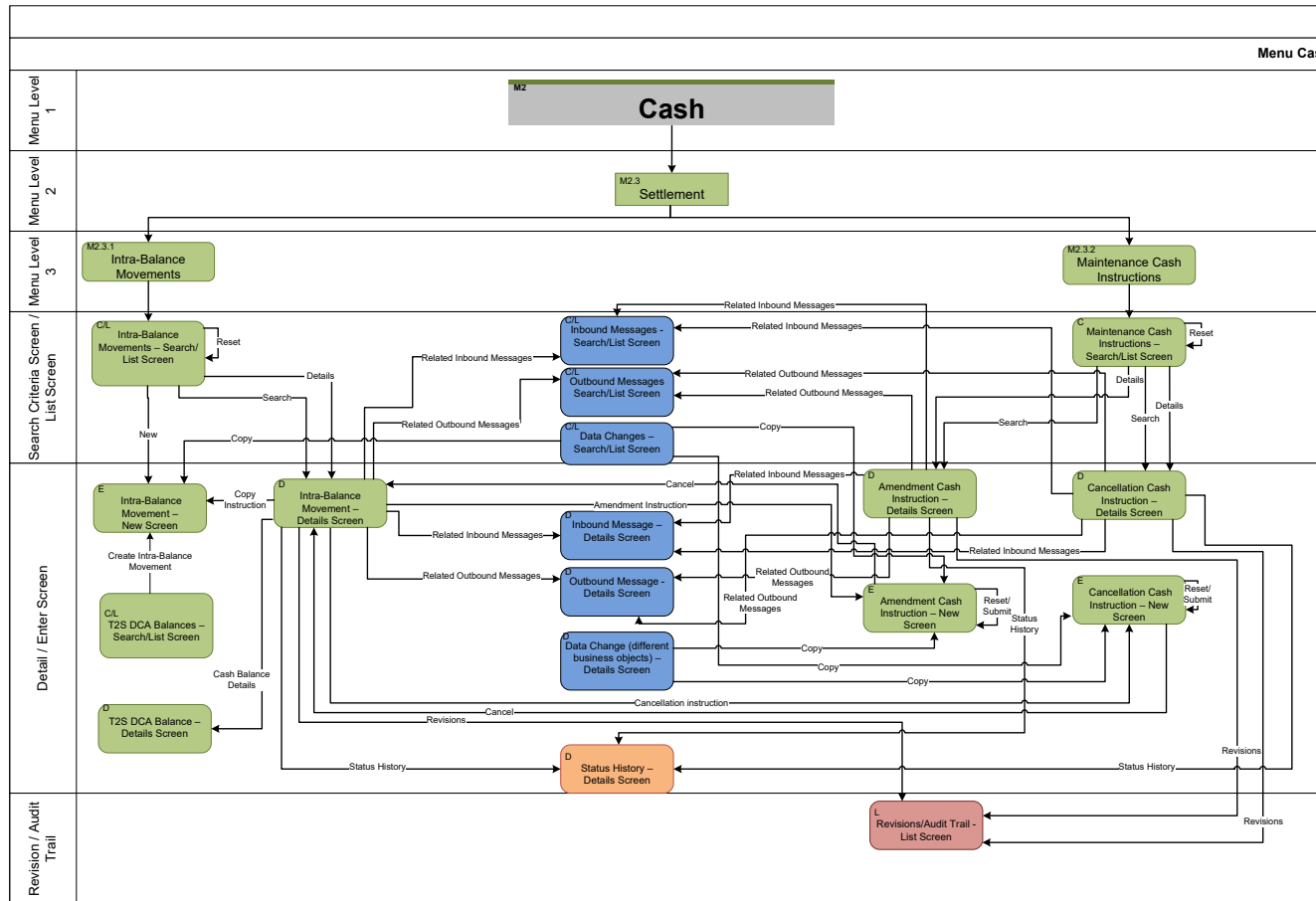

## 5.2.4 Services

### 5.2.4.1 Additional Services

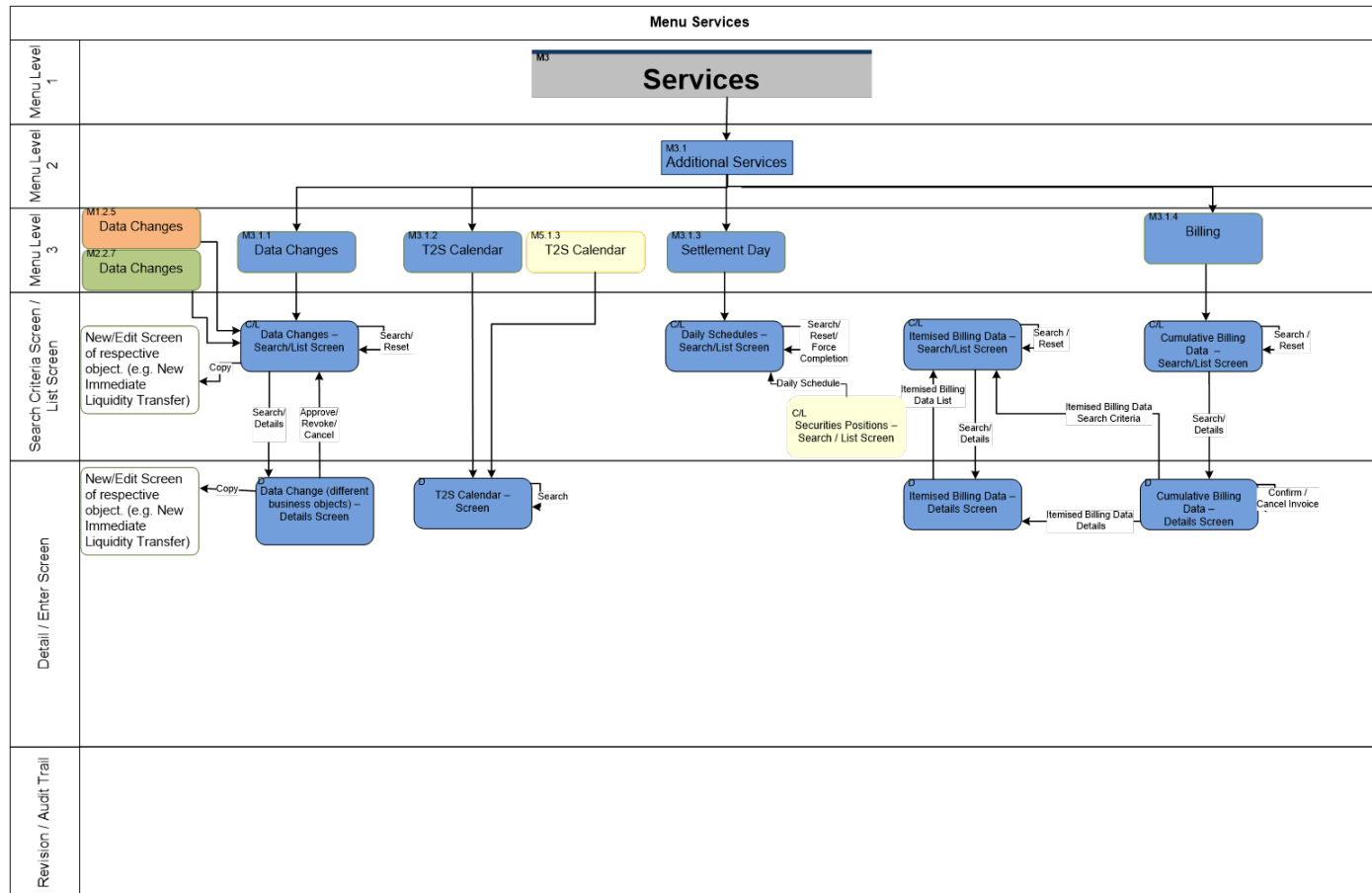

### 5.2.4.2 Additional Services II

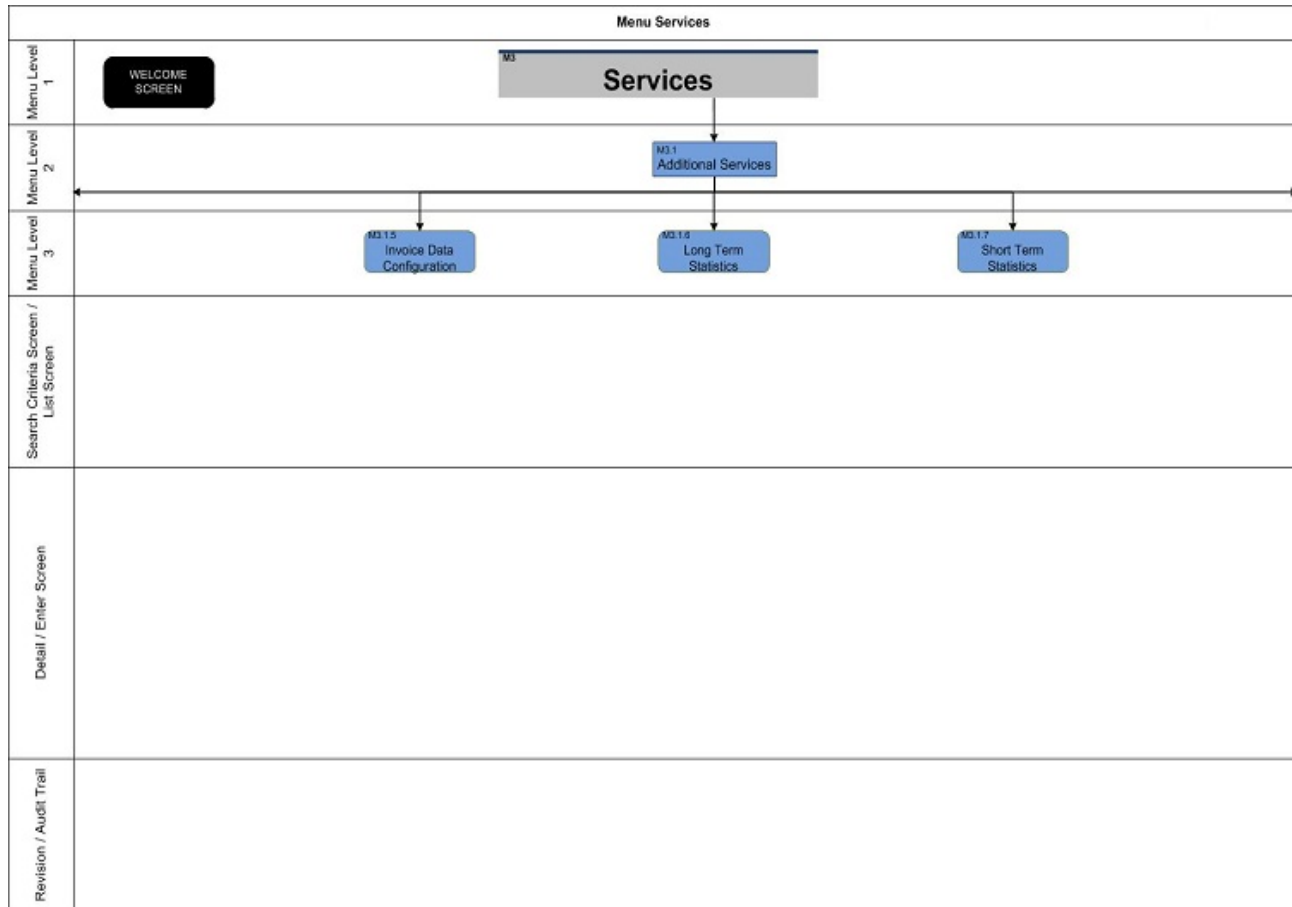



### 5.2.4.3 Additional Services III

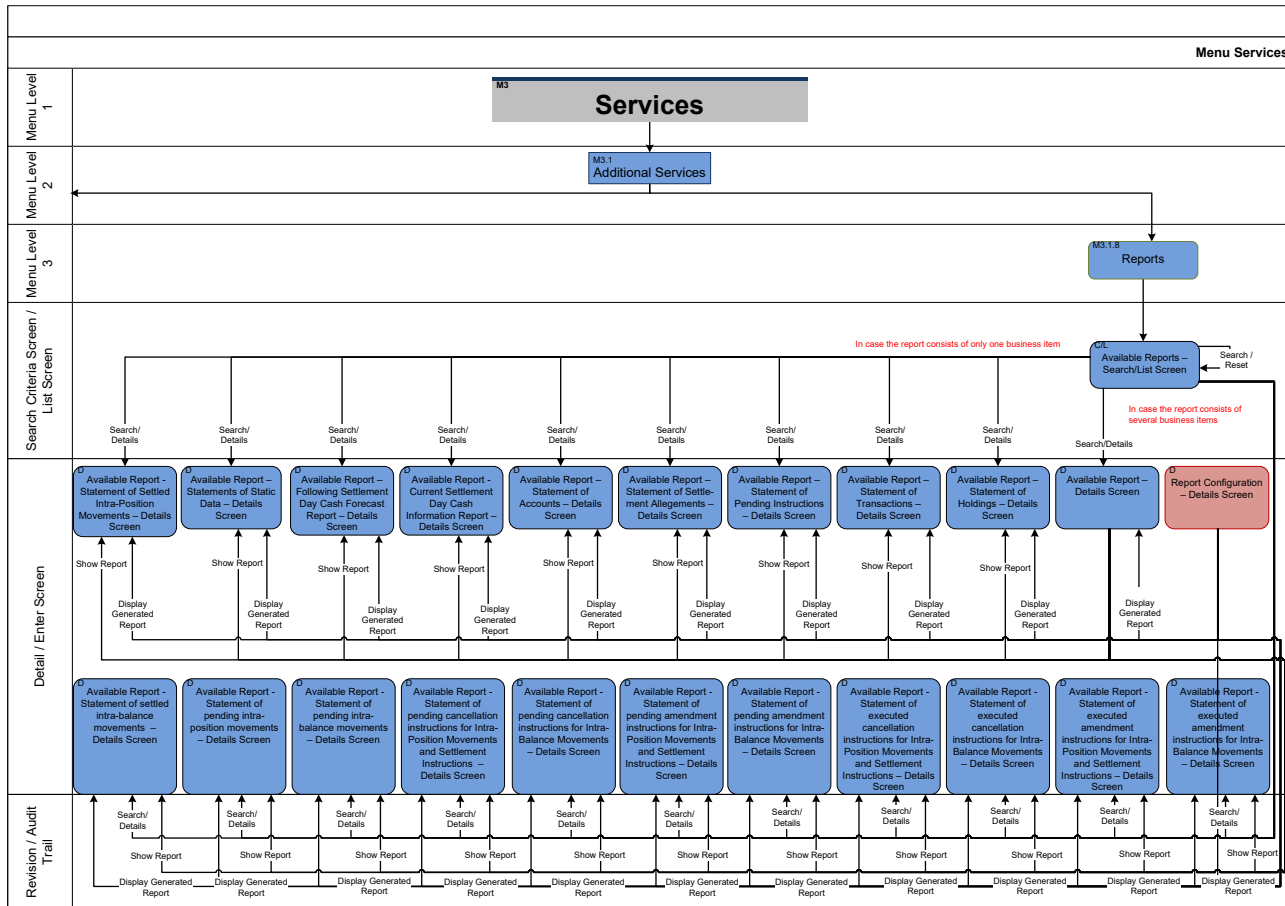

### 5.2.4.4 Additional Services IV



### 5.2.4.5 Additional Services V

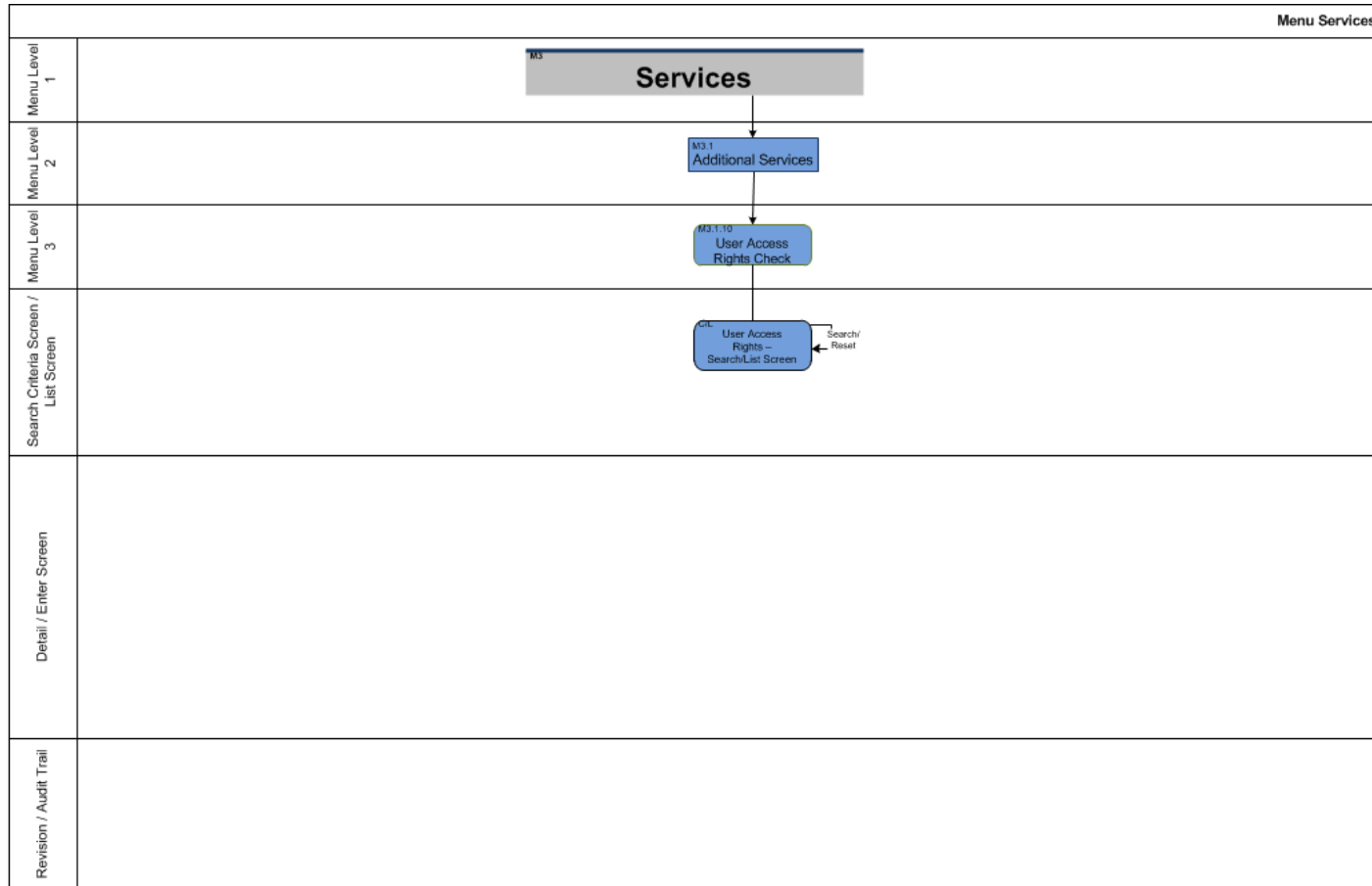

### 5.2.4.6 Additional Services VI

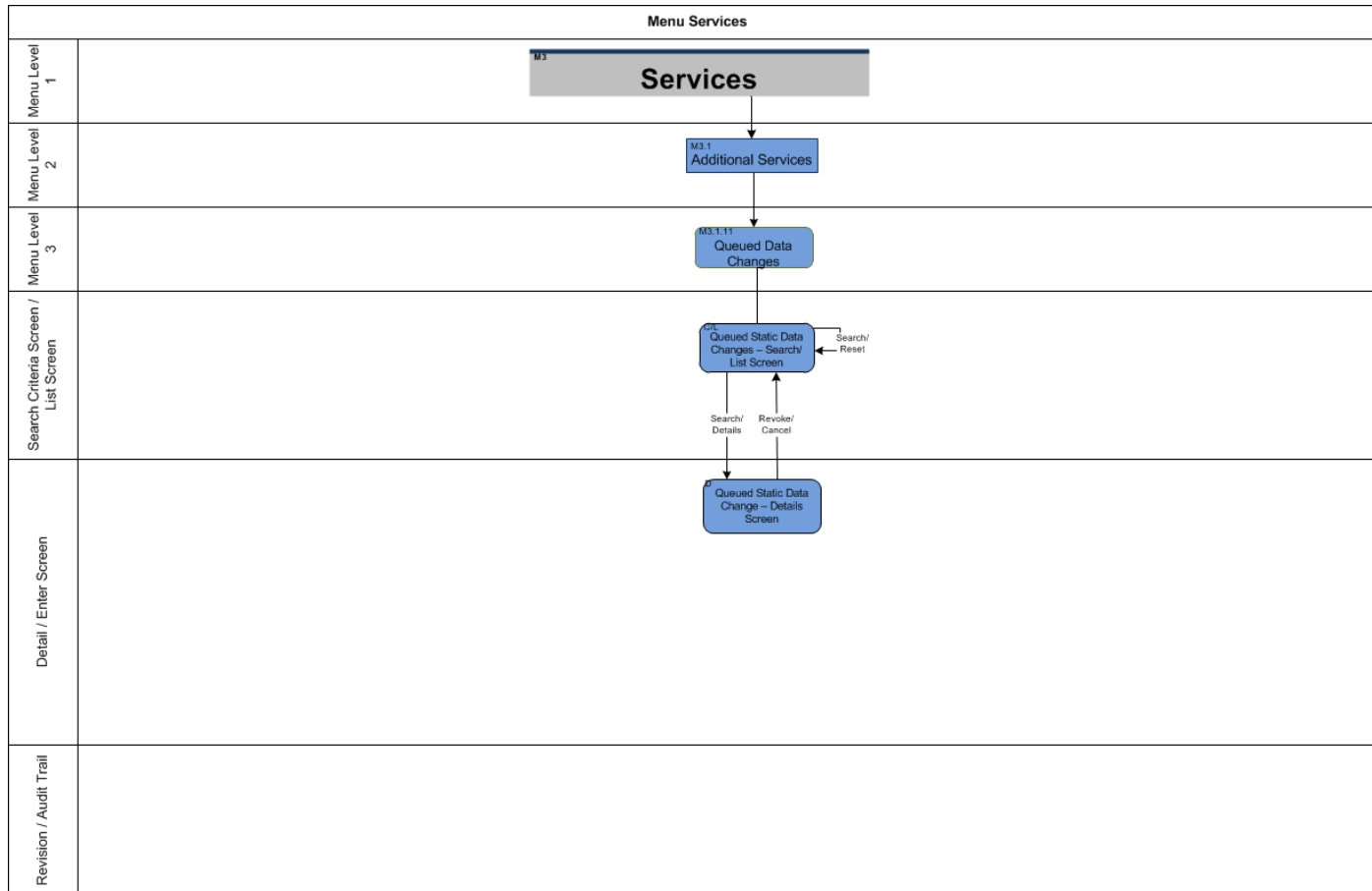

### 5.2.4.7 Communication

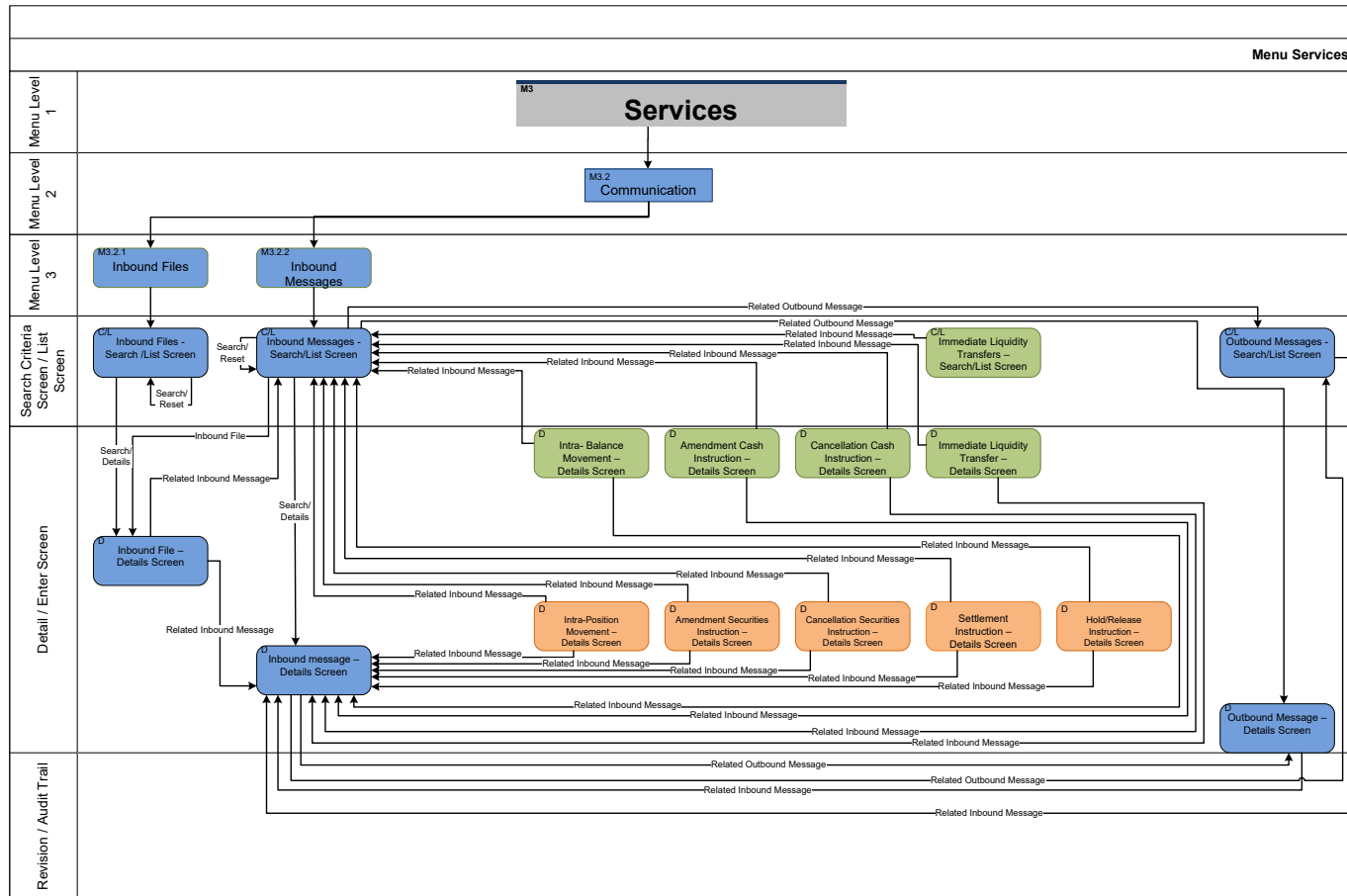

### 5.2.4.8 Communication II

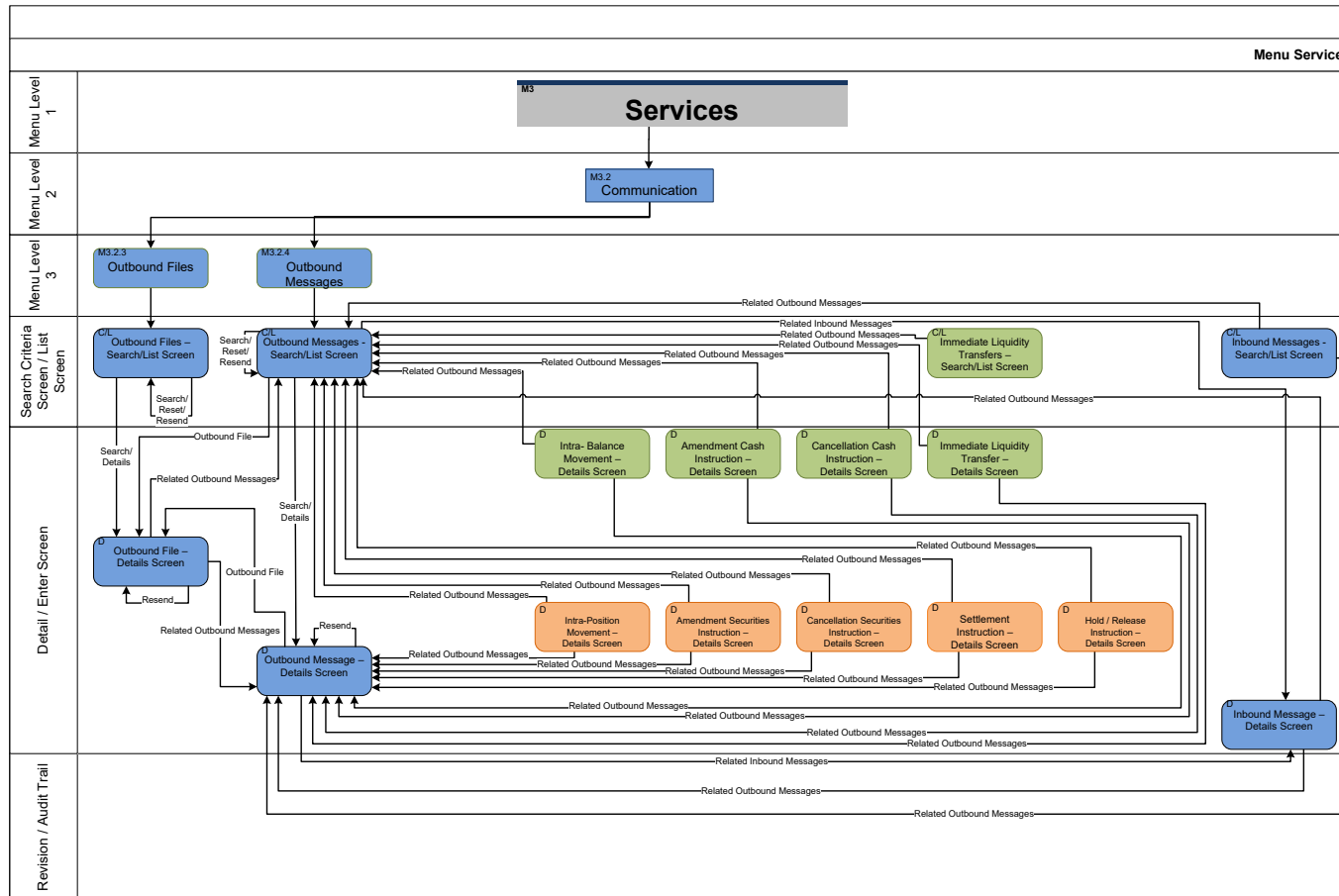

### 5.2.4.9 Communication III

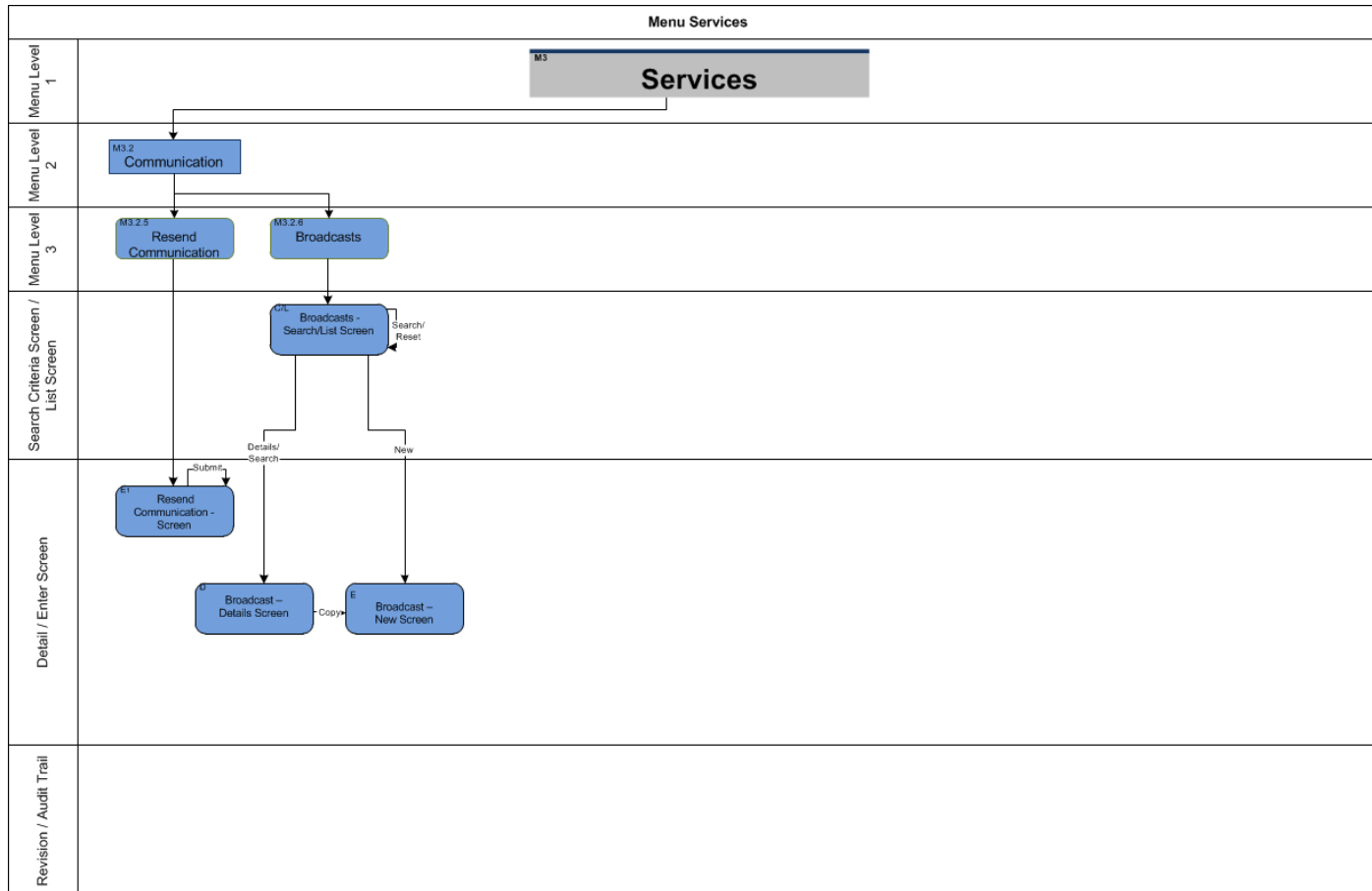

## 5.2.5 Monitoring

### 5.2.5.1 Monitoring

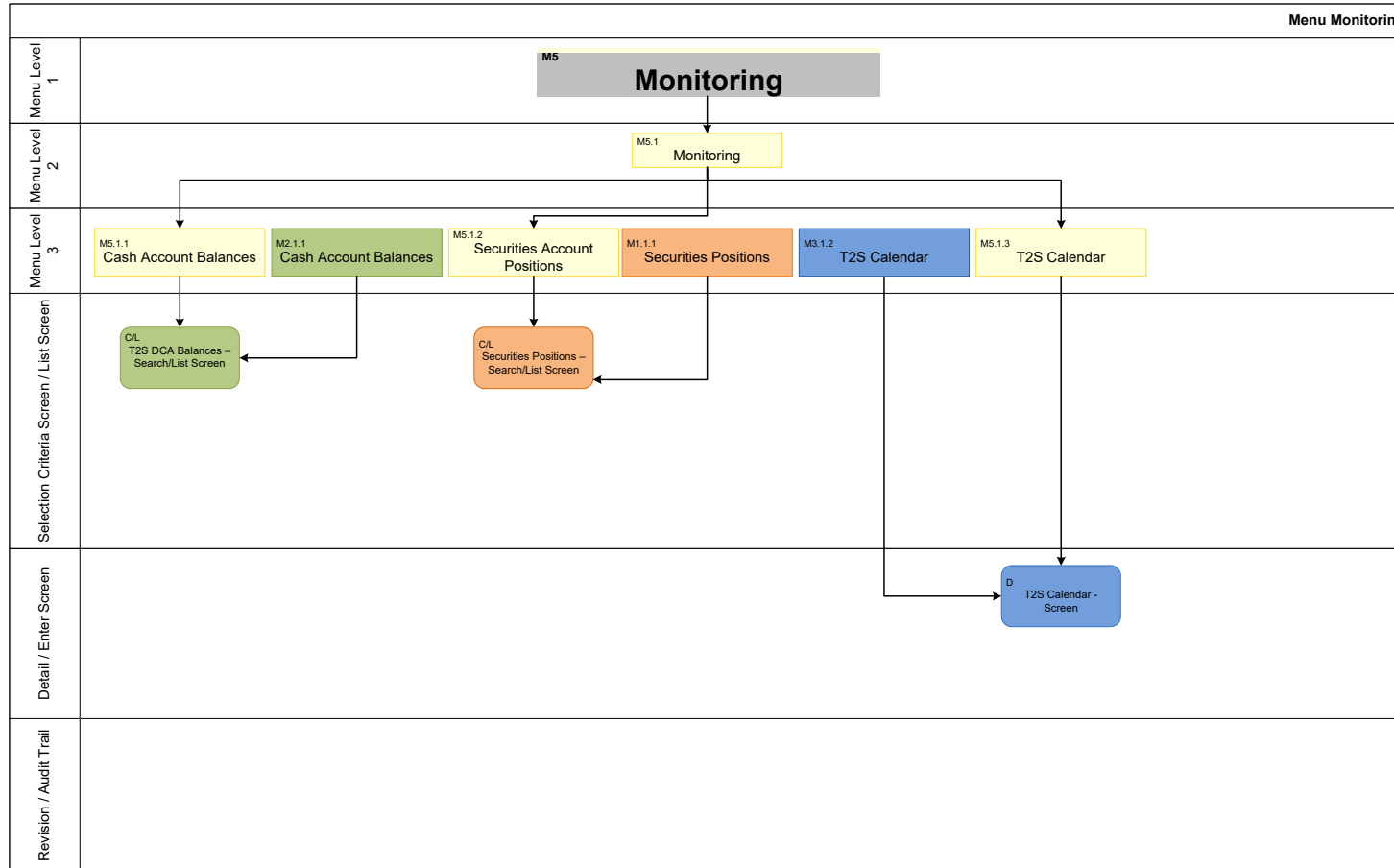



## 5.2.6 Business Day Management

### 5.2.6.1 Business Day Management

#### 5.2.6.1.1 Settlement Day

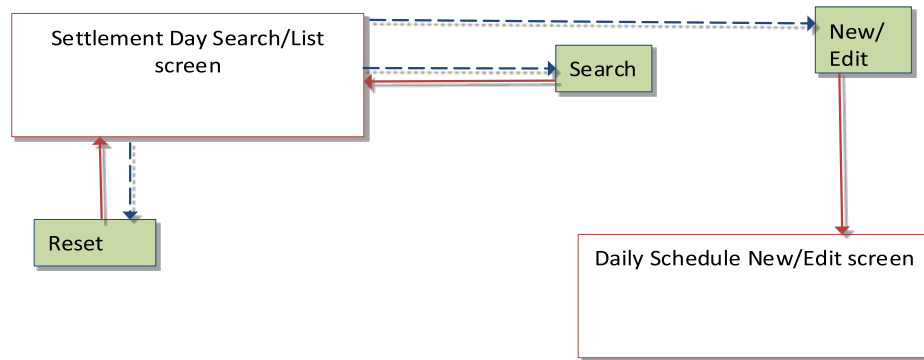

#### 5.2.6.1.2 Calendar

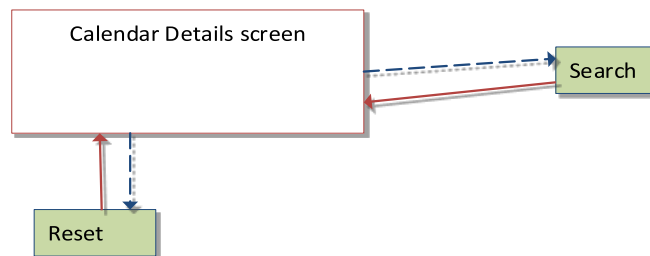

## 5.3 List of Privileges

### 5.3.1 Reader's Guide

#### Reader's Guide

The list of privileges is divided for GUI screens. For GUI screens a list of privileges classes is included. Respectively, the list of privileges is structured in accordance with the alphabetical screen order and provides detailed information on privilege code, privilege type, object type and screen criteria related to each privilege.

### 5.3.2 Privilege Classes for GUI Screens

| Class of Privileges      | Privilege Name    | Privilege Short Name |
|--------------------------|-------------------|----------------------|
| Access Rights Management | Create Privilege  | ARM_CreatePrivilege  |
| Access Rights Management | Update Privilege  | ARM_UpdatePrivilege  |
| Access Rights Management | Delete Privilege  | ARM_DeletePrivilege  |
| Access Rights Management | Grant Privilege   | ARM_GrantPrivilege   |
| Access Rights Management | Revoke Privilege  | ARM_RevokePrivilege  |
| Access Rights Management | Create Role       | ARM_CreateRole       |
| Access Rights Management | Update Role       | ARM_UpdateRole       |
| Access Rights Management | Delete Role       | ARM_DeleteRole       |
| Access Rights Management | Grant/Revoke Role | ARM_GrantRole        |
| Access Rights Management | Create User       | ARM_CreateUser       |
| Access Rights Management | Update User       | ARM_UpdateUser       |
| Access Rights Management | Delete User       | ARM_DeleteUser       |

| Class of Privileges      | Privilege Name                                | Privilege Short Name             |
|--------------------------|---|----------------------------------|
| Management               |   |                                  |
| Access Rights Management | Create Certificate Distinguish Name           | ARM_CreateCertificateDN          |
| Access Rights Management | Delete Certificate Distinguish Name           | ARM_DeleteCertificateDN          |
| Access Rights Management | Create User Certificate Distinguish Name Link | ARM_CreateUserCertificateDNLink  |
| Access Rights Management | Delete User Certificate Distinguish Name Link | ARM_DeleteUserCertificateDNLink  |
| Access Rights Management | Create Secured Group                          | ARM_CreateSecuredGroup           |
| Access Rights Management | Update Secured Group                          | ARM_UpdateSecuredGroup           |
| Access Rights Management | Delete Secured Group                          | ARM_DeleteSecuredGroup           |
| Access Rights Management | Administer Party                              | ARM_AdministerParty              |
| Access Rights Queries    | Access Rights Query                           | ARQ_AccessRightsQuery            |
| Access Rights Queries    | Privilege Query                               | ARQ_PrivilegeQuery               |
| Access Rights Queries    | Role List Query                               | ARQ_RoleListQuery                |
| Access Rights Queries    | T2S System User Query (T2S Actor Query)       | ARQ_T2SSysUserQueryT2SActorQuery |
| Access Rights Queries    | Certificate Query                             | ARQ_CertificateDNQuery           |
| Access Rights Queries    | T2S System User Link Query                    | ARQ_UserCertificateDNLinkQuery   |
| Access Rights Queries    | Secured Group List Query                      | ARQ_SecuredGroupListQuery        |
| Access Rights            | Secured Group Details Query                   | ARQ_SecuredGroupDetailsQuery     |

| Class of Privileges   | Privilege Name   | Privilege Short Name                |
|-----------------------|--|-------------------------------------|
| Queries               |  |                                     |
| Access Rights Queries | Granted System Privileges List Query   | ARQ_GrantedSysPrivilegesListQuery   |
| Access Rights Queries | Granted Object Privileges List Query   | ARQ_GrantObjectPrivilegesListQuery  |
| Access Rights Queries | Granted Roles List Query   | ARQ_Granted-RolesListQuery          |
| Billing               | Edit Invoice Data Configuration (update function)                                  | BIL_NewInvoiceData-Config(update)   |
| Billing               | Invoice Processing Request – Cancellation  | BIL_InvoiceProcessingReq-Cancellat  |
| Billing               | Invoice Processing Request – Confirmation  | BIL_InvoiceProcessingReq-Confirmat  |
| Billing               | Invoice Processing Request – Generation  | BIL_InvoiceProcessingReq-Generation |
| Billing               | New Invoice Data Configuration (create function)                                   | BIL_NewInvoiceData-Config(create)   |
| Billing Configuration | Create Service Item  | BIC_CreateServiceItem               |
| Billing Configuration | Update Service Item  | BIC_UpdateServiceItem               |
| Billing Configuration | Delete Service Item  | BIC_DeleteServiceItem               |
| Billing Queries       | PDF Invoice List Query   | BIQ_PDFInvoiceListQuery             |
| Cash Management       | Amend Process Indicator Settlement Restriction on Cash on a Dedicated Cash Account | CAM_ASRCA                           |
| Cash Management       | Cancel Settlement Restriction on Cash on a Dedicated Cash Account                  | CAM_CSRCA                           |
| Cash Management       | Send New Liquidity Transfer  | CAM_Send New Liquidity Transfer     |
| Cash Management       | Send New Settlement Restriction on Cash on a Dedicated Cash Account                | CAM_SNDRC                           |

| Class of Privileges  | Privilege Name  | Privilege Short Name                |
|----------------------|---|-------------------------------------|
| Cash Management      | Unblock CoSD Cash Blocking related to cancelled CoSD Settlement Instructions on Behalf of the relevant CSD in T2S | CAM_UCBBI                           |
| Dynamic Data Queries | Settlement Instruction Query  | DDQ_SettlInstructQuery              |
| Dynamic Data Queries | Settlement Instruction Query for possible restore actions   | DDQ_SettlInstrQueryRestore          |
| Dynamic Data Queries | Settlement Instruction Current Status Query   | DDQ_SettlInstructCurrentStatusQuery |
| Dynamic Data Queries | Settlement Instruction Status Audit Trail Query   | DDQ_SettlInstructStatusAuditTrailQu |
| Dynamic Data Queries | Settlement Instruction Audit Trail Query  | DDQ_SettlInstructAuditTrailQuery    |
| Dynamic Data Queries | Securities Position Detailed Restriction Details Query  | DDQ_SecurPosDetailedRestrDetailsQue |
| Dynamic Data Queries | Securities Posting Query  | DDQ_SecuritiesPostingQuery          |
| Dynamic Data Queries | Securities Account Position Query   | DDQ_SecuritiesAccountPositionQuery  |
| Dynamic Data Queries | Maintenance for Intra-Position Movements and Settlement Instructions Query  | DDQ_MaintForIntraPosMov+SettlInstrQ |
| Dynamic Data Queries | Amendment Instruction Query for Intra-Position Movements and Settlement Instructions                              | DDQ_AmendInstrQIntraPosMov+SetInstr |
| Dynamic Data Queries | Intra-Position Movements Query  | DDQ_IntraPosMovQuery                |
| Dynamic Data Queries | Intra-Position Movements Query for possible restore actions   | DDQ_IntraPosQueryRestore            |

| Class of Privileges  | Privilege Name   | Privilege Short Name                 |
|----------------------|--|--------------------------------------|
| Dynamic Data Queries | Intra-Balance Movements Query for possible restore actions | DDQ_Intra-BalQueryRestore            |
| Dynamic Data Queries | Allegement Query   | DDQ_AllegementQuery                  |
| Dynamic Data Queries | Inbound Message List Query                                 | DDQ_InboundMess-ListQuery            |
| Dynamic Data Queries | Inbound Message Details Query                              | DDQ_InboundMess-DetailsQuery         |
| Dynamic Data Queries | Outbound Message List Query                                | DDQ_OutboundMess-ListQuery           |
| Dynamic Data Queries | Outbound Message Details Query                             | DDQ_OutboundMess-DetailsQuery        |
| Dynamic Data Queries | Inbound Files List Query                                   | DDQ_Inbound-FilesListQuery           |
| Dynamic Data Queries | Inbound Files Details Query                                | DDQ_InboundFilesDe-tailsQuery        |
| Dynamic Data Queries | Outbound Files List Query                                  | DDQ_Outbound-FilesListQuery          |
| Dynamic Data Queries | Outbound Files Details Query                               | DDQ_OutboundFiles-DetailsQuery       |
| Dynamic Data Queries | Data Changes of a Business Object List Query               | DDQ_DataChan-Busi-nessObjListQuery   |
| Dynamic Data Queries | Data Changes of a Business Object Details Query            | DDQ_DataChan-Busi-nessObjDetailQuery |
| Dynamic Data Queries | Intra-Positon Movement Audit Trail List Query              | DDQ_IntraPos-MovAuditTrail-ListQuery |
| Dynamic Data Queries | Intra-Position Movement Audit Trail Details Query          | DDQ_IntraPos-MovAuditTrailDe-tQuery  |
| Dynamic Data Queries | Hold/Release Instruction Audit Trail List Query            | DDQ_HoldReleIn-strAuditTrailLisQuery |

| Class of Privileges  | Privilege Name   | Privilege Short Name                |
|----------------------|--|-------------------------------------|
| Dynamic Data Queries | Hold/Release Instruction Audit Trail Details Query   | DDQ_HoldReleInstrAuditTrailDetQuery |
| Dynamic Data Queries | Amendment Instruction for Intra-Position Movement or Settlement Instruction Audit Trail List Query       | DDQ_AmdInsIntrPosMovSetInsAudTrLisQ |
| Dynamic Data Queries | Amendment Instruction for Intra-Position Movement or Settlement Instruction Audit Trail Details Query    | DDQ_AmdInsIntrPosMovSetInsAudTrDetQ |
| Dynamic Data Queries | Cancellation Instruction for Intra-Balance Movement Audit Trail Details Query                            | DDQ_CanlInstrIntraBalanMovAudTrDetQ |
| Dynamic Data Queries | Cancellation Instruction for Intra-Balance Movement Audit Trail List Query                               | DDQ_CanlInstrIntraBalanMovAudTrLisQ |
| Dynamic Data Queries | Cancellation Instruction for Intra-Position Movement or Settlement Instruction Audit Trail List Query    | DDQ_CanlInstrIntraPosMovAudTrLisQ   |
| Dynamic Data Queries | Cancellation Instruction for Intra-Position Movement or Settlement Instruction Audit Trail Details Query | DDQ_CanlInstrIntraPosMovAudTrDetQ   |
| Dynamic Data Queries | Cancellation Instruction Query for Intra-position Movements and Settlement Instructions                  | DDQ_CanlInstrForSI+IntraPosMovQuery |
| Dynamic Data Queries | Broadcast Query  | DDQ_BroadcastQuery                  |
| Dynamic Data Queries | Amendment Instruction for Intra-Balance Movement Audit Trail Details Query                               | DDQ_AmdInstrForIntraBalMovAudTrDetQ |
| Dynamic Data Queries | Amendment Instruction for Intra-Balance Movement Audit Trail List Query                                  | DDQ_AmdInstrForIntraBalMovAudTrLisQ |

| Class of Privileges  | Privilege Name   | Privilege Short Name                              |
|----------------------|--|---|
| Dynamic Data Queries | Amendment Instruction Query for Intra-Balance Movements      | DDQ_AmendInstrQueryForIntraBal-anMo               |
| Dynamic Data Queries | Cancellation Instructions for Intra-Balance Movements Query  | DDQ_CancInstructIntraBalanMovQuery                |
| Dynamic Data Queries | Cash Forecast Query  | DDQ_CashForecastQuery                             |
| Dynamic Data Queries | Collateral Value of a Security Query                         | DDQ_CollatValue-of-SecurityQuery                  |
| Dynamic Data Queries | Collateral Value per T2S Dedicated Cash Account Query        | DDQ_CollatValuePer-T2SDCAQuery                    |
| Dynamic Data Queries | Immediate Liquidity Transfer Order Audit Trail Details Query | DDQ_ImmedLiquidityTransOrderAuditTrailDetailQuery |
| Dynamic Data Queries | Immediate Liquidity Transfer Order Audit Trail List Query    | DDQ_ImmedLiquidityTransOrderAuditTrailListQuery   |
| Dynamic Data Queries | Immediate Liquidity Transfer Order Detail Query              | DDQ_ImmedLiquidityTransOrderDetailQuery           |
| Dynamic Data Queries | Immediate Liquidity Transfer Order List Query                | DDQ_ImmedLiquidityTransOrderListQuery             |
| Dynamic Data Queries | Intra-Balance Movement Audit Trail Detail Query              | DDQ_IntraBalanMovAuditTrailDetailQuery            |
| Dynamic Data Queries | Intra-Balance Movement Audit Trail List Query                | DDQ_IntraBalanMovAuditTrailListQuery              |
| Dynamic Data Queries | Intra-Balance Movements Query                                | DDQ_IntraBalanMovQuery                            |
| Dynamic Data Queries | Limit Utilisation Journal Query                              | DDQ_LimitUtilisation-JournalQuery                 |
| Dynamic Data Queries | Limit Utilisation Query                                      | DDQ_LimitUtilisation-Query                        |



| Class of Privileges              | Privilege Name   | Privilege Short Name                    |
|----------------------------------|--|---|
| Dynamic Data Queries             | Maintenance Instruction for Intra-Balance Movements Query          | DDQ_MaintInstrForIntraBalanMovQuer      |
| Dynamic Data Queries             | Outstanding Auto-Collateralisation Credit Query                    | DDQ_OutstandAutoCollCreditQuery         |
| Dynamic Data Queries             | T2S Dedicated Cash Account Balance Detailed Restrictions Query     | DDQ_T2SDCABalAnDetailedRestrictionQuery |
| Dynamic Data Queries             | T2S Dedicated Cash Account Balance Query                           | DDQ_T2SDedicatedCashAccBalanceQuery     |
| Dynamic Data Queries             | T2S Dedicated Cash Account Posting Query                           | DDQ_T2SDedicatedCashAccPostingQuery     |
| Dynamic Data Queries             | T2S Overall Liquidity Query  | DDQ_T2SOverallLiquidityQuery            |
| Dynamic Data Queries             | Total Collateral Value per T2S Dedicated Cash Account Query        | DDQ_TotalCollatValuePerT2SDCAQuery      |
| Dynamic Data Queries             | Settlement Instruction Matched and Accepted Status Query Privilege | DDQ_SettlInstrMchAcceptStsQuery         |
| General Configuration Parameters | Create Country   | GCP_CreateCountry                       |
| General Configuration Parameters | Update Country   | GCP_UpdateCountry                       |
| General Configuration Parameters | Delete Country   | GCP_DeleteCountry                       |
| General Configuration Parameters | Create Currency  | GCP_CreateCurrency                      |
| General Configuration Parameters | Update Currency  | GCP_UpdateCurrency                      |
| General Configuration Parameters | Delete Currency  | GCP_DeleteCurrency                      |
| General Configuration Parameters | Create Partial Settlement Threshold                                | GCP_CreatePartialSettlThreshold         |
| General Configuration Parameters | Update Partial Settlement Threshold                                | GCP_UpdatePartialSettlThreshold         |

| Class of Privileges              | Privilege Name                      | Privilege Short Name               |
|----------------------------------|-------------------------------------|------------------------------------|
| General Configuration Parameters | Delete Partial Settlement Threshold | GCP_DeletePartial-SettlThreshold   |
| General Configuration Parameters | Create System Entity                | GCP_CreateSystemEntity             |
| General Configuration Parameters | Update System Entity                | GCP_UpdateSystemEntity             |
| General Configuration Parameters | Create Tolerance Amount             | GCP_CreateToleranceAmount          |
| General Configuration Parameters | Update Tolerance Amount             | GCP_UpdateToleranceAmount          |
| General Configuration Parameters | Delete Tolerance Amount             | GCP_DeleteToleranceAmount          |
| Market-Specific Configuration    | Create Attribute Domain             | MSC_CreateAttribute-Domain         |
| Market-Specific Configuration    | Update Attribute Domain             | MSC_UpdateAttribute-Domain         |
| Market-Specific Configuration    | Delete Attribute Domain             | MSC_DeleteAttribute-Domain         |
| Market-Specific Configuration    | Create Attribute Reference          | MSC_CreateAttributeReference       |
| Market-Specific Configuration    | Update Attribute Reference          | MSC_UpdateAttributeReference       |
| Market-Specific Configuration    | Delete Attribute Reference          | MSC_DeleteAttributeReference       |
| Market-Specific Configuration    | Create Market-Specific Attribute    | MSC_CreateMarket-SpecificAttribute |
| Market-Specific Configuration    | Update Market-Specific Attribute    | MSC_UpdateMarket-SpecificAttribute |
| Market-Specific Configuration    | Delete Market-Specific Attribute    | MSC_DeleteMarket-SpecificAttribute |
| Market-Specific Configuration    | Create Restriction Type             | MSC_CreateRestrictionType          |
| Market-Specific Configuration    | Update Restriction Type             | MSC_UpdateRestrictionType          |

| Class of Privileges           | Privilege Name                                | Privilege Short Name              |
|-------------------------------|---|-----------------------------------|
| Market-Specific Configuration | Delete Restriction Type                       | MSC_DeleteRestrictionType         |
| Market-Specific Configuration | Create Restriction Type Rule                  | MSC_CreateRestrictionTypeRule     |
| Market-Specific Configuration | Update Restriction Type Rule                  | MSC_UpdateRestrictionTypeRule     |
| Market-Specific Configuration | Delete Restriction Type Rule                  | MSC_DeleteRestrictionTypeRule     |
| Market-Specific Configuration | Create Conditional Security Delivery Rule Set | MSC_CreateConditSecurDelivRuleSet |
| Market-Specific Configuration | Update Conditional Security Delivery Rule Set | MSC_UpdateConditSecurDelivRuleSet |
| Market-Specific Configuration | Delete Conditional Security Delivery Rule Set | MSC_DeleteConditSecurDelivRuleSet |
| Market-Specific Configuration | Create Conditional Security Delivery Rule     | MSC_CreateConditSecurDelivRule    |
| Market-Specific Configuration | Update Conditional Security Delivery Rule     | MSC_UpdateConditSecurDelivRule    |
| Market-Specific Configuration | Delete Conditional Security Delivery Rule     | MSC_DeleteConditSecurDelivRule    |
| Message Management            | Resend Communication                          | MMA_Resend Communication          |
| Message Management            | Third party receipt                           | MMA_Third party receipt           |
| Message Subscription          | Create Message Subscription Rule Set          | MSU_CreateMessSubsRuleSet         |
| Message Subscription          | Update Message Subscription Rule Set          | MSU_UpdateMessSubscriptionRuleSet |
| Message Subscription          | Delete Message Subscription Rule Set          | MSU_DeleteMessSubscriptionRuleSet |
| Message Subscription          | Create Message Subscription Rule              | MSU_CreateMessageSubscriptionRule |

| Class of Privileges          | Privilege Name                                       | Privilege Short Name                |
|------------------------------|--|-------------------------------------|
| Message Subscription         | Update Message Subscription Rule                     | MSU_UpdateMessageSubscriptionRule   |
| Message Subscription         | Delete Message Subscription Rule                     | MSU_DeleteMessageSubscriptionRule   |
| Message Subscription Queries | Message Subscription Rule Set List Query             | MSQ_MessSubscrRuleSetListQuery      |
| Message Subscription Queries | Message Subscription Rule List Query                 | MSQ_MessSubscrRuleListQuery         |
| Message Management           | RTGS answer  | MMA_RTGS answer                     |
| Message Management           | New Broadcast  | MMA_New Broadcast                   |
| Message Subscription Queries | Message Subscription Rule Set Details Query          | MSQ_MessSubscrRuleSetDetailQuery    |
| MSA Data Queries             | Attribute Domain List Query                          | MSA_AttributeDomainListQuery        |
| MSA Data Queries             | Attribute Domain Details Query                       | MSA_AttributeDomainDetailsQuery     |
| MSA Data Queries             | Market-specific Attribute List Query                 | MSA_Market-SpecAttributeQuery       |
| MSA Data Queries             | Market-specific Attribute Detail Query               | MSA_Market-SpecAttributeDetailQuery |
| MSA Data Queries             | Market-specific Restriction List Query               | MSA_Market-SpecRestrictListQuery    |
| MSA Data Queries             | Conditional Security Delivery Rule Set Query         | MSA_ConditSecDeliveryRuleSetQuery   |
| MSA Data Queries             | Attribute Reference List Query                       | MSA_DisplayAttribDomainRefListQuery |
| MSA Data Queries             | Market-specific Restriction Type Rule Detail Query   | MSA_Market-SpecRestrictDetailQuery  |
| MSA Data Queries             | Market-specific Restriction Type Rule Set List Query | MSA_MarkSpecRestrTypeRuleSetListQue |

| Class of Privileges           | Privilege Name  | Privilege Short Name                |
|-------------------------------|---|-------------------------------------|
| MSA Data Queries              | Market-specific Restriction Type Rule Parameter Details Query | MSA_MarkSpecRestr-TypeRuleParamDetQ |
| MSA Data Queries              | Conditional Security Delivery Rule List Query                 | MSA_ConditSecDeliveryRuleQuery      |
| MSA Data Queries              | Attribute Reference Details Query                             | MSA_DisplayAttribDomainRefDetQuery  |
| Network Configuration         | Create Network Service  | NCO_CreateNetwork-Service           |
| Network Configuration         | Update Network Service  | NCO_UpdateNetwork-Service           |
| Network Configuration         | Delete Network Service  | NCO_DeleteNetwork-Service           |
| Network Configuration         | Create Routing  | NCO_CreateRouting                   |
| Network Configuration         | Update Routing  | NCO_UpdateRouting                   |
| Network Configuration         | Delete Routing  | NCO_DeleteRouting                   |
| Network Configuration         | Create Technical Address Network Service Link                 | NCO_CreateTechnAd-dressNetServLink  |
| Network Configuration         | Update Technical Address Network Service Link                 | NCO_UpdateTech-nAddressNetServLink  |
| Network Configuration         | Delete Technical Address Network Service Link                 | NCO_DeleteTechnAd-dressNetServLink  |
| Network Configuration         | Create T2S BIC Directory                                      | NCO_CreateT2SBIC-Directory          |
| Network Configuration         | Update T2S BIC Directory                                      | NCO_UpdateT2SBIC-Directory          |
| Network Configuration         | Delete T2S BIC Directory                                      | NCO_DeleteT2SBIC-Directory          |
| Network Configuration Queries | T2S BIC Query   | NCQ_T2SBICQuery                     |

| Class of Privileges           | Privilege Name                                       | Privilege Short Name               |
|-------------------------------|--|------------------------------------|
| Network Configuration Queries | Network Service List query                           | NCQ_NetworkServiceListquery        |
| Network Configuration Queries | Routing List Query                                   | NCQ_RoutingListQuery               |
| Network Configuration Queries | Technical Address Network Service Link Details Query | NCQ_DisplayTechAddressNetSerLink   |
| Party Data Management         | Create Party   | PDM_CreateParty                    |
| Party Data Management         | Update Party   | PDM_UpdateParty                    |
| Party Data Management         | Delete Party   | PDM_DeleteParty                    |
| Party Data Queries            | Party Audit Trail Query                              | PDQ_PartyAudTrailQuery             |
| Party Data Queries            | Party Reference Data Query                           | PDQ_PartyReferenceDataQuery        |
| Party Data Queries            | Party List Query                                     | PDQ_PartyListQuery                 |
| Party Data Queries            | Restricted Party Query                               | PDQ_RestrictedPartyQuery           |
| Report Configuration          | Create Report Configuration                          | RCO_CreateReportConfiguration      |
| Report Configuration          | Update Report Configuration                          | RCO_UpdateReportConfiguration      |
| Report Configuration          | Delete Report Configuration                          | RCO_DeleteReportConfiguration      |
| Report Configuration Queries  | Report Configuration Details Query                   | RCO_ReportConfigurationDetailQuery |
| Report Configuration Queries  | Report Configuration List Query                      | RCO_ReportConfigurationListQuery   |
| Report Queries                | Report List Query                                    | RCO_ReportListQuery                |

| Class of Privileges | Privilege Name                              | Privilege Short Name                     |
|---------------------|---|--|
| Report Queries      | Report Details Query                        | RCO_ReportDe-<br>tailsQuery              |
| SAC Data Queries    | Securities Account List Query               | SAQ_SecuritiesAc-<br>countListQuery      |
| SAC Data Queries    | Securities Account Reference<br>Data Query  | SAQ_SecuritiesAc-<br>cReferenceDataQuery |
| SAC Data Queries    | Securities Account Audit Trail<br>Query     | SAQ_SecuritiesAc-<br>cAudTrailQuery      |
| SAC Data Queries    | CSD Account Link Query                      | SAQ_CSDAccount-<br>LinkQuery             |
| SAC Data Queries    | CMB Securities Account Link<br>List Query   | SAQ_DisplayCMB-<br>SecAccLinkListQuery   |
| Scheduling          | Create Closing Day                          | SCH_CreateClosing-<br>Day                |
| Scheduling          | Update Closing Day                          | SCH_UpdateClosing-<br>Day                |
| Scheduling          | Delete Closing Day                          | SCH_DeleteClosing-<br>Day                |
| Scheduling          | Create Event Type                           | SCH_CreateEvent-<br>Type                 |
| Scheduling          | Update Event Type                           | SCH_UpdateEvent-<br>Type                 |
| Scheduling          | Delete Event Type                           | SCH_DeleteEvent-<br>Type                 |
| Scheduling          | Create Operating Day Type                   | SCH_CreateOperat-<br>ingDayType          |
| Scheduling          | Update Operating Day Type                   | SCH_UpdateOperat-<br>ingDayType          |
| Scheduling          | Delete Operating Day Type                   | SCH_DeleteOperat-<br>ingDayType          |
| Scheduling          | Recycle Settlement Instruction<br>On Demand | SCH_RecycleOn-<br>Demand                 |
| Scheduling Queries  | Event Type List Query                       | SCQ_EventTypeL-<br>istQuery              |
| Scheduling Queries  | Event Type Details Query                    | SCQ_EventTypeDe-<br>tailsQuery           |

| Class of Privileges                          | Privilege Name                              | Privilege Short Name                |
|--|---|-------------------------------------|
| Scheduling Queries                           | Operating Day Type List Query               | SCQ_OperatingDay-TypeListQuery      |
| Scheduling Queries                           | Operating Day Type Details Query            | SCQ_OperatingDay-TypeDetailsQuery   |
| Scheduling Queries                           | Closing Day Query                           | SCQ_Closing-DayQuery                |
| Scheduling Queries                           | Default Event Schedule De-tails Query       | SCQ_De-faultEventSchedDe-tailsQuery |
| Scheduling Queries                           | Current Status of the T2S settlement day    | SCQ_CurrStatusOfT2SSettlDay         |
| Scheduling Queries                           | T2S Calendar Query                          | SCQ_T2SCalendar-Query               |
| Scheduling Queries                           | T2S Diary Query                             | SCQ_T2SDiaryQuery                   |
| Securities Account Data Management           | Create Securities Account                   | SAC_CreateSecuritiesAccount         |
| Securities Account Data Management           | Update Securities Account                   | SAC_UpdateSecuritiesAccount         |
| Securities Account Data Management           | Delete Securities Account                   | SAC_DeleteSecuritiesAccount         |
| Securities Account Data Management           | Create CSD Account Link                     | SAC_CreateCSDAccountLink            |
| Securities Account Data Management           | Update CSD Account Link                     | SAC_UpdateCSDAccountLink            |
| Securities Account Data Management           | Delete CSD Account Link                     | SAC_DeleteCSDAccountLink            |
| Securities Account Data Management           | Create CMB Securities Account Link          | SAC_CreateCMBSecuritiesAccountLink  |
| Securities Account Data Management           | Delete CMB Securities Account Link          | SAC_DeleteCMBSecuritiesAccountLink  |
| Securities Account Data Management           | Update CMB Securities Account Link          | SAC_UpdateCMBSecuritiesAccountLink  |
| Securities Penalties                         | SEP_PenaltyAuditTrailQuery                  | System                              |
| Securities Penalty Reference Data Management | Create Securities Subject to Cash Penalties | SPD_CreateSecSubjecttoCashPenalties |



| Class of Privileges                          | Privilege Name                              | Privilege Short Name                |
|--|---|-------------------------------------|
| Securities Penalty Reference Data Management | Update Securities Subject to Cash Penalties | SPD_UpdateSecSubjecttoCashPenalties |
| Securities Penalty Reference Data Management | Delete Securities Subject to Cash Penalties | SPD_DeleteSecSubjecttoCashPenalties |
| Securities Penalty Reference Data Management | Delete SME Growth Market                    | SPD_DeleteS-MEGrowthMarket          |
| Securities Penalty Reference Data Management | Delete Security Penalty Rate                | SPD_DeleteSecurityPenaltyRate       |
| Securities Penalty Reference Data Management | Delete Cash Discount Penalty Rate           | SPD_DeleteCashDiscountPenaltyRate   |
| Securities Penalty Reference Data Management | Create Euro Foreign Exchange Rate           | SPD_CreateEuroForeignExchangeRate   |
| Securities Penalty Reference Data Management | Update Euro Foreign Exchange Rate           | SPD_UpdateEuroForeignExchangeRate   |
| Securities Penalty Reference Data Management | Delete Euro Foreign Exchange Rate           | SPD_DeleteEuroForeignExchangeRate   |
| Securities Penalty Reference Data Management | Create Daily Price                          | SPD_CreateDailyPrice                |
| Securities Penalty Reference Data Management | Update Daily Price                          | SPD_UpdateDailyPrice                |
| Securities Penalty Reference Data Management | Delete Daily Price                          | SPD_DeleteDailyPrice                |
| Securities Penalty Reference Data Queries    | Securities Subject to Cash Penalties Query  | SPQ_SecSubjecttoCashPenaltiesQuery  |
| Securities Penalty Reference Data Queries    | SME Growth Market Query                     | SPQ_SMEGrowthMarketQuery            |
| Securities Penalty Reference Data Queries    | Security Penalty Rate Query                 | SPQ_SecurityPenaltyRateQuery        |
| Securities Penalty Reference Data Queries    | Cash Discount Penalty Rate Query            | SPQ_CashDiscountPenaltyRateQuery    |
| Securities Penalty Reference Data Queries    | Daily Price Query                           | SPQ_DailyPriceQuery                 |
| Securities Penalty Reference Data Queries    | Euro Foreign Exchange Rate Query            | SPQ_EuroForeignExchangeRateQuery    |
| Security Data Management                     | Create Security                             | SDM_CreateSecurity                  |

| Class of Privileges      | Privilege Name                                 | Privilege Short Name                |
|--------------------------|--|-------------------------------------|
| Security Data Management | Update Security                                | SDM_UpdateSecurity                  |
| Security Data Management | Delete Security                                | SDM_DeleteSecurity                  |
| Security Data Management | Create Security CSD Link                       | SDM_CreateSecurityCSDLink           |
| Security Data Management | Update Security CSD Link                       | SDM_UpdateSecurityCSDLink           |
| Security Data Management | Delete Security CSD Link                       | SDM_DeleteSecurityCSDLink           |
| Security Data Management | Create Eligible Counterpart CSD Link           | SDM_CreateEligibleCounterpCSDLink   |
| Security Data Management | Update Eligible Counterpart CSD Link           | SDM_UpdateEligibleCounterpCSDLink   |
| Security Data Management | Delete Eligible Counterpart CSD Link           | SDM_DeleteEligibleCounterpCSDLink   |
| Security Data Queries    | Eligible Counterpart CSD List Query            | SEQ_EligibleCounterpCSDListQuery    |
| Security Data Queries    | Eligible Counterpart CSD Details Query         | SEQ_EligibleCounterpCSDDetailsQuery |
| Security Data Queries    | Securities Reference Data Query                | SEQ_SecuritiesReferDataQuery        |
| Security Data Queries    | Securities Audit Trail Query                   | SEQ_SecuritiesAudTrailQuery         |
| Security Data Queries    | ISIN List Query                                | SEQ_ISINListQuery                   |
| Security Data Queries    | Securities Deviating Nominal Query             | SEQ_SecuritiesDeviatNominQuery      |
| Security Data Queries    | Securities CSD Link Query                      | SEQ_SecuritiesCSDLinkQuery          |
| Security Data Management | Create Auto-Collateralisation Eligibility Link | SDM_CreateAuto-ColIEligibilityLink  |

| Class of Privileges      | Privilege Name  | Privilege Short Name               |
|--------------------------|---|------------------------------------|
| Security Data Management | Create Close Link   | SDM_CreateCloseLink                |
| Security Data Management | Create Securities Valuation   | SDM_CreateSecuritiesValuation      |
| Security Data Management | Delete Auto-Collateralisation Eligibility Link  | SDM_DeleteAuto-CollEligibilityLink |
| Security Data Management | Delete Close Link   | SDM_DeleteCloseLink                |
| Security Data Queries    | Auto-Collateralisation Eligibility Links Query  | SEQ_Auto-CollEligibilityLinksQuery |
| Security Data Queries    | Close Links Query   | SEQ_CloseLinksQuery                |
| Security Data Queries    | Securities Valuations Query   | SEQ_SecuritiesValuationsQuery      |
| Settlement CSD           | Unblock CoSD Securities Blocking related to cancelled CoSD Settlement Instructions on Behalf of the relevant CSD in T2S | SIC_USBBI                          |
| Settlement CSD           | Send Settlement Instruction with non-modifiable flag activated  | SIC_SINMF                          |
| Settlement CSD           | CSD Hold Settlement Instruction either on a Securities Account or on Behalf of the CSD in T2S                           | SIC_CSDHI                          |
| Settlement CSD           | Release CSD Hold Settlement Instruction either on a Securities Account or on Behalf of the CSD in T2S                   | SIC_RCSDH                          |
| Settlement CSD           | Release CSD Validation Hold Settlement Instruction either on a Securities Account or on Behalf of the CSD in T2S        | SIC_RCSDV                          |
| Settlement CSD           | Release CoSD Hold Settlement Instruction on Behalf of an Administering Party  | SIC_RCOSD                          |

| Class of Privileges | Privilege Name  | Privilege Short Name |
|---------------------|---|----------------------|
| Settlement CSD      | Amend Process Indicator of a non-modifiable Settlement Instruction on behalf of the Instructing Party of the underlying instruction | SIC_ANMBI            |
| Settlement CSD      | Hold Non-modifiable Instructions on behalf of the Instructing party of the Underlying Settlement Instruction                        | SIC_HNMBI            |
| Settlement CSD      | Release Non-modifiable Instructions on behalf of the Instructing party of the Underlying Settlement Instruction                     | SIC_RNMBI            |
| Settlement CSD      | Cancel Non-modifiable Instructions on behalf of the Instructing party of the Underlying Settlement Instruction                      | SIC_CNMBI            |
| Settlement General  | Send New Settlement Instruction/Settlement Restriction on Securities either on a Securities Account or on Behalf of an external CSD | SIG_SNDSI            |
| Settlement General  | Send new instruction using a specific Instructing Party   | SIG_SIUIP            |
| Settlement General  | Link to an Instruction/Pool Reference belonging to a specific Party   | SIG_LIPRP            |
| Settlement General  | Party Hold Settlement Instruction on a Securities Account or on Behalf of an external CSD   | SIG_PTYHI            |
| Settlement General  | Release Party Hold Settlement Instruction on a Securities Account or on Behalf of an external CSD                                   | SIG_RPTYH            |
| Settlement General  | Amend Process Indicator of a Settlement Instruction/ Settlement Restriction on Securities   | SIG_AMNPI            |

| Class of Privileges  | Privilege Name   | Privilege Short Name |
|----------------------|--|----------------------|
|                      | either on a Securities Account or on Behalf of the CSD in T2S or on Behalf of an external CSD  |                      |
| Settlement General   | Cancel Settlement Instruction / Settlement Restriction on Securities either on a Securities Account or on Behalf of the CSD in T2S, on Behalf on external CSD or on Behalf of an Administering Party | SIG_CANCI            |
| Settlement ISO Codes | Use ISO Transaction Code AUTO (Auto-Collateralisation)   | SII_UAUTO            |
| Settlement ISO Codes | Use ISO Transaction Code BYIY (BuyIn)  | SII_UBYIY            |
| Settlement ISO Codes | Use ISO Transaction Code BSBK (Buy Sell Back)  | SII_UBSBK            |
| Settlement ISO Codes | Use ISO Transaction Code CLAI (Market Claim)   | SII_UCLAI            |
| Settlement ISO Codes | Use ISO Transaction Code CNCB (Central Bank Collateral Operation)  | SII_UCNCB            |
| Settlement ISO Codes | Use ISO Transaction Code COLI (Collateral In)  | SII_UCOLI            |
| Settlement ISO Codes | Use ISO Transaction Code COLO (Collateral Out)   | SII_UCOLO            |
| Settlement ISO Codes | Use ISO Transaction Code CONV (Depository Receipt Conversion)  | SII_UCONV            |
| Settlement ISO Codes | Use ISO Transaction Code CORP (Corporate Action)   | SII_UCORP            |
| Settlement ISO Codes | Use ISO Transaction Code ETFT  | SII_UETFT            |
| Settlement ISO Codes | Use ISO Transaction Code FCTA (Factor Update)  | SII_UFCTA            |

| Class of Privileges  | Privilege Name  | Privilege Short Name |
|----------------------|---|----------------------|
| Settlement ISO Codes | Use ISO Transaction Code INSP (Move Of Stock)                           | SII_UINSP            |
| Settlement ISO Codes | Use ISO Transaction Code ISSU (Issuance)                                | SII_UISSU            |
| Settlement ISO Codes | Use ISO Transaction Code MKDW (Mark Down)                               | SII_UMKDW            |
| Settlement ISO Codes | Use ISO Transaction Code MKUP (Mark Up)                                 | SII_UMKUP            |
| Settlement ISO Codes | Use ISO Transaction Code NETT (Netting)                                 | SII_UNETT            |
| Settlement ISO Codes | Use ISO Transaction Code NSYN (Non Syndicated)                          | SII_UNSYN            |
| Settlement ISO Codes | Use ISO Transaction Code OWNI (Internal Account Transfer)               | SII_UOWNI            |
| Settlement ISO Codes | Use ISO Transaction Code PAIR (Pair Off)                                | SII_UPAIR            |
| Settlement ISO Codes | Use ISO Transaction Code PLAC (Placement)                               | SII_UPLAC            |
| Settlement ISO Codes | Use ISO Transaction Code PORT (Portfolio Move)                          | SII_UPORT            |
| Settlement ISO Codes | Use ISO Transaction Code REAL (Realignment)                             | SII_UREAL            |
| Settlement ISO Codes | Use ISO Transaction Code REBL (Rebalancing)                             | SII_UREBL            |
| Settlement ISO Codes | Use ISO Transaction Code REDI (Withdrawal)                              | SII_UREDI            |
| Settlement ISO Codes | Use ISO Transaction Code REDM (Redemption)                              | SII_UREDM            |
| Settlement ISO Codes | Use ISO Transaction Code RELE (Depository Receipt Release Cancellation) | SII_URELE            |
| Settlement ISO Codes | Use ISO Transaction Code REPU (Repo)                                    | SII_UREPU            |

| Class of Privileges  | Privilege Name   | Privilege Short Name |
|----------------------|--|----------------------|
| Codes                |  |                      |
| Settlement ISO Codes | Use ISO Transaction Code RVPO (Reverse Repurchase agreement)     | SII_URVPO            |
| Settlement ISO Codes | Use ISO Transaction Code OWNE (External Account Transfer)        | SII_UOWNE            |
| Settlement ISO Codes | Use ISO Transaction Code RODE (Return Delivery Without Matching) | SII_URODE            |
| Settlement ISO Codes | Use ISO Transaction Code SBBK (Sell Buy Back)                    | SII_USBBK            |
| Settlement ISO Codes | Use ISO Transaction Code SBRE (Borrowing Reallocation)           | SII_USBRE            |
| Settlement ISO Codes | Use ISO Transaction Code SECB (Securities Borrowing)             | SII_USECB            |
| Settlement ISO Codes | Use ISO Transaction Code SECL (Securities Lending)               | SII_USECL            |
| Settlement ISO Codes | Use ISO Transaction Code SLRE (Lending Reallocation)             | SII_USLRE            |
| Settlement ISO Codes | Use ISO Transaction Code SUBS (Subscription)                     | SII_USUBS            |
| Settlement ISO Codes | Use ISO Transaction Code SWIF (Switch From)                      | SII_USWIF            |
| Settlement ISO Codes | Use ISO Transaction Code SWIT (Switch To)                        | SII_USWIT            |
| Settlement ISO Codes | Use ISO Transaction Code SYND (Syndicate Underwriters)           | SII_USYND            |
| Settlement ISO Codes | Use ISO Transaction Code TBAC (TBA Closing)                      | SII_UTBAC            |
| Settlement ISO Codes | Use ISO Transaction Code TRAD (Trade)                            | SII_UTRAD            |
| Settlement ISO Codes | Use ISO Transaction Code TRPO (Triparty Repo)                    | SII_UTRPO            |

| Class of Privileges             | Privilege Name  | Privilege Short Name                |
|---------------------------------|---|-------------------------------------|
| Settlement ISO Codes            | Use ISO Transaction Code TRVO (Triparty Reverse Repo)               | SII_UTRVO                           |
| Settlement ISO Codes            | Use ISO Transaction Code TURN (Turnaround)                          | SII_UTURN                           |
| Static Data Queries             | Partial Settlement Threshold Query                                  | SDQ_PartialSettl-ThresholdQuery     |
| Static Data Queries             | Country Query   | SDQ_CountryQuery                    |
| Static Data Queries             | Currency Query  | SDQ_CurrencyQuery                   |
| Static Data Queries             | Tolerance Amount Query  | SDQ_Toler-anceAmountQuery           |
| Static Data Queries             | Liquidity Transfer Order of Liquidity Transfer Order Link Set Query | SDQ_LiqTranOrdOfLiqTranOrdLinkSetQ  |
| Static Data Queries             | Residual Static Data Audit Trail Query                              | SDQ_ResidualStaticDataAudTrailQuery |
| Static Data Queries             | System Entity Query   | SDQ_SystemEntityQuery               |
| T2S Dedicated Cash Account Data | Create Credit Memorandum Balance                                    | DCA_CreateCredit-MemorandumBalance  |
| T2S Dedicated Cash Account Data | Create External RTGS Account  | DCA_CreateExternalRTGSAccount       |
| T2S Dedicated Cash Account Data | Create Limit  | DCA_CreateLimit                     |
| T2S Dedicated Cash Account Data | Create Liquidity Transfer Order                                     | DCA_CreateLiquidityTransferOrder    |
| T2S Dedicated Cash Account Data | Create Liquidity Transfer Order Link Set                            | DCA_CreateLiquidityTranOrderLinkSet |
| T2S Dedicated Cash Account Data | Create T2S Dedicated Cash Account                                   | DCA_CreateT2SDedicatedCashAccount   |
| T2S Dedicated Cash Account Data | Delete Credit Memorandum Balance                                    | DCA_DeleteCredit-MemorandumBalance  |
| T2S Dedicated Cash Account Data | Delete External RTGS Account  | DCA_DeleteExternalRTGSAccount       |
| T2S Dedicated Cash Account Data | Delete Limit  | DCA_DeleteLimit                     |



| Class of Privileges                     | Privilege Name                           | Privilege Short Name                |
|---|--|-------------------------------------|
| T2S Dedicated Cash Account Data         | Delete Liquidity Transfer Order          | DCA_DeleteLiquidityTransferOrder    |
| T2S Dedicated Cash Account Data         | Delete Liquidity Transfer Order Link Set | DCA_DeleteLiquidityTranOrderLinkSet |
| T2S Dedicated Cash Account Data         | Delete T2S Dedicated Cash Account        | DCA_DeleteT2SDedicatedCashAccount   |
| T2S Dedicated Cash Account Data         | Update Credit Memorandum Balance         | DCA_UpdateCreditMemorandumBalance   |
| T2S Dedicated Cash Account Data         | Update External RTGS Account             | DCA_UpdateExternalRTGSAccount       |
| T2S Dedicated Cash Account Data         | Update Limit                             | DCA_UpdateLimit                     |
| T2S Dedicated Cash Account Data         | Update Liquidity Transfer Order          | DCA_UpdateLiquidityTransferOrder    |
| T2S Dedicated Cash Account Data         | Update Liquidity Transfer Order Link Set | DCA_UpdateLiquidityTranOrderLinkSet |
| T2S Dedicated Cash Account Data         | Update T2S Dedicated Cash Account        | DCA_UpdateT2SDedicatedCashAccount   |
| T2S Dedicated Cash Account Data Queries | CMB Details Query                        | DCQ_CMBDetailsQuery                 |
| T2S Dedicated Cash Account Data Queries | CMB List Query                           | DCQ_CMBListQuery                    |
| T2S Dedicated Cash Account Data Queries | External RTGS Account Details Query      | DCQ_ExtRTGSAccountDetailsQuery      |
| T2S Dedicated Cash Account Data Queries | External RTGS Account List Query         | DCQ_ExtRTGSAccountListQuery         |
| T2S Dedicated Cash Account Data Queries | Limit Query                              | DCQ_LimitQuery                      |
| T2S Dedicated Cash Account Data Queries | Liquidity Transfer Order Detail Query    | DCQ_LiquidityTransOrderDetailQuery  |
| T2S Dedicated Cash Account Data Queries | Liquidity Transfer Order Link Set Query  | DCQ_LiquidityTransOrderLinkSetQuery |
| T2S Dedicated Cash Account Data Queries | Liquidity Transfer Order List Query      | DCQ_LiquidityTransOrderListQuery    |

| Class of Privileges                     | Privilege Name                                       | Privilege Short Name                |
|---|--|-------------------------------------|
| T2S Dedicated Cash Account Data Queries | T2S Dedicated Cash Account Audit Trail Query         | DCQ_T2SDedic-CashAc-cAudTrailQuery  |
| T2S Dedicated Cash Account Data Queries | T2S Dedicated Cash Account List Query                | DCQ_T2SDedicated-CashAccListQuery   |
| T2S Dedicated Cash Account Data Queries | T2S Dedicated Cash Account Reference Data Query      | DCQ_T2SDedic-CashAccRefer-DataQuery |
| T2S Dedicated Cash Account Data Queries | Total amount of standing and predefined orders Query | DCQ_TotAmount-Stand+Pre-defOrdQuery |
| Ticker Management                       | Create Ticker  | TIC_CreateTicker                    |
| Ticker Management                       | Update Ticker  | TIC_UpdateTicker                    |

### 5.3.3 Privileges for T2S GUI Screens

#### 5.3.3.1 Allegement Instruction - Details Screen

△ [▶ 93]

No privileges.

#### 5.3.3.2 Allegement Instructions - Search/List Screen

△ [▶ 89]

| Privilege        | Privilege Code      | Privilege Type | Object Types | Screen Criteria |
|------------------|---------------------|----------------|--------------|-----------------|
| Allegation Query | DDQ_Allegment Query | Object         | Party        | n/a             |

#### 5.3.3.3 Amendment Cash Instruction - Details Screen

△ [▶ 404]

| Privilege   | Privilege Code                                      | Privilege Type | Object Types  | Screen Criteria |
|---|---|----------------|---|-----------------|
| Amendment Instruction for Intra-Balance Movement Audit Trail List Query | DDQ_Am<br>dInstrFor<br>IntraBal<br>MovAud<br>TrLisQ | Object         | T2S Dedicated Cash Account (analog Amendment Instruction Query for Intra Balance Movements) | n/a             |

### 5.3.3.4 Amendment Cash Instruction - New Screen

△ [▶ 409]

| Privilege  | Privilege Code | Privilege Type | Object Types               | Screen Criteria                                    |
|--|----------------|----------------|----------------------------|--|
| Link to an Instruction / Pool Reference belonging to a specific Party              | SIG_LIP<br>RP  | Object         | Party                      | Actor Reference or T2S Reference in Linkages block |
| Amend Process Indicator Settlement Restriction on Cash on a Dedicated Cash Account | CAM_AS<br>RCA  | Object         | T2S Dedicated Cash Account | T2S Dedicated Cash Account Number                  |
| Send new instruction using a specific Instructing Party                            | SIG_SIU<br>IP  | Object         | Party                      | n/a  |

### 5.3.3.5 Amendment Securities Instruction - Details Screen

△ [▶ 97]

| Privilege  | Privilege Code                                      | Privilege Type | Object Types       | Screen Criteria |
|--|---|----------------|--------------------|-----------------|
| Amendment Instruction for Intra-Position Movement or Settlement Instruction Audit Trail List Query | DDQ_Am<br>dInsIntrP<br>osMovSet<br>InsAud<br>TrLisQ | Object         | Securities Account | n/a             |

### 5.3.3.6 Amendment Securities Instruction - New Screen

△ [▶ 102]

| Privilege  | Privilege Code | Privilege Type | Object Types                | Screen Criteria                                    |
|--|----------------|----------------|-----------------------------|--|
| Send new instruction using a specific Instructing Party  | SIG_SIU<br>IP  | Object         | Party                       | n/a  |
| Link to an Instruction / Pool Reference belonging to a specific Party  | SIG_LIP<br>RP  | Object         | Party                       | Actor Reference or T2S Reference in Linkages block |
| Amend Process Indicator of a Settlement Instruction/Settlement Restriction on Securities either on a Securities Accountor or on Behalf of the CSD in T2S or on Behalf of an external CSD | SIG_AM<br>NPI  | Object         | Party<br>Securities Account | n/a  |
| Amend Process Indicator of a non-modifiable Settlement Instruction on behalf of the Instructing Party of the underlying instruction  | SIC_AN<br>MBI  | Object         | Party                       | n/a  |

### 5.3.3.7 Available Report - Current Settlement Day Cash Information (Following Settlement Day Cash Forecast) Report - Details Screen

△ [▶ 458]

| Privilege            | Privilege Code                     | Privilege Type | Object Types | Screen Criteria |
|----------------------|------------------------------------|----------------|--------------|-----------------|
| Report Details Query | RCO_<br>Report<br>Details<br>Query | System         | n/a          | n/a             |

### 5.3.3.8 Available Report - Details Screen

△ [▶ 456]

| Privilege            | Privilege Code           | Privilege Type | Object Types | Screen Criteria |
|----------------------|--------------------------|----------------|--------------|-----------------|
| Report Details Query | RCO_Report Details Query | System         | n/a          | n/a             |
| Report List Query    | RCO_Report ListQuery     | System         | n/a          | n/a             |

### 5.3.3.9 Available Report - Statement of Accounts - Details Screen

△ [▶ 463]

| Privilege            | Privilege Code           | Privilege Type | Object Types | Screen Criteria |
|----------------------|--------------------------|----------------|--------------|-----------------|
| Report Details Query | RCO_Report Details Query | System         | n/a          | n/a             |

### 5.3.3.10 Available Report - Statement of Executed Amendment Instructions for Intra-Balance Movements - Details Screen

△ [▶ 466]

| Privilege            | Privilege Code           | Privilege Type | Object Types | Screen Criteria |
|----------------------|--------------------------|----------------|--------------|-----------------|
| Report Details Query | RCO_Report Details Query | System         | n/a          | n/a             |

### 5.3.3.11 Available Report - Statement of Executed Amendment Instructions for Intra-Position Movements and Settlement Instructions - Details Screen

△ [▶ 471]

| Privilege            | Privilege Code           | Privilege Type | Object Types | Screen Criteria |
|----------------------|--------------------------|----------------|--------------|-----------------|
| Report Details Query | RCO_Report Details Query | System         | n/a          | n/a             |

### 5.3.3.12 Available Report - Statement of Executed Cancellation Instructions for Intra-Balance Movements - Details Screen

△ [▶ 480]

| Privilege            | Privilege Code           | Privilege Type | Object Types | Screen Criteria |
|----------------------|--------------------------|----------------|--------------|-----------------|
| Report Details Query | RCO_Report Details Query | System         | n/a          | n/a             |

### 5.3.3.13 Available Report - Statement of Executed Cancellation Instructions for Intra-Position Movements and Settlement Instructions - Details Screen

△ [▶ 484]

| Privilege            | Privilege Code           | Privilege Type | Object Types | Screen Criteria |
|----------------------|--------------------------|----------------|--------------|-----------------|
| Report Details Query | RCO_Report Details Query | System         | n/a          | n/a             |

### 5.3.3.14 Available Report - Statement of Holdings - Details Screen

△ [▶ 492]

| Privilege            | Privilege Code                     | Privilege Type | Object Types | Screen Criteria |
|----------------------|------------------------------------|----------------|--------------|-----------------|
| Report Details Query | RCO_<br>Report<br>Details<br>Query | System         | n/a          | n/a             |

### 5.3.3.15 Available Report - Statement of Pending Amendment Instructions for Intra-Balance Movements - Details Screen

△ [▶ 497]

| Privilege            | Privilege Code                     | Privilege Type | Object Types | Screen Criteria |
|----------------------|------------------------------------|----------------|--------------|-----------------|
| Report Details Query | RCO_<br>Report<br>Details<br>Query | System         | n/a          | n/a             |

### 5.3.3.16 Available Report - Statement of Pending Amendment Instructions for Intra-Position Movements and Settlement Instructions - Details Screen

△ [▶ 502]

| Privilege            | Privilege Code                     | Privilege Type | Object Types | Screen Criteria |
|----------------------|------------------------------------|----------------|--------------|-----------------|
| Report Details Query | RCO_<br>Report<br>Details<br>Query | System         | n/a          | n/a             |

### 5.3.3.17 Available Report - Statement of Pending Cancellation Instructions for Intra-Balance Movements - Details Screen

△ [▶ 511]

| Privilege            | Privilege Code                     | Privilege Type | Object Types | Screen Criteria |
|----------------------|------------------------------------|----------------|--------------|-----------------|
| Report Details Query | RCO_<br>Report<br>Details<br>Query | System         | n/a          | n/a             |

### 5.3.3.18 Available Report - Statement of Pending Cancellation Instructions for Intra-Position Movements and Settlement Instructions - Details Screen

△ [▶ 515]

| Privilege            | Privilege Code                     | Privilege Type | Object Types | Screen Criteria |
|----------------------|------------------------------------|----------------|--------------|-----------------|
| Report Details Query | RCO_<br>Report<br>Details<br>Query | System         | n/a          | n/a             |

### 5.3.3.19 Available Report - Statement of Pending Instructions - Details Screen

△ [▶ 523]

| Privilege            | Privilege Code                     | Privilege Type | Object Types | Screen Criteria |
|----------------------|------------------------------------|----------------|--------------|-----------------|
| Report Details Query | RCO_<br>Report<br>Details<br>Query | System         | n/a          | n/a             |

### 5.3.3.20 Available Report - Statement of Pending Intra-Balance Movements - Details Screen

△ [▶ 532]

| Privilege            | Privilege Code                     | Privilege Type | Object Types | Screen Criteria |
|----------------------|------------------------------------|----------------|--------------|-----------------|
| Report Details Query | RCO_<br>Report<br>Details<br>Query | System         | n/a          | n/a             |



### 5.3.3.21 Available Report - Statement of Pending Intra-Position Movements - Details Screen

△ [▶ 537]

| Privilege            | Privilege Code                     | Privilege Type | Object Types | Screen Criteria |
|----------------------|------------------------------------|----------------|--------------|-----------------|
| Report Details Query | RCO_<br>Report<br>Details<br>Query | System         | n/a          | n/a             |

### 5.3.3.22 Available Report - Statement of Settled Intra-Balance Movements - Details Screen

△ [▶ 542]

| Privilege            | Privilege Code                     | Privilege Type | Object Types | Screen Criteria |
|----------------------|------------------------------------|----------------|--------------|-----------------|
| Report Details Query | RCO_<br>Report<br>Details<br>Query | System         | n/a          | n/a             |

### 5.3.3.23 Available Report - Statement of Settled Intra-Position Movements - Details Screen

△ [▶ 547]

| Privilege            | Privilege Code                     | Privilege Type | Object Types | Screen Criteria |
|----------------------|------------------------------------|----------------|--------------|-----------------|
| Report Details Query | RCO_<br>Report<br>Details<br>Query | System         | n/a          | n/a             |

### 5.3.3.24 Available Report - Statement of Settlement Allegements - Details Screen

△ [▶ 550]

| Privilege            | Privilege Code           | Privilege Type | Object Types | Screen Criteria |
|----------------------|--------------------------|----------------|--------------|-----------------|
| Report Details Query | RCO_Report Details Query | System         | n/a          | n/a             |

### 5.3.3.25 Available Report - Statement of Transactions - Details Screen

△ [▶ 563]

| Privilege            | Privilege Code           | Privilege Type | Object Types | Screen Criteria |
|----------------------|--------------------------|----------------|--------------|-----------------|
| Report Details Query | RCO_Report Details Query | System         | n/a          | n/a             |

### 5.3.3.26 Available Reports - Search/List Screen

△ [▶ 451]

| Privilege         | Privilege Code       | Privilege Type | Object Types | Screen Criteria |
|-------------------|----------------------|----------------|--------------|-----------------|
| Report List Query | RCO_Report ListQuery | System         | n/a          | n/a             |

### 5.3.3.27 Available Reports – Daily Penalty List – Details Screen

△

| Privilege            | Privilege Code           | Privilege Type | Object Types | Screen Criteria |
|----------------------|--------------------------|----------------|--------------|-----------------|
| Report Details Query | RCO_Report Details Query | System         | n/a          | n/a             |

### 5.3.3.28 Available Reports – List of Modified Penalties – Details Screen

△

| Privilege            | Privilege Code                     | Privilege Type | Object Types | Screen Criteria |
|----------------------|------------------------------------|----------------|--------------|-----------------|
| Report Details Query | RCO_<br>Report<br>Details<br>Query | System         | n/a          | n/a             |

### 5.3.3.29 Available Reports – Monthly Aggregated Amounts – Details Screen

△

| Privilege            | Privilege Code                     | Privilege Type | Object Types | Screen Criteria |
|----------------------|------------------------------------|----------------|--------------|-----------------|
| Report Details Query | RCO_<br>Report<br>Details<br>Query | System         | n/a          | n/a             |

### 5.3.3.30 Broadcast - Details Screen

△ [▶ 619]

| Privilege       | Privilege Code                 | Privilege Type | Object Types | Screen Criteria |
|-----------------|--------------------------------|----------------|--------------|-----------------|
| Broadcast Query | DDQ_<br>Broad<br>cast<br>Query | System         | n/a          | n/a             |

### 5.3.3.31 Broadcast - New Screen

△ [▶ 621]

| Privilege     | Privilege Code               | Privilege Type | Object Types | Screen Criteria |
|---------------|------------------------------|----------------|--------------|-----------------|
| New Broadcast | MMA_<br>New<br>Broad<br>cast | System         | n/a          | n/a             |

### 5.3.3.32 Broadcasts - Search/List Screen

△ [▶ 616]

| Privilege       | Privilege Code                 | Privilege Type | Object Types | Screen Criteria |
|-----------------|--------------------------------|----------------|--------------|-----------------|
| Broadcast Query | DDQ_<br>Broad<br>cast<br>Query | System         | n/a          | n/a             |
| New Broadcast   | MMA_<br>New<br>Broad<br>cast   | System         | n/a          | n/a             |

### 5.3.3.33 Calender - Details Screen

△

| Privilege          | Privilege Code                | Privilege Type | Object Types | Screen Criteria |
|--------------------|-------------------------------|----------------|--------------|-----------------|
| T2S calendar query | SCQT2S-<br>Calender-<br>Query | System         | n/a          | n/a             |

### 5.3.3.34 Cancellation Cash Instruction - Details Screen

△ [▶ 416]

| Privilege   | Privilege Code                                       | Privilege Type | Object Types   | Screen Criteria                   |
|---|--|----------------|--|-----------------------------------|
| Cancellation Instruction for Intra-Balance Movement Audit Trail Details Query | DDQ_<br>CanclInstr<br>IntraBala<br>nMovAud<br>TrDetQ | Object         | T2S Dedic-<br>ated Cash<br>Account (ana-<br>log Cancell-<br>ation Instruc- | Transactional Data<br>Object Type |

| Privilege | Privilege Code | Privilege Type | Object Types                             | Screen Criteria |
|-----------|----------------|----------------|--|-----------------|
|           |                |                | tions for Intra Balance Movements Query) |                 |

### 5.3.3.35 Cancellation Cash Instruction - New Screen

△ [▶ 419]

| Privilege   | Privilege Code | Privilege Type | Object Types               | Screen Criteria            |
|---|----------------|----------------|----------------------------|----------------------------|
| Send new instruction using a specific Instructing Party           | SIG_SIU<br>IP  | Object         | Party                      | n/a                        |
| Cancel Settlement Restriction on Cash on a Dedicated Cash Account | CAM_CS<br>RCA  | Object         | T2S Dedicated Cash Account | T2S Dedicated Cash Account |

### 5.3.3.36 Cancellation Securities Instruction - Details Screen

△ [▶ 112]

| Privilege   | Privilege Code                                    | Privilege Type | Object Types       | Screen Criteria |
|---|---|----------------|--------------------|-----------------|
| Cancellation Instruction for Intra-Position Movement or Settlement Instruction Audit Trail List Query | DDQ_<br>Canclnst<br>rIntraPo<br>sMovAud<br>TrLisQ | Object         | Securities Account | n/a             |

### 5.3.3.37 Cancellation Securities Instruction - New Screen

△ [▶ 116]

| Privilege  | Privilege Code | Privilege Type | Object Types                | Screen Criteria |
|--|----------------|----------------|-----------------------------|-----------------|
| Send new instruction using a specific Instructing Party  | SIG_SIU<br>IP  | Object         | Party                       | n/a             |
| Cancel Settlement Instruction / Settlement Restriction on Securities either on a Securities Account or on Behalf of the CSD in T2S, on Behalf on external CSD or on Behalf of an Administering Party | SIG_CA<br>NCI  | Object         | Party<br>Securities Account | n/a             |
| Cancel Non-modifiable Instructions on behalf of the Instructing party of the Underlying Settlement Instruction   | SIC_CN<br>MBI  | Object         | Party                       | n/a             |

### 5.3.3.38 Cash Forecast - Details Screen

△ [▶ 331]

No privileges.

### 5.3.3.39 Cash Forecasts - Search/List Screen

△ [▶ 323]

| Privilege           | Privilege Code                    | Privilege Type | Object Types | Screen Criteria |
|---------------------|-----------------------------------|----------------|--------------|-----------------|
| Cash Forecast Query | DDQ_<br>Cash<br>Forecast<br>Query | Object         | Party        | n/a             |

### 5.3.3.40 Cash Restriction Details - Search/List Screen

△ [▶ 337]

| Privilege  | Privilege Code                       | Privilege Type | Object Types               | Screen Criteria |
|--|--------------------------------------|----------------|----------------------------|-----------------|
| T2S Dedicated Cash Account Balance Detailed Restrictions Query | DDQ_T2SDCABalanDetailedRestrictQuery | Object         | T2S Dedicated Cash Account | n/a             |

### 5.3.3.41 Collateral Value of a Security - Search/List Screen

△ [▶ 340]

| Privilege                            | Privilege Code                   | Privilege Type | Object Types | Screen Criteria |
|--------------------------------------|----------------------------------|----------------|--------------|-----------------|
| Collateral Value of a Security Query | DDQ_CollatValue-of-SecurityQuery | System         | n/a          | n/a             |

### 5.3.3.42 Collateral Value per T2S Dedicated Cash Account and Security - Search/List Screen

△ [▶ 344]

| Privilege   | Privilege Code                | Privilege Type | Object Types | Screen Criteria |
|---|-------------------------------|----------------|--------------|-----------------|
| Collateral Value per T2S Dedicated Cash Account Query | DDQ_CollatValuePerT2SDCAQuery | System         | n/a          | n/a             |

### 5.3.3.43 Settlement Day - Search/List Screen

△

| Privilege                    | Privilege Code | Privilege Type | Object Types | Screen Criteria |
|------------------------------|----------------|----------------|--------------|-----------------|
| Cumulative Billing Data List | BIQ_Cumula     | Object         | Party        | n/a             |

| Privilege               | Privilege Code   | Privilege Type | Object Types | Screen Criteria |
|-------------------------|--|----------------|--------------|-----------------|
|                         | tiveBill<br>DataList<br>Query                              |                |              |                 |
| Cumulative Billing Data | BIQ_<br>Cumulat-<br>ive Bill<br>Data-De-<br>tails<br>Query | Object         | Party        | n/a             |

### 5.3.3.44 Data Change - Details Screen

△ [▶ 611]

| Privilege                                       | Privilege Code  | Privilege Type | Object Types | Screen Criteria |
|---|---|----------------|--------------|-----------------|
| Data Changes of a Business Object List Query    | DDQ_<br>Data<br>Chan-<br>Business<br>ObjList<br>Query   | System         | n/a          | n/a             |
| Data Changes of a Business Object Details Query | DDQ_<br>Data<br>Chan-<br>Business<br>ObjDetail<br>Query | System         | n/a          | n/a             |

### 5.3.3.45 Data Changes - Search/List Screen

△ [▶ 607]



| Privilege                                       | Privilege Code  | Privilege Type | Object Types | Screen Criteria |
|---|---|----------------|--------------|-----------------|
| Data Changes of a Business Object List Query    | DDQ_<br>Data<br>Chan-<br>Business<br>ObjList<br>Query   | System         | n/a          | n/a             |
| Data Changes of a Business Object Details Query | DDQ_<br>Data<br>Chan-<br>Business<br>ObjDetail<br>Query | System         | n/a          | n/a             |

### 5.3.3.46 Hold/Release Instruction - Details Screen

△ [▶ 121]

| Privilege                                       | Privilege Code                                      | Privilege Type | Object Types   | Screen Criteria |
|---|---|----------------|--|-----------------|
| Hold/Release Instruction Audit Trail List Query | DDQ_<br>HoldRele<br>InstrAud<br>itTrail<br>LisQuery | Object         | Securities<br>Account<br>(analog<br>Hold/Re-<br>lease In-<br>struction<br>Query) | n/a             |

### 5.3.3.47 Hold/Release Instruction - New Screen

△ [▶ 125]

| Privilege   | Privilege Code | Privilege Type | Object Types                     | Screen Criteria         |
|---|----------------|----------------|----------------------------------|-------------------------|
| Party Hold Settlement Instruction on a Securities Account or on Behalf of an external CSD | SIG_PTY<br>HI  | Object         | Party<br>Securities Ac-<br>count | Party Hold<br>(flagged) |

| Privilege  | Privilege Code | Privilege Type | Object Types             | Screen Criteria                  |
|--|----------------|----------------|--------------------------|----------------------------------|
| CSD Hold Settlement Instruction either on a Securities Account or on Behalf of the CSD in T2S                    | SIC_CS<br>DHI  | Object         | Securities Account/Party | CSD Hold (flagged)               |
| Release Party Hold Settlement Instruction on a Securities Account or on Behalf of an external CSD                | SIG_RP<br>TYH  | Object         | Securities Account/Party | Party Release (flagged)          |
| Release Party Hold Auto-collateralisation Instruction on a Securities Account                                    | SIG_RP<br>TYA  | Object         | Securities Account/Party | Party Release (flagged)          |
| Release CSD Hold Settlement Instruction either on a Securities Account or on Behalf of the CSD in T2S            | SIC_RC<br>SDH  | Object         | Securities Account/Party | CSD Release (flagged)            |
| Release CSD Validation Hold Settlement Instruction either on a Securities Account or on Behalf of the CSD in T2S | SIC_RC<br>SDV  | Object         | Securities Account/Party | CSD Validation Release (flagged) |
| Release CoSD Hold Settlement Instruction on Behalf of an Administering Party                                     | SIC_RC<br>OSD  | Object         | Party                    | CoSD Release (flagged)           |
| Hold Non-modifiable Instructions on behalf of the Instructing party of the Underlying Settlement Instruction     | SIC_HN<br>MBI  | Object         | Party                    | n/a                              |

| Privilege   | Privilege Code | Privilege Type | Object Types | Screen Criteria |
|---|----------------|----------------|--------------|-----------------|
| Release Non-modifiable Instructions on behalf of the Instructing party of the Underlying Settlement Instruction | SIC_RN<br>MBI  | Object         | Party        | n/a             |

### 5.3.3.48 Immediate Liquidity Transfer Order - New Screen

△ [▶ 386]

| Privilege                   | Privilege Code                               | Privilege Type | Object Types                                | Screen Criteria |
|-----------------------------|--|----------------|---|-----------------|
| Send New Liquidity Transfer | CAM_<br>Send<br>New<br>Liquidity<br>Transfer | Object         | Party<br>T2S Dedic-<br>ated Cash<br>Account | n/a             |

### 5.3.3.49 Immediate Liquidity Transfer Order- Details Screen

△ [▶ 381]

| Privilege   | Privilege Code                                      | Privilege Type | Object Types                       | Screen Criteria |
|---|---|----------------|------------------------------------|-----------------|
| Immediate Liquidity Transfer Order Detail Query           | DDQ_<br>ImmedLiq<br>uidTrans<br>OrderDet<br>Query   | Object         | T2S Dedic-<br>ated Cash<br>Account | n/a             |
| Immediate Liquidity Transfer Order Audit Trail List Query | DDQ_<br>ImmedLiq<br>uidTrans<br>OrderAud<br>TrListQ | Object         | T2S Dedic-<br>ated Cash<br>Account | n/a             |

### 5.3.3.50 Immediate Liquidity Transfer Orders - Search/List Screen

△ [▶ 373]

| Privilege                                       | Privilege Code                     | Privilege Type | Object Types               | Screen Criteria |
|---|------------------------------------|----------------|----------------------------|-----------------|
| Immediate Liquidity Transfer Order List Query   | DDQ_ImmedLiquidTransOrderListQuery | Object         | T2S Dedicated Cash Account | n/a             |
| Immediate Liquidity Transfer Order Detail Query | DDQ_ImmedLiquidTransOrderDetQuery  | Object         | T2S Dedicated Cash Account | n/a             |

### 5.3.3.51 Inbound File - Details Screen

△ [▶ 625]

| Privilege                   | Privilege Code               | Privilege Type | Object Types | Screen Criteria |
|-----------------------------|------------------------------|----------------|--------------|-----------------|
| Inbound Files Details Query | DDQ_InboundFilesDetailsQuery | System         | n/a          | n/a             |

### 5.3.3.52 Inbound Files - Search/List Screen

△ [▶ 622]

| Privilege                | Privilege Code            | Privilege Type | Object Types | Screen Criteria |
|--------------------------|---------------------------|----------------|--------------|-----------------|
| Inbound Files List Query | DDQ_InboundFilesListQuery | System         | n/a          | n/a             |

### 5.3.3.53 Inbound Message - Details Screen

△ [▶ 635]

| Privilege                     | Privilege Code              | Privilege Type | Object Types | Screen Criteria |
|-------------------------------|-----------------------------|----------------|--------------|-----------------|
| Inbound Message Details Query | DDQ_InboundMessDetailsQuery | System         | n/a          | n/a             |

### 5.3.3.54 Inbound Messages - Search/List Screen

△ [▶ 628]

| Privilege                  | Privilege Code           | Privilege Type | Object Types | Screen Criteria |
|----------------------------|--------------------------|----------------|--------------|-----------------|
| Inbound Message List Query | DDQ_InboundMessListQuery | System         | n/a          | n/a             |

### 5.3.3.55 Insolvency procedure Settlement Instructions - Search/List Screen

△ [▶ 269]

| Privilege  | Privilege Code                                    | Privilege Type | Object Types              | Screen Criteria |
|--|---|----------------|---------------------------|-----------------|
| Settlement Instruction Matched and Accepted Status Query Privilege | DDQ_SettlementInstructionMatchAcceptedStatusQuery | Object         | Securities Account, Party | n/a             |

### 5.3.3.56 Intra-Balance Movement - Details Screen

△ [▶ 429]

| Privilege                                     | Privilege Code      | Privilege Type | Object Types               | Screen Criteria |
|---|---------------------|----------------|----------------------------|-----------------|
| Intra-Balance Movement Audit Trail List Query | DDQ_IntraBalanceMov | Object         | T2S Dedicated Cash Account | n/a             |

| Privilege | Privilege Code       | Privilege Type | Object Types | Screen Criteria |
|-----------|----------------------|----------------|--------------|-----------------|
|           | Audit TrailLis Query |                |              |                 |

### 5.3.3.57 Intra-Balance Movement - New Screen

△ [▶ 436]

| Privilege   | Privilege Code | Privilege Type | Object Types               | Screen Criteria                                     |
|---|----------------|----------------|----------------------------|---|
| Send New Settlement Restriction on Cash on a Dedicated Cash Account   | CAM_SN DRC     | Object         | T2S Dedicated Cash Account | Dedicated Cash Account Number (just for the object) |
| Unblock CoSD Cash Blocking related to cancelled CoSD Settlement Instructions on Behalf of the relevant CSD in T2S | CAM_UC BBI     | Object         | Party                      | n/a   |
| Link to an Instruction/ Pool Reference belonging to a specific Party  | SIG_LIP RP     | Object         | Party                      | Actor Reference or T2S Reference in Linkages block  |
| Send new instruction using a specific Instructing Party   | SIG_SIU IP     | Object         | Party                      | n/a   |

### 5.3.3.58 Intra-Balance Movements - Search/List Screen

△ [▶ 422]

| Privilege                     | Privilege Code           | Privilege Type | Object Types               | Screen Criteria |
|-------------------------------|--------------------------|----------------|----------------------------|-----------------|
| Intra-Balance Movements Query | DDQ_IntraBalanceMovQuery | Object         | T2S Dedicated Cash Account | n/a             |

### 5.3.3.59 Intra-Position Movement - Details Screen

△ [▶ 143]

| Privilege                      | Privilege Code       | Privilege Type | Object Types       | Screen Criteria |
|--------------------------------|----------------------|----------------|--------------------|-----------------|
| Intra-Position Movements Query | DDQ_IntraPosMovQuery | Object         | Securities Account | n/a             |

### 5.3.3.60 Intra-Position Movement - New Screen

△ [▶ 150]

| Privilege   | Privilege Code | Privilege Type | Object Types       | Screen Criteria                                    |
|---|----------------|----------------|--------------------|--|
| Send New Settlement Instruction/Settlement Restriction on Securities either on a Securities Account or on Behalf of an external CSD | SIG_SN DSI     | Object         | Securities Account | Securities Account (just for the object)           |
| Unblock CoSD Securities Blocking related to cancelled CoSD Settlement Instructions on Behalf of the relevant CSD in T2S             | SIC_US BBI     | Object         | Party              | n/a  |
| Link to an Instruction / Pool Reference belonging to a specific Party   | SIG_LIP RP     | Object         | Party              | Actor Reference or T2S Reference in Linkages block |
| Send new instruction using a specific Instructing Party   | SIG_SIU IP     | Object         | Party              | n/a  |

### 5.3.3.61 Intra-Position Movements - Search/List Screen

△ [▶ 136]

| Privilege                      | Privilege Code               | Privilege Type | Object Types            | Screen Criteria |
|--------------------------------|------------------------------|----------------|-------------------------|-----------------|
| Intra-Position Movements Query | DDQ_Int<br>raPosMov<br>Query | Object         | Securities Ac-<br>count | n/a             |

### 5.3.3.62 Limit Utilisation - Search/List Screen

△ [▶ 348]

| Privilege               | Privilege Code                        | Privilege Type | Object Types | Screen Criteria |
|-------------------------|---------------------------------------|----------------|--------------|-----------------|
| Limit Utilisation Query | DDQ_<br>LimitUti<br>lisation<br>Query | System         | n/a          | n/a             |

### 5.3.3.63 Limit Utilisation Journal - Search/List Screen

△ [▶ 352]

| Privilege                       | Privilege Code                                   | Privilege Type | Object Types | Screen Criteria |
|---------------------------------|--|----------------|--------------|-----------------|
| Limit Utilisation Journal Query | DDQ_<br>LimitUti<br>lisation<br>Journal<br>Query | System         | n/a          | n/a             |

### 5.3.3.64 Maintenance Cash Instructions – Search/List Screen

△ [▶ 447]



| Privilege   | Privilege Code  | Privilege Type | Object Types                       | Screen Criteria  |
|---|---|----------------|------------------------------------|--|
| Cancellation Instructions for Intra-Balance Movements Query | DDQ_<br>CanclInstr<br>Intra<br>BalanMov<br>Query        | Object         | T2S Dedic-<br>ated Cash<br>Account | 'Maintenance In-<br>struction Type'.<br>Mandatory field<br>that identify the<br>kind of Mainten-<br>ance Instruction<br>queried. |
| Maintenance Instruction for Intra-Balance Movements Query   | DDQ_<br>Maint<br>InstrFor<br>IntraBa<br>lanMov<br>Quer  | Object         | T2S Dedic-<br>ated Cash<br>Account | 'Maintenance In-<br>struction Type'.<br>Mandatory field<br>that identify the<br>kind of Mainten-<br>ance Instruction<br>queried. |
| Amendment Instruction Query for Intra-Balance Movements     | DDQ_<br>Amend<br>Instr<br>Query<br>ForIntra<br>BalanMov | Object         | T2S Dedic-<br>ated Cash<br>Account | 'Maintenance In-<br>struction Type'.<br>Mandatory field<br>that identify the<br>kind of Mainten-<br>ance Instruction<br>queried. |

### 5.3.3.65 Maintenance Securities Instructions – Search/ List Screen

△ [▶ 163]

| Privilege   | Privilege Code                                       | Privilege Type | Object Types            | Screen Criteria  |
|---|--|----------------|-------------------------|--|
| Cancellation Instruction Query for Intra-Position Movements and Settlement Instructions | DDQ_<br>CanclInstr<br>ForSI+Int<br>raPosMov<br>Query | Object         | Securities Ac-<br>count | 'Maintenance In-<br>struction Type'.<br>Mandatory field<br>that identify the<br>kind of Mainten-<br>ance Instruction<br>queried. |

| Privilege  | Privilege Code                      | Privilege Type | Object Types       | Screen Criteria   |
|--|-------------------------------------|----------------|--------------------|---|
| Maintenance for Intra-Position Movements and Settlement Instructions Query           | DDQ_MaintForIntraPosMov+SettlInstrQ | Object         | Securities Account | 'Maintenance Instruction Type' Mandatory field that identify the kind of Maintenance Instruction queried. |
| Amendment Instruction Query for Intra-Position Movements and Settlement Instructions | DDQ_AmendInstrQIntraPosMov+SetInstr | Object         | Securities Account | 'Maintenance Instruction Type' Mandatory field that identify the kind of Maintenance Instruction queried. |

### 5.3.3.66 Outbound File - Details Screen

△ [▶ 643]

| Privilege                    | Privilege Code                | Privilege Type | Object Types | Screen Criteria |
|------------------------------|-------------------------------|----------------|--------------|-----------------|
| Outbound Files Details Query | DDQ_OutboundFilesDetailsQuery | System         | n/a          | n/a             |
| Resend Communication         | MMA_ResendCommunication       | Object         | Party        | 'Resend' button |

### 5.3.3.67 Outbound Files - Search/List Screen

△ [▶ 640]

| Privilege                 | Privilege Code             | Privilege Type | Object Types | Screen Criteria |
|---------------------------|----------------------------|----------------|--------------|-----------------|
| Outbound Files List Query | DDQ_OutboundFilesListQuery | System         | n/a          | n/a             |

| Privilege                    | Privilege Code                                | Privilege Type | Object Types | Screen Criteria |
|------------------------------|---|----------------|--------------|-----------------|
| Outbound Files Details Query | DDQ_<br>Outbound<br>Files<br>Details<br>Query | System         | n/a          | n/a             |
| Resend Communication         | MMA_<br>Resend<br>Communi-<br>cation          | Object         | Party        | 'Resend' button |

### 5.3.3.68 Outbound Message - Details Screen

△ [▶ 653]

| Privilege                      | Privilege Code                           | Privilege Type | Object Types | Screen Criteria |
|--------------------------------|--|----------------|--------------|-----------------|
| Outbound Message Details Query | DDQ_<br>Outbound<br>MessDet<br>ailsQuery | System         | n/a          | n/a             |
| Resend Communication           | MMA_<br>Resend<br>Communi-<br>cation     | Object         | Party        | 'Resend' button |

### 5.3.3.69 Outbound Messages - Search/List Screen

△ [▶ 645]

| Privilege                      | Privilege Code                               | Privilege Type | Object Types | Screen Criteria |
|--------------------------------|--|----------------|--------------|-----------------|
| Outbound Message List Query    | DDQ_<br>Outbound<br>MessList<br>Query        | System         | n/a          | n/a             |
| Outbound Message Details Query | DDQ_<br>Outbound<br>Mess<br>Details<br>Query | System         | n/a          | n/a             |

## Outstanding Auto-Collateralisation Credits - Search/List Screen

| Privilege            | Privilege Code            | Privilege Type | Object Types | Screen Criteria |
|----------------------|---------------------------|----------------|--------------|-----------------|
| Resend Communication | MMA_ Resend Communication | Object         | Party        | 'Resend' button |

## 5.3.3.70 Outstanding Auto-Collateralisation Credits - Search/List Screen

△ [▶ 392]

| Privilege                                       | Privilege Code                          | Privilege Type | Object Types | Screen Criteria |
|---|---|----------------|--------------|-----------------|
| Outstanding Auto-Collateralisation Credit Query | DDQ_ Outstanding Auto-Coll Credit Query | System         | n/a          | n/a             |

## 5.3.3.71 Overall Liquidity - Search/List Screen

△ [▶ 396]

| Privilege                   | Privilege Code                   | Privilege Type | Object Types | Screen Criteria |
|-----------------------------|----------------------------------|----------------|--------------|-----------------|
| T2S Overall Liquidity Query | DDQ_ T2S Overall Liquidity Query | Object         | Party        | n/a             |

## 5.3.3.72 Penalty – Search/List Screen

△

| Privilege                    | Privilege Code       | Privilege Type | Object Types | Screen Criteria |
|------------------------------|----------------------|----------------|--------------|-----------------|
| Penalty List Query Privilege | SPQ_PenaltyListQuery | System         | n/a          | n/a             |

| Privilege                                | Privilege Code  | Privilege Type | Object Types                     | Screen Criteria |
|--|---|----------------|----------------------------------|-----------------|
| Settlement Instruction Audit Trail Query | DDQ_Set-<br>t-<br>tllnstruct<br>A<br>uit_Trail<br>Query | Object         | Securities Ac-<br>count<br>Party | n/a             |

### 5.3.3.73 Penalty – Details Screen

△

| Privilege             | Privilege Code                       | Privilege Type | Object Types | Screen Criteria |
|-----------------------|--------------------------------------|----------------|--------------|-----------------|
| Penalty Details Query | SPQ_Pe<br>naltyDe-<br>tailsQuer<br>y | System         | n/a          | n/a             |

### 5.3.3.74 Monthly Net Penalty Amounts – Search/List Screen

△

| Privilege                | Privilege Code                                    | Privilege Type | Object Types | Screen Criteria |
|--------------------------|---|----------------|--------------|-----------------|
| Monthly Net Amount Query | SPQ_Mo<br>ntlyNet-<br>Pen-<br>altyAmou<br>ntQuery | System         | n/a          | n/a             |

### 5.3.3.75 Penalty Removal Screen

△

| Privilege                 | Privilege Code                          | Privilege Type | Object Types | Screen Criteria |
|---------------------------|---|----------------|--------------|-----------------|
| Modification of penalties | SEP_Mo<br>dific-<br>tionOfPe<br>nalties | System         | n/a          | Edit mode       |

| Privilege                                | Privilege Code           | Privilege Type | Object Types             | Screen Criteria |
|--|--------------------------|----------------|--------------------------|-----------------|
| Settlement Instruction Audit Trail Query | Securities Account Party | n/a            | Securities Account Party | n/a             |

### 5.3.3.76 Penalty Re-allocation Screen

△

| Privilege                                | Privilege Code              | Privilege Type | Object Types             | Screen Criteria |
|--|-----------------------------|----------------|--------------------------|-----------------|
| Modification of penalties                | SEP_ModificationOfPenalties | System         | n/a                      | Edit mode       |
| Settlement Instruction Audit Trail Query | Securities Account Party    | n/a            | Securities Account Party | n/a             |

### 5.3.3.77 Penalty Switch Screen

△

| Privilege                                | Privilege Code              | Privilege Type | Object Types             | Screen Criteria |
|--|-----------------------------|----------------|--------------------------|-----------------|
| Modification of penalties                | SEP_ModificationOfPenalties | System         | n/a                      | Edit mode       |
| Settlement Instruction Audit Trail Query | Securities Account Party    | n/a            | Securities Account Party | n/a             |

### 5.3.3.78 Resend Communication Screen

△ [▶ 657]

| Privilege            | Privilege Code          | Privilege Type | Object Types | Screen Criteria |
|----------------------|-------------------------|----------------|--------------|-----------------|
| Resend Communication | MMA_ResendCommunication | Object         | Party        | n/a             |

### 5.3.3.79 Revisions/Audit Trail - List Screen

△ [▶ 661]

| Privilege   | Privilege Code                           | Privilege Type | Object Types               | Screen Criteria |
|---|--|----------------|----------------------------|-----------------|
| Amendment Instruction for Intra-Position Movement or Settlement Instruction Audit Trail List Query    | DDQ_Am-dInsIntr-PosMov-SetIn-sAudTrL-isQ | Object         | Securities Account         | n/a             |
| Amendment Instruction for Intra-Balance Movement Audit Trail List Query                               | DDQ_Am-dInstrFor-IntraBal-MovAudTrLisQ   | Object         | T2S Dedicated Cash Account | n/a             |
| Cancellation Instruction for Intra-Balance Movement Audit Trail List Query                            | DDQ_Can-clnstrIntra-Balan-MovAudTrLisQ   | Object         | Securities Account         | n/a             |
| Cancellation Instruction for Intra-Position Movement or Settlement Instruction Audit Trail List Query | DDQ_Can-clnstrIntra-Pos-MovAudTrLisQ     | Object         | T2S Dedicated Cash Account | n/a             |
| Immediate Liquidity Transfer Order Audit Trail List Query   | DDQ_Imm-edLi-liquidTransOrderAudTrListQ  | Object         | T2S Dedicated Cash Account | n/a             |

| Privilege                                      | Privilege Code                         | Privilege Type | Object Types                | Screen Criteria                          |
|--|--|----------------|-----------------------------|--|
| Intra-Balance Movement Audit Trail List Query  | DDQ_IntraBalan-MovAudit-Trail-LisQuery | Object         | T2S Dedicated Cash Account  | n/a                                      |
| Intra-Position Movement Audit Trail List Query | DDQ_IntraPos-MovAudit-Trail-ListQuery  | Object         | Securities Account          | n/a                                      |
| Party Audit Trail Query                        | PDQ_PartyAud Trail Query               | Object         | Party                       | Object Type = Party                      |
| Securities Account Audit Trail Query           | SAQ_SecuritiesAcc AudTrail Query       | Object         | Securities Account          | Object Type = Securities Account         |
| Securities Audit Trail Query                   | SEQ_SecuritiesAud Trail Query          | Object         | Security                    | Object Type = Securities                 |
| Settlement Instruction Audit Trail Query       | DDQ_SettlInstructAuit-TrailQuery       | Object         | Securities Account<br>Party | n/a                                      |
| T2S Dedicated Cash Account Audit Trail Query   | DCQ_T2S Dedic CashAcc AudTrail Query   | Object         | T2S Dedicated Cash Account  | Object Type = T2S Dedicated Cash Account |



| Privilege                              | Privilege Code                             | Privilege Type | Object Types | Screen Criteria  |
|--|--|----------------|--------------|--|
| Residual Static Data Audit Trail Query | SDQ_Residual Static Data Audit Trail Query | System         | n/a          | Object Type is not Party, T2S Dedicated Cash Account, Securities or Securities Account |

### 5.3.3.80 Securities Position - Details Screen

△ [▶ 173]

No privileges.

### 5.3.3.81 Securities Positions - Search/List Screen

△ [▶ 168]

| Privilege                         | Privilege Code                        | Privilege Type | Object Types       | Screen Criteria |
|-----------------------------------|---------------------------------------|----------------|--------------------|-----------------|
| Securities Account Position Query | DDQ_Securities Account Position Query | Object         | Securities Account | n/a             |

### 5.3.3.82 Securities Postings - Search/List Screen

△ [▶ 81]

| Privilege                | Privilege Code               | Privilege Type | Object Types       | Screen Criteria |
|--------------------------|------------------------------|----------------|--------------------|-----------------|
| Securities Posting Query | DDQ_Securities Posting Query | Object         | Securities Account | n/a             |

### 5.3.3.83 Securities Restriction Details - Search/List Screen

△ [▶ 85]

| Privilege  | Privilege Code                      | Privilege Type | Object Types       | Screen Criteria |
|--|-------------------------------------|----------------|--------------------|-----------------|
| Securities Position Detailed Restriction Details Query | DDQ_SecurPosDetailedRestrDetailsQue | Object         | Securities Account | n/a             |

### 5.3.3.84 Settlement Instruction - Details Screen

△ [▶ 191]

| Privilege                    | Privilege Code         | Privilege Type | Object Types              | Screen Criteria |
|------------------------------|------------------------|----------------|---------------------------|-----------------|
| Settlement Instruction Query | DDQ_SettlInstructQuery | Object         | Securities Account, Party | n/a             |

### 5.3.3.85 Settlement Instruction - New Screen

△

| Privilege   | Privilege Code | Privilege Type | Object Types                | Screen Criteria                          |
|---|----------------|----------------|-----------------------------|--|
| Send New Settlement Instruction/Settlement Restriction on Securities either on a Securities Account or on Behalf of an external CSD | SIG_SNDSI      | Object         | Securities Account<br>Party | Securities Account (just for the object) |
| Send Settlement Instruction with non-modifiable flag activated  | SIC_SINMF      | System         | n/a                         | Allowed Modification Flag= No            |

| Privilege   | Privilege Code | Privilege Type | Object Types                | Screen Criteria                                    |
|---|----------------|----------------|-----------------------------|--|
| Link to an Instruction / Pool Reference belonging to a specific Party                         | SIG_LIP<br>RP  | Object         | Party                       | Actor Reference or T2S Reference in Linkages block |
| Party Hold Settlement Instruction on a Securities Account or on Behalf of an external CSD     | SIG_PTY<br>HI  | Object         | Securities Account<br>Party | Party Hold (flagged)                               |
| CSD Hold Settlement Instruction either on a Securities Account or on Behalf of the CSD in T2S | SIC_CS<br>DHI  | Object         | Securities Account<br>Party | CSD Hold (flagged)                                 |
| Use ISO Transaction Code AUTO (Auto-Collateralisation)  | SII_UAU<br>TO  | System         | n/a                         | Securities Transaction Type                        |
| Use ISO Transaction Code BYIY (BuyIn)   | SII_UBYI<br>Y  | System         | n/a                         | Securities Transaction Type                        |
| Use ISO Transaction Code BSBK (Buy Sell Back)   | SII_UBS<br>BK  | System         | n/a                         | Securities Transaction Type                        |
| Use ISO Transaction Code CLAI (Market Claim)  | SII_UCL<br>AI  | System         | n/a                         | Securities Transaction Type                        |
| Use ISO Transaction Code CNCB (Central Bank Collateral Operation)                             | SII_UCN<br>CB  | System         | n/a                         | Securities Transaction Type                        |
| Use ISO Transaction Code COLI (Collateral In)   | SII_UCO<br>LI  | System         | n/a                         | Securities Transaction Type                        |
| Use ISO Transaction Code COLO (Collateral Out)  | SII_UCO<br>LO  | System         | n/a                         | Securities Transaction Type                        |

| Privilege   | Privilege Code | Privilege Type | Object Types | Screen Criteria             |
|---|----------------|----------------|--------------|-----------------------------|
| Use ISO Transaction Code CONV (Depository Receipt Conversion) | SII_UCO NV     | System         | n/a          | Securities Transaction Type |
| Use ISO Transaction Code CORP (Corporate Action)              | SII_UCO RP     | System         | n/a          | Securities Transaction Type |
| Use ISO Transaction Code ETFT (Exchange Traded Funds)         | SII_UET FT     | System         | n/a          | Securities Transaction Type |
| Use ISO Transaction Code FCTA (Factor Update)                 | SII_UFC TA     | System         | n/a          | Securities Transaction Type |
| Use ISO Transaction Code INSP (Move Of Stock)                 | SII_UIN SP     | System         | n/a          | Securities Transaction Type |
| Use ISO Transaction Code ISSU (Issuance)                      | SII_UIS SU     | System         | n/a          | Securities Transaction Type |
| Use ISO Transaction Code MKDW (Mark Down)                     | SII_UMK DW     | System         | n/a          | Securities Transaction Type |
| Use ISO Transaction Code MKUP (Mark Up)                       | SII_UMK UP     | System         | n/a          | Securities Transaction Type |
| Use ISO Transaction Code NETT (Netting)                       | SII_UNE TT     | System         | n/a          | Securities Transaction Type |
| Use ISO Transaction Code NSYN (Non Syndicated)                | SII_UNS YN     | System         | n/a          | Securities Transaction Type |
| Use ISO Transaction Code OWNE (External Account Transfer)     | SII_UOW NE     | System         | n/a          | Securities Transaction Type |
| Use ISO Transaction Code OWNI (Internal Account Transfer)     | SII_UOW NI     | System         | n/a          | Securities Transaction Type |
| Use ISO Transaction Code PAIR (Pair Off)                      | SII_UPA IR     | System         | n/a          | Securities Transaction Type |

| Privilege   | Privilege Code | Privilege Type | Object Types | Screen Criteria             |
|---|----------------|----------------|--------------|-----------------------------|
| Use ISO Transaction Code PLAC (Placement)                               | SII_UPLAC      | System         | n/a          | Securities Transaction Type |
| Use ISO Transaction Code PORT (Portfolio Move)                          | SII_UPORT      | System         | n/a          | Securities Transaction Type |
| Use ISO Transaction Code REAL (Realignment)                             | SII_UREAL      | System         | n/a          | Securities Transaction Type |
| Use ISO Transaction Code REDI (Withdrawal)                              | SII_URED       | System         | n/a          | Securities Transaction Type |
| Use ISO Transaction Code REDM (Redemption)                              | SII_UREDM      | System         | n/a          | Securities Transaction Type |
| Use ISO Transaction Code RELE (Depository Receipt Release Cancellation) | SII_URELE      | System         | n/a          | Securities Transaction Type |
| Use ISO Transaction Code REPU (Repo)                                    | SII_UREPU      | System         | n/a          | Securities Transaction Type |
| Use ISO Transaction Code RODE (Return Delivery Without Matching)        | SII_URODE      | System         | n/a          | Securities Transaction Type |
| Use ISO Transaction Code RVPO (Reverse Repurchase agreement)            | SII_URVPO      | System         | n/a          | Securities Transaction Type |
| Use ISO Transaction Code SBBK (Sell Buy Back)                           | SII_USBBK      | System         | n/a          | Securities Transaction Type |
| Use ISO Transaction Code SBRE (Borrowing Reallocation)                  | SII_USBRE      | System         | n/a          | Securities Transaction Type |

| Privilege   | Privilege Code | Privilege Type | Object Types | Screen Criteria             |
|---|----------------|----------------|--------------|-----------------------------|
| Use ISO Transaction Code SECB (Securities Borrowing)    | SII_USE CB     | System         | n/a          | Securities Transaction Type |
| Use ISO Transaction Code SECL (Securities Lending)      | SII_USE CL     | System         | n/a          | Securities Transaction Type |
| Use ISO Transaction Code SLRE (Lending Reallocation)    | SII_USL RE     | System         | n/a          | Securities Transaction Type |
| Use ISO Transaction Code SUBS (Subscription)            | SII_USU BS     | System         | n/a          | Securities Transaction Type |
| Use ISO Transaction Code SWIF (Switch From)             | SII_USWI F     | System         | n/a          | Securities Transaction Type |
| Use ISO Transaction Code SWIT (Switch To)               | SII_USWI T     | System         | n/a          | Securities Transaction Type |
| Use ISO Transaction Code SYND (Syndicate Underwriters)  | SII_USY ND     | System         | n/a          | Securities Transaction Type |
| Use ISO Transaction Code TBAC (TBA Closing)             | SII_UTB AC     | System         | n/a          | Securities Transaction Type |
| Use ISO Transaction Code TRAD (Trade)                   | SII_UTR AD     | System         | n/a          | Securities Transaction Type |
| Use ISO Transaction Code TRPO (Triparty Repo)           | SII_UTR PO     | System         | n/a          | Securities Transaction Type |
| Use ISO Transaction Code TRVO (Triparty Reverse Repo)   | SII_UTR VO     | System         | n/a          | Securities Transaction Type |
| Use ISO Transaction Code TURN (Turn-around)             | SII_UTU RN     | System         | n/a          | Securities Transaction Type |
| Send new instruction using a specific Instructing Party | SIG_SIU IP     | Object         | Party        | n/a                         |

### 5.3.3.86 Settlement Instructions - Search/List Screen

△ [▶ 176]

| Privilege                    | Privilege Code          | Privilege Type | Object Types              | Screen Criteria |
|------------------------------|-------------------------|----------------|---------------------------|-----------------|
| Settlement Instruction Query | DDQ_SettlInstruct Query | Object         | Securities Account, Party | n/a             |

### 5.3.3.87 Status History - Details Screen

△ [▶ 266]

No privileges.

### 5.3.3.88 T2S DCA Balance - Details Screen

△ [▶ 361]

No privileges.

### 5.3.3.89 T2S DCA Balances - Search/List Screen

△ [▶ 357]

| Privilege                                | Privilege Code                         | Privilege Type | Object Types               | Screen Criteria |
|--|--|----------------|----------------------------|-----------------|
| T2S Dedicated Cash Account Balance Query | DDQ_T2SDedicated CashAcc Balance Query | Object         | T2S Dedicated Cash Account | n/a             |

### 5.3.3.90 T2S DCA Postings - Search/List Screen

△ [▶ 363]

| Privilege                                | Privilege Code   | Privilege Type | Object Types               | Screen Criteria |
|--|------------------|----------------|----------------------------|-----------------|
| T2S Dedicated Cash Account Posting Query | DDQ_T2SDedicated | Object         | T2S Dedicated Cash Account | n/a             |

Total Amount of Standing/Predefined Liquidity Transfer Orders - Search/List Screen

| Privilege | Privilege Code        | Privilege Type | Object Types | Screen Criteria |
|-----------|-----------------------|----------------|--------------|-----------------|
|           | CashAcc Posting Query |                |              |                 |

### 5.3.3.91 Total Amount of Standing/Predefined Liquidity Transfer Orders - Search/List Screen

△ [▶ 400]

| Privilege  | Privilege Code                    | Privilege Type | Object Types          | Screen Criteria |
|--|-----------------------------------|----------------|-----------------------|-----------------|
| Total Amount of Standing and Predefined Orders Query | DCQ_TotAmountStand+PredefOrdQuery | Object         | T2S Dedicated Account | n/a             |

### 5.3.3.92 Total Collateral Value per T2S Dedicated Cash Account - Search/List Screen

△ [▶ 369]

| Privilege   | Privilege Code                     | Privilege Type | Object Types | Screen Criteria |
|---|------------------------------------|----------------|--------------|-----------------|
| Total Collateral Value per T2S Dedicated Cash Account Query | DDQ_TotalCollatValuePerT2SDCAQuery | System         | n/a          | n/a             |

### 5.3.4 Privilege Classes for LTSI Screens

| Class of Privileges | Privilege Name                                    | Privilege Short Name |
|---------------------|---|----------------------|
| Other               | Long Term Statistical Information – Advanced User | ARM_GrantPrivilege   |
| Other               | Long Term Statistical Information Access          | LTSI Access          |



### 5.3.5 Privileges for LTSI Screens

LTSI user profiles are created based on the Static data Privileges and also on the Party identifiers, stored in Static Data Users, and their party types associated. LTSI can also provide access to internal users, not sent by Static Data.

Possible LTSI privileges can be:

- NCB end user: Static Data Party type= NCB, Static Data privilege= GFS user profile: Basic Statistical User
- CSD end user: Static Data Party type= CSD, Static Data privilege= GFS user profile: Basic Statistical User
- CSD participant end user: Static Data Party type= CSD, Static Data privilege= GFS user profile: Basic Statistical User
- External CSD end user: Static Data Party type= External CSD, Static Data privilege= GFS user profile: Basic Statistical User
- NCB analyst: Static Data Party type=NCB, Static Data privilege= and eventually also, GFS user profile: Basic Statistical User and Advanced Statistical User
- CSD analyst: Static Data Party type=CSD, Static Data privilege= and eventually also , GFS user profile: Basic Statistical User and Advanced Statistical User
- LTSI super user: Not sent by Static Data, Internal user, GFS user profile: Basic Statistical User and Advanced Statistical User
- Administrator: Not sent by Static Data, Internal user, GFS user profile: Statistical Workspace administrator

The party type has an impact on the final LTSI privilege: for instance, a CSD Participant or external CSD can only be an end user, but not an analyst, and can have access only to business reports, but not to technical reports. Only NCB analysts and NCB end users can have access to reports on Liquidity Transfers, but not CSDs or CSD Participants or External CSD.

Each predefined report and query can be accessible only to a specific restricted list of LTSI privileges.

#### 5.3.5.1 BSIQ.01 - Multi-criteria search of a set of Settlement Instructions - List Screen

△

| Privileges   |
|--------------|
| NCB analyst  |
| NCB end user |

| Privileges               |
|--------------------------|
| CSD analyst              |
| CSD end user             |
| CSD participant end user |
| External CSD end user    |

### 5.3.5.2 BSIQ.00 - Individual Settlement detailed Query – List Screen

△

| Privileges               |
|--------------------------|
| NCB analyst              |
| CSD analyst              |
| NCB end user             |
| CSD end user             |
| CSD participant end user |
| External CSD end user    |

### 5.3.5.3 BSIQ.00 - Individual Settlement detailed Query – Search Screen

△

| Privileges               |
|--------------------------|
| NCB analyst              |
| CSD analyst              |
| NCB end user             |
| CSD end user             |
| CSD participant end user |
| External CSD end user    |

### 5.3.5.4 BSIQ.01 - Multi-criteria search of a set of Settlement Instructions - Search Screen

△

| Privileges  |
|-------------|
| NCB analyst |

| Privileges               |
|--------------------------|
| NCB end user             |
| CSD analyst              |
| CSD end user             |
| CSD participant end user |
| External CSD end user    |

### 5.3.5.5 BSIQ.02 - Individual Restriction detailed Query – List Screen

△

| Privileges               |
|--------------------------|
| NCB analyst              |
| CSD analyst              |
| NCB end user             |
| CSD end user             |
| CSD participant end user |
| External CSD end user    |

### 5.3.5.6 BSIQ.02 - Individual Restriction detailed Query – Search Screen

△

| Privileges               |
|--------------------------|
| NCB analyst              |
| CSD analyst              |
| NCB end user             |
| CSD end user             |
| CSD participant end user |
| External CSD end user    |

### 5.3.5.7 BSIQ.03 - Multi-criteria search of a set of Settlement Restrictions - List Screen

△

| Privileges               |
|--------------------------|
| NCB analyst              |
| NCB end user             |
| CSD analyst              |
| CSD end user             |
| CSD participant end user |
| External CSD end user    |

### 5.3.5.8 BSIQ.03 - Multi-criteria search of a set of Settlement Restrictions - Search Screen

△

| Privileges               |
|--------------------------|
| NCB analyst              |
| NCB end user             |
| CSD analyst              |
| CSD end user             |
| CSD participant end user |
| External CSD end user    |

### 5.3.5.9 BSIQ.04 - Multi-criteria search of a set of Liquidity Transfers - List Screen

△

| Privileges   |
|--------------|
| NCB analyst  |
| NCB end user |

### 5.3.5.10 BSIQ.04 - Multi-criteria search of a set of Liquidity Transfers - Search Screen

△

| Privileges   |
|--------------|
| NCB analyst  |
| NCB end user |

### 5.3.5.11 BSIQ.05 - Multi-criteria search of a set of Business Cancellations - List Screen



| Privileges               |
|--------------------------|
| NCB analyst              |
| NCB end user             |
| CSD analyst              |
| CSD end user             |
| CSD participant end user |
| External CSD end user    |

### 5.3.5.12 BSIQ.05 - Multi-criteria search of a set of Business Cancellations - Search Screen



| Privileges               |
|--------------------------|
| NCB analyst              |
| NCB end user             |
| CSD analyst              |
| CSD end user             |
| CSD participant end user |
| External CSD end user    |

### 5.3.5.13 BSIQ.06 - Multi-criteria search of a set of Amendment Instructions – List Screen



| Privileges               |
|--------------------------|
| NCB analyst              |
| NCB end user             |
| CSD analyst              |
| CSD end user             |
| CSD participant end user |
| External CSD end user    |

### 5.3.5.14 BSIQ.06 - Multi-criteria search of a set of Amendment Instructions - Search Screen



| Privileges               |
|--------------------------|
| NCB analyst              |
| NCB end user             |
| CSD analyst              |
| CSD end user             |
| CSD participant end user |
| External CSD end user    |

### 5.3.5.15 BSIQ.07 - Multi-criteria search of a set of Hold and Release Instructions - List Screen



| Privileges               |
|--------------------------|
| NCB analyst              |
| NCB end user             |
| CSD analyst              |
| CSD end user             |
| CSD participant end user |
| External CSD end user    |

### 5.3.5.16 BSIQ.07 - Multi-criteria search of a set of Hold and Release Instructions - Search Screen



| Privileges               |
|--------------------------|
| NCB analyst              |
| NCB end user             |
| CSD analyst              |
| CSD end user             |
| CSD participant end user |
| External CSD end user    |

### 5.3.5.17 BSIR.00 - T2SDCA: Finalised matched Instructions – List Screen



| Privileges   |
|--------------|
| NCB analyst  |
| NCB end user |

### 5.3.5.18 BSIR.00 - T2SDCA: Finalised matched Instructions – Search Screen



| Privileges   |
|--------------|
| NCB analyst  |
| NCB end user |

### 5.3.5.19 BSIR.01 - Securities Account: Finalised matched Instructions - List Screen



| Privileges               |
|--------------------------|
| CSD analyst              |
| CSD end user             |
| CSD participant end user |
| External CSD end user    |

### 5.3.5.20 BSIR.01 - Securities Account: Finalised matched Instructions - Search Screen



| Privileges               |
|--------------------------|
| CSD analyst              |
| CSD end user             |
| CSD participant end user |
| External CSD end user    |

### 5.3.5.21 BSIR.02 - T2SDCA: Detailed Finalised matched Settlement Instructions - List Screen



| Privileges   |
|--------------|
| NCB analyst  |
| NCB end user |

### 5.3.5.22 BSIR.02 - T2SDCA: Detailed Finalised matched Settlement Instructions - Search Screen



| Privileges   |
|--------------|
| NCB analyst  |
| NCB end user |

### 5.3.5.23 BSIR.03 - Securities Account: Detailed Finalised matched Settlement Instructions - List Screen



| Privileges               |
|--------------------------|
| NCB analyst              |
| NCB end user             |
| CSD analyst              |
| CSD end user             |
| CSD participant end user |
| External CSD end user    |

### 5.3.5.24 BSIR.03 - Securities Account: Detailed Finalised matched Settlement Instructions - Search Screen



| Privileges   |
|--------------|
| NCB analyst  |
| CSD analyst  |
| NCB end user |



| Privileges               |
|--------------------------|
| CSD end user             |
| CSD participant end user |
| External CSD end user    |

### 5.3.5.25 BSIR.04 - T2SDCA: Follow-up by time slot of Settlement Activity - List Screen

△

| Privileges   |
|--------------|
| NCB analyst  |
| NCB end user |

### 5.3.5.26 BSIR.04 - T2SDCA: Follow-up by time slot of Settlement Activity - Search Screen

△

| Privileges   |
|--------------|
| NCB analyst  |
| NCB end user |

### 5.3.5.27 BSIR.05 - T2SDCA: Comparison of Settlement activity between two time periods - List Screen

△

| Privileges   |
|--------------|
| NCB analyst  |
| NCB end user |

### 5.3.5.28 BSIR.05 - T2SDCA: Comparison of Settlement activity between two time periods - Search Screen

△

| Privileges   |
|--------------|
| NCB analyst  |
| NCB end user |

### 5.3.5.29 CMBR.00 - Journaling of Limit Utilisations of Primary CMB - Search Screen

△

| Privileges  |
|-------------|
| NCB analyst |

### 5.3.5.30 CMBR.00 - Journaling of Limits Utilisations of Primary CMB - List Screen

△

| Privileges  |
|-------------|
| NCB analyst |

### 5.3.5.31 CMBR.01 - Journaling of Limits Utilisations of Secondary CMB - List Screen

△

| Privileges  |
|-------------|
| NCB analyst |

### 5.3.5.32 CMBR.01 - Journaling of Limits Utilisations of Secondary CMB - Search Screen

△

| Privileges  |
|-------------|
| NCB analyst |

### 5.3.5.33 COLL.00 - T2SDCA: Follow-up by time slot of Settled Collateralisation Instructions - List Screen

△

| Privileges  |
|-------------|
| NCB analyst |

### 5.3.5.34 COLL.00 - T2SDCA: Follow-up by time slot of Settled Collateralisation Instructions - Search Screen

△

**Privileges**

NCB analyst

**5.3.5.35 COLL.01 - Securities Accounts: Follow up by time slot of Settled Collateralisation Instructions - Search Screen**

△

**Privileges**

CSD analyst

**5.3.5.36 COLL.01 - Securities Accounts: Follow-up by time slot of Settled Collateralisation Instructions - List Screen**

△

**Privileges**

CSD analyst

**5.3.5.37 COLL.02 - T2SDCA: Settled or Cancelled (automatic or manual) Collateralisation Instructions - List Screen**

△

**Privileges**

NCB analyst

**5.3.5.38 COLL.02 - T2SDCA: Settled or Cancelled (automatic or manual) Collateralisation Instructions - Search Screen**

△

**Privileges**

NCB analyst

**5.3.5.39 CPST.00 - T2SDCA: Follow-up by time slot of Cash Postings - List Screen**

△

| Privileges   |
|--------------|
| NCB analyst  |
| NCB end user |

#### 5.3.5.40 CPST.00 - T2SDCA: Follow-up by time slot of Cash Postings - Search Screen

△

| Privileges   |
|--------------|
| NCB analyst  |
| NCB end user |

#### 5.3.5.41 LIQU.00 - Liquidity Transfers - List Screen

△

| Privileges   |
|--------------|
| NCB analyst  |
| NCB end user |

#### 5.3.5.42 LIQU.00 - Liquidity Transfers - Search Screen

△

| Privileges   |
|--------------|
| NCB analyst  |
| NCB end user |

#### 5.3.5.43 REAL.00 - Detailed Realignment and Other Technical Instructions - List Screen

△

| Privileges  |
|-------------|
| CSD analyst |

#### 5.3.5.44 REAL.00 - Detailed Realignment and Other Technical Instructions - Search Screen

△

| Privileges  |
|-------------|
| CSD analyst |

### 5.3.5.45 REST.00 - Detailed Cash Restrictions - List Screen



| Privileges   |
|--------------|
| NCB analyst  |
| NCB end user |

### 5.3.5.46 REST.00 - Detailed Cash Restrictions - Search Screen



| Privileges   |
|--------------|
| NCB analyst  |
| NCB end user |

### 5.3.5.47 REST.01 - Detailed Securities Restrictions - Search Screen



| Privileges               |
|--------------------------|
| CSD analyst              |
| CSD end user             |
| CSD Participant end user |
| External CSD end user    |

### 5.3.5.48 REST.01 - Detailed Securities Restrictions - List Screen



| Privileges               |
|--------------------------|
| CSD analyst              |
| CSD end user             |
| CSD Participant end user |

SPST.00 - Securities Account: Follow-up by time schedule of Securities Postings - List Screen

| Privileges            |
|-----------------------|
| External CSD end user |

### 5.3.5.49 SPST.00 - Securities Account: Follow-up by time schedule of Securities Postings - List Screen

△

| Privileges               |
|--------------------------|
| NCB analyst              |
| NCB end user             |
| CSD analyst              |
| CSD end user             |
| CSD participant end user |
| External CSD end user    |

### 5.3.5.50 SPST.00 - Securities Account: Follow-up by time schedule of Securities Postings - Search Screen

△

| Privileges               |
|--------------------------|
| NCB analyst              |
| NCB end user             |
| CSD analyst              |
| CSD end user             |
| CSD participant end user |
| External CSD end user    |

### 5.3.5.51 XREP.00 - T2SDCA: Matched Cancelled Instructions - List Screen

△

| Privileges   |
|--------------|
| NCB analyst  |
| NCB end user |

### 5.3.5.52 XREP.00 - T2SDCA: Matched Cancelled Instructions - Search Screen



| Privileges   |
|--------------|
| NCB analyst  |
| NCB end user |

### 5.3.5.53 XREP.01 - Securities Account: Matched Cancelled Instructions - List Screen



| Privileges               |
|--------------------------|
| NCB analyst              |
| CSD analyst              |
| NCB end user             |
| CSD end user             |
| CSD participant end user |
| External CSD end user    |

### 5.3.5.54 XREP.01 - Securities Account: Matched Cancelled Instructions - Search Screen



| Privileges               |
|--------------------------|
| CSD analyst              |
| CSD end user             |
| CSD Participant end user |
| External CSD end user    |

### 5.3.5.55 XREP.02 - Finalised Non Matched Cancellations - List Screen



| Privileges   |
|--------------|
| CSD analyst  |
| CSD end user |

| Privileges               |
|--------------------------|
| CSD Participant end user |
| External CSD end user    |

### 5.3.5.56 XREP.02 - Finalised Non Matched Cancellations - Search Screen

△

| Privileges               |
|--------------------------|
| CSD analyst              |
| CSD end user             |
| CSD participant end user |
| External CSD end user    |

### 5.3.6 Privileges for DWH Screens

| Privilege Name | Privilege Short Name | Authorised to  |
|----------------|----------------------|--|
| Normal user    | NORU                 | <ul style="list-style-type: none"> <li><input type="checkbox"/> Access to predefined DWH reports</li> <li><input type="checkbox"/> Use available parameters and filter criteria on predefined DWH reports</li> <li><input type="checkbox"/> Execute predefined DWH reports</li> <li><input type="checkbox"/> Execute user-defined reports (only CB users)</li> <li><input type="checkbox"/> Download DWH report results</li> </ul> |
| Advanced user  | ADVU                 | <ul style="list-style-type: none"> <li><input type="checkbox"/> Same as normal user</li> <li><input type="checkbox"/> Create user defined DWH Reports</li> <li><input type="checkbox"/> Configure the scheduling of DWH reports</li> </ul>   |



| Privilege Name | Privilege Short Name | Authorised to   |
|----------------|----------------------|---|
|                |                      | <ul style="list-style-type: none"> <li><input type="checkbox"/> Store adaptable/user defined DWH reports in an individual dedicated folder</li> <li><input type="checkbox"/> Share (user defined) DWH reports with all other users within their CB or with other CBs in a dedicated folder</li> </ul> |

## 5.4 List of References for Error Messages

### 5.4.1 Reader's Guide

**Reader's Guide**

This section includes a list of references for error messages for all screens, structured along GUI screens, TMS screens. For GUI screens, the list of references for error messages consists of a general section, which lists overall error codes that apply to all GUI screens, and a section listing all error codes relevant for using the 4-eyes mode in GUI screens. For all sections, these are followed by specific sections for individual screens, which are organised in alphabetical screen order and specify the respective error codes applicable for each screen. Each error code table entry includes the error text and the description.

### 5.4.2 References for Error Messages for T2S GUI Screens

#### 5.4.2.1 All

| Reference for error message | Field or Button | Error Text   | Description   |
|-----------------------------|-----------------|--|---|
| DXAA007                     |                 | Only one instance may become effective in the future | Each historical entity may have no more than one future instance. |

| Reference for error message | Field or Button | Error Text  | Description  |
|-----------------------------|-----------------|---|--|
| ICAC001                     |                 | Online access to the T2S system is not available                                  | Users accessing T2S in U2A mode must be alerted when U2A access to T2S is unavailable.   |
| <del>ICUR002</del>          |                 | <del>Required Certificate Authentication failed.</del>                            | <del>Authentication in U2A mode is possible by using simple authentication, advanced certificate authentication or smartcard authentication. Strong authentication mechanisms are ensured via two-factor authentication.</del> |
| <del>ICUR003</del>          |                 | <del>Your password has expired. Please change.</del>                              | <del>The password has to be changed as defined in the security requirements.</del>   |
| <del>ICUR004</del>          |                 | <del>Request is only allowed during valid session. Please log in.</del>           | <del>Requests except login request are only possible, if the user is logged in with a valid session.</del>   |
| <del>ICUR005</del>          |                 | <del>The T2S system user is blocked due to lockout</del>                          | <del>The T2S system user should be able to login. Therefore the lockout status has to be 'False'.</del>  |
| <del>ICUR007</del>          |                 | <del>The Party Technical Address is not known for the used Network Service.</del> | <del>The technical sending user (Party Technical Address) has to be known for the used network service.</del>  |

| Reference for error message | Field or Button | Error Text  | Description  |
|-----------------------------|-----------------|---|--|
| <del>ICUR008</del>          |                 |   | <del>Authentication re-mains active for the entire session.</del>  |
| <del>ICUR009</del>          |                 | <del>Password is invalid for T2S.</del>   | <del>The correct password has to be entered while starting a new session.</del>  |
| <del>ICUR010</del>          |                 | <del>The Technical Sending User is not known for T2S.</del>                               | <del>The Technical Sending User (Party Technical Address) which was used for sending the inbound U2A communication has to be known in T2S.</del> |
| <del>ICUR011</del>          |                 | <del>The Business Sending User is not known in T2S.</del>                                 | <del>The Business Sending User has to be known in T2S.</del>   |
| <del>ICUR012</del>          |                 | <del>The T2S System User sending the inbound U2A communication is not known in T2S.</del> | <del>The T2S System User sending the inbound U2A communication has to be known in T2S.</del>   |
| <del>ICUR013</del>          |                 | <del>The Party Technical Address is not known for the Business Sending Party.</del>       | <del>Technical Sending User is allowed to send for the Business Sending Party.</del>   |
| <del>ICUR014</del>          |                 | <del>Business Sending User is not allowed to send for the T2S Internal System User.</del> | <del>Business sending user is allowed to send for the T2S internal system user. {CR-847}</del>   |
| IICF001                     |                 | Your request is rejected because it is not allowed during                                 | The availability of some U2A requests is restricted on the basis of phases of the business day. The request can                                  |

| Reference for error message | Field or Button | Error Text  | Description  |
|-----------------------------|-----------------|---|--|
|                             |                 | this business day phase. Please try again later.  | only be forwarded, if the functionality is currently available (not restricted).   |
| IICP001                     |                 | The system user is not authorised to initiate such request due to missing privilege.  | A system user must have the appropriate privilege to be authorised for an intended request. The check only includes generic authorisation for the requested action at system level. The check for the data scope including object level is processed in the backend modules. |
| IIUR001                     |                 | The request could not be processed due to a failed validation of syntax and structure<br><!--Dynamic error message(s) is/are mentioned including the respective screen attribute--> | A request is compliant to the syntax and structure of requests required by T2S in the U2A mode.  |

#### 5.4.2.2 All Screens which allow the initiation of a query

| Reference for error message | Field or Button | Error Text   | Description   |
|-----------------------------|-----------------|--|---|
| QMPQ001                     |                 | The System User has not the privilege to initiate such a request for the specified object. | A system user must have the appropriate privilege for the specified object to be permitted. |

| Reference for error message | Field or Button | Error Text  | Description   |
|-----------------------------|-----------------|---|---|
|                             |                 |   | ted to query the requested information.   |
| QMPQ002                     |                 | The System User has not the privilege to initiate such a request. | A system user must have the appropriate privilege for at least one object to be permitted to query the requested information. |

#### 5.4.2.3 All Screens which allow the initiation of a second user action (4-eyes mode)

| Reference for error message | Field or Button | Error Text  | Description  |
|-----------------------------|-----------------|---|--|
| DXAA002                     |                 | Data awaiting for approval cannot be modified                           | It is not allowed to perform a maintenance request, neither in 2-eyes nor in 4-eyes first step mode, that refers to an instance already awaiting for approval.                           |
| DXAA011                     |                 | Invalid approval requestor (must be different from the first requestor) | In case of approval request (4-eyes second step), the requestor must be different from the requestor of the first step. It can be equal only in case of revocation (confirmation = 'NO') |
| DXAA035                     |                 | Request to be approved not found  | In case of approval request (4-eyes second step), the request must refer to an existing in-  |

| Reference for error message | Field or Button | Error Text   | Description  |
|-----------------------------|-----------------|--|--|
|                             |                 |  | struction and the related entity(ies) must be in status 'Awaiting approval'.   |
| IICP003                     |                 | The T2S System User is not authorised to confirm the own initial request.                              | The T2S System User has to be different for the initial request (4-eyes first step) and the confirmation (4-eyes second step) initiated via approval request. In case of revocation the T2S System User can be the same. |
| IICP004                     |                 | The initial request is already completed with status approved, queued, rejected or revoked.            | A successful approval request (second user action; confirmation or revocation) is only possible, if the status of the 4-eyes principle entry is different from 'Approved', 'Queued', 'Rejected' or 'Revoked'.            |
| IICP005                     |                 | An approval request (second user action; confirmation or revocation) is already in processing.         | A successful approval request (second user action; confirmation or revocation) is only possible, if there is no approval request in processing.  |
| IICP006                     |                 | The T2S System Users for the initial request and the confirmation have to be linked to the same party. | The T2S System Users for the initial request (4-eyes first step) and the confirmation (4-eyes second step) initiated   |

| Reference for error message | Field or Button | Error Text | Description   |
|-----------------------------|-----------------|------------|---|
|                             |                 |            | via approval request have to be linked to the same party. |

#### 5.4.2.4 Allegement Instruction - Details Screen

△ [▶ 93]

No references for error messages.

#### 5.4.2.5 Allegement Instructions - Search/List Screen

△ [▶ 89]

| Reference for error message | Field or Button  | Error Text                          | Description  |
|-----------------------------|--|-------------------------------------|--|
| QMPC015                     | <input type="checkbox"/> Creation Date and Time from field<br><input type="checkbox"/> Creation Date and Time to field<br><input type="checkbox"/> Search button | The Date From is after the Date To. | In case the Date is stated as a range, the Date From has to be before or equal to the Date To. |

#### 5.4.2.6 Amendment Cash Instruction - Details Screen

△ [▶ 404]

No references for error messages.

#### 5.4.2.7 Amendment Cash Instruction - New Screen

△ [▶ 409]

| Reference for error message | Field or Button                        | Error Text  | Description   |
|-----------------------------|--|---|---|
| MMIA002                     | <input type="checkbox"/> Submit button | Settlement Restriction referenced by an Amendment Instruction is already settled. | The Settlement Status of a Settlement Restriction referenced by an Amendment Instruction must not be 'Settled'. |

| Reference for error message | Field or Button  | Error Text  | Description   |
|-----------------------------|--|---|---|
| MMIA004                     | <input type="checkbox"/> Submit button   | Settlement Restriction referenced by an Amendment Instruction is already partially settled.   | The Settlement Status of a Settlement Restriction referenced by an Amendment Instruction must not be 'Partially Settled' if the modification is not referred to Priority.   |
| MMIA006                     | <input type="checkbox"/> Submit button   | Settlement Restriction referenced by an Amendment Instruction is already cancelled.   | The Cancellation Status of a Settlement Restriction referenced by an Amendment Instruction must not be 'Cancelled'.   |
| MVCM956                     | <input type="checkbox"/> Submit Button   | The Condition Modification Instruction referring to a Settlement Restriction contains a pool reference or more than one link referring to the same instruction.         | A Condition Modification Instruction that tries to amend a Settlement Restriction must not contain a pool reference or more than one link referring to the same instruction.  |
| MVCM958                     | <input type="checkbox"/> Actor Reference field<br><input type="checkbox"/> Link/Unlink field<br><input type="checkbox"/> T2S Reference field<br><input type="checkbox"/> Submit button | The linkage specified in the Condition Modification Instruction does not exist for the referenced Settlement Restriction or it is pending to be executed in the system. | When a Condition Modification Instruction tries to amend the linkages of a Settlement Restriction with an unlink type, the corresponding link must exist for the referenced Settlement Restriction and it must not be already pending to be executed in the system. |



| Reference for error message | Field or Button  | Error Text   | Description   |
|-----------------------------|--|--|---|
| MVCM960                     | <input type="checkbox"/> Link/Unlink field<br><input type="checkbox"/> Reference field<br><input type="checkbox"/> Submit button         | The linkage specified in the Condition Modification Instruction does not exist for the referenced Settlement Restriction or the amendment is already pending to be executed in the system. | When a Condition Modification Instruction tries to amend the linkages of a Settlement Restriction with a LINK linkage type, the corresponding link regardless its processing position, must not exist for the referenced Settlement Restriction and it must not be already pending to be executed in the system. Only creation of new links are possible. |
| MVCP004                     | <input type="checkbox"/> Actor Reference field<br><input type="checkbox"/> T2S Reference field<br><input type="checkbox"/> Submit Button | The underlying instruction referenced by a Condition Modification Instruction does not exist in T2S.   | The underlying instruction of a Condition Modification instruction must exist in T2S.   |
| MVCP034                     | <input type="checkbox"/> Amendment Type field  | The sender of an Amendment Instruction is not authorised to amend Process Indicators of a Settlement Restriction on Cash on the T2S Dedicated Cash Account.                                | The sender of an Amendment Instruction that intends to amend Process Indicators of a Settlement Restriction on Cash must be authorised to amend Process Indicators of a Settlement Restriction on Cash on a specific T2S Dedicated Cash Account.  |
| MVCP042                     | <input type="checkbox"/> Link Type field<br><input type="checkbox"/> Submit button   | The sender of a Condition Modification Instruction is not authorised to  | The sender of a Condition Modification Instruction that intends to link a Settlement Re-  |

| Reference for error message | Field or Button   | Error Text  | Description  |
|-----------------------------|---|---|--|
|                             |   | link a Settlement Restriction on Cash to an instruction/pool belonging to another party.  | striction on Cash to another instruction or pool must be authorised to link to an instruction/pool belonging to a specific party.  |
| MVCP099                     | <input type="checkbox"/> Reference Type field<br><input type="checkbox"/> Reference field<br><input type="checkbox"/> Submit button                           | The Reference Owner of the Linked Instruction does not belong to the CSD (parent CSD in case of an external CSD) or NCB of the Instructing Party. | If a T2S actor wants to make use of linkages across several instructions sent to T2S via different CSDs or NCBs he holds accounts with, the T2S actor has to make use of the T2S reference.                      |
| MVCP122                     | <input type="checkbox"/> Instructing Party BIC field<br><input type="checkbox"/> Instructing Party Parent BIC field<br><input type="checkbox"/> Submit button | The sender of an Amendment Instruction is not authorised to send an Amendment Instruction using this Instructing Party.                           | If the sender of an Amendment Instruction does not belong to the Instructing Party, then the sender of an Amendment Instruction must be authorised to send an Amendment Instruction using the Instructing Party. |
| MVCV107                     | <input type="checkbox"/> Instructing Party BIC field<br><input type="checkbox"/> Instructing Party Parent BIC field<br><input type="checkbox"/> Submit button | The Instructing Party specified in the Amendment Instruction is not open on the current business date.  | The Instructing Party specified in an Amendment Instruction must be open on the current business date.   |
| MVCV232                     | <input type="checkbox"/> Instructing Party BIC field<br><input type="checkbox"/> Instructing Party Parent BIC field<br><input type="checkbox"/> Submit button | The Instructing Party BIC or Parent BIC specified in the Amendment  | The Instructing Party BIC and Parent BIC indicated in an Amendment Instruction must be valid on the current business date.   |

| Reference for error message | Field or Button   | Error Text  | Description   |
|-----------------------------|---|---|---|
|                             |   | Instruction is not valid on the current business date.  |   |
| MVDC026                     | <input type="checkbox"/> Instructing Party BIC field<br><input type="checkbox"/> Instructing Party Parent BIC field<br><input type="checkbox"/> Submit button | The Instructing Party specified in the Condition Modification Instruction does not exist in T2S Static Data.                | The Instructing Party specified in a Condition Modification Instruction must exist in T2S Static Data.  |
| MVLI809                     | <input type="checkbox"/> Link Type field<br><input type="checkbox"/> Submit button  | The instruction has a Settlement link indicator 'WITH' and the existing Linked Instruction is already settled.              | If an Amendment Instruction tries to add a link 'WITH' to a Settlement Instruction or Settlement Restriction the linked Settlement Instruction or Settlement Restriction must not be 'Settled'.   |
| MVLI810                     | <input type="checkbox"/> Link Type field<br><input type="checkbox"/> Submit button  | The instruction has a Settlement link indicator 'WITH' and the existing Linked Instruction is already cancelled.            | If an Amendment Instruction tries to add a link 'WITH' to a Settlement Instruction or Settlement Restriction the linked Settlement Instruction or Settlement Restriction must not be 'Cancelled'. |
| MVLI811                     | <input type="checkbox"/> Link Type field<br><input type="checkbox"/> Submit button  | The instruction has a Settlement link indicator 'BEFORE' and the existing linked Settlement instruction is already settled. | If an Amendment Instruction tries to add a link 'BEFORE' to a Settlement Instruction or Settlement Restriction the linked Settlement Instruction or Settlement Restriction must not be 'Settled'. |

| Reference for error message | Field or Button  | Error Text  | Description   |
|-----------------------------|--|---|---|
| MVLI825                     | <ul style="list-style-type: none"> <li><input type="checkbox"/> Link Type field</li> <li><input type="checkbox"/> Submit button</li> </ul> | The instruction has a Settlement link indicator 'BEFORE' and the Settlement link indicator included in the existing linked instruction is 'WITH'. | If an Amendment Instruction intends to add a new link 'BEFORE' to a Settlement Instruction or Settlement Restriction, these latter must not have a previous link 'WITH' with the Settlement Instruction stated in the amendment (as linked instruction) unless they have the same Intended Settlement Date. |
| MVLI826                     | <ul style="list-style-type: none"> <li><input type="checkbox"/> Link Type field</li> <li><input type="checkbox"/> Submit button</li> </ul> | The instruction has a Settlement link indicator 'AFTER' and the Settlement link indicator included in the existing linked instruction is 'WITH'.  | If an Amendment Instruction intends to add a new link 'AFTER' to a Settlement Instruction or Settlement Restriction, these latter must not have a previous link 'WITH' with the Settlement Instruction stated in the amendment (as linked instruction) unless they have the same Intended Settlement Date.  |
| MVLI827                     | <ul style="list-style-type: none"> <li><input type="checkbox"/> Link Type field</li> <li><input type="checkbox"/> Submit button</li> </ul> | The instruction has a Settlement link indicator 'AFTER' and the Settlement link indicator included in the existing linked instruction is 'AFTER'. | If an Amendment Instruction intends to add a new link 'AFTER' to a Settlement Instruction or Settlement Restriction, these latter must not have a previous link 'AFTER' with the Settlement Instruction stated in the amendment (as   |

| Reference for error message | Field or Button  | Error Text  | Description   |
|-----------------------------|--|---|---|
|                             |  |   | linked instruction) unless they have the same Intended Settlement Date.   |
| MVLI828                     | <ul style="list-style-type: none"> <li><input type="checkbox"/> Link Type field</li> <li><input type="checkbox"/> Submit button</li> </ul> | The instruction has a Settlement link indicator 'WITH' and the Settlement link indicator included in the existing linked instruction is 'AFTER'.    | If an Amendment Instruction intends to add a new link 'WITH' to a Settlement Instruction or Settlement Restriction, these latter must not have a previous link 'AFTER' with the Settlement Instruction stated in the amendment (as linked instruction) unless they have the same Intended Settlement Date.    |
| MVLI829                     | <ul style="list-style-type: none"> <li><input type="checkbox"/> Link Type field</li> <li><input type="checkbox"/> Submit button</li> </ul> | The instruction has a Settlement link indicator 'BEFORE' and the Settlement link indicator included in the existing linked instruction is 'BEFORE'. | If an Amendment Instruction intends to add a new link 'BEFORE' to a Settlement Instruction or Settlement Restriction, these latter must not have a previous link 'BEFORE' with the Settlement Instruction stated in the amendment (as linked instruction) unless they have the same Intended Settlement Date. |
| MVLI830                     | <ul style="list-style-type: none"> <li><input type="checkbox"/> Link Type field</li> <li><input type="checkbox"/> Submit button</li> </ul> | The instruction has a Settlement link indicator 'WITH' and the Settlement link indicator in-  | If an Amendment Instruction intends to add a new link 'WITH' to a Settlement Instruction or Settlement Restriction, these latter must   |

| Reference for error message | Field or Button  | Error Text  | Description   |
|-----------------------------|--|---|---|
|                             |  | cluded in the existing linked instruction is 'BEFORE'.  | not have a previous link 'BEFORE' with the Settlement Instruction stated in the amendment (as linked instruction) unless they have the same Intended Settlement Date.   |
| MVLI837                     | <input type="checkbox"/> Link Type field<br><input type="checkbox"/> Submit button | The instruction has a Settlement link indicator 'BEFORE' and the linked instruction's Intended Settlement Date is earlier than the validating instruction's Intended Settlement Date. | If an Amendment Instruction tries to add a link 'BEFORE' to a Settlement Instruction or Settlement Restriction, the Intended Settlement Date of the referenced Settlement Instruction or Settlement Restriction must be equal to or earlier than the Intended Settlement Date of the linked Settlement Instruction or Settlement Restriction, if this latter instruction is in T2S. |
| MVLI838                     | <input type="checkbox"/> Link Type field<br><input type="checkbox"/> Submit button | The instruction has a Settlement link indicator 'AFTER' and the linked instruction's Intended Settlement Date is later than the validating instruction's Intended Settlement Date.    | If an Amendment Instruction tries to add a link 'AFTER' to a Settlement Instruction or Settlement Restriction, the Intended Settlement Date of the referenced Settlement Instruction or Settlement Restriction must be equal to or later than the Intended Settlement Date of the linked Settlement In-   |

| Reference for error message | Field or Button  | Error Text   | Description   |
|-----------------------------|--|--|---|
|                             |  |  | struction or Settlement Restriction, if this latter instruction is in T2S.  |
| MVLI839                     | <ul style="list-style-type: none"> <li><input type="checkbox"/> Link Type field</li> <li><input type="checkbox"/> Submit button</li> </ul>   | The instruction has a Settlement link indicator 'WITH' and the linked instruction's Intended Settlement Date is different. | If an Amendment Instruction tries to add a link 'WITH' to a Settlement Instruction or Settlement Restriction, the Intended Settlement Date of the referenced Settlement Instruction or Settlement Restriction must be equal to the Intended Settlement Date of the linked Settlement Instruction or Settlement Restriction, if this latter instruction is in T2S. |
| MVLI852                     | <ul style="list-style-type: none"> <li><input type="checkbox"/> Link Type field</li> <li><input type="checkbox"/> Reference field</li> <li><input type="checkbox"/> Submit button</li> </ul> | The instruction has a Settlement link indicator 'WITH' and the existing Linked Instruction is already partially settled.   | The Settlement Status of a Settlement Instruction or Settlement Restriction stated as linked instruction with Link Processing Position 'WITH' in a Settlement Restriction must not be 'Partially Settled'.  |
| MVLI855                     | <ul style="list-style-type: none"> <li><input type="checkbox"/> Link Type field</li> <li><input type="checkbox"/> Reference field</li> <li><input type="checkbox"/> Submit button</li> </ul> | The instruction has a Settlement link indicator 'BEFORE' and the existing Linked Instruction is already partially settled. | The Settlement Status of a Settlement Instruction or Settlement Restriction stated as linked instruction with Link Processing Position 'BEFORE' in a Settlement Restriction must not be 'Partially Settled'.  |

| Reference for error message | Field or Button  | Error Text  | Description   |
|-----------------------------|--|---|---|
| MVLI858                     | <input type="checkbox"/> Link Type field<br><input type="checkbox"/> Reference field<br><input type="checkbox"/> Submit button   | The instruction has a Settlement link indicator 'AFTER' and the existing Linked Instruction is already partially settled. | The Settlement Status of a Settlement Instruction or Settlement Restriction stated as linked instruction with Link Processing Position 'AFTER' in a Settlement Restriction must not be 'Partially Settled'.                   |
| MVLI861                     | <input type="checkbox"/> Link Type field<br><input type="checkbox"/> Reference field<br><input type="checkbox"/> Submit button   | The instruction has a Settlement link indicator 'AFTER' and the existing Linked Instruction is already cancelled.         | The Settlement Status of a Settlement Instruction or Settlement Restriction stated as linked instruction with Link Processing Position 'AFTER' in a Settlement Restriction must not be 'Cancelled'.                           |
| MVLI871                     | <input type="checkbox"/> Link/Unlink field<br><input type="checkbox"/> Reference field<br><input type="checkbox"/> Submit button | The linked instruction referenced by a T2S Instruction Reference in the Amendment Instruction, does not exist in T2S.     | If an Amendment Instruction intends to modify an instruction link, and the instruction is referenced by the T2S Instruction Reference, then the instruction must exist in T2S.  |
| MVLI874                     | <input type="checkbox"/> Link Type field<br><input type="checkbox"/> Reference field<br><input type="checkbox"/> Submit button   | The Processing Position must be specified in the Amendment Instruction.   | If an Amendment Instruction intends to modify an instruction link, and the instruction is referenced by the T2S Instruction Reference or the T2S Actor Instruction Reference, then the Processing Position must be filled in. |



| Reference for error message | Field or Button   | Error Text  | Description  |
|-----------------------------|---|---|--|
| MVSP211                     | <input type="checkbox"/> Priority field<br><input type="checkbox"/> Submit button | 'Reserved priority' not allowed for the Instructing Party Type (only NCBs can use it) | 'Reserved priority' is allowed in an Amendment Instruction on Settlement Restriction on Cash only if the Instructing Party of the referenced instruction is a NCB. |

#### 5.4.2.8 Amendment Securities Instruction - Details Screen

△ [▶ 97]

No references for error messages.

#### 5.4.2.9 Amendment Securities Instruction - New Screen

△ [▶ 102]

| Reference for error message | Field or Button   | Error Text  | Description   |
|-----------------------------|---|---|---|
| MMIA001                     | <input type="checkbox"/> Submit button  | Settlement Instruction referenced by an Amendment Instruction is already settled.           | The Settlement Status of a Settlement Instruction referenced by an Amendment Instruction must not be 'Settled'. |
| MMIA002                     | <input type="checkbox"/> Submit button  | Settlement Restriction referenced by an Amendment Instruction is already settled.           | The Settlement Status of a Settlement Restriction referenced by an Amendment Instruction must not be 'Settled'. |
| MMIA003                     | <input type="checkbox"/> Amendment Type field<br><input type="checkbox"/> Submit button | Settlement Instruction referenced by an Amendment Instruction is already partially settled. | The Settlement Status of a Settlement Instruction referenced by an Amendment Instruction must not be 'Partially |

| Reference for error message | Field or Button   | Error Text  | Description  |
|-----------------------------|---|---|--|
|                             |   |   | Settled' if the modification is not referred to Priority.  |
| MMIA004                     | <input type="checkbox"/> Amendment Type field<br><input type="checkbox"/> Submit button | Settlement Restriction referenced by an Amendment Instruction is already partially settled. | The Settlement Status of a Settlement Restriction referenced by an Amendment Instruction must not be 'Partially Settled' if the modification is not referred to Priority.  |
| MMIA005                     | <input type="checkbox"/> Submit button  | Settlement Instruction referenced by an Amendment Instruction is already cancelled.         | The Cancellation Status of a Settlement Instruction referenced by an Amendment Instruction must not be 'Cancelled'.  |
| MMIA006                     | <input type="checkbox"/> Submit button  | Settlement Restriction referenced by an Amendment Instruction is already cancelled.         | The Cancellation Status of a Settlement Restriction referenced by an Amendment Instruction must not be 'Cancelled'.  |
| MMIA009                     | <input type="checkbox"/> Submit button  | Settlement Instruction referenced by an Amendment Instruction is in a CoSD Group.           | The CoSD Flag of a Settlement Instruction referenced by an Amendment Instruction must not be 'Yes', except when the Instructing Party is a CSD and the Amendment Instruction aims to remove the linkage from a settlement instruction. |
| MVCM952                     | <input type="checkbox"/> Amendment Type field<br><input type="checkbox"/> Submit button | The Condition Modification Instruction does not refer to the modifi-                        | A Condition Modification Instruction that tries to amend a Settlement Restriction on Secur-  |

| Reference for error message | Field or Button  | Error Text  | Description   |
|-----------------------------|--|---|---|
|                             |  | able process indicators of a Settlement Restriction.  | ies must modify only the settlement priority or the linkages  |
| MVCM955                     | <input type="checkbox"/> Submit button   | The Condition Modification Instruction referring to a Settlement Instruction contains a pool reference or more than one link referring to the same instruction.         | A Condition Modification Instruction that tries to amend a Settlement Instruction must not contain a pool reference or more than one link referring to the same instruction.  |
| MVCM956                     | <input type="checkbox"/> Submit button   | The Condition Modification Instruction referring to a Settlement Restriction contains a pool reference or more than one link referring to the same instruction.         | A Condition Modification Instruction that tries to amend a Settlement Restriction must not contain a pool reference or more than one link referring to the same instruction.  |
| MVCM957                     | <input type="checkbox"/> Actor Reference field<br><input type="checkbox"/> T2S Reference field<br><input type="checkbox"/> Link/Unlink field<br><input type="checkbox"/> Submit button | The linkage specified in the Condition Modification Instruction does not exist for the referenced Settlement Instruction or it is pending to be executed in the system. | When a Condition Modification Instruction tries to amend the linkages of a Settlement Instruction with an unlink type, the corresponding link must exist for the referenced Settlement Instruction and it must not be already pending to be executed in the system. |
| MVCM958                     | <input type="checkbox"/> Actor Reference field   | The linkage specified in the Condition Modification   | When a Condition Modification Instruction tries to amend the link-  |

| Reference for error message | Field or Button  | Error Text   | Description   |
|-----------------------------|--|--|---|
|                             | <ul style="list-style-type: none"> <li><input type="checkbox"/> T2S Reference field</li> <li><input type="checkbox"/> Link/Unlink field</li> <li><input type="checkbox"/> Submit button</li> </ul>   | Instruction does not exist for the referenced Settlement Restriction or it is pending to be executed in the system.  | ages of a Settlement Restriction with an unlink type, the corresponding link must exist for the referenced Settlement Restriction and it must not be already pending to be executed in the system.  |
| MVCM959                     | <ul style="list-style-type: none"> <li><input type="checkbox"/> Actor Reference field</li> <li><input type="checkbox"/> T2S Reference field</li> <li><input type="checkbox"/> Link/Unlink field</li> <li><input type="checkbox"/> Submit button</li> </ul> | The linkage specified in the Condition Modification Instruction exists for the referenced Settlement Instruction or the amendment is already pending to be executed in the system. | When a Condition Modification Instruction tries to amend the linkages of a Settlement Instruction with a LINK linkage type, the corresponding link regardless its processing position, must not exist for the referenced Settlement Instruction and it must not be already pending to be executed in the system. Only creation of new links are possible. |
| MVCM960                     | <ul style="list-style-type: none"> <li><input type="checkbox"/> Actor Reference field</li> <li><input type="checkbox"/> T2S Reference field</li> <li><input type="checkbox"/> Link/Unlink field</li> <li><input type="checkbox"/> Submit button</li> </ul> | The linkage specified in the Condition Modification Instruction exists for the referenced Settlement Restriction or the amendment is already pending to be executed in the system. | When a Condition Modification Instruction tries to amend the linkages of a Settlement Restriction with a LINK linkage type, the corresponding link regardless its processing position, must not exist for the referenced Settlement Restriction and it must not be already pending to be executed in the  |

| Reference for error message | Field or Button  | Error Text  | Description   |
|-----------------------------|--|---|---|
|                             |  |   | system. Only creation of new links are possible.  |
| MVCP004                     | <ul style="list-style-type: none"> <li><input type="checkbox"/> Actor Reference field</li> <li><input type="checkbox"/> T2S Reference field</li> <li><input type="checkbox"/> Submit button</li> </ul> | The underlying instruction referenced by a Condition Modification Instruction does not exist in T2S.  | The underlying instruction of a Condition Modification instruction must exist in T2S.   |
| MVCP027                     | <ul style="list-style-type: none"> <li><input type="checkbox"/> Securities Account Number field</li> <li><input type="checkbox"/> Submit button</li> </ul>   | The sender of the Amendment Instruction is not authorised to amend Process Indicators of a Settlement Instruction on the Securities Account.    | The sender of an Amendment Instruction that intends to amend Process Indicators of a Settlement Instruction must be authorised to amend Process Indicators of a Settlement Instruction on a specific Securities Account.  |
| MVCP028                     | <ul style="list-style-type: none"> <li><input type="checkbox"/> Submit button</li> </ul>   | The sender of the Amendment Instruction is not authorised to amend Process Indicators of a Settlement Instruction on behalf of an external CSD. | If the relevant Depository is an external CSD, the sender of an Amendment Instruction that intends to amend Process Indicators of a Settlement Instruction must be authorised to amend Process Indicators of a Settlement Instruction on behalf of that external CSD. |
| MVCP032                     | <ul style="list-style-type: none"> <li><input type="checkbox"/> Securities Account Number field</li> <li><input type="checkbox"/> Submit button</li> </ul>   | The sender of the Amendment Instruction is not authorised to amend Process Indicators of a Settlement   | The sender of an Amendment Instruction that intends to amend Process Indicators of a Settlement Restriction on Securities must be   |

| Reference for error message | Field or Button  | Error Text   | Description   |
|-----------------------------|--|--|---|
|                             |  | Restriction on Securities on the Securities Account.   | authorised to amend Process Indicators of a Settlement Restriction on Securities on a specific Securities Account.  |
| MVCP039                     | <input type="checkbox"/> Submit button   | The sender of a Condition Modification Instruction is not authorised to amend non-modifiable Instructions on behalf of the Instructing party of the Underlying Settlement Instruction. | The sender of a Condition Modification Instruction that intends to amend a Settlement Instruction identified as a non-modifiable instruction must be authorised to amend non-modifiable Instructions on behalf of the Instructing party of the Underlying Settlement Instruction. |
| MVCP040                     | <input type="checkbox"/> Link Type field<br><input type="checkbox"/> Submit button | The sender of a Condition Modification Instruction is not authorised to link a Settlement Instruction to an instruction/pool belonging to another party.                               | The sender of a Condition Modification Instruction that intends to link a Settlement Instruction to another instruction or pool must be authorised to link to an instruction/pool belonging to a specific party.  |
| MVCP041                     | <input type="checkbox"/> Link Type field<br><input type="checkbox"/> Submit button | The sender of a Condition Modification Instruction is not authorised to link a Settlement Restriction on Securities to an instruction/pool belonging to another party.                 | The sender of a Condition Modification Instruction that intends to link a Settlement Restriction on Securities to another instruction or pool must be authorised to link to an instruction/pool belonging to a specific party.  |

| Reference for error message | Field or Button   | Error Text   | Description  |
|-----------------------------|---|--|--|
| MVCP044                     | <input type="checkbox"/> Securities Account Number field<br><input type="checkbox"/> Submit button                                  | The Securities Account informed in the instruction does not exist in T2S.  | The Securities Account informed in the instruction must exist in T2S.  |
| MVCP095                     | <input type="checkbox"/> Submit button  | The sender of an Amendment Instruction is not authorised to amend Process Indicators of a Settlement Instruction on behalf of the parent CSD of the external CSD.                    | If the relevant Depository is an external CSD, the sender of an Amendment Instruction that intends to amend Process Indicators of a Settlement Instruction must be authorised to amend Process Indicators of a Settlement Instruction on behalf of the parent CSD of the external CSD. |
| MVCP099                     | <input type="checkbox"/> Reference Type field<br><input type="checkbox"/> Reference field<br><input type="checkbox"/> Submit button | The Reference Owner of the Linked Instruction does not belong to the CSD (parent CSD in case of an external CSD) or NCB of the Instructing Party.                                    | If a T2S actor wants to make use of linkages across several instructions sent to T2S via different CSDs or NCBs he holds accounts with, the T2S actor has to make use of the T2S reference.  |
| MVCP108                     | <input type="checkbox"/> Amendment Counterpart Instruction field<br><input type="checkbox"/> Submit button                          | The sender of an Amendment Instruction is not authorised to amend a Settlement Instruction on behalf of the external CSD of the counterparty or the parent CSD of that external CSD. | If the Depository of the counterpart is an external CSD, the sender of an Amendment Instruction that intends to amend both legs of an already matched Settlement Instruction must be authorised to amend a Settlement Instruction on behalf of that ex-                                |

| Reference for error message | Field or Button   | Error Text  | Description  |
|-----------------------------|---|---|--|
|                             |   |   | ternal CSD or the parent CSD of of that external CSD.  |
| MVCP109                     | <input type="checkbox"/> Amendment Counterpart Instruction field<br><input type="checkbox"/> Submit button  | The sender of an Amendment Instruction is not authorised to amend a Settlement Instruction on the Securities Account of the counterparty. | The sender of an Amendment Instruction that intends to amend both legs of an already matched Settlement Instruction must be authorised to amend a Settlement Instruction on the Securities Account of the counterparty (in case the Amendment Instruction only informs one Securities Account, the other would be derived from the underlying Settlement Instruction). |
| MVCP122                     | <input type="checkbox"/> Instructing Party Parent BIC field<br><input type="checkbox"/> Instructing Party BIC field<br><input type="checkbox"/> Submit button | The sender of an Amendment Instruction is not authorised to send an Amendment Instruction using this Instructing Party.                   | If the sender of an Amendment Instruction does not belong to the Instructing Party, then the sender of an Amendment Instruction must be authorised to send an Amendment Instruction using the Instructing Party.   |
| MVCV107                     | <input type="checkbox"/> Instructing Party Parent BIC field<br><input type="checkbox"/> Instructing Party BIC field<br><input type="checkbox"/> Submit button | The Instructing Party specified in the Amendment Instruction is not open on the current business date.                                    | The Instructing Party specified in an Amendment Instruction must be open on the current business date.   |



| Reference for error message | Field or Button   | Error Text  | Description   |
|-----------------------------|---|---|---|
| MVCV232                     | <input type="checkbox"/> Instructing Party Parent BIC field<br><input type="checkbox"/> Instructing Party BIC field<br><input type="checkbox"/> Submit button | The Instructing Party BIC or Parent BIC specified in the Amendment Instruction is not valid on the current business date. | The Instructing Party BIC and Parent BIC indicated in an Amendment Instruction must be valid on the current business date.  |
| MVDC026                     | <input type="checkbox"/> Instructing Party Parent BIC field<br><input type="checkbox"/> Instructing Party BIC field<br><input type="checkbox"/> Submit button | The Instructing Party specified in the Condition Modification Instruction does not exist in T2S Static Data.              | The Instructing Party specified in a Condition Modification Instruction must exist in T2S Static Data.  |
| MVLI809                     | <input type="checkbox"/> Link Type field<br><input type="checkbox"/> Submit button  | The instruction has a Settlement link indicator 'WITH' and the existing Linked Instruction is already settled.            | If an Amendment Instruction tries to add a link 'WITH' to a Settlement Instruction or Settlement Restriction the linked Settlement Instruction or Settlement Restriction must not be 'Settled'.   |
| MVLI810                     | <input type="checkbox"/> Link Type field<br><input type="checkbox"/> Link/Unlink field<br><input type="checkbox"/> Submit button                              | The instruction has a Settlement link indicator 'WITH' and the existing Linked Instruction is already cancelled.          | If an Amendment Instruction tries to add a link 'WITH' to a Settlement Instruction or Settlement Restriction the linked Settlement Instruction or Settlement Restriction must not be 'Cancelled'. |
| MVLI811                     | <input type="checkbox"/> Link Type field<br><input type="checkbox"/> Link/Unlink field<br><input type="checkbox"/> Submit button                              | The instruction has a Settlement link indicator 'BEFORE' and the existing   | If an Amendment Instruction tries to add a link 'BEFORE' to a Settlement Instruction or Settlement Restriction  |

| Reference for error message | Field or Button  | Error Text  | Description   |
|-----------------------------|--|---|---|
|                             |  | isting linked Settlement instruction is already settled.  | the linked Settlement Instruction or Settlement Restriction must not be 'Settled'.  |
| MVLI825                     | <input type="checkbox"/> Link Type field<br><input type="checkbox"/> Link/Unlink field<br><input type="checkbox"/> Submit button | The instruction has a Settlement link indicator 'BEFORE' and the Settlement link indicator included in the existing linked instruction is 'WITH'. | If an Amendment Instruction intends to add a new link 'BEFORE' to a Settlement Instruction or Settlement Restriction, these latter must not have a previous link 'WITH' with the Settlement Instruction stated in the amendment (as linked instruction) unless they have the same Intended Settlement Date. |
| MVLI826                     | <input type="checkbox"/> Link Type field<br><input type="checkbox"/> Link/Unlink field<br><input type="checkbox"/> Submit button | The instruction has a Settlement link indicator 'AFTER' and the Settlement link indicator included in the existing linked instruction is 'WITH'.  | If an Amendment Instruction intends to add a new link 'AFTER' to a Settlement Instruction or Settlement Restriction, these latter must not have a previous link 'WITH' with the Settlement Instruction stated in the amendment (as linked instruction) unless they have the same Intended Settlement Date.  |
| MVLI827                     | <input type="checkbox"/> Link Type field<br><input type="checkbox"/> Link/Unlink field<br><input type="checkbox"/> Submit button | The instruction has a Settlement link indicator 'AFTER' and the Settlement link indicator in-   | If an Amendment Instruction intends to add a new link 'AFTER' to a Settlement Instruction or Settlement Restriction, these latter must  |

| Reference for error message | Field or Button  | Error Text  | Description   |
|-----------------------------|--|---|---|
|                             |  | cluded in the existing linked instruction is 'AFTER'.   | not have a previous link 'AFTER' with the Settlement Instruction stated in the amendment (as linked instruction) unless they have the same Intended Settlement Date.  |
| MVLI828                     | <input type="checkbox"/> Link Type field<br><input type="checkbox"/> Link/Unlink field<br><input type="checkbox"/> Submit button | The instruction has a Settlement link indicator 'WITH' and the Settlement link indicator included in the existing linked instruction is 'AFTER'.    | If an Amendment Instruction intends to add a new link 'WITH' to a Settlement Instruction or Settlement Restriction, these latter must not have a previous link 'AFTER' with the Settlement Instruction stated in the amendment (as linked instruction) unless they have the same Intended Settlement Date.    |
| MVLI829                     | <input type="checkbox"/> Link Type field<br><input type="checkbox"/> Link/Unlink field<br><input type="checkbox"/> Submit button | The instruction has a Settlement link indicator 'BEFORE' and the Settlement link indicator included in the existing linked instruction is 'BEFORE'. | If an Amendment Instruction intends to add a new link 'BEFORE' to a Settlement Instruction or Settlement Restriction, these latter must not have a previous link 'BEFORE' with the Settlement Instruction stated in the amendment (as linked instruction) unless they have the same Intended Settlement Date. |

| Reference for error message | Field or Button  | Error Text  | Description   |
|-----------------------------|--|---|---|
| MVLI830                     | <input type="checkbox"/> Link Type field<br><input type="checkbox"/> Link/Unlink field<br><input type="checkbox"/> Submit button | The instruction has a Settlement link indicator 'WITH' and the Settlement link indicator included in the existing linked instruction is 'BEFORE'.                                     | If an Amendment Instruction intends to add a new link 'WITH' to a Settlement Instruction or Settlement Restriction, these latter must not have a previous link 'BEFORE' with the Settlement Instruction stated in the amendment (as linked instruction) unless they have the same Intended Settlement Date.   |
| MVLI837                     | <input type="checkbox"/> Link Type field<br><input type="checkbox"/> Link/Unlink field<br><input type="checkbox"/> Submit button | The instruction has a Settlement link indicator 'BEFORE' and the linked instruction's Intended Settlement Date is earlier than the validating instruction's Intended Settlement Date. | If an Amendment Instruction tries to add a link 'BEFORE' to a Settlement Instruction or Settlement Restriction, the Intended Settlement Date of the referenced Settlement Instruction or Settlement Restriction must be equal to or earlier than the Intended Settlement Date of the linked Settlement Instruction or Settlement Restriction, if this latter instruction is in T2S. |
| MVLI838                     | <input type="checkbox"/> Link Type field<br><input type="checkbox"/> Link/Unlink field<br><input type="checkbox"/> Submit button | The instruction has a Settlement link indicator 'AFTER' and the linked instruction's Intended Settlement Date is later than   | If an Amendment Instruction tries to add a link 'AFTER' to a Settlement Instruction or Settlement Restriction, the Intended Settlement Date of the referenced   |

| Reference for error message | Field or Button  | Error Text   | Description   |
|-----------------------------|--|--|---|
|                             |  | the validating instruction's Intended Settlement Date.   | Settlement Instruction or Settlement Restriction must be equal to or later than the Intended Settlement Date of the linked Settlement Instruction or Settlement Restriction, if this latter instruction is in T2S.  |
| MVLI839                     | <input type="checkbox"/> Link Type field<br><input type="checkbox"/> Link/Unlink field<br><input type="checkbox"/> Submit button | The instruction has a Settlement link indicator 'WITH' and the linked instruction's Intended Settlement Date is different. | If an Amendment Instruction tries to add a link 'WITH' to a Settlement Instruction or Settlement Restriction, the Intended Settlement Date of the referenced Settlement Instruction or Settlement Restriction must be equal to the Intended Settlement Date of the linked Settlement Instruction or Settlement Restriction, if this latter instruction is in T2S. |
| MVLI853                     | <input type="checkbox"/> Link Type field<br><input type="checkbox"/> Link/Unlink field<br><input type="checkbox"/> Submit button | The instruction has a Settlement link indicator 'WITH' and the existing Linked Instruction is already partially settled.   | If an Amendment Instruction intends to modify a Settlement Instruction or Settlement Restriction link 'WITH', the linked Settlement Instruction or Settlement Restriction must not be Partially Settled.  |
| MVLI856                     | <input type="checkbox"/> Link Type field<br><input type="checkbox"/> Link/Unlink field<br><input type="checkbox"/> Submit button | The instruction has a Settlement link indicator 'BEFORE' and the ex-   | If an Amendment Instruction intends to modify a Settlement Instruction or Settlement  |

| Reference for error message | Field or Button  | Error Text  | Description   |
|-----------------------------|--|---|---|
|                             |  | isting Linked Instruction is already partially settled.   | Restriction link 'BEFORE', the linked Settlement Instruction or Settlement Restriction must no be 'Partially Settled'.  |
| MVLI859                     | <input type="checkbox"/> Link Type field<br><input type="checkbox"/> Link/Unlink field<br><input type="checkbox"/> Submit button | The instruction has a Settlement link indicator 'AFTER' and the existing Linked Instruction is already partially settled. | If an Amendment Instruction intends to modify a Settlement Instruction or Settlement Restriction link 'AFTER', the linked Settlement Instruction or Settlement Restriction must not be 'Partially Settled'. |
| MVLI862                     | <input type="checkbox"/> Link Type field<br><input type="checkbox"/> Link/Unlink field<br><input type="checkbox"/> Submit button | The instruction has a Settlement link indicator 'AFTER' and the existing Linked Instruction is already cancelled.         | If an Amendment Instruction intends to modify a Settlement Instruction link 'AFTER', the linked Settlement Instruction or Settlement Restriction must not be 'Cancelled'.                                   |
| MVLI871                     | <input type="checkbox"/> Link/Unlink field<br><input type="checkbox"/> Reference field<br><input type="checkbox"/> Submit button | The linked instruction referenced by a T2S Instruction Reference in the Amendment Instruction, does not exist in T2S.     | If an Amendment Instruction intends to modify an instruction link, and the instruction is referenced by the T2S Instruction Reference, then the instruction must exist in T2S.                              |
| MVLI874                     | <input type="checkbox"/> Link Type field<br><input type="checkbox"/> Reference field<br><input type="checkbox"/> Submit button   | The Processing Position must be specified in the Amendment Instruction.   | If an Amendment Instruction intends to modify an instruction link, and the instruction is referenced by the   |

| Reference for error message | Field or Button  | Error Text   | Description   |
|-----------------------------|--|--|---|
|                             |  |  | T2S Instruction Reference or the T2S Actor Instruction Reference, then the Processing Position must be filled in.   |
| MVRI555                     | <ul style="list-style-type: none"> <li><input type="checkbox"/> T2S Reference field</li> <li><input type="checkbox"/> Submit button</li> </ul> | The Condition Modification Instruction refers to a T2S generated Settlement Restriction. | A Condition Modification Instruction cannot refer to a T2S generated Settlement Restriction.  |
| MVRI575                     | <ul style="list-style-type: none"> <li><input type="checkbox"/> T2S Reference field</li> <li><input type="checkbox"/> Submit button</li> </ul> | It is not possible to amend a T2S generated Settlement Instruction.                      | A Condition Modification Instruction cannot refer to a T2S generated Realignment Settlement Instruction, unless it is a CoSD Release Instruction and the T2S generated Settlement Instruction has its CoSD Hold Status Set to 'Yes' or it is a CSD Validation release instruction and the T2S generated Settlement Instruction has its CSD Validation Hold Status Set to 'Yes'. |
| MVRI591                     | <ul style="list-style-type: none"> <li><input type="checkbox"/> T2S Reference field</li> <li><input type="checkbox"/> Submit button</li> </ul> | The Condition Modification Instruction refers to a T2S generated Settlement Instruction. | A Condition Modification Instruction cannot refer to a T2S generated Collateral Settlement Instruction, unless it is a Release Instruction and the T2S generated Settlement Instruc-  |

| Reference for error message | Field or Button  | Error Text  | Description  |
|-----------------------------|--|---|--|
|                             |  |   | tion is a Reimbursement Settlement Instruction.  |
| MVSP209                     | <input type="checkbox"/> Instructing Party Parent BIC field<br><input type="checkbox"/> Instructing Party BIC field<br><input type="checkbox"/> Priority field<br><input type="checkbox"/> Submit button | 'Reserved priority' not allowed for the Instructing Party Type (only CSDs can use it) | 'Reserved priority' is allowed in an Amendment Instruction on a Settlement Instruction or Settlement Restriction on Securities only if the Instructing Party of the referenced instruction is a CSD. |

#### 5.4.2.10 Available Report - Current Settlement Day Cash Information (Following Settlement Day Cash Forecast) Report – Details Screen

△ [▶ 458]

No references for error messages.

#### 5.4.2.11 Available Report - Details Screen

△ [▶ 456]

No references for error messages.

#### 5.4.2.12 Available Report - Statement of Accounts - Details Screen

△ [▶ 463]

No references for error messages.

#### 5.4.2.13 Available Report - Statement of Executed Amendment Instructions for Intra-Balance Movements - Details Screen

△ [▶ 466]

No references for error messages.



#### 5.4.2.14 Available Report - Statement of Executed Amendment Instructions for Intra-Position Movements and Settlement Instructions - Details Screen

△ [▶ 471]

No references for error messages.

#### 5.4.2.15 Available Report - Statement of Executed Cancellation Instructions for Intra-Balance Movements - Details Screen

△ [▶ 480]

No references for error messages.

#### 5.4.2.16 Available Report - Statement of Executed Cancellation Instructions for Intra-Position Movements and Settlement Instructions - Details Screen

△ [▶ 484]

No references for error messages.

#### 5.4.2.17 Available Report - Statement of Holdings - Details Screen

△ [▶ 492]

No references for error messages.

#### 5.4.2.18 Available Report - Statement of Pending Amendment Instructions for Intra-Balance Movements - Details Screen

△ [▶ 497]

No references for error messages.

#### 5.4.2.19 Available Report - Statement of Pending Amendment Instructions for Intra-Position Movements and Settlement Instructions - Details Screen

△ [▶ 502]

No references for error messages.

#### 5.4.2.20 Available Report - Statement of Pending Cancellation Instructions for Intra-Balance Movements - Details Screen

△ [▶ 511]

No references for error messages.

#### 5.4.2.21 Available Report - Statement of Pending Cancellation Instructions for Intra-Position Movements and Settlement Instructions - Details Screen

△ [▶ 515]

No references for error messages.

#### 5.4.2.22 Available Report - Statement of Pending Instructions - Details Screen

△ [▶ 523]

No references for error messages.

#### 5.4.2.23 Available Report - Statement of Pending Intra-Balance Movements - Details Screen

△ [▶ 532]

No references for error messages.

#### 5.4.2.24 Available Report - Statement of Pending Intra-Position Movements - Details Screen

△ [▶ 537]

No references for error messages.

#### 5.4.2.25 Available Report - Statement of Settled Intra-Balance Movements - Details Screen

△ [▶ 542]

No references for error messages.

#### 5.4.2.26 Available Report - Statement of Settled Intra-Position Movements - Details Screen

△ [▶ 547]

No references for error messages.

### 5.4.2.27 Available Report - Statement of Settlement Allegements - Details Screen

△ [▶ 550]

No references for error messages.

### 5.4.2.28 Available Report - Statement of Transactions - Details Screen

△ [▶ 563]

No references for error messages.

### 5.4.2.29 Available Reports - Search/List Screen

△ [▶ 451]

| Reference for error message | Field or Button   | Error Text  | Description   |
|-----------------------------|---|---|---|
| QMPC032                     | <input type="checkbox"/> Party BIC field<br><input type="checkbox"/> Search button  | The specified Party BIC is not known in T2S.                              | In case a Party BIC is specified, it has to be known in T2S.  |
| QMPC048                     | <input type="checkbox"/> Parent BIC field<br><input type="checkbox"/> Search button   | The specified Parent BIC is not known in T2S.                             | In case a Parent BIC is specified, it has to be known in T2S.   |
| QMPC055                     | <input type="checkbox"/> Date field<br><input type="checkbox"/> Search button   | The specified business date is in the future.                             | In case a business date is specified, it must not be in the future.   |
| QMPC084                     | <input type="checkbox"/> Parent BIC field<br><input type="checkbox"/> Party BIC field<br><input type="checkbox"/> Search button | The specified Parent BIC is not the System Entity of the specified party. | In case the BIC of a party as well as its parent BIC are specified, a party with these two BICs has to be known in T2S. |

### 5.4.2.30 Broadcast - Details Screen

△ [▶ 619]

No references for error messages.

### 5.4.2.31 Broadcast - New Screen

△ [▶ 621]

No references for error messages.

### 5.4.2.32 Broadcasts - Search/List Screen

△ [▶ 616]

| Reference for error message | Field or Button  | Error Text                          | Description  |
|-----------------------------|--|-------------------------------------|--|
| QMPC015                     | <input type="checkbox"/> Creation Date and Time from field<br><input type="checkbox"/> Creation Date and Time to field<br><input type="checkbox"/> Search button | The Date From is after the Date To. | In case the Date is stated as a range, the Date From has to be before or equal to the Date To. |

### 5.4.2.33 Calendar - Details Screen

△

No references for error messages.

### 5.4.2.34 Cancellation Cash Instruction - Details Screen

△ [▶ 416]

No references for error messages.

### 5.4.2.35 Cancellation Cash Instruction - New Screen

△ [▶ 419]

| Reference for error message | Field or Button   | Error Text   | Description  |
|-----------------------------|---|--|--|
| MVDC027                     | <input type="checkbox"/> Instructing Party Parent BIC field<br><input type="checkbox"/> Instructing Party BIC field<br><input type="checkbox"/> Submit button | The Instructing Party specified in the Cancellation Instruction does not exist in T2S Static Data. | The Instructing Party specified in a Cancellation Instruction must exist in T2S Static Data. |

| Reference for error message | Field or Button   | Error Text   | Description  |
|-----------------------------|---|--|--|
| MVCP123                     | <input type="checkbox"/> Instructing Party Parent BIC field<br><input type="checkbox"/> Instructing Party BIC field<br><input type="checkbox"/> Submit button | The sender of a Cancellation Instruction is not authorised to send a Cancellation Instruction using this Instructing Party.              | If the sender of a Cancellation Instruction does not belong to the Instructing Party, then the sender of a Cancellation Instruction must be authorised to send a Cancellation Instruction using the Instructing Party. |
| MMCR201                     | <input type="checkbox"/> Submit button  | Referenced Settlement Restriction already settled.   | The Settlement Status of a Settlement Restriction referenced by a Cancellation Instruction must not be 'Settled'.  |
| MMCR202                     | <input type="checkbox"/> Submit button  | Referenced Settlement Restriction already cancelled.   | The Cancellation Status of a Settlement Restriction referenced by a Cancellation Instruction must not be 'Cancelled'.  |
| MVCP003                     | <input type="checkbox"/> T2S Reference field<br><input type="checkbox"/> Submit button  | The underlying instruction referenced by a Cancellation Instruction does not exist in T2S.   | The underlying instruction of a Cancellation instruction must exist in T2S.  |
| MVCP035                     | <input type="checkbox"/> Dedicated Cash Account Number field<br><input type="checkbox"/> Submit Button  | The sender of a Cancellation Instruction is not authorised to cancel a Settlement Restriction on Cash on the T2S Dedicated Cash Account. | The sender of a Cancellation Instruction that intends to cancel a Settlement Restriction on Cash must be authorised to cancel a Settlement Restriction on Cash on a specific T2S Dedicated Cash Account.               |

| Reference for error message | Field or Button   | Error Text   | Description  |
|-----------------------------|---|--|--|
| MVCV108                     | <input type="checkbox"/> Instructing Party Parent BIC field<br><input type="checkbox"/> Instructing Party BIC field<br><input type="checkbox"/> Submit button | The Instructing Party specified in the Cancellation Instruction is not open on the current business date.                    | The Instructing Party specified in a Cancellation Instruction must be open on the current business date.                     |
| MVCV231                     | <input type="checkbox"/> Instructing Party Parent BIC field<br><input type="checkbox"/> Instructing Party BIC field<br><input type="checkbox"/> Submit button | The Instructing Party BIC or Parent BIC specified in the Cancellation Instruction is not valid on the current business date. | The Instructing Party BIC and Parent BIC indicated in a Cancellation Instruction must be valid on the current business date. |

### 5.4.2.36 Cancellation Securities Instruction - Details Screen

△ [▶ 112]

No references for error messages.

### 5.4.2.37 Cancellation Securities Instruction - New Screen

△ [▶ 116]

| Reference for error message | Field or Button                        | Error Text   | Description   |
|-----------------------------|--|--|---|
| MMCI101                     | <input type="checkbox"/> Submit button | Referenced Settlement Instruction already settled.   | The Settlement Status of a Settlement Instruction referenced by a Cancellation Instruction must not be 'Settled'.     |
| MMCI102                     | <input type="checkbox"/> Submit button | Referenced Settlement Instruction already cancelled. | The Cancellation Status of a Settlement Instruction referenced by a Cancellation Instruction must not be 'Cancelled'. |

| Reference for error message | Field or Button   | Error Text  | Description  |
|-----------------------------|---|---|--|
| MMCI105                     | <input type="checkbox"/> Submit Button<br><input type="checkbox"/> Instructing Party BIC field<br><input type="checkbox"/> Instructing Party Parent BIC field | Referenced Settlement Instruction on CoSD process.  | If a Settlement Instruction referenced by a Cancellation Instruction is identified as CoSD such Settlement Instruction cannot be cancelled by a Party.                     |
| MMCI106                     | <input type="checkbox"/> Submit Button<br><input type="checkbox"/> Instructing Party BIC field<br><input type="checkbox"/> Instructing Party Parent BIC field | Referenced Settlement Instruction already requested for cancellation by the same Instructing Party. | There is a pending Cancellation Instruction of the same type and Instructing Party (either T2S party, Administering Party or CSD).   |
| MMCI107                     | <input type="checkbox"/> Submit Button<br><input type="checkbox"/> Instructing Party BIC field<br><input type="checkbox"/> Instructing Party Parent BIC field | Referenced Settlement Instruction already requested for cancellation.                               | The Cancellation Request Flag of a Settlement Instruction referenced by an unmatched T2S Party Cancellation Instruction must not be 'Yes'.                                 |
| MMCI108                     | <input type="checkbox"/> Submit Button<br><input type="checkbox"/> Instructing Party BIC field<br><input type="checkbox"/> Instructing Party Parent BIC field | Referenced Settlement Instruction already requested for cancellation.                               | The Cancellation Request Flag of a Settlement Instruction referenced by a CoSD Cancellation Instruction must not be 'Yes'.   |
| MMCI109                     | <input type="checkbox"/> Instructing Party Parent BIC field<br><input type="checkbox"/> Instructing Party BIC field   | Realignment Instruction fulfils a CoSD Rule.  | If a CoSD Rule applies over a Realignment Instruction of the referenced Settlement Instruction such Settlement Instruction can only be cancelled by the corresponding CSD. |

| Reference for error message | Field or Button  | Error Text  | Description   |
|-----------------------------|--|---|---|
| MMCR201                     | <input type="checkbox"/> Submit button   | Referenced Settlement Restriction already settled.  | The Settlement Status of a Settlement Restriction referenced by a Cancellation Instruction must not be 'Settled'.   |
| MMCR202                     | <input type="checkbox"/> Submit button   | Referenced Settlement Restriction already cancelled.  | The Cancellation Status of a Settlement Restriction referenced by a Cancellation Instruction must not be 'Cancelled'.   |
| MVCP003                     | <input type="checkbox"/> Actor Reference field<br><input type="checkbox"/> T2S Reference field<br><input type="checkbox"/> Submit button | The underlying instruction referenced by a Cancellation Instruction does not exist in T2S.                                    | The underlying instruction of a Cancellation instruction must exist in T2S.   |
| MVCP029                     | <input type="checkbox"/> Securities Account field<br><input type="checkbox"/> Submit button  | The sender of the Cancellation Instruction is not authorised to cancel a Settlement Instruction on the Securities Account.    | The sender of a Cancellation Instruction that intends to cancel a Settlement Instruction must be authorised to cancel a Settlement Instruction on a specific Securities Account.  |
| MVCP030                     | <input type="checkbox"/> Submit button   | The sender of the Cancellation Instruction is not authorised to cancel a Settlement Instruction on behalf of an external CSD. | If the relevant Depository is an external CSD, the sender of a Cancellation Instruction that intends to cancel a Settlement Instruction must be authorised to cancel a Settlement Instruction on behalf of that external CSD. |
| MVCP031                     | <input type="checkbox"/> Submit button   | The sender of the Cancellation Instruction is not au-   | The sender of a Cancellation Instruction that intends to cancel a Set-  |



| Reference for error message | Field or Button   | Error Text  | Description   |
|-----------------------------|---|---|---|
|                             |   | thorised to cancel a CoSD Settlement Instruction on behalf of the Administering Party.  | tlement Instruction identified as CoSD must be authorised to cancel a CoSD Settlement Instruction on behalf of the Administering Party identified as the Instructing Party of the cancellation.   |
| MVCP033                     | <input type="checkbox"/> Securities Account field<br><input type="checkbox"/> Submit button | The sender of a Cancellation Instruction is not authorised to cancel a Settlement Restriction on Securities on the Securities Account.  | The sender of a Cancellation Instruction that intends to cancel a Settlement Restriction on Securities must be authorised to cancel a Settlement Restriction on Securities on a specific Securities Account.  |
| MVCP044                     | <input type="checkbox"/> Securities Account field<br><input type="checkbox"/> Submit button | The Securities Account informed in the instruction does not exist in T2S.   | The Securities Account informed in the instruction must exist in T2S.   |
| MVCP048                     | <input type="checkbox"/> Submit button  | The sender of a Cancellation Instruction is not authorised to cancel non-modifiable Instructions on behalf of the Instructing party of the Underlying Settlement Instruction. | The sender of a Cancellation Instruction that intends to cancel a Settlement Instruction identified as a non-modifiable instruction must be authorised to cancel non-modifiable Instructions on behalf of the Instructing party of the Underlying Settlement Instruction. |

| Reference for error message | Field or Button   | Error Text  | Description   |
|-----------------------------|---|---|---|
| MVCP096                     | <input type="checkbox"/> Submit button  | The sender of a Cancellation Instruction is not authorised to cancel a Settlement Instruction on behalf of the parent CSD of the external CSD.  | If the relevant Depository is an external CSD, the sender of a Cancellation Instruction that intends to cancel a Settlement Instruction must be authorised to cancel a Settlement Instruction on behalf of the parent CSD of the external CSD.  |
| MVCP104                     | <input type="checkbox"/> Already Matched Cancellation field<br><input type="checkbox"/> Submit button | The sender of a Cancellation Instruction is not authorised to send a Cancellation Instruction on behalf of the external CSD of the counterparty or the parent CSD of that external CSD. | If the Depository of the counterparty is an external CSD, the sender of a Cancellation Instruction that intends to cancel both legs of an already matched Settlement Instruction must be authorised to cancel a Settlement Instruction on behalf of that external CSD or the parent CSD of that external CSD. |
| MVCP105                     | <input type="checkbox"/> Already Matched Cancellation field<br><input type="checkbox"/> Submit button | The sender of a Cancellation Instruction is not authorised to send a Cancellation Instruction on the Securities Account of the counterparty.  | The sender of a Cancellation Instruction that intends to cancel both legs of an already matched Settlement Instruction must be authorised to cancel a Settlement Instruction on both Securities Accounts (in case the Cancellation Instruction only informs one Securities Account, the other                 |

| Reference for error message | Field or Button   | Error Text   | Description  |
|-----------------------------|---|--|--|
|                             |   |  | would be derived from the underlying Settlement Instruction).  |
| MVCP123                     | <input type="checkbox"/> Instructing Party BIC field<br><input type="checkbox"/> Instructing Party Parent BIC field<br><input type="checkbox"/> Submit button | The sender of a Cancellation Instruction is not authorised to send a Cancellation Instruction using this Instructing Party.  | If the sender of a Cancellation Instruction does not belong to the Instructing Party, then the sender of a Cancellation Instruction must be authorised to send a Cancellation Instruction using the Instructing Party. |
| MVCV108                     | <input type="checkbox"/> Instructing Party BIC field<br><input type="checkbox"/> Instructing Party Parent BIC field<br><input type="checkbox"/> Submit button | The Instructing Party specified in the Cancellation Instruction is not open on the current business date.                    | The Instructing Party specified in a Cancellation Instruction must be open on the current business date.   |
| MVCV231                     | <input type="checkbox"/> Instructing Party BIC field<br><input type="checkbox"/> Instructing Party Parent BIC field<br><input type="checkbox"/> Submit button | The Instructing Party BIC or Parent BIC specified in the Cancellation Instruction is not valid on the current business date. | The Instructing Party BIC and Parent BIC indicated in a Cancellation Instruction must be valid on the current business date.   |
| MVDC027                     | <input type="checkbox"/> Instructing Party BIC field<br><input type="checkbox"/> Instructing Party Parent BIC field<br><input type="checkbox"/> Submit button | The Instructing Party specified in the Cancellation Instruction does not exist in T2S Static Data.                           | The Instructing Party specified in a Cancellation Instruction must exist in T2S Static Data.   |
| MVRI576                     | <input type="checkbox"/> Submit button  | It is not possible to cancel a T2S generated Settlement Instruction.   | A Cancellation Instruction cannot refer to a T2S generated Settlement Instruction, unless the T2S generated Set-   |

| Reference for error message | Field or Button   | Error Text   | Description  |
|-----------------------------|---|--|--|
|                             |   |  | tlement Instruction is a recycled Reimbursement client-collateralization Settlement Instruction.   |
| MVRI592                     | <input type="checkbox"/> Actor Reference field<br><input type="checkbox"/> T2S Reference field<br><input type="checkbox"/> Instructing Party BIC field<br><input type="checkbox"/> Instructing Party Parent BIC field<br><input type="checkbox"/> Submit button | The underlying Settlement Instruction is not in CoSD Hold.   | The underlying Settlement Instruction referred by a CoSD Cancellation Instruction must be CoSD on Hold.  |
| MVRI594                     | <input type="checkbox"/> Instructing Party BIC field<br><input type="checkbox"/> Instructing Party Parent BIC field<br><input type="checkbox"/> Submit button   | The Instructing Party is not an Administering Party of any CoSD Rule associated to the Settlement Instruction. | The Instructing Party of a CoSD Cancellation Instruction must be an Administering Party of at least one of the CoSD Rules associated to the underlying Settlement Instruction. |

### 5.4.2.38 Cash Forecast - Details Screen

△ [▶ 331]

No references for error messages.

### 5.4.2.39 Cash Forecasts - Search/List Screen

△ [▶ 323]

| Reference for error message | Field or Button   | Error Text  | Description   |
|-----------------------------|---|---|---|
| QMPC017                     | <input type="checkbox"/> Intended Settlement Date field<br><input type="checkbox"/> Submit button                               | The Intended Settlement Date is not the current date or the date of the following settlement day. | The Intended Settlement Date must be the current date or the date of the following settlement day.                      |
| QMPC032                     | <input type="checkbox"/> Party BIC field<br><input type="checkbox"/> Submit button  | The specified Party BIC is not known in T2S.  | In case a Party BIC is specified, it has to be known in T2S.  |
| QMPC048                     | <input type="checkbox"/> Parent BIC field<br><input type="checkbox"/> Submit button   | The specified Parent BIC is not known in T2S.   | In case a Parent BIC is specified, it has to be known in T2S.   |
| QMPC054                     | <input type="checkbox"/> Currency field<br><input type="checkbox"/> Submit button   | The specified Currency is not known in T2S.   | In case a Currency is specified, it has to be known in T2S.   |
| QMPC084                     | <input type="checkbox"/> Party BIC field<br><input type="checkbox"/> Parent BIC field<br><input type="checkbox"/> Submit button | The specified Parent BIC is not the System Entity of the specified party.                         | In case the BIC of a party as well as its parent BIC are specified, a party with these two BICs has to be known in T2S. |

#### 5.4.2.40 Collateral Value of a Security - Search/List Screen

△ [▶ 340]

| Reference for error message | Field or Button  | Error Text   | Description  |
|-----------------------------|--|--|--|
| QMPC018                     | <input type="checkbox"/> ISIN field<br><input type="checkbox"/> Search button                              | The specified ISIN is not known in T2S.                              | In case an ISIN is specified, it has to be known in T2S.                             |
| QMPC031                     | <input type="checkbox"/> T2S Dedicated Cash Account Number field<br><input type="checkbox"/> Search button | The specified T2S Dedicated Cash Account Number is not known in T2S. | In case a T2S Dedicated Cash Account Number is specified, it has to be known in T2S. |

| Reference for error message | Field or Button   | Error Text  | Description   |
|-----------------------------|---|---|---|
| QMPC032                     | <input type="checkbox"/> Party BIC field<br><input type="checkbox"/> CSD Parent BIC field<br><input type="checkbox"/> Search button | The specified Party BIC is not known in T2S.                              | In case a Party BIC is specified, it has to be known in T2S.  |
| QMPC084                     | <input type="checkbox"/> Party BIC field<br><input type="checkbox"/> CSD Parent BIC field<br><input type="checkbox"/> Search button | The specified Parent BIC is not the System Entity of the specified party. | In case the BIC of a party as well as its parent BIC are specified, a party with these two BICs has to be known in T2S. |

#### 5.4.2.41 Collateral Value per T2S Dedicated Cash Account and Security - Search/List Screen

△ [▶ 344]

| Reference for error message | Field or Button  | Error Text  | Description   |
|-----------------------------|--|---|---|
| QMPC031                     | <input type="checkbox"/> T2S Dedicated Cash Account Number field<br><input type="checkbox"/> Search button   | The specified T2S Dedicated Cash Account Number is not known in T2S.      | In case a T2S Dedicated Cash Account Number is specified, it has to be known in T2S.                                    |
| QMPC032                     | <input type="checkbox"/> Securities Account Owner BIC field<br><input type="checkbox"/> CSD Parent BIC field<br><input type="checkbox"/> Search button | The specified Party BIC is not known in T2S.                              | In case a Party BIC is specified, it has to be known in T2S.  |
| QMPC084                     | <input type="checkbox"/> Securites Account Owner BIC field<br><input type="checkbox"/> CSD Parent BIC field<br><input type="checkbox"/> Search button  | The specified Parent BIC is not the System Entity of the specified party. | In case the BIC of a party as well as its parent BIC are specified, a party with these two BICs has to be known in T2S. |

### 5.4.2.42 Data Change - Details Screen

△ [▶ 611]

No references for error messages.

### 5.4.2.43 Data Changes - Search/List Screen

△ [▶ 607]

| Reference for error message | Field or Button  | Error Text   | Description  |
|-----------------------------|--|--|--|
| QMPC015                     | <input type="checkbox"/> From field<br><input type="checkbox"/> Search button<br><input type="checkbox"/> To field | The Date From is after the Date To.                | In case the Date is stated as a range, the Date From has to be before or equal to the Date To. |
| QMPC016                     | <input type="checkbox"/> From field<br><input type="checkbox"/> Search button                                      | The Date From is older than three calendar months. | The Date From must not be older than three calendar months.                                    |

### 5.4.2.44 Default Event Schedule - Details Screen

△

No references for error messages.

### 5.4.2.45 Hold/Release Instruction - Details Screen

△ [▶ 121]

No references for error messages.

### 5.4.2.46 Hold/Release Instruction - New Screen

△ [▶ 125]

| Reference for error message | Field or Button                        | Error Text   | Description   |
|-----------------------------|--|--|---|
| MMHI101                     | <input type="checkbox"/> Submit button | Referenced Settlement Instruction already settled. | The Settlement Status of a Settlement Instruction referenced by a Hold Instruction must not be 'Settled'. |

| Reference for error message | Field or Button  | Error Text  | Description  |
|-----------------------------|--|---|--|
| MMHI102                     | <input type="checkbox"/> Submit button   | Referenced Settlement Instruction already cancelled.  | The Cancellation Status of a Settlement Instruction referenced by a Hold Instruction must not be 'Cancelled'.  |
| MMHI104                     | <input type="checkbox"/> Party Hold field<br><input type="checkbox"/> CSD Hold field<br><input type="checkbox"/> Submit button | Referenced Settlement Instruction already on hold or there is a pending Hold instruction of the same Hold type in the system. | The relevant Hold Status (Party Hold Status or CSD Hold Status) of a Settlement Instruction referenced by a Hold Instruction must not be 'Yes'. and there must not be a pending Hold instruction of the same Hold type to be executed in the system. |
| MMHI105                     | <input type="checkbox"/> Party Hold field<br><input type="checkbox"/> CSD Hold field<br><input type="checkbox"/> Submit button | Referenced Settlement Instruction is in a CoSD group.   | The CoSD Flag of a Settlement Instruction referenced by a Hold Instruction must not be 'Yes'.  |
| MMPR201                     | <input type="checkbox"/> CoSD Release field<br><input type="checkbox"/> Submit button  | Referenced Settlement Instruction already settled.  | The Settlement Status of a Settlement Instruction referenced by a CoSD Release Instruction must not be 'Settled'.  |
| MMPR202                     | <input type="checkbox"/> CoSD Release field<br><input type="checkbox"/> Submit button  | Referenced Settlement Instruction already cancelled.  | The Cancellation Status of a Settlement Instruction referenced by a CoSD Release Instruction must not be 'Cancelled'.  |



| Reference for error message | Field or Button   | Error Text   | Description  |
|-----------------------------|---|--|--|
| MMPR203                     | <input type="checkbox"/> CoSD Rule Identification field<br><input type="checkbox"/> CoSD Release field<br><input type="checkbox"/> Submit button                                    | Waiting for CoSD cash blocking.  | The cash position of a Settlement Instruction referenced by a CoSD Release Instruction must be blocked.  |
| MMPR204                     | <input type="checkbox"/> CoSD Rule Identification field<br><input type="checkbox"/> CoSD Release field<br><input type="checkbox"/> Submit button                                    | Waiting for CoSD securities blocking.  | The securities position of a Settlement Instruction referenced by a CoSD Release Instruction must be blocked.  |
| MMPR207                     | <input type="checkbox"/> CSD Validation Hold Status<br><input type="checkbox"/> Party Hold<br><input type="checkbox"/> CoSD Release field<br><input type="checkbox"/> Submit button | Any other Hold Status apart from the CoSD Hold Status is 'Yes'.                            | The Hold statuses, except the CoSD Hold Status, of a Settlement Instruction referenced by a CoSD Release Instruction or its matched Settlement Instruction, must be 'No' |
| MMPR208                     | <input type="checkbox"/> CoSD Rule Identification field<br><input type="checkbox"/> CoSD Release field<br><input type="checkbox"/> Submit button                                    | CoSD Rule already released or there is a pending CoSD Release for this rule in the system. | The Administering Party has already requested the release of the CoSD Rule or the CoSD release for that CoSD rule is pending to be executed in the system.               |
| MMPR209                     | <input type="checkbox"/> CoSD Rule Identification field<br><input type="checkbox"/> CoSD Release field<br><input type="checkbox"/> Submit button                                    | Waiting for CoSD securities and cash blocking.   | The securities and cash position of a Settlement Instruction referenced by a CoSD Release Instruction must be blocked.   |
| MMRI201                     | <input type="checkbox"/> CoSD Release field<br><input type="checkbox"/> CSD Release field<br><input type="checkbox"/> CSD Validation Release field                                  | Referenced Settlement Instruction already settled.   | The Settlement Status of a Settlement Instruction referenced by a Release Instruction must not be 'Settled'.   |

| Reference for error message | Field or Button  | Error Text  | Description   |
|-----------------------------|--|---|---|
|                             | <ul style="list-style-type: none"> <li><input type="checkbox"/> Party Release field</li> <li><input type="checkbox"/> Submit button</li> </ul>   |   |   |
| MMRI202                     | <ul style="list-style-type: none"> <li><input type="checkbox"/> Party Release field</li> <li><input type="checkbox"/> CSD Release field</li> <li><input type="checkbox"/> CSD Validation Release field</li> <li><input type="checkbox"/> CoSD Release field</li> <li><input type="checkbox"/> Submit button</li> </ul> | Referenced Settlement Instruction already cancelled.  | The Cancellation Status of a Settlement Instruction referenced by a Release Instruction must not be 'Cancelled'.  |
| MMRI204                     | <ul style="list-style-type: none"> <li><input type="checkbox"/> Party Release field</li> <li><input type="checkbox"/> CSD Release field</li> <li><input type="checkbox"/> CSD Validation Release field</li> <li><input type="checkbox"/> CoSD Release field</li> <li><input type="checkbox"/> Submit button</li> </ul> | Referenced Settlement Instruction already released or there is a pending Release instruction of the same Hold type in the system. | The relevant Hold Status (Party Hold Status, CSD Hold Status or CSD Validation Hold Status) of a Settlement Instruction referenced by a Release Instruction must be 'Yes' and there must not be a pending Release instruction of the same Hold type to be executed in the system. |
| MVCP004                     | <ul style="list-style-type: none"> <li><input type="checkbox"/> Actor Reference field</li> <li><input type="checkbox"/> T2S Reference field</li> <li><input type="checkbox"/> Submit button</li> </ul>   | The underlying instruction referenced by a Condition Modification Instruction does not exist in T2S.                              | The underlying instruction of a Condition Modification instruction must exist in T2S.   |
| MVCP019                     | <ul style="list-style-type: none"> <li><input type="checkbox"/> Party Hold field</li> <li><input type="checkbox"/> Securities Account Number</li> <li><input type="checkbox"/> Submit button</li> </ul>  | The sender of the Hold/Release Instruction is not authorised to perform a Party Hold on the Securities Account.                   | The sender of a Hold/Release Instruction that intends to perform a Party Hold must be authorised to perform a Party Hold on a specific Securities Account.  |

| Reference for error message | Field or Button   | Error Text   | Description  |
|-----------------------------|---|--|--|
| MVCP020                     | <input type="checkbox"/> CSD Hold field<br><input type="checkbox"/> Securities Account Number<br><input type="checkbox"/> Submit button | The sender of the Hold/Release Instruction is not authorised to perform a CSD Hold on the Securities Account.    | The sender of a Hold/Release Instruction that intends to perform a CSD Hold must be authorised to perform a CSD Hold on a specific Securities Account.   |
| MVCP021                     | <input type="checkbox"/> CSD Hold field<br><input type="checkbox"/> Submit button   | The sender of the Hold/Release Instruction is not authorised to perform a CSD Hold on behalf of an external CSD. | If the relevant Depository is an external CSD, the sender of a Hold/Release Instruction that intends to perform a CSD Hold must be authorised to perform a CSD Hold on behalf of the parent CSD of the external CSD. |
| MVCP022                     | <input type="checkbox"/> Party Release field<br><input type="checkbox"/> Submit button  | The sender of the Hold/Release Instruction is not authorised to release a Party Hold on the Securities Account.  | The sender of a Hold/Release Instruction that intends to release a Party Hold must be authorised to release a Party Hold on a specific Securities Account.   |
| MVCP023                     | <input type="checkbox"/> CSD Release field<br><input type="checkbox"/> Submit button  | The sender of the Hold/Release Instruction is not authorised to release a CSD Hold on the Securities Account.    | The sender of a Hold/Release Instruction that intends to release a CSD Hold must be authorised to release a CSD Hold on a specific Securities Account.   |
| MVCP024                     | <input type="checkbox"/> CSD Validation Release field<br><input type="checkbox"/> Submit button   | The sender of the Hold/Release Instruction is not authorised to release  | The sender of a Hold/Release Instruction that intends to release a CSD Validation Hold must be authorised to   |

| Reference for error message | Field or Button   | Error Text   | Description  |
|-----------------------------|---|--|--|
|                             |   | a CSD Validation Hold on the Securities Account.   | release a CSD Validation Hold on a specific Securities Account.  |
| MVCP025                     | <input type="checkbox"/> CSD Release field<br><input type="checkbox"/> Submit button  | The sender of the Hold/Release Instruction is not authorised to release a CSD Hold on behalf of the parent CSD of the external CSD.            | If the relevant Depository is an external CSD, the sender of a Hold/Release Instruction that intends to release a CSD Hold must be authorised to release a CSD Hold on behalf of the parent CSD of the external CSD.                       |
| MVCP026                     | <input type="checkbox"/> CSD Validation Release field<br><input type="checkbox"/> Submit button   | The sender of the Hold/Release Instruction is not authorised to release a CSD Validation Hold on behalf of the parent CSD of the external CSD. | If the relevant Depository is an external CSD, the sender of a Hold/Release Instruction that intends to release a CSD Validation Hold must be authorised to release a CSD Validation Hold on behalf of the parent CSD of the external CSD. |
| MVCP043                     | <input type="checkbox"/> CoSD Rule field<br><input type="checkbox"/> CoSD Rule Identification field<br><input type="checkbox"/> Submit button | The sender of a Hold/Release Instruction is not authorised to release a CoSD Rule on Behalf of the Administering Party.                        | The sender of a Hold/Release Instruction that intends to release a CoSD Rule must be authorised to release a CoSD Rule on Behalf of the Administering Party of the rule.   |
| MVCP044                     | <input type="checkbox"/> Securities Account Number<br><input type="checkbox"/> Submit button  | The Securities Account informed in the instruction does not exist in T2S.  | The Securities Account informed in the instruction must exist in T2S.  |

| Reference for error message | Field or Button  | Error Text  | Description  |
|-----------------------------|--|---|--|
| MVCP046                     | <ul style="list-style-type: none"> <li><input type="checkbox"/> Party Hold field</li> <li><input type="checkbox"/> CSD Hold</li> <li><input type="checkbox"/> Submit button</li> </ul>   | The sender of a Hold/Release Instruction is not authorised to hold non-modifiable Instructions on behalf of the Instructing party of the Underlying Settlement Instruction    | The sender of a Hold/Release Instruction that intends to hold a Settlement Instruction identified as a non-modifiable instruction must be authorised to hold non-modifiable Instructions on behalf of the Instructing party of the Underlying Settlement Instruction       |
| MVCP047                     | <ul style="list-style-type: none"> <li><input type="checkbox"/> Party Release field</li> <li><input type="checkbox"/> CSD Release field</li> <li><input type="checkbox"/> CSD Validation Release field</li> <li><input type="checkbox"/> CoSD Release field</li> <li><input type="checkbox"/> Submit button</li> </ul> | The sender of a Hold/Release Instruction is not authorised to release non-modifiable Instructions on behalf of the Instructing party of the Underlying Settlement Instruction | The sender of a Hold/Release Instruction that intends to release a Settlement Instruction identified as a non-modifiable instruction must be authorised to release non-modifiable Instructions on behalf of the Instructing party of the Underlying Settlement Instruction |
| MVCP093                     | <ul style="list-style-type: none"> <li><input type="checkbox"/> Party Hold field</li> <li><input type="checkbox"/> Submit button</li> </ul>  | The sender of a Hold/Release Instruction is not authorised to perform a Party Hold on behalf of an external CSD.  | If the relevant Depository is an external CSD, the sender of a Hold/Release Instruction that intends to perform a Party Hold must be authorised to perform a Party Hold on behalf of that external CSD.  |
| MVCP094                     | <ul style="list-style-type: none"> <li><input type="checkbox"/> Party Release field</li> <li><input type="checkbox"/> Submit button</li> </ul>   | The sender of a Hold/Release Instruction is not authorised to release   | If the relevant Depository is an external CSD, the sender of a Hold/Release Instruction that intends to perform a  |

| Reference for error message | Field or Button   | Error Text  | Description   |
|-----------------------------|---|---|---|
|                             |   | a Party Hold on behalf of an external CSD.  | Release Party Hold must be authorised to release a Party Hold on behalf of that external CSD.   |
| MVCP106                     | <input type="checkbox"/> Hold/Release Counterparty Instruction field<br><input type="checkbox"/> Party Hold field<br><input type="checkbox"/> Securities Account Number<br><input type="checkbox"/> Submit button | The sender of a Hold/Release Instruction is not authorised to perform a Party Hold on the Securities Account of the counterparty. | The sender of a Hold/Release Instruction that intends to perform a Party Hold on both legs of an already matched Settlement Instruction must be authorised to perform a Party Hold on the Securities Account of the counterparty (in case the Hold/Release Instruction only informs one Securities Account, the other would be derived from the underlying Settlement Instruction). |
| MVCP107                     | <input type="checkbox"/> Hold/Release Counterparty Instruction field<br><input type="checkbox"/> CSD Hold field<br><input type="checkbox"/> Securities Account Number<br><input type="checkbox"/> Submit button   | The sender of a Hold/Release Instruction is not authorised to perform a CSD Hold on the Securities Account of the counterparty.   | The sender of a Hold/Release Instruction that intends to perform a CSD Hold on both legs of an already matched Settlement Instruction must be authorised to CSD Hold a Settlement Instruction on the Securities Account of the counterparty (in case the Hold/Release Instruction only informs one Securities Account, the other would be de-                                       |

| Reference for error message | Field or Button  | Error Text  | Description   |
|-----------------------------|--|---|---|
|                             |  |   | rived from the underlying Settlement Instruction).  |
| MVCP111                     | <ul style="list-style-type: none"> <li><input type="checkbox"/> Hold/Release Counterparty Instruction field</li> <li><input type="checkbox"/> Party Release field</li> <li><input type="checkbox"/> Securities Account Number</li> <li><input type="checkbox"/> Submit button</li> </ul> | The sender of a Hold/Release Instruction is not authorised to release a Party Hold on the Securities Account of the counterparty. | The sender of a Hold/Release Instruction that intends to release a Party Hold on both legs of an already matched Settlement Instruction must be authorised to release Party Hold on a Settlement Instruction of the Securities Account of the counterparty (in case the Hold/Release Instruction only informs one Securities Account, the other would be derived from the underlying Settlement Instruction). |
| MVCP112                     | <ul style="list-style-type: none"> <li><input type="checkbox"/> Hold/Release Counterparty Instruction field</li> <li><input type="checkbox"/> CSD Release field</li> <li><input type="checkbox"/> Securities Account Number</li> <li><input type="checkbox"/> Submit button</li> </ul>   | The sender of a Hold/Release Instruction is not authorised to release a CSD Hold on the Securities Account of the counterparty.   | The sender of a Hold/Release Instruction that intends to release a CSD Hold on both legs of an already matched Settlement Instruction must be authorised to release a CSD Hold of a Settlement Instruction of the Securities Account of the counterparty (in case the Hold/Release Instruction only informs one Securities Account, the other   |

| Reference for error message | Field or Button   | Error Text   | Description   |
|-----------------------------|---|--|---|
|                             |   |  | would be derived from the underlying Settlement Instruction).   |
| MVCP113                     | <ul style="list-style-type: none"> <li><input type="checkbox"/> Hold/Release Counterparty Instruction field</li> <li><input type="checkbox"/> CSD Validation Release field</li> <li><input type="checkbox"/> Securities Account Number</li> <li><input type="checkbox"/> Submit button</li> </ul> | The sender of a Hold/Release Instruction is not authorized to release a CSD Validation Hold on the Securities Account of the counterparty. | The sender of a Hold/Release Instruction that intends to release a CSD Validation Hold on both legs of an already matched Settlement Instruction must be authorized to release a CSD Validation Hold of a Settlement Instruction on the Securities Account of the counterparty (in case the Hold/Release Instruction only informs one Securities Account, the other would be derived from the underlying Settlement Instruction). |
| MVCP114                     | <ul style="list-style-type: none"> <li><input type="checkbox"/> Hold/Release Counterparty Instruction field</li> <li><input type="checkbox"/> Party Hold field</li> <li><input type="checkbox"/> Submit button</li> </ul>   | The sender of a Hold/Release Instruction is not authorized to perform a Party Hold on behalf of the external CSD of the counterparty.      | If the Depository of the counterpart is an external CSD, the sender of a Hold/Release Instruction that intends to perform a Party Hold on both legs of an already matched Settlement Instruction must be authorized to perform a Party Hold on behalf of that external CSD.   |
| MVCP115                     | <ul style="list-style-type: none"> <li><input type="checkbox"/> Hold/Release Counterparty Instruction field</li> </ul>  | The sender of a Hold/Release Instruction is not authorized to perform  | If the Depository of the counterpart is an external CSD, the sender of a Hold/Release In-   |



| Reference for error message | Field or Button   | Error Text  | Description   |
|-----------------------------|---|---|---|
|                             | <input type="checkbox"/> CSD Hold field<br><input type="checkbox"/> Submit button   | a CSD Hold on behalf of the parent CSD of the external CSD of the counterparty.   | struction that intends to perform a CSD Hold on both legs of an already matched Settlement Instruction must be authorised to CSD Hold a Settlement Instruction on behalf of the parent CSD of that external CSD.  |
| MVCP116                     | <input type="checkbox"/> Hold/Release Counterparty Instruction field<br><input type="checkbox"/> Party Hold field<br><input type="checkbox"/> Submit button | The sender of a Hold/Release Instruction is not authorized to release a Party Hold on behalf of the external CSD of the counterparty.                 | If the Depository of the counterpart is an external CSD, the sender of a Hold/Release Instruction that intends to release a Party Hold on both legs of an already matched Settlement Instruction must be authorized to release Party Hold of a Settlement Instruction on behalf that external CSD.                    |
| MVCP117                     | <input type="checkbox"/> Hold/Release Counterparty Instruction field<br><input type="checkbox"/> CSD Hold field<br><input type="checkbox"/> Submit button   | The sender of a Hold/Release Instruction is not authorized to release a CSD Hold on behalf of the parent CSD of the external CSD of the counterparty. | If the Depository of the counterpart is an external CSD, the sender of a Hold/Release Instruction that intends to release a CSD Hold on both legs of an already matched Settlement Instruction must be authorized to release a CSD Hold of a Settlement Instruction on behalf of the parent CSD of that external CSD. |

| Reference for error message | Field or Button   | Error Text   | Description   |
|-----------------------------|---|--|---|
| MVCP118                     | <ul style="list-style-type: none"> <li><input type="checkbox"/> Hold/Release Counterparty Instruction field</li> <li><input type="checkbox"/> CSD Validation Release field</li> <li><input type="checkbox"/> Submit button</li> </ul> | The sender of a Hold/Release Instruction is not authorized to release a CSD Validation Hold on behalf of the parent CSD of the external CSD of the counterparty. | If the Depository of the counterpart is an external CSD, the sender of a Hold/Release Instruction that intends to release a CSD Validation Hold on both legs of an already matched Settlement Instruction must be authorized to release a CSD Validation Hold of a Settlement Instruction on behalf of the parent CSD of that external CSD.   |
| MVCP121                     | <ul style="list-style-type: none"> <li><input type="checkbox"/> Instructing Party BIC field</li> <li><input type="checkbox"/> Instructing Party Parent BIC field</li> <li><input type="checkbox"/> Submit button</li> </ul>           | The sender of a Hold/Release Instruction is not authorised to release a CSD Validation Hold on the Securities Account of the counterparty.                       | The sender of a Hold/Release Instruction that intends to release a CSD Validation Hold on both legs of an already matched Settlement Instruction must be authorised to release a CSD Validation Hold of a Settlement Instruction on the Securities Account of the counterparty (in case the Hold/Release Instruction only informs one Securities Account, the other would be derived from the underlying Settlement Instruction). |
| MVCP129                     | <ul style="list-style-type: none"> <li><input type="checkbox"/> Party Release field</li> <li><input type="checkbox"/> Submit button</li> </ul>  | The sender of the Hold/Release Instruction is not authorised to release  | The sender of a Hold/Release Instruction that intends to release an Auto-Collateralisation  |

| Reference for error message | Field or Button   | Error Text   | Description   |
|-----------------------------|---|--|---|
|                             |   | an Auto-Collateralisation Instruction on the Securities Account.   | Instruction must be authorised to release a Party Hold on an Auto-collateralisation Instruction with specific Securities Account. |
| MVCV109                     | <input type="checkbox"/> Instructing Party BIC field<br><input type="checkbox"/> Instructing Party Parent BIC field<br><input type="checkbox"/> Submit button | The Instructing Party specified in the Hold/Release Instruction is not open on the current business date.                    | The Instructing Party specified in a Hold/Release Instruction must be open on the current business date.                          |
| MVCV233                     | <input type="checkbox"/> Instructing Party BIC field<br><input type="checkbox"/> Instructing Party Parent BIC field<br><input type="checkbox"/> Submit button | The Instructing Party BIC or Parent BIC specified in the Hold/Release Instruction is not valid on the current business date. | The Instructing Party BIC and Parent BIC indicated in a Hold/Release Instruction must be valid on the current business date.      |
| MVDC026                     | <input type="checkbox"/> Instructing Party BIC field<br><input type="checkbox"/> Instructing Party Parent BIC field<br><input type="checkbox"/> Submit button | The Instructing Party specified in the Condition Modification Instruction does not exist in T2S Static Data.                 | The Instructing Party specified in a Condition Modification Instruction must exist in T2S Static Data.                            |
| MVRI555                     | <input type="checkbox"/> T2S Reference<br><input type="checkbox"/> Submit button  | The Condition Modification Instruction refers to a T2S generated Settlement Restriction.                                     | A Condition Modification Instruction cannot refer to a T2S generated Settlement Restriction.                                      |

| Reference for error message | Field or Button  | Error Text   | Description   |
|-----------------------------|--|--|---|
| MVRI556                     | <input type="checkbox"/> Submit button   | The Cancellation Instruction refers to a T2S generated Settlement Restriction.   | A Cancellation Instruction cannot refer to a T2S generated Settlement Restriction.  |
| MVRI571                     | <input type="checkbox"/> CoSD Rule field<br><input type="checkbox"/> CoSD Rule Identification field<br><input type="checkbox"/> Submit button  | The CoSD rule reference is not informed in the CoSD Release Instruction.   | The CoSD Rule reference must be specified in a CoSD Release Instruction.  |
| MVRI572                     | <input type="checkbox"/> CoSD Rule field<br><input type="checkbox"/> CoSD Rule Identification field<br><input type="checkbox"/> Submit button  | The CoSD rule reference specified in the Release Instruction does not exist in T2S for the Settlement Instruction specified. | The CoSD Rule reference specified in a CoSD Release Instruction must exist in T2S for the Settlement Instruction stated in the Release Instruction.   |
| MVRI575                     | <input type="checkbox"/> T2S Reference<br><input type="checkbox"/> CSD Validation Hold Status<br><input type="checkbox"/> CoSD Hold Status<br><input type="checkbox"/> Submit button                           | It is not possible to amend a T2S generated Settlement Instruction.  | A Condition Modification Instruction cannot refer to a T2S generated Realignment Settlement Instruction, unless it is a CoSD Release Instruction and the T2S generated Settlement Instruction has its CoSD Hold Status Set to 'Yes' or it is a CSD. |
| MVRI584                     | <input type="checkbox"/> Instructing Party BIC field<br><input type="checkbox"/> Instructing Party Parent BIC field<br><input type="checkbox"/> CoSD Release field<br><input type="checkbox"/> CoSD Rule field | The T2S Instruction Id of a Settlement Instruction referenced by a CoSD Release Instruction is not informed.                 | When the Instructing Party of a CoSD Release Instruction is an Administering Party, the T2S Instruction Id of the underlying Settlement Instruction must be informed.   |

| Reference for error message | Field or Button  | Error Text   | Description  |
|-----------------------------|--|--|--|
|                             | <ul style="list-style-type: none"> <li><input type="checkbox"/> CoSD Rule Identification field</li> <li><input type="checkbox"/> T2S Reference</li> <li><input type="checkbox"/> Submit button</li> </ul>  |  |  |
| MVRI591                     | <ul style="list-style-type: none"> <li><input type="checkbox"/> Actor Reference field</li> <li><input type="checkbox"/> T2S Reference field</li> <li><input type="checkbox"/> Party Release field</li> <li><input type="checkbox"/> CSD Release field</li> <li><input type="checkbox"/> CSD Validation Release field</li> <li><input type="checkbox"/> CoSD Release field</li> <li><input type="checkbox"/> Submit button</li> </ul> | The Condition Modification Instruction refers to a T2S generated Settlement Instruction.                                   | A Condition Modification Instruction cannot refer to a T2S generated Collateral Settlement Instruction, unless it is a Release Instruction and the T2S generated Settlement Instruction is a Reimbursement Settlement Instruction. |
| MVRI593                     | <ul style="list-style-type: none"> <li><input type="checkbox"/> Actor Reference field</li> <li><input type="checkbox"/> T2S Reference field</li> <li><input type="checkbox"/> CoSD Release field</li> <li><input type="checkbox"/> CoSD Hold Status</li> <li><input type="checkbox"/> Submit button</li> </ul>   | The underlying Settlement Instruction is not in CoSD Hold.   | The underlying Settlement Instruction referred by a CoSD Release Instruction must be in CoSD Hold  |
| MVRI595                     | <ul style="list-style-type: none"> <li><input type="checkbox"/> Instructing Party BIC field</li> <li><input type="checkbox"/> Instructing Party Parent BIC field</li> <li><input type="checkbox"/> CoSD Release field</li> <li><input type="checkbox"/> CoSD Rule field</li> <li><input type="checkbox"/> CoSD Rule Identification field</li> <li><input type="checkbox"/> Submit button</li> </ul>                                  | The Instructing Party is not the Administering Party of the CoSD Rule specified in the Condition Modification Instruction. | The Instructing Party of a CoSD Release Instruction must be the Administering Party of the CoSD Rule specified in the condition modification message.  |

| Reference for error message | Field or Button  | Error Text   | Description  |
|-----------------------------|--|--|--|
| MVRI598                     | <input type="checkbox"/> Released Quantity<br><input type="checkbox"/> Submit button | The Settlement Quantity of a Party Release Instruction is zero or higher than the Settlement Quantity of the referenced instruction.                                       | If present, the Settlement Quantity indicated in a Party Release Instruction must be equal or lower than the Settlement Quantity stated in the referenced Settlement Instruction.  |
| MVRI599                     | <input type="checkbox"/> Released Quantity<br><input type="checkbox"/> Submit button | The Settlement Quantity of a Party Release Instruction is not a multiple of the Settlement Unit Multiple   | If present, the Settlement Quantity indicated in a Party Release Instruction must be equal or lower than the Settlement Quantity stated in the referenced Settlement Instruction.  |
| MVRI600                     | <input type="checkbox"/> Released Quantity<br><input type="checkbox"/> Submit button | The number of decimals of the Settlement Quantity of a Party Release Instruction is greater than the number of decimals of the Settlement Multiple of the related security | If present, the number of decimals of the Settlement Quantity of a Party Release Instruction must be equal or lower than the number of decimals of the Settlement Unit Multiple of the related Security                          |
| MVRI601                     | <input type="checkbox"/> Released Quantity<br><input type="checkbox"/> Submit button | The Settlement Quantity stated in the Party Release Instruction is not expressed using the same Settlement Type specified in T2S Reference Data.                           | If present, the Settlement Quantity stated in a Party Release Instruction must be expressed using the same Settlement Type as the one specified in T2S Reference Data for the ISIN Code of the referenced Settlement Instruction |

| Reference for error message | Field or Button  | Error Text   | Description  |
|-----------------------------|--|--|--|
| MVRI602                     | <input type="checkbox"/> Submit button   | The Intended Settlement Day of the referenced Settlement Instruction has not been reached yet.                 | If the quantity present in a Release Instruction is lower than the Settlement Quantity stated in the referenced Settlement Instruction, the Intended Settlement Date of the referenced Settlement Instruction must have been reached |
| MVRI603                     | <input type="checkbox"/> Submit button   | The Securities Movement type of Referenced Settlement Instruction is not 'DELI'                                | If the quantity present in a Release Instruction is lower than the Settlement Quantity stated in the referenced Settlement Instruction, the Securities Movement Type of the referenced Settlement Instruction must be 'DELI'         |
| MVRI604                     | Submit button  | The referenced Settlement Instruction of a Party Release instruction is a T2S generated Settlement Instruction | If the quantity present in a Release Instruction is lower than the Settlement Quantity stated in the referenced Settlement Instruction, the referenced Settlement Instruction must not be a T2S generated Settlement Instruction     |
| SPSA001                     | <input type="checkbox"/> Released Quantity<br><input type="checkbox"/> Submit button | Partial release instruction is denied because the relevant cut-off has been reached.                           | If the quantity present in a release Instruction is <b>L</b> ower than the settlement quantity stated in the referenced settlement instruction, the re-  |

| Reference for error message | Field or Button  | Error Text  | Description   |
|-----------------------------|--|---|---|
|                             |  |   | lated cut-off must not have been reached.<br><b>{CR-847}</b>  |
| SPSA002                     | <input type="checkbox"/> Released Quantity<br><input type="checkbox"/> Submit button | Partial release instruction is denied because it does not comply with partial settlement rules. | If the quantity present in a release instruction is lower than the settlement quantity stated in the referenced settlement instruction, it must comply with partial settlement rules.   |
| SPSA019                     | <input type="checkbox"/> Released Quantity<br><input type="checkbox"/> Submit button | At least one associated realignment Settlement Instruction is on hold.                          | If the quantity present in a Release Instruction is lower than the Settlement Quantity stated in the referenced Settlement Instruction, none of the associated realignment Settlement Instruction must be submitted to any hold |

#### 5.4.2.47 Immediate Liquidity Transfer Order - Details Screen

△ [▶ 381]

No references for error messages.

#### 5.4.2.48 Immediate Liquidity Transfer Order - New Screen

△ [▶ 386]



| Reference for error message | Field or Button  | Error Text   | Description  |
|-----------------------------|--|--|--|
| LLCI002                     | <ul style="list-style-type: none"> <li><input type="checkbox"/> T2S Dedicated Cash Account Number field (Debit)</li> <li><input type="checkbox"/> Submit button</li> </ul>   | Source (Debit) Account of internal or outbound LT is neither an existing nor an active T2S DCA.                  | The Source Account (debit account) of an immediate internal or outbound Liquidity Transfer should be an existing and active T2S Dedicated Cash Account (neither blocked nor logically deleted and for an Outbound Liquidity Transfer no RTGS Dedicated Transit Account) otherwise the incoming internal or outbound Liquidity Transfer will be rejected. |
| LLCI003                     | <ul style="list-style-type: none"> <li><input type="checkbox"/> External RTGS Account Number field</li> <li><input type="checkbox"/> T2S Dedicated Cash Account Number field (Credit)</li> <li><input type="checkbox"/> Submit button</li> </ul> | Target (Credit) Account of internal or outbound LT is neither an existing nor an active T2S DCA or RTGS Account. | The Target Account (credit account) of an internal or outbound Liquidity Transfer should be an existing and active T2S Dedicated Cash Account (neither blocked nor logically deleted) or an active RTGS account known within T2S, otherwise the incoming Liquidity Transfer will be rejected.  |
| LLCI005                     | <ul style="list-style-type: none"> <li><input type="checkbox"/> Amount field</li> <li><input type="checkbox"/> Submit button</li> </ul>  | No eligible T2S settlement currency.   | The currency of an inbound, outbound or internal Liquidity Transfer should be eligible as T2S settlement cur-  |

| Reference for error message | Field or Button  | Error Text   | Description  |
|-----------------------------|--|--|--|
|                             |  |  | rency; otherwise the Liquidity Transfer will be rejected.  |
| LLCI006                     | <ul style="list-style-type: none"> <li><input type="checkbox"/> T2S Dedicated Cash Account Number field (Debit)</li> <li><input type="checkbox"/> Amount field</li> <li><input type="checkbox"/> External RTGS Account Number field</li> <li><input type="checkbox"/> T2S Dedicated Cash Account Number field (Credit)</li> <li><input type="checkbox"/> Submit button</li> </ul>  | Currency of incoming flow differs from Target Account currency.      | The currency of the incoming flow should be the same as the currency of the target account; otherwise the incoming internal, outbound or inbound liquidity transfer will be rejected.  |
| LLCI007                     | <ul style="list-style-type: none"> <li><input type="checkbox"/> T2S Dedicated Cash Account Number field (Debit)</li> <li><input type="checkbox"/> T2S Dedicated Cash Account Number field (Credit)</li> <li><input type="checkbox"/> User Reference field</li> <li><input type="checkbox"/> Amount field</li> <li><input type="checkbox"/> External RTGS Account Number field</li> <li><input type="checkbox"/> Submit button</li> </ul> | Incoming Internal, Outbound or Inbound LT is a duplicate submission. | If the incoming Internal, outbound or Inbound Liquidity Transfer from a T2S Actor has the same Order Reference, refers to the same Debit and Credit Account and has the same instructed Amount as another Internal, Outbound or Inbound Liquidity Transfer from the same T2S Actor, then it is a duplicate submission. The second and any further submission will be rejected. |
| LLCI008                     | <ul style="list-style-type: none"> <li><input type="checkbox"/> External RTGS Account Number field</li> </ul>  | Source and Target Account of Internal LT not linked to same RTGS Ac- | Internal Liquidity Transfers are possible between T2S Dedicated Cash Accounts  |

| Reference for error message | Field or Button   | Error Text  | Description  |
|-----------------------------|---|---|--|
|                             | <ul style="list-style-type: none"> <li><input type="checkbox"/> T2S Dedicated Cash Account Number field (Credit)</li> <li><input type="checkbox"/> T2S Dedicated Cash Account Number field (Debit)</li> <li><input type="checkbox"/> Submit button</li> </ul> | <p>count or do not belong to same payment bank.</p>   | <ul style="list-style-type: none"> <li><input type="checkbox"/> linked to the same RTGS account or</li> <li><input type="checkbox"/> belonging to the same payment bank or</li> <li><input type="checkbox"/> if both accounts are T2S Central Bank accounts or</li> <li><input type="checkbox"/> if one of the accounts is a T2S Central Bank account</li> </ul> <p>If this is not the case the Internal Liquidity Transfer will be rejected.</p> <p>This rule is not applicable if one of the involved accounts is a Dedicated Transit Account.</p> |
| LLCI009                     | <ul style="list-style-type: none"> <li><input type="checkbox"/> Submit button</li> </ul>  | <p><del>LT sent between Liquidity Transfer cut off and Business Date Change.</del></p> <p><u>Liquidity Transfer sent outside acceptance time-frame.</u></p> | <p><del>Any Liquidity Transfer arriving in T2S after the Business date change and prior to the Liquidity Transfer cut-off is processed; otherwise the incoming Liquidity Transfer will be rejected. This business rule is not applicable for internal Liquidity Transfers between a RTGS Dedicated Transit Account and a Dedicated Cash Account. In case</del></p>   |

| Reference for error message | Field or Button   | Error Text  | Description  |
|-----------------------------|---|---|--|
|                             |   |   | <p><b><u>of delays in the Start of Day incoming In-bound Liquidity Transfers will be parked until the new business date is reached.</u></b></p> <p><b><u>When a Liquidity transfer enters the system outside the foreseen operating times, it is rejected. This business rule is not applicable for internal Liquidity Transfers between a RTGS Dedicated Transit Account and a Dedicated Cash Account. In case of delays in the Start of Day incoming In-bound Liquidity Transfers will be parked until the new business date is reached.</u></b>{CR-847}</p> |
| LLCI010                     | <ul style="list-style-type: none"> <li><input type="checkbox"/> T2S Dedicated Cash Account Number field (Credit)</li> <li><input type="checkbox"/> Submit button</li> </ul> | <p>Instructing Party of an Internal LT crediting an RTGS DTA is not identical with the Account holder in case of rebooking.</p> | <p>If the Target Account of an Internal Liquidity Transfer is an RTGS Dedicated Transit Account in case of rebooking, the Instructing Party should be identical with the Account holder.</p>   |

| Reference for error message | Field or Button   | Error Text  | Description   |
|-----------------------------|---|---|---|
| LLCI012                     | <input type="checkbox"/> Amount field<br><input type="checkbox"/> Submit button   | More digits after the decimal point than maximally foreseen for the currency. | The amount of the incoming flow should only contain the maximum number of digits after the decimal point as foreseen for the respective currency; otherwise the incoming Liquidity Transfer will be rejected. |
| LLCI014                     | <input type="checkbox"/> Amount field<br><input type="checkbox"/> Submit button   | The amount is lower or equal to zero.   | The amount must be greater than zero.   |
| LLCI015                     | <input type="checkbox"/> Amount field<br><input type="checkbox"/> External RTGS Account Number field<br><input type="checkbox"/> T2S Dedicated Cash Account Number field (Credit)<br><input type="checkbox"/> T2S Dedicated Cash Account Number field (Debit)<br><input type="checkbox"/> Submit button | Currency of Source Account differs from Target Account currency.              | The currency of the Source Account should be the same as the currency of the Target Account; otherwise the incoming Internal or Outbound Liquidity Transfer will be rejected.                                 |
| LLCI016                     | <input type="checkbox"/> User Reference field<br><input type="checkbox"/> Submit button   | Missing code word for processing during weekend                               | The incoming Liquidity Transfer entered the system during the weekend and does not contain the required code word.  |
| <b>LLCI017</b>              | <input type="checkbox"/> <b>User Reference field</b><br><input type="checkbox"/> <b>Submit button</b>   | <b>Reference can only contain up to 16 characters.</b>                        | <b>When performing a Liquidity Transfer for a non-Euro currency</b>   |

| Reference for error message | Field or Button  | Error Text   | Description   |
|-----------------------------|--|--|---|
|                             |  |  | <b>references may only contain up to 16 characters. {CR-847}</b>                                    |
| LLCP001                     | <input type="checkbox"/> T2S Dedicated Cash Account Number field (Debit) | Missing privilege to debit the T2S dedicated cash account. | The T2S system User must be allowed to act for the account to be debited with a Liquidity Transfer. |

#### 5.4.2.49 Immediate Liquidity Transfer Orders - Search/List Screen

△ [▶ 373]

| Reference for error message | Field or Button   | Error Text  | Description  |
|-----------------------------|---|---|--|
| QMPC015                     | <input type="checkbox"/> Settlement Date and Time - from field<br><input type="checkbox"/> Settlement Date and Time - to field<br><input type="checkbox"/> Settlement Date and Time field<br><input type="checkbox"/> Search button | The lower limit of the Cash Amount range is more than the upper limit of the Cash Amount range. | In case the Cash Amount is stated as a range, the lower limit of the Cash Amount range must be less than the upper limit of the Cash Amount range. |
| QMPC016                     | <input type="checkbox"/> Settlement Date and Time - from field<br><input type="checkbox"/> Settlement Date and Time - to field<br><input type="checkbox"/> Settlement Date and Time field   | The Date From is older than three calendar months.  | The Date From must not be older than three calendar months.  |
| QMPC031                     | <input type="checkbox"/> T2S Dedicated Cash Account Number field<br><input type="checkbox"/> Search button  | The specified T2S Dedicated Cash Account Number is not known in T2S.                            | In case a T2S Dedicated Cash Account Number is specified, it has to be known in T2S.   |

| Reference for error message | Field or Button  | Error Text   | Description  |
|-----------------------------|--|--|--|
| QMPC032                     | <input type="checkbox"/> Party BIC field<br><input type="checkbox"/> Search button   | The specified Party BIC is not known in T2S.   | In case a Party BIC is specified, it has to be known in T2S.   |
| QMPC054                     | <input type="checkbox"/> Currency field<br><input type="checkbox"/> Search button  | The specified Currency is not known in T2S.  | In case a Currency is specified, it has to be known in T2S.  |
| QMPC072                     | <input type="checkbox"/> Currency field<br><input type="checkbox"/> Parent BIC field<br><input type="checkbox"/> Party BIC field<br><input type="checkbox"/> T2S Dedicated Cash Account Number field<br><input type="checkbox"/> Search button | The specified combination of T2S Dedicated Cash Account Number, Currency, Account Owner and Account Servicer are not consistent. | In case at least two of the following selection criteria are specified, they have to be consistent, i. e. the T2S Dedicated Cash Account is owned by the specified Party <ul style="list-style-type: none"> <li>• T2S Dedicated Cash Account Number</li> <li>• Account Owner</li> <li>• Account Servicer</li> <li>• Currency, in which the T2S Dedicated Cash Account is issued and/or in which the Party owns T2SDedicated Cash Accounts</li> </ul> |
| QMPC084                     | <input type="checkbox"/> Parent BIC field<br><input type="checkbox"/> Party BIC field<br><input type="checkbox"/> Search button  | The specified Parent BIC is not the System Entity of the specified party.  | In case the BIC of a party as well as its parent BIC are specified, a party with these two BICs has to be known in T2S.  |
| QMPC097                     | <input type="checkbox"/> Settlement Date and Time - to field<br><input type="checkbox"/> Settlement Date and Time field  | In case a Date To is specified, it must not be older than three calendar months.   | The Date To is older than three calendar months.   |

### 5.4.2.50 Inbound File - Details Screen

△ [▶ 625]

No references for error messages.

### 5.4.2.51 Inbound Files - Search/List Screen

△ [▶ 622]

| Reference for error message | Field or Button  | Error Text                           | Description  |
|-----------------------------|--|--------------------------------------|--|
| QMPC015                     | <input type="checkbox"/> Entry Date and Time from field<br><input type="checkbox"/> Entry Date and Time to field<br><input type="checkbox"/> Search button | The Date From is after the Date To.  | In case the Date is stated as a range, the Date From has to be before or equal to the Date To. |
| QMPC073                     | <input type="checkbox"/> Entry Date and Time from field<br><input type="checkbox"/> Search button  | The specified Date is in the future. | In case a date from is specified, it must not be in the future.                                |

### 5.4.2.52 Inbound Message - Details Screen

△ [▶ 635]

No references for error messages.

### 5.4.2.53 Inbound Messages - Search/List Screen

△ [▶ 628]

| Reference for error message | Field or Button  | Error Text                           | Description  |
|-----------------------------|--|--------------------------------------|--|
| QMPC015                     | <input type="checkbox"/> Entry Date and Time from field<br><input type="checkbox"/> Entry Date and Time to field<br><input type="checkbox"/> Search button | The Date From is after the Date To.  | In case the Date is stated as a range, the Date From has to be before or equal to the Date To. |
| QMPC073                     | <input type="checkbox"/> Entry Business Date from field<br><input type="checkbox"/> Search button  | The specified Date is in the future. | In case a date from is specified, it must not be in the future.                                |



## 5.4.2.54 Insolvency procedure Settlement Instructions- Search/List Screen

△ [▶ 269]

| Reference for error message | Field or Button  | Error Text  | Description   |
|-----------------------------|--|---|---|
| QMPC015                     | <input type="checkbox"/> Acceptance Date and Time – from field<br><input type="checkbox"/> Acceptance Date and Time – to field<br><input type="checkbox"/> Matching Date and Time – from field<br><input type="checkbox"/> Matching Date and Time – to field<br><input type="checkbox"/> Submit button | The Date From is after the Date To.                                       | In case the Date is stated as a range, the Date From has to be before or equal to the Date To.                          |
| QMPC030                     | <input type="checkbox"/> Securities Account Number field<br><input type="checkbox"/> Submit button   | The specified Securities Account Number is not known in T2S.              | In case a Securities Account Number is specified, it has to be known in T2S.  |
| QMPC031                     | <input type="checkbox"/> Dedicated Cash Account Number field<br><input type="checkbox"/> Submit button   | The specified T2S Dedicated Cash Account Number is not known in T2S.      | In case a T2S Dedicated Cash Account Number is specified, it has to be known in T2S.                                    |
| QMPC032                     | <input type="checkbox"/> Insolvent Party BIC field<br><input type="checkbox"/> Submit button   | The specified Party BIC is not known in T2S.                              | In case a Party BIC is specified, it has to be known in T2S.  |
| QMPC048                     | <input type="checkbox"/> Insolvent Parent Party BIC field<br><input type="checkbox"/> Submit button  | The specified Parent BIC is not known in T2S.                             | In case a Parent BIC is specified, it has to be known in T2S.   |
| QMPC084                     | <input type="checkbox"/> Insolvent Party BIC field<br><input type="checkbox"/> Insolvent Parent Party BIC field<br><input type="checkbox"/> Submit button  | The specified Parent BIC is not the System Entity of the specified party. | In case the BIC of a party as well as its parent BIC are specified, a party with these two BICs has to be known in T2S. |

## 5.4.2.55 Intra-Balance Movement - Details Screen

△ [▶ 429]

No references for error messages.

## 5.4.2.56 Intra-Balance Movement - New Screen

△ [▶ 436]

| Reference for error message | Field or Button   | Error Text   | Description  |
|-----------------------------|---|--|--|
| MVCA106                     | <ul style="list-style-type: none"> <li><input type="checkbox"/> Amount field</li> <li><input type="checkbox"/> Submit button</li> <li><input type="checkbox"/> Currency field</li> </ul>  | The Currency of the Settlement Restriction is not the same as the Currency of the T2S Dedicated Cash Account.        | The Currency of a Settlement Restriction on cash must be the same as the Currency of the T2S Dedicated Cash Account.   |
| MVCA508                     | <ul style="list-style-type: none"> <li><input type="checkbox"/> Intended Settlement Date field</li> <li><input type="checkbox"/> T2S Dedicated Cash Account Number field</li> <li><input type="checkbox"/> Submit button</li> </ul>   | The T2S Dedicated Cash Account is not open on the Settlement Date.   | The T2S Dedicated Cash Account specified in a Settlement Restriction on cash must be open on the Intended Settlement Date and additionally on the current Business Day if the Intended Settlement Date is in the past. |
| MVCA512                     | <ul style="list-style-type: none"> <li><input type="checkbox"/> T2S Dedicated Cash Account Number field</li> <li><input type="checkbox"/> Submit button</li> <li><input type="checkbox"/> Account Owner BIC field</li> <li><input type="checkbox"/> T2S Dedicated Cash Account Owner field</li> </ul> | The Account Owner Party BIC of the Settlement Restriction is not the Account Owner of the T2S Dedicated Cash Account | The Account Owner Party BIC of the Settlement Restriction on Cash must be the Account Owner derived from the T2S Dedicated Cash Account in Static Data.  |
| MVCP017                     | <ul style="list-style-type: none"> <li><input type="checkbox"/> T2S Dedicated Cash Account Number field</li> </ul>  | The sender of the Settlement Restriction on Cash is not  | The sender of a Settlement Restriction on Cash must be author-   |

| Reference for error message | Field or Button   | Error Text  | Description   |
|-----------------------------|---|---|---|
|                             | <input type="checkbox"/> Submit button  | authorised to send a Settlement Restriction on Cash on the T2S Dedicated Cash Account.  | ised to send a Settlement Restriction on Cash on a specific T2S Dedicated Cash Account.   |
| MVCP018                     | <input type="checkbox"/> Submit button<br><input type="checkbox"/> Link Type<br><input type="checkbox"/> Pool Instruction Reference | The sender of the Settlement Restriction on Cash is not authorised to link to an instruction/pool belonging to another party. | In case a Settlement Restriction on Cash intends to link to another instruction or pool, the sender of the Settlement Restriction on Cash must be authorised to link to an instruction/pool belonging to a specific party.  |
| MVCP045                     | <input type="checkbox"/> Submit button<br><input type="checkbox"/> T2S Dedicated Cash Account Number field                          | The T2S Dedicated Cash Account informed in the instruction does not exist in T2S.   | The T2S Dedicated Cash Account informed in the instruction must exist in T2S.   |
| MVCP098                     | <input type="checkbox"/> Submit button<br><input type="checkbox"/> Restriction Type – Balance From field                            | The sender of the Settlement Restriction on Cash is not authorised to unblock a CoSD Cash Blocking on behalf of the CSD.      | The sender of a Settlement Restriction on Cash that tries to unblock a CoSD Cash Blocking must be authorised to send a Settlement Restriction on Cash to unblock a CoSD Cash Blocking on behalf of the relevant CSD in T2S (i.e. CSD of the debiting Settlement Instruction on whose T2S Dedicated Cash Account the cash is blocked). |

| Reference for error message | Field or Button   | Error Text  | Description  |
|-----------------------------|---|---|--|
| MVCP099                     | <input type="checkbox"/> Reference Type field<br><input type="checkbox"/> Reference field<br><input type="checkbox"/> Submit button                           | The Reference Owner of the Linked Instruction does not belong to the CSD (parent CSD in case of an external CSD) or NCB of the Instructing Party. | If a T2S actor wants to make use of linkages across several instructions sent to T2S via different CSDs or NCBs he holds accounts with, the T2S actor has to make use of the T2S reference.                      |
| MVCP120                     | <input type="checkbox"/> Instructing Party BIC field<br><input type="checkbox"/> Instructing Party Parent BIC field<br><input type="checkbox"/> Submit button | The sender of a Settlement Restriction is not authorised to send a Settlement Restriction using this Instructing Party.                           | If the sender of a Settlement Restriction does not belong to the Instructing Party, then the sender of a Settlement Restriction must be authorised to send a Settlement Restriction using the Instructing Party. |
| MVCU102                     | <input type="checkbox"/> Currency field<br><input type="checkbox"/> Submit button   | The Currency of the Settlement Restriction does not exist in T2S.   | The Currency of a Settlement Restriction on cash must exist in T2S.  |
| MVCU104                     | <input type="checkbox"/> Currency field<br><input type="checkbox"/> Submit button   | The Currency of the Settlement Restriction is not a T2S Settlement Currency.  | The Currency of a Settlement Restriction on cash must be a T2S Settlement Currency.  |
| MVCU108                     | <input type="checkbox"/> Amount field<br><input type="checkbox"/> Settlement Amount field<br><input type="checkbox"/> Submit button                           | The number of decimals of the Settlement Amount of the Settlement Restriction exceeds the number of decimals defined in T2S for the Currency      | The number of decimals of the Settlement Amount of a Settlement Restriction on cash cannot exceed the number of decimals defined T2S for the Currency stated in the Settlement Restriction.                      |

| Reference for error message | Field or Button  | Error Text   | Description  |
|-----------------------------|--|--|--|
|                             |  | stated in the Settlement Restriction.  |  |
| MVCV110                     | <ul style="list-style-type: none"> <li><input type="checkbox"/> Instructing Party BIC field</li> <li><input type="checkbox"/> Instructing Party Parent BIC field</li> <li><input type="checkbox"/> Submit button</li> <li><input type="checkbox"/> Intended settlement date</li> </ul>       | The Instructing Party specified in the Settlement Restriction is not open on the settlement date.  | The Instructing Party specified in a Settlement Restriction must be open on the Intended Settlement Date and additionally on the current Business Day if the Intended Settlement Date is in the past.                    |
| MVCV230                     | <ul style="list-style-type: none"> <li><input type="checkbox"/> Instructing Party BIC field</li> <li><input type="checkbox"/> Instructing Party Parent BIC field</li> <li><input type="checkbox"/> Intended Settlement Date field</li> <li><input type="checkbox"/> Submit button</li> </ul> | The Instructing Party BIC or Parent BIC specified in the Settlement Restriction is not valid on the settlement date.                     | The Instructing Party BIC or Parent BIC indicated in a Settlement Restriction must be valid on the Intended Settlement Date and additionally on the current Business Day if the Intended Settlement Date is in the past. |
| MVCV255                     | <ul style="list-style-type: none"> <li><input type="checkbox"/> Amount field</li> <li><input type="checkbox"/> Submit button</li> </ul>  | The Original Settlement Amount of the Settlement Restriction on cash is not greater than zero.   | The Original Settlement Amount stated in a Settlement Restriction on cash must be greater than zero.   |
| MVCV291                     | <ul style="list-style-type: none"> <li><input type="checkbox"/> T2S Dedicated Cash Account Number field</li> <li><input type="checkbox"/> Instructing Party Parent BIC field</li> <li><input type="checkbox"/> Submit button</li> </ul>  | The NCB of the Instructing Party is different than the NCB associated with the T2S Dedicated Cash Account of the Settlement Restriction. | In a Settlement Restriction on cash the NCB of the Instructing Party must be consistent with the NCB of the T2S Party owner of the T2S Dedicated Cash Account stated in the Settlement Restriction.                      |

| Reference for error message | Field or Button   | Error Text   | Description  |
|-----------------------------|---|--|--|
| MVCV292                     | <input type="checkbox"/> T2S Dedicated Cash Account Number field<br><input type="checkbox"/> Submit button  | The Dedicated Cash Account of a Settlement Restriction is a RTGS Dedicated Transit Account.  | The Dedicated Cash Account of a Settlement Restriction on Cash cannot be a RTGS Dedicated Transit Account.   |
| MVDC003                     | <input type="checkbox"/> Actor Reference field<br><input type="checkbox"/> Instructing Party BIC field<br><input type="checkbox"/> Instructing Party Parent BIC field<br><input type="checkbox"/> Submit button | An unsettled Settlement Restriction exists in T2S for the same T2S Party and the same instruction reference.   | The combination of the Instruction Reference and the Instructing Party of a Settlement Restriction must not be the same as any of the non-cancelled and non-revoked unsettled Settlement Restrictions already present in the system.             |
| MVDC005                     | <input type="checkbox"/> Actor Reference field<br><input type="checkbox"/> Instructing Party BIC field<br><input type="checkbox"/> Instructing Party Parent BIC field<br><input type="checkbox"/> Submit button | A Settlement Restriction that has been settled within a predefined number of days in the past already exists in T2S for the same T2S Party and the same instruction reference. | The combination of the Instruction Reference and the Instructing Party of a Settlement Restriction must not be the same as any Settlement Restriction present in the system that has been settled within a predefined number of days in the past |
| MVDC007                     | <input type="checkbox"/> Actor Reference field<br><input type="checkbox"/> Instructing Party BIC field<br><input type="checkbox"/> Instructing Party Parent BIC field<br><input type="checkbox"/> Submit button | A Settlement Restriction that has been cancelled within a predefined number of days in the past already exists in T2S for the same T2S   | The combination of the Instruction Reference and the Instructing Party of a Settlement Restriction must not be the same as any Settlement Restriction present in the system that has been cancelled  |

| Reference for error message | Field or Button   | Error Text   | Description   |
|-----------------------------|---|--|---|
|                             |   | Party and the same instruction reference.  | within a predefined number of days in the past.   |
| MVDC015                     | <ul style="list-style-type: none"> <li><input type="checkbox"/> Actor Reference field</li> <li><input type="checkbox"/> Instructing Party BIC field</li> <li><input type="checkbox"/> Instructing Party Parent BIC field</li> <li><input type="checkbox"/> Submit button</li> </ul> | An unsettled Settlement Instruction exists in T2S for the same T2S Party and the same instruction reference.   | The combination of the Instruction Reference and the Instructing Party of a Settlement Restriction must not be the same as any of the non-cancelled and non-revoked unsettled Settlement Instruction already present in the system.                 |
| MVDC017                     | <ul style="list-style-type: none"> <li><input type="checkbox"/> Actor Reference field</li> <li><input type="checkbox"/> Instructing Party BIC field</li> <li><input type="checkbox"/> Instructing Party Parent BIC field</li> <li><input type="checkbox"/> Submit button</li> </ul> | A Settlement Instruction that has been settled within a predefined number of days in the past already exists in T2S for the same T2S Party and the same instruction reference.   | The combination of the Instruction Reference and the Instructing Party of a Settlement Restriction must not be the same as any Settlement Instruction present in the system that has been settled within a predefined number of days in the past.   |
| MVDC019                     | <ul style="list-style-type: none"> <li><input type="checkbox"/> Actor Reference field</li> <li><input type="checkbox"/> Instructing Party BIC field</li> <li><input type="checkbox"/> Instructing Party Parent BIC field</li> <li><input type="checkbox"/> Submit button</li> </ul> | A Settlement Instruction that has been cancelled within a predefined number of days in the past already exists in T2S for the same T2S Party and the same instruction reference. | The combination of the Instruction Reference and the Instructing Party of a Settlement Restriction must not be the same as any Settlement Instruction present in the system that has been cancelled within a predefined number of days in the past. |

| Reference for error message | Field or Button   | Error Text  | Description   |
|-----------------------------|---|---|---|
| MVDC022                     | <ul style="list-style-type: none"> <li><input type="checkbox"/> Actor Reference field</li> <li><input type="checkbox"/> Instructing Party BIC field</li> <li><input type="checkbox"/> Instructing Party Parent BIC field</li> <li><input type="checkbox"/> Submit button</li> </ul>   | A Partially Settled Settlement Instruction exists in T2S for the same T2S Party and the same instruction reference. | The combination of the Instruction Reference and the Instructing Party of a Settlement Restriction must not be the same as any of the non-cancelled Partially Settled Settlement Instruction already present in the system. |
| MVDC023                     | <ul style="list-style-type: none"> <li><input type="checkbox"/> Actor Reference field</li> <li><input type="checkbox"/> Instructing Party field</li> <li><input type="checkbox"/> Instructing Party Parent BIC field</li> <li><input type="checkbox"/> Submit button</li> <li><input type="checkbox"/> Instructing Party BIC field</li> </ul> | A Partially Settled Settlement Restriction exists in T2S for the same T2S Party and the same instruction reference. | The combination of the Instruction Reference and the Instructing Party of a Settlement Restriction must not be the same as any of the non-cancelled Partially Settled Settlement Restriction already present in the system. |
| MVDC025                     | <ul style="list-style-type: none"> <li><input type="checkbox"/> Instructing Party BIC field</li> <li><input type="checkbox"/> Instructing Party Parent BIC field</li> <li><input type="checkbox"/> Instructing Party field</li> <li><input type="checkbox"/> Submit button</li> </ul>   | The Instructing Party specified in the Settlement Restriction does not exist in T2S Static Data.                    | The Instructing Party specified in a Settlement Restriction must exist in T2S Static Data.  |
| MVLI805                     | <ul style="list-style-type: none"> <li><input type="checkbox"/> Link Type field</li> <li><input type="checkbox"/> Submit button</li> </ul>  | The instruction has a Settlement link indicator 'WITH' and the existing Linked Instruction is already settled.      | The Settlement Status of a Settlement Instruction or Settlement Restriction stated as linked instruction with Link Processing Position 'WITH' in a Settlement Restriction must not be 'Settled'.                            |



| Reference for error message | Field or Button   | Error Text  | Description  |
|-----------------------------|---|---|--|
| MVLI806                     | <input type="checkbox"/> Link Type field<br><input type="checkbox"/> Submit button  | The instruction has a Settlement link indicator 'WITH' and the existing Linked Instruction is already cancelled.                                  | The Cancellation Status of a Settlement Instruction or Settlement Restriction stated as linked instruction with Link Processing Position 'WITH' in a Settlement Restriction must not be 'Cancelled'.   |
| MVLI807                     | <input type="checkbox"/> Link Type field<br><input type="checkbox"/> Submit button  | The instruction has a Settlement link indicator 'BEFORE' and the existing linked Settlement instruction is already settled                        | The Settlement Status of a Settlement Instruction or Settlement Restriction stated as linked instruction with Link Processing Position 'BEFORE' in a Settlement Restriction must not be 'Settled'.   |
| MVLI819                     | <input type="checkbox"/> Intended Settlement Date field<br><input type="checkbox"/> Link Type field<br><input type="checkbox"/> Submit button | The instruction has a Settlement link indicator 'WITH' and the Settlement link indicator included in the existing linked instruction is 'BEFORE'. | A Settlement Instruction or Settlement Restriction stated as linked 'WITH' in a Settlement Restriction must not have a previous link 'BEFORE' with the latter instruction, provided that the Intended Settlement Date in both instructions is not identical. |
| MVLI820                     | <input type="checkbox"/> Intended Settlement Date field<br><input type="checkbox"/> Link Type field<br><input type="checkbox"/> Submit button | The instruction has a Settlement link indicator 'WITH' and the Settlement link indicator included in the existing linked instruction is 'AFTER'.  | A Settlement Instruction or Settlement Restriction stated as linked 'WITH' in a Settlement Restriction must not have a previous link 'AFTER' with the latter instruction, provided   |

| Reference for error message | Field or Button   | Error Text  | Description  |
|-----------------------------|---|---|--|
|                             |   |   | that the Intended Settlement Date in both instructions is not identical.   |
| MVLI821                     | <ul style="list-style-type: none"> <li><input type="checkbox"/> Intended Settlement Date field</li> <li><input type="checkbox"/> Link Type field</li> <li><input type="checkbox"/> Submit button</li> </ul> | The instruction has a Settlement link indicator 'AFTER' and the Settlement link indicator included in the existing linked instruction is 'AFTER'.   | A Settlement Instruction or Settlement Restriction stated as linked 'AFTER' in a Settlement Restriction must not have a previous link 'AFTER' with the latter instruction, provided that the Intended Settlement Date in both instructions is not identical. |
| MVLI822                     | <ul style="list-style-type: none"> <li><input type="checkbox"/> Intended Settlement Date field</li> <li><input type="checkbox"/> Link Type field</li> <li><input type="checkbox"/> Submit button</li> </ul> | The instruction has a Settlement link indicator 'AFTER' and the Settlement link indicator included in the existing linked instruction is 'WITH'.    | A Settlement Instruction or Settlement Restriction stated as linked 'AFTER' in a Settlement Restriction must not have a previous link 'WITH' with the latter instruction, provided that the Intended Settlement Date in both instructions is not identical.  |
| MVLI823                     | <ul style="list-style-type: none"> <li><input type="checkbox"/> Intended Settlement Date field</li> <li><input type="checkbox"/> Link Type field</li> <li><input type="checkbox"/> Submit button</li> </ul> | The instruction has a Settlement link indicator 'BEFORE' and the Settlement link indicator included in the existing linked instruction is 'BEFORE'. | A Settlement Instruction or Settlement Restriction stated as linked 'BEFORE' in a Settlement Restriction must not have a previous link 'BEFORE' with the latter instruction, provided that the Intended Settlement   |

| Reference for error message | Field or Button   | Error Text  | Description  |
|-----------------------------|---|---|--|
|                             |   |   | ment Date in both instructions is not identical.   |
| MVLI824                     | <ul style="list-style-type: none"> <li><input type="checkbox"/> Intended Settlement Date field</li> <li><input type="checkbox"/> Link Type field</li> <li><input type="checkbox"/> Submit button</li> </ul> | The instruction has a Settlement link indicator 'BEFORE' and the Settlement link indicator included in the existing linked instruction is 'WITH'.                                     | A Settlement Instruction or Settlement Restriction stated as linked 'BEFORE' in a Settlement Restriction must not have a previous link 'WITH' with the latter instruction, provided that the Intended Settlement Date in both instructions is not identical. |
| MVLI834                     | <ul style="list-style-type: none"> <li><input type="checkbox"/> Link Type field</li> <li><input type="checkbox"/> Submit button</li> <li><input type="checkbox"/> Intended Settlement Date field</li> </ul> | The instruction has a Settlement link indicator 'BEFORE' and the linked instruction's Intended Settlement Date is earlier than the validating instruction's Intended Settlement Date. | The Intended Settlement Date of a Settlement Restriction must be equal to or earlier than the Intended Settlement Date of the Settlement Instruction or Settlement Restriction linked with the first one, if the Link Indicator is 'BEFORE'.                 |
| MVLI835                     | <ul style="list-style-type: none"> <li><input type="checkbox"/> Intended Settlement Date field</li> <li><input type="checkbox"/> Link Type field</li> <li><input type="checkbox"/> Submit button</li> </ul> | The instruction has a Settlement link indicator 'AFTER' and the linked instruction's Intended Settlement Date is later than the validating instruction's Intended Settlement Date.    | The Intended Settlement Date of a Settlement Restriction must be equal to or later than the Intended Settlement Date of the Settlement Instruction or Settlement Restriction linked with the first one, if the Link Indicator is 'AFTER'.                    |

| Reference for error message | Field or Button   | Error Text  | Description   |
|-----------------------------|---|---|---|
| MVLI836                     | <ul style="list-style-type: none"> <li><input type="checkbox"/> Intended Settlement Date field</li> <li><input type="checkbox"/> Link Type field</li> <li><input type="checkbox"/> Pool Instruction Identification field</li> <li><input type="checkbox"/> Submit button</li> </ul> | The instruction has either a Settlement link indicator 'WITH' or a pool reference and the linked instruction's Intended Settlement Date is different.       | The Intended Settlement Date of a Settlement Restriction must be equal to the Intended Settlement Date of the Settlement Instruction or Settlement Restriction linked with the first one, if the Link Indicator is 'WITH' or in case of Pool reference. |
| MVLI844                     | <ul style="list-style-type: none"> <li><input type="checkbox"/> Pool Instruction Counter field</li> <li><input type="checkbox"/> Submit button</li> </ul>   | The number of instructions belonging to a Pool must be the same that the Linked Instruction Counter of the Settlement Instruction or Settlement Restriction | The value of the Pool Instruction Counter stated in a Settlement Restriction must be the same as the value of the Pool Instruction Counter for such a Pool in T2S, if any instruction belonging to that Pool is present in T2S.                         |
| MVLI846                     | <ul style="list-style-type: none"> <li><input type="checkbox"/> Pool Instruction Counter field</li> <li><input type="checkbox"/> Submit button</li> </ul>   | The instruction exceeds the number of instructions of the pool.   | The number of instructions that have already been identified in T2S belonging to the Pool Reference stated in a Settlement Restriction must be lower than the Pool Instruction Counter stated in the Settlement Restriction.                            |
| MVLI848                     | <ul style="list-style-type: none"> <li><input type="checkbox"/> Pool Instruction Reference field</li> <li><input type="checkbox"/> Submit button</li> </ul>   | The instruction includes more than one Pool Reference or more than one link referring to the same instruction.  | A Settlement Restriction must not include more than one Pool Reference or more than one link referring to the same instruction.   |

| Reference for error message | Field or Button  | Error Text   | Description   |
|-----------------------------|--|--|---|
| MVLI852                     | <ul style="list-style-type: none"> <li><input type="checkbox"/> Link Type field</li> <li><input type="checkbox"/> Submit button</li> </ul> | The instruction has a Settlement link indicator 'WITH' and the existing Linked Instruction is already partially settled.   | The Settlement Status of a Settlement Instruction or Settlement Restriction stated as linked instruction with Link Processing Position 'WITH' in a Settlement Restriction must not be 'Partially Settled'   |
| MVLI855                     | <ul style="list-style-type: none"> <li><input type="checkbox"/> Link Type field</li> <li><input type="checkbox"/> Submit button</li> </ul> | The instruction has a Settlement link indicator 'BEFORE' and the existing Linked Instruction is already partially settled. | The Settlement Status of a Settlement Instruction or Settlement Restriction stated as linked instruction with Link Processing Position 'BEFORE' in a Settlement Restriction must not be 'Partially Settled' |
| MVLI858                     | <ul style="list-style-type: none"> <li><input type="checkbox"/> Link Type field</li> <li><input type="checkbox"/> Submit button</li> </ul> | The instruction has a Settlement link indicator 'AFTER' and the existing Linked Instruction is already partially settled.  | The Settlement Status of a Settlement Instruction or Settlement Restriction stated as linked instruction with Link Processing Position 'AFTER' in a Settlement Restriction must not be 'Partially Settled'  |
| MVLI861                     | <ul style="list-style-type: none"> <li><input type="checkbox"/> Link Type field</li> <li><input type="checkbox"/> Submit button</li> </ul> | The instruction has a Settlement link indicator 'AFTER' and the existing Linked Instruction is already cancelled           | The Settlement Status of a Settlement Instruction or Settlement Restriction stated as linked instruction with Link Processing Position 'AFTER' in a Settlement Restriction must not be 'Cancelled'          |

| Reference for error message | Field or Button  | Error Text  | Description   |
|-----------------------------|--|---|---|
| MVLI864                     | <input type="checkbox"/> Link Type field<br><input type="checkbox"/> Submit button   | The Linked Instruction is 'Revoked'.  | The Approval Status of a Settlement Instruction or Settlement Restriction stated as linked instruction with Link Processing Position 'WITH' in a Settlement Restriction must not be 'Revoked'                                     |
| MVLI866                     | <input type="checkbox"/> Link Type field<br><input type="checkbox"/> Submit button   | The Linked Instruction is 'Revoked'.  | The Approval Status of a Settlement Instruction or Settlement Restriction stated as linked instruction with Link Processing Position 'AFTER' in a Settlement Restriction must not be 'Revoked'                                    |
| MVLI868                     | <input type="checkbox"/> Pool Instruction Reference field<br><input type="checkbox"/> Instructing Party BIC field<br><input type="checkbox"/> Instructing Party Parent BIC field<br><input type="checkbox"/> Submit button | A Pool that has been settled within a predefined number of days in the past already exists in T2S for the same T2S Party and the same Pool Identification | The combination of the Pool Identification and the Instructing Party of a Pool must not be the same as any Pool Identification already present in the system that has been settled within a predefined number of days in the past |
| MVLI869                     | <input type="checkbox"/> Reference field<br><input type="checkbox"/> Submit button   | The Linked Instruction, referenced by a T2S Instruction Reference, does not exist.  | If the reference indicated in the linkage section is the T2S Instruction Reference, then the referenced Settlement Instruction or Settlement Restriction must exist in T2S.   |

| Reference for error message | Field or Button  | Error Text  | Description  |
|-----------------------------|--|---|--|
| MVLI873                     | <ul style="list-style-type: none"> <li><input type="checkbox"/> Reference field</li> <li><input type="checkbox"/> Submit button</li> <li><input type="checkbox"/> Link Type</li> </ul>   | The Processing Position must be specified.  | If a Settlement Restriction specifies a link with another instruction using a T2S Actor Instruction Reference or a T2S Instruction Reference, the Processing Position must be specified.   |
| MVLI876                     | <ul style="list-style-type: none"> <li><input type="checkbox"/> Link Type field</li> <li><input type="checkbox"/> Pool Instruction Reference field</li> <li><input type="checkbox"/> Submit button</li> </ul>                          | The instruction cannot be linked to a Pool with a Processing Position with AFTER or BEFORE.           | If a Settlement Restriction specifies a link to a Pool, if the Processing Position for this link is specified, it only can be WITH.  |
| MVRR901                     | <ul style="list-style-type: none"> <li><input type="checkbox"/> Restriction Type – Balance From field</li> <li><input type="checkbox"/> Submit button</li> </ul>   | The Balance From specified in the Settlement Restriction on cash does not exist in T2S.               | The Balance From specified in a Settlement Restriction on cash must exist as a Restriction Type in T2S.  |
| MVRR903                     | <ul style="list-style-type: none"> <li><input type="checkbox"/> Intended Settlement Date field</li> <li><input type="checkbox"/> Submit button</li> </ul>  | The Balance From specified in the Settlement Restriction on cash is not valid on the Settlement Date. | The Restriction Type specified in the Balance From in a Settlement Restriction on cash must be valid on the Intended Settlement Date and additionally on the current Business Date if the Intended Settlement Date is in the past. |
| MVRR905                     | <ul style="list-style-type: none"> <li><input type="checkbox"/> Restriction Type – Balance From field</li> <li><input type="checkbox"/> Restriction Type – Balance To field</li> <li><input type="checkbox"/> Submit button</li> </ul> | The Balance From and Balance To specified in the Settlement Restriction on cash have the same code.   | A Settlement Restriction on cash cannot specify the same Balance From and Balance To.  |

| Reference for error message | Field or Button  | Error Text   | Description  |
|-----------------------------|--|--|--|
| MVRR906                     | <ul style="list-style-type: none"> <li><input type="checkbox"/> Restriction Type – Balance From field</li> <li><input type="checkbox"/> Restriction Type – Balance To field</li> <li><input type="checkbox"/> Submit button</li> </ul> | The Balance From or Balance To specified in the Settlement Restriction on cash is not deliverable type.  | Either the Restriction Type specified in the Balance From or the Restriction Type specified in the Balance To in a Settlement Restriction on cash must be 'Deliverable'.   |
| MVRR910                     | <ul style="list-style-type: none"> <li><input type="checkbox"/> Restriction Type – Balance From field</li> <li><input type="checkbox"/> Restriction Type – Balance To field</li> <li><input type="checkbox"/> Submit button</li> </ul> | The Balance From and Balance To specified in the Settlement Restriction on cash do not apply on cash balance.  | The Restriction Types specified in the Balance From and Balance To in a Settlement Restriction on cash must be applicable on cash balance.   |
| MVRR916                     | <ul style="list-style-type: none"> <li><input type="checkbox"/> Restriction Type – Balance To field</li> <li><input type="checkbox"/> Submit button</li> </ul>   | The Settlement Restriction on cash sent by a T2S Actor tries to setup or increase a CoSD blocked cash balance.   | A Settlement Restriction on cash sent by a T2S Actor cannot set up or increase a CoSD blocked cash balance. (I.e. The Restriction Type specified in the Balance To in a Settlement Restriction on cash cannot be 'CoSD Blocking'). |
| MVRR917                     | <ul style="list-style-type: none"> <li><input type="checkbox"/> Restriction Type – Balance From field</li> <li><input type="checkbox"/> Submit button</li> </ul>   | The Settlement Restriction on cash sent by a T2S Actor tries to decrease a CoSD blocked cash balance and the associated CoSD Settlement Instruction is not cancelled | A Settlement Restriction on cash sent by a T2S Actor only can decrease a CoSD blocked cash balance when the related CoSD Settlement Instruction is cancelled.  |



| Reference for error message | Field or Button  | Error Text   | Description  |
|-----------------------------|--|--|--|
| MVRR918                     | <ul style="list-style-type: none"> <li><input type="checkbox"/> Restriction Reference field</li> <li><input type="checkbox"/> Submit button</li> </ul>   | The Restriction Reference specified in the Settlement Restriction on cash does not exist in T2S.   | The Restriction Reference specified in a Settlement Restriction on cash must exist in T2S.   |
| MVRR924                     | <ul style="list-style-type: none"> <li><input type="checkbox"/> Restriction Type - Balance From field</li> <li><input type="checkbox"/> Restriction Type - Balance To field</li> <li><input type="checkbox"/> Restriction Reference field</li> <li><input type="checkbox"/> Submit button</li> </ul> | The Restriction Type inferred from the Restriction Ref of the Settlement Restriction on cash is different than the Restriction Type of the impacted balance specified in the Settl. Restriction. | If a Settlement Restriction on cash specifies a Restriction Reference, the Restriction Type associated with such Restriction Reference in T2S must be the same than the Restriction Type indicated in the corresponding impacted Balance (Balance From or Balance To) in the Settlement Restriction. |
| MVRR925                     | <ul style="list-style-type: none"> <li><input type="checkbox"/> T2S Dedicated Cash Account Number field</li> <li><input type="checkbox"/> Restriction Reference field</li> <li><input type="checkbox"/> Submit button</li> </ul>   | The T2S Dedicated Cash Account inferred from the Restriction Ref of the Settl. Restriction on securities is different than the T2S Dedicated Cash Account specified in the Settl. Restriction.   | If a Settlement Restriction on cash specifies the Restriction Reference, the T2S Dedicated Cash Account associated with the Restriction Reference must be the same than the T2S Dedicated Cash Account specified in the Settlement Restriction.  |
| MVRR978                     | <ul style="list-style-type: none"> <li><input type="checkbox"/> Restriction Reference field</li> <li><input type="checkbox"/> Submit button</li> </ul>   | The Restriction Reference specified in the Settlement Restriction on cash does not apply on cash.  | The Restriction Reference specified in a Settlement Restriction on cash must apply on cash.  |

| Reference for error message | Field or Button  | Error Text   | Description  |
|-----------------------------|--|--|--|
| MVRR989                     | <ul style="list-style-type: none"> <li><input type="checkbox"/> Intended Settlement Date field</li> <li><input type="checkbox"/> Restriction Type – Balance To field</li> <li><input type="checkbox"/> Submit button</li> </ul>  | The Balance To specified in the Settlement Restriction on cash is not valid on the Settlement Date.  | The Restriction Type specified in the Balance To in a Settlement Restriction on cash must be valid on the Intended Settlement Date and additionally on the current Business Date if the Intended Settlement Date is in the past.   |
| MVRR992                     | <ul style="list-style-type: none"> <li><input type="checkbox"/> Restriction Type – Balance To field</li> <li><input type="checkbox"/> Submit button</li> </ul>   | The Balance To specified in the Settlement Restriction on cash does not exist in T2S.  | The Balance To specified in a Settlement Restriction on cash must exist as a Restriction Type in T2S.  |
| MVRR993                     | <ul style="list-style-type: none"> <li><input type="checkbox"/> Restriction Type – Balance From field</li> <li><input type="checkbox"/> Restriction Type – Balance To field</li> <li><input type="checkbox"/> Submit button</li> </ul>   | The Balance From and Balance To in the Settlement Restriction on cash have the same processing type.   | The Restriction Type specified in the Balance From and the Restriction Type specified in the Balance To in a Settlement Restriction on cash cannot belong to the same processing type (i.e. if the Balance From is deliverable the Balance to as deliverable type is not allowed). |
| MVRR994                     | <ul style="list-style-type: none"> <li><input type="checkbox"/> Restriction Type – Balance From field</li> <li><input type="checkbox"/> Restriction Type – Balance To field</li> <li><input type="checkbox"/> Restriction Reference field</li> <li><input type="checkbox"/> Submit button</li> </ul> | The Settlement Restriction on cash tries to increase or decrease a blocked, CoSD blocked or reserved cash balance without Restriction reference. | A Settlement Restriction on cash that aims to increase or decrease a blocked, CoSD blocked or reserved cash balance must include a Restriction Reference related to cash. (I.e. If the Restriction Type specified in the   |

| Reference for error message | Field or Button   | Error Text   | Description  |
|-----------------------------|---|--|--|
|                             |   |  | Balance From in a Settlement Restriction on cash is 'Blocking', 'CoSD Blocking' or 'Reservation' a Restriction Reference must be specified).                                       |
| MVSD404                     | <ul style="list-style-type: none"> <li><input type="checkbox"/> Intended Settlement Date field</li> <li><input type="checkbox"/> Submit button</li> <li><input type="checkbox"/> Amount field</li> <li><input type="checkbox"/> Currency field</li> </ul> | The Intended Settlement Date of the Settlement Restriction on cash is not a T2S Settlement Date for the Settlement Currency. | The Intended Settlement Date of a Settlement Restriction on cash must be a T2S Settlement Date for the Settlement Currency of the Settlement Restriction.                          |
| MVSP212                     | <ul style="list-style-type: none"> <li><input type="checkbox"/> Priority field</li> <li><input type="checkbox"/> Submit button</li> </ul>   | 'Reserved priority' not allowed for the Instructing Party Type (only NCBs can use it)  | 'Reserved priority' is allowed in a Settlement Restriction on Cash only if the Instructing Party is a NCB  |
| MVSR705                     | <ul style="list-style-type: none"> <li><input type="checkbox"/> Actor Reference field</li> <li><input type="checkbox"/> Submit button</li> </ul>  | Settlement Restriction rejected due to a Restriction Type  | A new Settlement Restriction that fulfills a specific restriction configured by its System Entity with positive Restriction Processing Type 'Rejection' is rejected.               |
| MVSR706                     | <ul style="list-style-type: none"> <li><input type="checkbox"/> Submit button</li> </ul>  |  | A Settlement Restriction that fulfills a specific restriction configured by its System Entity with negative Restriction Processing Type 'Rejection' is not rejected nor cancelled. |

| Reference for error message | Field or Button  | Error Text  | Description   |
|-----------------------------|--|---|---|
| MVSR708                     | <ul style="list-style-type: none"> <li><input type="checkbox"/> Actor Reference field</li> <li><input type="checkbox"/> Submit button</li> </ul> | Settlement Restriction cancelled due to a Restriction Type. | An already existing Settlement Restriction that fulfills a specific restriction configured by its System Entity with positive Restriction Processing Type 'Rejection' is cancelled. |

### 5.4.2.57 Intra-Balance Movements - Search/List Screen

△ [▶ 422]

| Reference for error message | Field or Button  | Error Text  | Description  |
|-----------------------------|--|---|--|
| IIMP079                     | <ul style="list-style-type: none"> <li><input type="checkbox"/> Restriction Type – Balance From</li> <li><input type="checkbox"/> Restriction Type – Balance To</li> </ul>   | The cash balance type of BalanceFrom must be different from the cash balance type of BalanceTo. | The cash balance type of BalanceFrom must be different from the cash balance type of BalanceTo.  |
| QMPC005                     | <ul style="list-style-type: none"> <li><input type="checkbox"/> Amount – from field</li> <li><input type="checkbox"/> Amount – to field</li> <li><input type="checkbox"/> Search button</li> </ul>                                     | The lower limit of the Cash Amount range is more than the upper limit of the Cash Amount range. | In case the Cash Amount is stated as a range, the lower limit of the Cash Amount range must be less than the upper limit of the Cash Amount range.   |
| QMPC012                     | <ul style="list-style-type: none"> <li><input type="checkbox"/> Intended Settlement Date – from field</li> <li><input type="checkbox"/> Intended Settlement Date – to field</li> <li><input type="checkbox"/> Search button</li> </ul> | The Intended Settlement Date From is after the Intended Settlement Date To.                     | In case the Intended Settlement Date is stated as a range, the Intended Settlement Date From must be before the Intended Settlement Date To, i.e. earlier or on the same day as the Intended Settlement Date To. |

| Reference for error message | Field or Button  | Error Text   | Description  |
|-----------------------------|--|--|--|
| QMPC013                     | <input type="checkbox"/> Actual Settlement Date - from field<br><input type="checkbox"/> Search button   | The requested Actual Settlement Date From is older than three calendar months. | The requested Actual Settlement Date From must not be older than three calendar months.  |
| QMPC014                     | <input type="checkbox"/> Actual Settlement Date - from field<br><input type="checkbox"/> Actual Settlement Date – to field<br><input type="checkbox"/> Search button | The Actual Settlement Date From is after the Actual Settlement Date To.        | In case the Actual Settlement Date is stated as a range, the Actual Settlement Date From must be before the Actual Settlement Date To, i.e. earlier or on the same day as the Actual Settlement Date To. |
| QMPC015                     | <input type="checkbox"/> Entry Date Time From field<br><input type="checkbox"/> Entry Date Time To field<br><input type="checkbox"/> Search button                   | The Date From is after the Date To.  | In case the Date is stated as a range, the Date From has to be before or equal to the Date To.   |
| QMPC031                     | <input type="checkbox"/> T2S Dedicated Cash Account Number field<br><input type="checkbox"/> Search button   | The specified T2S Dedicated Cash Account Number is not known in T2S.           | In case a T2S Dedicated Cash Account Number is specified, it has to be known in T2S.   |
| QMPC032                     | <input type="checkbox"/> Instructing Party BIC field<br><input type="checkbox"/> Account Owner BIC field<br><input type="checkbox"/> Search button                   | The specified Party BIC is not known in T2S.                                   | In case a Party BIC is specified, it has to be known in T2S.   |
| QMPC048                     | <input type="checkbox"/> Instructing Party Parent BIC field<br><input type="checkbox"/> Search button  | The specified Parent BIC is not known in T2S.                                  | In case a Parent BIC is specified, it has to be known in T2S.  |
| QMPC072                     | <input type="checkbox"/> T2S Dedicated Cash Account Number field   | The specified combination of T2S Dedicated Cash Account Number,                | In case at least two of the following selection criteria are specified, they have to be consist-   |

| Reference for error message | Field or Button   | Error Text  | Description   |
|-----------------------------|---|---|---|
|                             | <input type="checkbox"/> Account Owner BIC field<br><input type="checkbox"/> Search button<br><input type="checkbox"/> Currency field                         | Currency, Account Owner and Account Servicer are not consistent.          | ent, i. e. the T2S Dedicated Cash Account is owned by the specified Party<br><ul style="list-style-type: none"> <li>• T2S Dedicated Cash Account Number</li> <li>• Account Owner</li> <li>• Account Servicer</li> <li>• Currency, in which the T2S Dedicated Cash Account is issued and/or in which the Party owns T2SDedicated Cash Accounts.</li> </ul> |
| QMPC073                     | <input type="checkbox"/> Search Button<br><input type="checkbox"/> Entry Date and Time – from   | The specified Date is in the future.                                      | In case a date from is specified, it must not be in the future.   |
| QMPC084                     | <input type="checkbox"/> Instructing Party BIC field<br><input type="checkbox"/> Instructing Party Parent BIC field<br><input type="checkbox"/> Search button | The specified Parent BIC is not the System Entity of the specified party. | In case the BIC of a party as well as its parent BIC are specified, a party with these two BICs has to be known in T2S.   |
| QMPC095                     | <input type="checkbox"/> Search Button<br><input type="checkbox"/> Entry Date and Time - to   | The entry date is after the current business date.                        | In case the Entry Date To is stated, it must not be in the future.  |

### 5.4.2.58 Intra-Position Movement - Details Screen

△ [▶ 143]

No references for error messages.

### 5.4.2.59 Intra-Position Movement - New Screen

△ [▶ 150]

| Reference for error message | Field or Button  | Error Text   | Description  |
|-----------------------------|--|--|--|
| MVCP008                     | <input type="checkbox"/> Reference field   | The Party owner of the instruction/pool which the Settlement Restriction is linked to does not exist in T2S.                                       | In case a Settlement Restriction intends to link to another instruction or pool, the Party owner of the instruction/pool which the instruction is linked to must exist in T2S  |
| MVCP015                     | <input type="checkbox"/> Submit button   | The sender of the Settlement Restriction on Securities is not authorised to send a Settlement Restriction on Securities on the Securities Account. | The sender of a Settlement Restriction on Securities must be authorised to send a Settlement Restriction on Securities on a specific Securities Account.   |
| MVCP016                     | <input type="checkbox"/> T2S Reference field<br><input type="checkbox"/> Pool Instruction Identification field<br><input type="checkbox"/> Reference Owner field<br><input type="checkbox"/> Reference field<br><input type="checkbox"/> Submit button<br><input type="checkbox"/> Link Type field | The sender of the Settlement Restriction on Securities is not authorised to link to an instruction/pool belonging to another party.                | In case a Settlement Restriction on Securities intends to link to another instruction or pool, the sender of the Settlement Restriction on Securities must be authorised to link to an instruction/pool belonging to a specific party. |
| MVCP044                     | <input type="checkbox"/> Securities Account Number field<br><input type="checkbox"/> Submit button   | The Securities Account informed in the instruction does not exist in T2S.  | The Securities Account informed in the instruction must exist in T2S.  |
| MVCP051                     | <input type="checkbox"/> T2S Reference field<br><input type="checkbox"/> Reference Owner field   | The instruction to which a Settlement Instruction or a Settlement Restriction  | The instruction to which a Settlement Instruction or a Settlement Restriction is to be linked, if is   |

| Reference for error message | Field or Button   | Error Text  | Description   |
|-----------------------------|---|---|---|
|                             |   | tion is to be linked does not exist in T2S.   | referenced by a T2S Instruction Reference, must exist in T2S.   |
| MVCP097                     | <input type="checkbox"/> Instructing Party BIC field<br><input type="checkbox"/> Restriction type – balance from field<br><input type="checkbox"/> Submit button                            | The sender of the Settlement Restriction on Securities is not authorised to unblock a CoSD Securities Blocking on behalf of the CSD.              | The sender of a Settlement Restriction on Securities that tries to unblock a CoSD Securities Blocking must be authorised to send a Settlement Restriction on Securities to unblock a CoSD Securities Blocking on behalf of the relevant CSD in T2S (i.e. CSD where the securities are blocked). |
| MVCP099                     | <input type="checkbox"/> Instructing Party BIC field<br><input type="checkbox"/> Reference Type field<br><input type="checkbox"/> Reference field<br><input type="checkbox"/> Submit button | The Reference Owner of the Linked Instruction does not belong to the CSD (parent CSD in case of an external CSD) or NCB of the Instructing Party. | If a T2S actor wants to make use of linkages across several instructions sent to T2S via different CSDs or NCBs he holds accounts with, the T2S actor has to make use of the T2S reference.   |
| MVCP120                     | <input type="checkbox"/> Instructing Party BIC field<br><input type="checkbox"/> Instructing Party Parent BIC field<br><input type="checkbox"/> Submit button                               | The sender of a Settlement Restriction is not authorised to send a Settlement Restriction using this Instructing Party.                           | If the sender of a Settlement Restriction does not belong to the Instructing Party, then the sender of a Settlement Restriction must be authorised to send a Settlement Restriction using the Instructing Party.  |



| Reference for error message | Field or Button  | Error Text   | Description   |
|-----------------------------|--|--|---|
| MVCV004                     | <input type="checkbox"/> Securities Account Number field<br><input type="checkbox"/> Submit button   | The Securities Account of the Settlement Restriction does not exist in T2S.                                | The Securities Account specified in a Settlement Restriction on securities must exist in T2S.   |
| MVCV110                     | <input type="checkbox"/> Instructing Party BIC field<br><input type="checkbox"/> Instructing Party Parent BIC field<br><input type="checkbox"/> Intended settlement date<br><input type="checkbox"/> Submit button | The Instructing Party specified in the Settlement Restriction is not open on the intended settlement date. | The Instructing Party specified in a Settlement Restriction must be open on the Intended Settlement Date and additionally on the current Business Day if the Intended Settlement Date is in the past.                                     |
| MVCV124                     | <input type="checkbox"/> Intended settlement date<br><input type="checkbox"/> Securities Account Number field<br><input type="checkbox"/> Submit button  | The Account Owner derived from the securities account is not open on the settlement date.                  | The Account Owner derived from the Securities Account of a Settlement Restriction on Securities must be open on the Intended Settlement Date and additionally on the current Business Day if the Intended Settlement Date is in the past. |
| MVCV206                     | <input type="checkbox"/> ISIN field<br><input type="checkbox"/> Submit button  | The ISIN code indicated in the Settlement Restriction on securities does not exist in T2S.                 | The ISIN indicated in a Settlement Restriction on Securities must exist in T2S  |
| MVCV230                     | <input type="checkbox"/> Instructing Party BIC field<br><input type="checkbox"/> Instructing Party Parent BIC field<br><input type="checkbox"/> Intended settlement date<br><input type="checkbox"/> Submit button | The Instructing Party BIC or Parent BIC specified in the Settlement Restriction is not                     | The Instructing Party BIC or Parent BIC indicated in a Settlement Restriction must be valid on the Intended Settlement Date and additionally on the cur-  |

| Reference for error message | Field or Button   | Error Text  | Description  |
|-----------------------------|---|---|--|
|                             |   | valid on the intended settlement date.  | rent Business Day if the Intended Settlement Date is in the past.  |
| MVCV284                     | <input type="checkbox"/> Intended Settlement Date field<br><input type="checkbox"/> Securities Account Number field<br><input type="checkbox"/> Submit button   | The Securities Account of the Settlement Restriction is not valid on the intended settlement date.  | The Securities Account specified in a Settlement Restriction on securities must be open on the Intended Settlement Date and additionally on the current Business Day if the Intended Settlement Date is in the past. |
| MVCV285                     | <input type="checkbox"/> Account owner BIC field<br><input type="checkbox"/> Securities Account Number field<br><input type="checkbox"/> Submit button  | The Account Owner BIC of the Settlement Restriction on securities is not consistent with the Account Owner derived from the securities account. | The Account Owner BIC specified in a Settlement Restriction on securities must be the Account Owner derived from the Securities Account in T2S Static Data.  |
| MVCV290                     | <input type="checkbox"/> Securities Account Number field<br><input type="checkbox"/> Submit button<br><input type="checkbox"/> Instructing party parent BIC field<br><input type="checkbox"/> Instructing Party BIC field | The CSD of the Instructing Party is different than the CSD associated with the Securities Account of the Settlement Restriction.                | In a Settlement Restriction on securities the CSD of the Instructing Party must be consistent with the CSD of the T2S Party owner of the Securities Account stated in the Settlement Restriction.                    |
| MVCV302                     | <input type="checkbox"/> Intended Settlement Date field<br><input type="checkbox"/> ISIN field<br><input type="checkbox"/> Submit button  | The ISIN code indicated in the Settlement Restriction on securities is not valid on the intended settlement date.                               | The ISIN code indicated in a Settlement Restriction on securities must be valid on the Intended Settlement Date and additionally on the current date.  |

| Reference for error message | Field or Button   | Error Text  | Description  |
|-----------------------------|---|---|--|
|                             |   |   | rent Business Day if the Intended Settlement Date is in the past.  |
| MVCV304                     | <input type="checkbox"/> Intended Settlement Date field<br><input type="checkbox"/> ISIN field<br><input type="checkbox"/> Submit button  | The ISIN Code of the Settlement Instruction is not active on the Intended Settlement Date.                                  | The ISIN Code indicated in a Settlement Restriction must be active on the Intended Settlement Date and additionally on the current Business Day if the Intended Settlement Date is in the past.                                      |
| MVCV608                     | <input type="checkbox"/> Quantity field<br><input type="checkbox"/> Submit button   | The Original Settlement Quantity of the Settlement Restriction on securities is not greater than zero.                      | The Original Settlement Quantity stated in a Settlement Restriction on securities must be greater than zero.   |
| MVDC003                     | <input type="checkbox"/> Actor Reference field<br><input type="checkbox"/> Instructing Party BIC field<br><input type="checkbox"/> Instructing party parent BIC field<br><input type="checkbox"/> Submit button | An unsettled Settlement Restriction exists in T2S for the same T2S Party and the same instruction reference.                | The combination of the Instruction Reference and the Instructing Party of a Settlement Restriction must not be the same as any of the non-cancelled and non-revoked unsettled Settlement Restrictions already present in the system. |
| MVDC005                     | <input type="checkbox"/> Actor Reference field<br><input type="checkbox"/> Instructing Party BIC field<br><input type="checkbox"/> Instructing party parent BIC field<br><input type="checkbox"/> Submit button | A Settlement Restriction that has been settled within a predefined number of days in the past already exists in T2S for the | The combination of the Instruction Reference and the Instructing Party of a Settlement Restriction must not be the same as any Settlement Restriction present in the system  |

| Reference for error message | Field or Button   | Error Text   | Description   |
|-----------------------------|---|--|---|
|                             |   | same T2S Party and the same instruction reference.   | that has been settled or partially settled within a predefined number of days in the past.  |
| MVDC007                     | <ul style="list-style-type: none"> <li><input type="checkbox"/> Actor Reference field</li> <li><input type="checkbox"/> Instructing Party BIC field</li> <li><input type="checkbox"/> Instructing party parent BIC field</li> <li><input type="checkbox"/> Submit button</li> </ul> | A Settlement Restriction that has been cancelled within a predefined number of days in the past already exists in T2S for the same T2S Party and the same instruction reference. | The combination of the Instruction Reference and the Instructing Party of a Settlement Restriction must not be the same as any Settlement Restriction present in the system that has been cancelled within a predefined number of days in the past. |
| MVDC015                     | <ul style="list-style-type: none"> <li><input type="checkbox"/> Actor Reference field</li> <li><input type="checkbox"/> Instructing Party BIC field</li> <li><input type="checkbox"/> Instructing party parent BIC field</li> <li><input type="checkbox"/> Submit button</li> </ul> | An unsettled Settlement Instruction exists in T2S for the same T2S Party and the same instruction reference.   | The combination of the Instruction Reference and the Instructing Party of a Settlement Restriction must not be the same as any of the non-cancelled and non-revoked unsettled Settlement Instruction already present in the system.                 |
| MVDC017                     | <ul style="list-style-type: none"> <li><input type="checkbox"/> Actor Reference field</li> <li><input type="checkbox"/> Instructing Party BIC field</li> <li><input type="checkbox"/> Instructing party parent BIC field</li> <li><input type="checkbox"/> Submit button</li> </ul> | A Settlement Instruction that has been settled within a predefined number of days in the past already exists in T2S for the same T2S Party and the same instruction reference.   | The combination of the Instruction Reference and the Instructing Party of a Settlement Restriction must not be the same as any Settlement Instruction present in the system that has been settled   |

| Reference for error message | Field or Button   | Error Text   | Description   |
|-----------------------------|---|--|---|
|                             |   |  | within a predefined number of days in the past.   |
| MVDC019                     | <ul style="list-style-type: none"> <li><input type="checkbox"/> Actor Reference field</li> <li><input type="checkbox"/> Instructing Party BIC field</li> <li><input type="checkbox"/> Instructing party parent BIC field</li> <li><input type="checkbox"/> Submit button</li> </ul> | A Settlement Instruction that has been cancelled within a predefined number of days in the past already exists in T2S for the same T2S Party and the same instruction reference. | The combination of the Instruction Reference and the Instructing Party of a Settlement Restriction must not be the same as any Settlement Instruction present in the system that has been cancelled within a predefined number of days in the past. |
| MVDC022                     | <ul style="list-style-type: none"> <li><input type="checkbox"/> Actor Reference field</li> <li><input type="checkbox"/> Instructing Party BIC field</li> <li><input type="checkbox"/> Instructing party parent BIC field</li> <li><input type="checkbox"/> Submit button</li> </ul> | A Partially Settled Settlement Instruction exists in T2S for the same T2S Party and the same instruction reference.  | The combination of the Instruction Reference and the Instructing Party of a Settlement Restriction must not be the same as any of the non-cancelled Partially Settled Settlement Instruction already present in the system.                         |
| MVDC023                     | <ul style="list-style-type: none"> <li><input type="checkbox"/> Actor Reference field</li> <li><input type="checkbox"/> Instructing Party BIC field</li> <li><input type="checkbox"/> Instructing party parent BIC field</li> <li><input type="checkbox"/> Submit button</li> </ul> | A Partially Settled Settlement Restriction exists in T2S for the same T2S Party and the same instruction reference.  | The combination of the Instruction Reference and the Instructing Party of a Settlement Restriction must not be the same as any of the non-cancelled Partially Settled Settlement Restriction already present in the system.                         |

| Reference for error message | Field or Button   | Error Text   | Description  |
|-----------------------------|---|--|--|
| MVDC025                     | <ul style="list-style-type: none"> <li><input type="checkbox"/> Instructing Party BIC field</li> <li><input type="checkbox"/> Instructing party parent BIC field</li> <li><input type="checkbox"/> Submit button</li> </ul>   | The Instructing Party specified in the Settlement Restriction does not exist in T2S Static Data.                 | The Instructing Party specified in a Settlement Restriction must exist in T2S Static Data.   |
| MVIC306                     | <ul style="list-style-type: none"> <li><input type="checkbox"/> Intended Settlement Date field</li> <li><input type="checkbox"/> ISIN field</li> <li><input type="checkbox"/> Submit button</li> </ul>  | The ISIN Code of the Settlement Restriction is not eligible for settlement in the corresponding CSD.             | The ISIN Code of a Settlement Restriction on securities must be eligible for settlement in the corresponding CSD on the Intended Settlement Date and additionally on the current Business Day if the Intended Settlement Date is in the past.  |
| MVIC310                     | <ul style="list-style-type: none"> <li><input type="checkbox"/> Instructing Party BIC field</li> <li><input type="checkbox"/> Instructing party parent BIC field</li> <li><input type="checkbox"/> Intended Settlement Date field</li> <li><input type="checkbox"/> ISIN field</li> <li><input type="checkbox"/> Submit button</li> </ul> | The Issue Date of the Security is later than the Intended Settlement Date of the Settlement Restriction.         | When the Instructing Party is not the technical Issuer CSD or the Issuer CSD of the ISIN Code specified in a Settlement Restriction on Securities, the Intended Settlement Date of a Settlement Restriction on Securities must be equal to or later than the Issue Date of the Security. |
| MVIC312                     | <ul style="list-style-type: none"> <li><input type="checkbox"/> Instructing Party BIC field</li> <li><input type="checkbox"/> Instructing party parent BIC field</li> <li><input type="checkbox"/> Intended Settlement Date field</li> <li><input type="checkbox"/> ISIN field</li> </ul>   | The Maturity Date of the Security plus the transformation detection period is equal or earlier than the Intended | The Intended Settlement Date of a Settlement Restriction on Securities must be earlier than the Maturity Date of the Security plus the transformation detection period.  |

| Reference for error message | Field or Button  | Error Text   | Description  |
|-----------------------------|--|--|--|
|                             | <input type="checkbox"/> Submit button   | Settlement Date of the Settlement Restriction.   |  |
| MVIC314                     | <input type="checkbox"/> Instructing Party BIC field<br><input type="checkbox"/> Instructing party parent BIC field<br><input type="checkbox"/> ISIN field<br><input type="checkbox"/> Submit button | The Maturity Date of the Security plus the transformation detection period is earlier or equal than the Current Business Date. | When the Instructing Party is not the investor CSD, the technical Issuer CSD or the Issuer CSD of the ISIN Code specified in a Settlement Restriction on Securities, the Current Business Date must be earlier than the Maturity Date of the ISIN code plus the transformation detection period. |
| MVLI805                     | <input type="checkbox"/> Link Type field<br><input type="checkbox"/> Submit button   | The instruction has a Settlement link indicator 'WITH' and the existing Linked Instruction is already settled.                 | The Settlement Status of a Settlement Instruction or Settlement Restriction stated as linked instruction with Link Processing Position 'WITH' in a Settlement Restriction must not be 'Settled'.   |
| MVLI806                     | <input type="checkbox"/> Link Type field<br><input type="checkbox"/> Submit button   | The instruction has a Settlement link indicator 'WITH' and the existing Linked Instruction is already cancelled.               | The Cancellation Status of a Settlement Instruction or Settlement Restriction stated as linked instruction with Link Processing Position 'WITH' in a Settlement Restriction must not be 'Cancelled'.   |
| MVLI807                     | <input type="checkbox"/> Link Type field<br><input type="checkbox"/> Submit button   | The instruction has a Settlement link indicator 'BE-   | The Settlement Status of a Settlement Instruction or Settlement Re-  |

| Reference for error message | Field or Button   | Error Text  | Description  |
|-----------------------------|---|---|--|
|                             |   | FORE' and the existing linked Settlement instruction is already settled   | striction stated as linked instruction with Link Processing Position 'BEFORE' in a Settlement Restriction must not be 'Settled'.   |
| MVLI819                     | <ul style="list-style-type: none"> <li><input type="checkbox"/> Intended Settlement Date field</li> <li><input type="checkbox"/> Link Type field</li> <li><input type="checkbox"/> Submit button</li> </ul> | The instruction has a Settlement link indicator 'WITH' and the Settlement link indicator included in the existing linked instruction is 'BEFORE'. | A Settlement Instruction or Settlement Restriction stated as linked 'WITH' in a Settlement Restriction must not have a previous link 'BEFORE' with the latter instruction, provided that the Intended Settlement Date in both instructions is not identical. |
| MVLI820                     | <ul style="list-style-type: none"> <li><input type="checkbox"/> Intended Settlement Date field</li> <li><input type="checkbox"/> Link Type field</li> <li><input type="checkbox"/> Submit button</li> </ul> | The instruction has a Settlement link indicator 'WITH' and the Settlement link indicator included in the existing linked instruction is 'AFTER'.  | A Settlement Instruction or Settlement Restriction stated as linked 'WITH' in a Settlement Restriction must not have a previous link 'AFTER' with the latter instruction, provided that the Intended Settlement Date in both instructions is not identical.  |
| MVLI821                     | <ul style="list-style-type: none"> <li><input type="checkbox"/> Intended Settlement Date field</li> <li><input type="checkbox"/> Link Type field</li> <li><input type="checkbox"/> Submit button</li> </ul> | The instruction has a Settlement link indicator 'AFTER' and the Settlement link indicator included in the existing linked instruction is 'AFTER'. | A Settlement Instruction or Settlement Restriction stated as linked 'AFTER' in a Settlement Restriction must not have a previous link 'AFTER' with the latter instruction, provided  |



| Reference for error message | Field or Button   | Error Text  | Description  |
|-----------------------------|---|---|--|
|                             |   |   | that the Intended Settlement Date in both instructions is not identical.   |
| MVLI822                     | <ul style="list-style-type: none"> <li><input type="checkbox"/> Intended Settlement Date field</li> <li><input type="checkbox"/> Link Type field</li> <li><input type="checkbox"/> Submit button</li> </ul> | The instruction has a Settlement link indicator 'AFTER' and the Settlement link indicator included in the existing linked instruction is 'WITH'.    | A Settlement Instruction or Settlement Restriction stated as linked 'AFTER' in a Settlement Restriction must not have a previous link 'WITH' with the latter instruction, provided that the Intended Settlement Date in both instructions is not identical.    |
| MVLI823                     | <ul style="list-style-type: none"> <li><input type="checkbox"/> Intended Settlement Date field</li> <li><input type="checkbox"/> Link Type field</li> <li><input type="checkbox"/> Submit button</li> </ul> | The instruction has a Settlement link indicator 'BEFORE' and the Settlement link indicator included in the existing linked instruction is 'BEFORE'. | A Settlement Instruction or Settlement Restriction stated as linked 'BEFORE' in a Settlement Restriction must not have a previous link 'BEFORE' with the latter instruction, provided that the Intended Settlement Date in both instructions is not identical. |
| MVLI824                     | <ul style="list-style-type: none"> <li><input type="checkbox"/> Intended Settlement Date field</li> <li><input type="checkbox"/> Link Type field</li> <li><input type="checkbox"/> Submit button</li> </ul> | The instruction has a Settlement link indicator 'BEFORE' and the Settlement link indicator included in the existing linked instruction is 'WITH'.   | A Settlement Instruction or Settlement Restriction stated as linked 'BEFORE' in a Settlement Restriction must not have a previous link 'WITH' with the latter instruction, provided that the Intended Settlement Date in both instructions is not identical.   |

| Reference for error message | Field or Button   | Error Text  | Description   |
|-----------------------------|---|---|---|
| MVLI834                     | <input type="checkbox"/> Intended Settlement Date field<br><input type="checkbox"/> Link Type field<br><input type="checkbox"/> Submit button   | The instruction has a Settlement link indicator 'BEFORE' and the linked instruction's Intended Settlement Date is earlier than the validating instruction's Intended Settlement Date. | The Intended Settlement Date of a Settlement Restriction must be equal to or earlier than the Intended Settlement Date of the Settlement Instruction or Settlement Restriction linked with the first one, if the Link Indicator is 'BEFORE'.            |
| MVLI835                     | <input type="checkbox"/> Intended Settlement Date field<br><input type="checkbox"/> Link Type field<br><input type="checkbox"/> Submit button   | The instruction has a Settlement link indicator 'AFTER' and the linked instruction's Intended Settlement Date is later than the validating instruction's Intended Settlement Date.    | The Intended Settlement Date of a Settlement Restriction must be equal to or later than the Intended Settlement Date of the Settlement Instruction or Settlement Restriction linked with the first one, if the Link Indicator is 'AFTER'.               |
| MVLI836                     | <input type="checkbox"/> Intended Settlement Date field<br><input type="checkbox"/> Pool Instruction Identification field<br><input type="checkbox"/> Link Type field<br><input type="checkbox"/> Submit button | The instruction has either a Settlement link indicator 'WITH' or a pool reference and the linked instruction's Intended Settlement Date is different.                                 | The Intended Settlement Date of a Settlement Restriction must be equal to the Intended Settlement Date of the Settlement Instruction or Settlement Restriction linked with the first one, if the Link Indicator is 'WITH' or in case of Pool reference. |
| MVLI844                     | <input type="checkbox"/> Pool Instruction Counter field<br><input type="checkbox"/> Submit button   | The number of instructions belonging to a Pool must be the same that the Linked Instruc-  | The value of the Pool Instruction Counter stated in a Settlement Restriction must be the same as the value of   |

| Reference for error message | Field or Button  | Error Text   | Description  |
|-----------------------------|--|--|--|
|                             |  | tion Counter of the Settlement Instruction or Settlement Restriction   | the Pool Instruction Counter for such a Pool in T2S, if any instruction belonging to that Pool is present in T2S.  |
| MVLI846                     | <input type="checkbox"/> Pool Instruction Identification field<br><input type="checkbox"/> Submit button | The instruction exceeds the number of instructions of the pool.  | The number of instructions that have already been identified in T2S belonging to the Pool Reference stated in a Settlement Restriction must be lower than the Pool Instruction Counter stated in the Settlement Restriction. |
| MVLI848                     | <input type="checkbox"/> Pool Instruction Identification field<br><input type="checkbox"/> Submit button | The instruction includes more than one Pool Reference or more than one link referring to the same instruction.           | A Settlement Restriction must not include more than one Pool Reference or more than one link referring to the same instruction.  |
| MVLI852                     | <input type="checkbox"/> Link Type field<br><input type="checkbox"/> Submit button                       | The instruction has a Settlement link indicator 'WITH' and the existing Linked Instruction is already partially settled. | The Settlement Status of a Settlement Instruction or Settlement Restriction stated as linked instruction with Link Processing Position 'WITH' in a Settlement Restriction must not be 'Partially Settled'                    |
| MVLI855                     | <input type="checkbox"/> Submit button<br><input type="checkbox"/> Link Type field                       | The instruction has a Settlement link indicator 'BEFORE' and the ex-   | The Settlement Status of a Settlement Instruction or Settlement Restriction stated as linked instruction with Link Processing Position   |

| Reference for error message | Field or Button  | Error Text  | Description  |
|-----------------------------|--|---|--|
|                             |  | isting Linked Instruction is already partially settled.   | 'BEFORE' in a Settlement Restriction must not be 'Partially Settled'.  |
| MVLI858                     | <input type="checkbox"/> Link Type field<br><input type="checkbox"/> Submit button | The instruction has a Settlement link indicator 'AFTER' and the existing Linked Instruction is already partially settled. | The Settlement Status of a Settlement Instruction or Settlement Restriction stated as linked instruction with Link Processing Position 'AFTER' in a Settlement Restriction must not be 'Partially Settled' |
| MVLI861                     | <input type="checkbox"/> Link Type field<br><input type="checkbox"/> Submit button | The instruction has a Settlement link indicator 'AFTER' and the existing Linked Instruction is already cancelled          | The Settlement Status of a Settlement Instruction or Settlement Restriction stated as linked instruction with Link Processing Position 'AFTER' in a Settlement Restriction must not be 'Cancelled'         |
| MVLI864                     | <input type="checkbox"/> Link Type field<br><input type="checkbox"/> Submit button | The Linked Instruction is 'Revoked'.  | The Approval Status of a Settlement Instruction or Settlement Restriction stated as linked instruction with Link Processing Position 'WITH' in a Settlement Restriction must not be 'Revoked'              |
| MVLI866                     | <input type="checkbox"/> Link Type field<br><input type="checkbox"/> Submit button | The Linked Instruction is 'Revoked'.  | The Approval Status of a Settlement Instruction or Settlement Restriction stated as linked instruction with Link Processing Position   |

| Reference for error message | Field or Button  | Error Text  | Description   |
|-----------------------------|--|---|---|
|                             |  |   | 'AFTER' in a Settlement Restriction must not be 'Revoked'   |
| MVLI868                     | <ul style="list-style-type: none"> <li><input type="checkbox"/> Pool Instruction Identification field</li> <li><input type="checkbox"/> Submit button</li> </ul>   | A Pool that has been settled within a predefined number of days in the past already exists in T2S for the same T2S Party and the same Pool Identification | The combination of the Pool Identification and the Instructing Party of a Pool must not be the same as any Pool Identification already present in the system that has been settled within a predefined number of days in the past |
| MVLI869                     | <ul style="list-style-type: none"> <li><input type="checkbox"/> T2S Reference field</li> <li><input type="checkbox"/> Reference field</li> <li><input type="checkbox"/> Reference Owner field</li> <li><input type="checkbox"/> Submit button</li> </ul>   | The Linked Instruction, referenced by a T2S Instruction Reference, does not exist.  | If the Settlement Instruction stated as linked Instruction, is referenced by a T2S Instruction Reference, then the Settlement Instruction must exist in T2S   |
| MVLI873                     | <ul style="list-style-type: none"> <li><input type="checkbox"/> Link Type field</li> <li><input type="checkbox"/> T2S Reference field</li> <li><input type="checkbox"/> Reference Owner field</li> <li><input type="checkbox"/> Reference field</li> <li><input type="checkbox"/> Submit button</li> </ul> | The Processing Position must be specified.  | If a Settlement Restriction specifies a link with another instruction using a T2S Actor Instruction Reference or a T2S Instruction Reference , the Processing Position must be specified  |
| MVLI876                     | <ul style="list-style-type: none"> <li><input type="checkbox"/> Link Type field</li> <li><input type="checkbox"/> Pool Instruction Identification field</li> <li><input type="checkbox"/> Submit button</li> </ul>   | The instruction cannot be linked to a Pool with a Processing Position with AFTER or BEFORE.   | If a Settlement Restriction specifies a link to a Pool , if the Processing Position for this link is specified, it only can be WITH   |

| Reference for error message | Field or Button  | Error Text  | Description   |
|-----------------------------|--|---|---|
| MVRR902                     | <ul style="list-style-type: none"> <li><input type="checkbox"/> Restriction Type - Balance from field</li> <li><input type="checkbox"/> Submit button</li> </ul>   | The Balance From specified in the Settlement Restriction on securities does not exist in T2S.   | The Balance From specified in a Settlement Restriction on securities must exist as a Restriction Type in T2S.   |
| MVRR904                     | <ul style="list-style-type: none"> <li><input type="checkbox"/> Intended Settlement Date field</li> <li><input type="checkbox"/> Restriction Type - Balance from field</li> <li><input type="checkbox"/> Submit button</li> </ul>      | The Balance From specified in the Settlement Restriction on securities is not valid on the Intended Settlement Date.                                  | The Restriction Type specified in the Balance From in a Settlement Restriction on securities must be valid on the Intended Settlement Date and additionally on the current Business Date if the Intended Settlement Date is in the past.                  |
| MVRR907                     | <ul style="list-style-type: none"> <li><input type="checkbox"/> Restriction Type - Balance from field</li> <li><input type="checkbox"/> Restriction Type - Balance To field</li> <li><input type="checkbox"/> Submit button</li> </ul> | The Balance From or Balance To specified in the Settlement Restriction on securities have the same code.  | A Settlement Restriction on securities cannot specify the same Balance From and Balance To.   |
| MVRR908                     | <ul style="list-style-type: none"> <li><input type="checkbox"/> Restriction Type - Balance from field</li> <li><input type="checkbox"/> Restriction Type - Balance To field</li> <li><input type="checkbox"/> Submit button</li> </ul> | The Balance From or Balance To specified in the Settlement Restriction on securities is not Deliverable type, Earmarking type or Collateralized type. | Either the Restriction Type specified in the Balance From or the Restriction Type specified in the Balance To in a Settlement Restriction on securities must be 'Deliverable', 'Earmarking', 'Earmarking for Auto-Collateralisation' or 'Collateralised'. |
| MVRR909                     | <ul style="list-style-type: none"> <li><input type="checkbox"/> Restriction Type - Balance from field</li> <li><input type="checkbox"/> Restriction Type - Balance To field</li> </ul>   | The Balance From and Balance To specified in the Settlement Restriction   | The Restriction Types specified in the Balance From and Balance To in a Settlement Restriction  |

| Reference for error message | Field or Button  | Error Text  | Description  |
|-----------------------------|--|---|--|
|                             | <input type="checkbox"/> Submit button   | tion on securities do not apply on securities positions.  | on securities must be applicable on securities position.   |
| MVRR914                     | <input type="checkbox"/> Restriction Type - Balance To field<br><input type="checkbox"/> Submit button   | The Settlement Restriction on securities sent by a T2S Actor tries to set up or increase a CoSD blocked position or a Collateralized position | A Settlement Restriction on Securities sent by a T2S Actor cannot set up or increase a CoSD Blocked position or a Collateralized position. (I.e. The Restriction Type specified in the Balance To in a Settlement Restriction on Securities cannot be 'CoSD Blocking or 'Collateralized'). |
| MVRR915                     | <input type="checkbox"/> Restriction Type - Balance from field<br><input type="checkbox"/> Submit button | The Settlement Restriction on securities sent by a T2S Actor tries to decrease a CoSD blocked position or a Collateralized position.          | A Settlement Restriction on Securities sent by a T2S Actor cannot decrease a CoSD Blocked position or Collateralized position. (I.e. The Restriction Type specified in the Balance From in a Settlement Restriction on Securities cannot be 'CoSD Blocking' or 'Collateralised')           |
| MVRR919                     | <input type="checkbox"/> Restriction Reference field<br><input type="checkbox"/> Submit button           | The Restriction Reference specified in the Settlement Restriction on securities does not exist in T2S.  | The Restriction Reference specified in a Settlement Restriction on securities must exist in T2S.   |

| Reference for error message | Field or Button  | Error Text   | Description  |
|-----------------------------|--|--|--|
| MVRR921                     | <ul style="list-style-type: none"> <li><input type="checkbox"/> Restriction Type - Balance from field</li> <li><input type="checkbox"/> Restriction Type - Balance To field</li> <li><input type="checkbox"/> Restriction Reference field</li> <li><input type="checkbox"/> Submit button</li> </ul> | The Restriction Type inferred from the Restriction Ref of the Settlement Restriction on securities is different than the Restriction Type of the impacted balance specified in the Settl. Restriction. | If a Settlement Restriction on securities specifies a Restriction Reference, the Restriction Type associated with such Restriction Reference in T2S must be the same than the Restriction Type indicated in the corresponding impacted Balance (Balance From or Balance To) in the Settlement Restriction. |
| MVRR922                     | <ul style="list-style-type: none"> <li><input type="checkbox"/> Securities Account Number field</li> <li><input type="checkbox"/> Restriction Reference field</li> <li><input type="checkbox"/> Submit button</li> </ul>   | The securities Account inferred from the Restriction Reference of the Settlement Restriction on securities is different than the securities account specified in the Settlement Restriction.           | If a Settlement Restriction on securities specifies the Restriction Reference, the securities account associated with the Restriction Reference must be the same than the securities account specified in the Settlement Restriction.  |
| MVRR923                     | <ul style="list-style-type: none"> <li><input type="checkbox"/> ISIN field</li> <li><input type="checkbox"/> Restriction Reference field</li> <li><input type="checkbox"/> Submit button</li> </ul>  | The security associated inferred from the Restriction Reference of the Settlement Restriction on securities is different than the security specified in the Settlement Restriction.                    | If a Settlement Restriction on securities specifies the Restriction Reference, the security associated with the Restriction Reference must be the same than the security specified in the Settlement Restriction.  |
| MVRR954                     | <ul style="list-style-type: none"> <li><input type="checkbox"/> Restriction Type - Balance from field</li> </ul>   | The Settlement Restriction on securities tries to de-  | A Settlement Restriction on securities that aims decrease a  |



| Reference for error message | Field or Button  | Error Text  | Description   |
|-----------------------------|--|---|---|
|                             | <ul style="list-style-type: none"> <li><input type="checkbox"/> Restriction Reference field</li> <li><input type="checkbox"/> Submit button</li> </ul>   | crease a blocked, CoSD blocked or reserved securities position without Restriction reference  | blocked, CoSD blocked or reserved securities position must include a Restriction Reference related to securities (I.e. If the Restriction Type specified in the Balance From in a Settlement Restriction on securities is 'Blocking' , 'CoSD blocked or 'Reservation', a Restriction Reference must be specified).                      |
| MVRR970                     | <ul style="list-style-type: none"> <li><input type="checkbox"/> Restriction Type - Balance from field</li> <li><input type="checkbox"/> Restriction Type - Balance To field</li> <li><input type="checkbox"/> Restriction Reference field</li> <li><input type="checkbox"/> Submit button</li> </ul> | The Restriction Reference is specified and the Settlement Restriction on securities tries to increase or set up an Earmarking or Collateralized position from a deliverable position. | If the Restriction Type specified in the Balance From in a Settlement Restriction on securities is 'Deliverable' and the Restriction Type specified in the Balance To is 'Earmarking' or is 'Earmarking for auto collateralization' or 'Collateralized', the Restriction Reference must not be specified in the Settlement Restriction. |
| MVRR971                     | <ul style="list-style-type: none"> <li><input type="checkbox"/> Restriction Type - Balance from field</li> <li><input type="checkbox"/> Restriction Type - Balance To field</li> <li><input type="checkbox"/> Restriction Reference field</li> <li><input type="checkbox"/> Submit button</li> </ul> | The Restriction Reference is specified and the Settlement Restriction on securities tries to decrease an Earmarking or Collateralized position to a deliverable position.             | If the Restriction Type specified in the Balance From in a Settlement Restriction on securities is 'Earmarking' or 'Earmarking for auto collateralization' or 'Collateralized' and the Restriction Type specified in the Balance To is 'De-   |

| Reference for error message | Field or Button  | Error Text  | Description   |
|-----------------------------|--|---|---|
|                             |  |   | liverable', the Restriction Reference must not be specified in the Settlement Restriction.  |
| MVRR979                     | <ul style="list-style-type: none"> <li><input type="checkbox"/> Restriction Type - Balance from field</li> <li><input type="checkbox"/> Restriction Type - Balance To field</li> <li><input type="checkbox"/> Submit button</li> </ul>   | The Balance From and Balance To in the Settlement Restriction on securities have the same processing type.                                | The Restriction Type specified in the Balance From and the Restriction Type specified in the Balance To in a Settlement Restriction on securities cannot belong to the same processing type except for earmarking processing type (i.e. if the Balance From is earmarking type the Balance to as earmarking type is allowed). |
| MVRR980                     | <ul style="list-style-type: none"> <li><input type="checkbox"/> Restriction Type - Balance from field</li> <li><input type="checkbox"/> Restriction Type - Balance To field</li> <li><input type="checkbox"/> Restriction Reference field</li> <li><input type="checkbox"/> Submit button</li> </ul> | The Restriction Reference is specified and the Settlement Restriction on securities tries to decrease or increase an Earmarking position. | If the Restriction Type specified in the Balance From in a Settlement Restriction on securities is 'Earmarking' and the Restriction Type specified in the Balance To is 'Earmarking for auto collateralization' or vice versa, the Restriction Reference must not be specified in the Settlement Restriction.                 |
| MVRR981                     | <ul style="list-style-type: none"> <li><input type="checkbox"/> Restriction Type - Balance from field</li> <li><input type="checkbox"/> Restriction Type - Balance To field</li> </ul>   | The Restriction Reference is specified and the Settlement Restriction on securities tries   | If the Restriction Type specified in the Balance From in a Settlement Restriction on securities is 'Earmarking for auto collateralization' and  |

| Reference for error message | Field or Button   | Error Text  | Description  |
|-----------------------------|---|---|--|
|                             | <ul style="list-style-type: none"> <li><input type="checkbox"/> Restriction Reference field</li> <li><input type="checkbox"/> Submit button</li> </ul>  | to decrease or increase a Collateralized position.  | the Restriction Type specified in the Balance To is 'Collateralized' or vice versa, the Restriction Reference must not be indicated in the Settlement Restriction.   |
| MVRR982                     | <ul style="list-style-type: none"> <li><input type="checkbox"/> Restriction Reference field</li> <li><input type="checkbox"/> Submit button</li> </ul>  | The Restriction Reference specified in the Settlement Restriction on securities does not apply on securities.             | The Restriction Reference specified in a Settlement Restriction on securities must apply on securities.  |
| MVRR990                     | <ul style="list-style-type: none"> <li><input type="checkbox"/> Restriction Type - Balance To field</li> <li><input type="checkbox"/> Submit button</li> </ul>  | The Balance To specified in the Settlement Restriction on securities does not exist in T2S.                               | The Balance To specified in a Settlement Restriction on securities must exist as a Restriction Type in T2S.  |
| MVRR991                     | <ul style="list-style-type: none"> <li><input type="checkbox"/> Intended Settlement Date field</li> <li><input type="checkbox"/> Restriction Type - Balance To field</li> <li><input type="checkbox"/> Submit button</li> </ul> | The Balance To specified in the Settlement Restriction on securities is not valid on the Intended Settlement Date.        | The Restriction Type specified in the Balance To in a Settlement Restriction on securities must be valid on the Intended Settlement Date and additionally on the current Business Date if the Intended Settlement Date is in the past. |
| MVRR995                     | <ul style="list-style-type: none"> <li><input type="checkbox"/> Restriction Type - Balance from field</li> <li><input type="checkbox"/> Submit button</li> </ul>  | The Settlement Restriction on securities sent by a T2S Actor tries to decrease a CoSD blocked securities position and the | A Settlement Restriction on Securities sent by a T2S Actor only can decrease a CoSD blocked securities posi-   |

| Reference for error message | Field or Button   | Error Text   | Description   |
|-----------------------------|---|--|---|
|                             |   | associated CoSD Settlement Instruction is not cancelled.   | tion when the related CoSD Settlement Instruction is cancelled.   |
| MVSD402                     | <input type="checkbox"/> Intended Settlement Date field<br><input type="checkbox"/> Submit button   | The Creation Date is later than the Intended Settlement Date of the Settlement Restriction.                              | The Creation Date of a Settlement Restriction has to be equal to or earlier than its Intended Settlement Date.  |
| MVSD405                     | <input type="checkbox"/> Intended Settlement Date field<br><input type="checkbox"/> Submit button   | The Intended Settlement Date of the Settlement Restriction on securities is Saturday, Sunday or a Closing Day in T2S.    | The Intended Settlement Date of a Settlement Restriction on securities must be a day from Monday to Friday and a Business Date in T2S   |
| MVSP210                     | <input type="checkbox"/> Instructing Party BIC field<br><input type="checkbox"/> Priority field<br><input type="checkbox"/> Submit button | 'Reserved priority' not allowed for the Instructing Party Type (only CSDs can use it)                                    | 'Reserved priority' is allowed in a Settlement Restriction on Securities only if the Instructing Party is a CSD   |
| MVSQL603                    | <input type="checkbox"/> ISIN field<br><input type="checkbox"/> Quantity field<br><input type="checkbox"/> Submit button                  | The settlement type stated in the Restriction is not the same as the Type of Settlement specified in T2S Reference Data. | The Settlement Type stated in the Settlement Quantity of a Settlement Restriction on Securities must be the same as the Settlement Type specified in T2S Reference Data for the ISIN Code of the Restriction. |
| MVSQL605                    | <input type="checkbox"/> ISIN field<br><input type="checkbox"/> Quantity field<br><input type="checkbox"/> Submit button                  | The Settlement Quantity of the Settlement Restriction is lower than the Minimum Settlement Unit                          | The Settlement Quantity specified in a Settlement Restriction on securities must be equal   |

| Reference for error message | Field or Button  | Error Text  | Description   |
|-----------------------------|--|---|---|
|                             |  |   | or greater than the Minimum Settlement Unit specified in T2S.   |
| MVSQ607                     | <input type="checkbox"/> Corporate Action Event Id field<br><input type="checkbox"/> ISIN field<br><input type="checkbox"/> Quantity field<br><input type="checkbox"/> Submit button | The Settlement Quantity of the Settlement Restriction is neither a multiple of Settlement Unit Multiple nor a Deviating Settlement Unit.                                  | The Settlement Quantity of a Settlement Restriction on securities and not related to a 'Corporate Action' must be a multiple of the Settlement Unit Multiple or a Deviating Settlement Unit.                                      |
| MVSQ611                     | <input type="checkbox"/> Corporate Action Event Id field<br><input type="checkbox"/> Submit button   | The remaining Settlement Quantity of the Settlement Restriction is neither a multiple of Settlement Unit Multiple nor a Deviating Settlement Unit                         | In case of a partially settled Settlement Restriction on Securities and not related to a 'Corporate Action', the remaining Settlement Quantity must be a multiple of the Settlement Unit Multiple or a Deviating Settlement Unit. |
| MVSQ613                     | <input type="checkbox"/> Quantity<br><input type="checkbox"/> Settlement Type<br><input type="checkbox"/> Submit button  | The number of decimals of the Settlement Quantity of the Settlement Restriction is greater than the number of decimals of the Settlement Multiple of the related security | The number of decimals of the Settlement Quantity of a Settlement Restriction on Securities must be equal or lower than the number of decimals of the Settlement Unit Multiple of the related Security.                           |
| MVSR705                     | <input type="checkbox"/> Submit button<br><input type="checkbox"/> Actor reference   | Settlement Restriction rejected due to a Restriction Type.  | A new Settlement Restriction that fulfills a specific restriction configured by its System Entity with positive Re-   |

| Reference for error message | Field or Button  | Error Text  | Description  |
|-----------------------------|--|---|--|
|                             |  |   | striction Processing Type 'Rejection' is rejected.   |
| MVSR706                     | <input type="checkbox"/> Submit button   |   | A Settlement Restriction that fulfils a specific restriction configured by its System Entity with negative Restriction Processing Type 'Rejection' is not rejected nor cancelled.  |
| MVSR708                     | <input type="checkbox"/> Submit button<br><input type="checkbox"/> Actor reference | Settlement Restriction cancelled due to a Restriction Type. | An already existing Settlement Restriction that fulfils a specific restriction configured by its System Entity with positive Restriction Processing Type 'Rejection' is cancelled. |

#### 5.4.2.60 Intra-Position Movements - Search/List Screen

△ [▶ 136]

| Reference for error message | Field or Button  | Error Text  | Description  |
|-----------------------------|--|---|--|
| IIMP102                     | <input type="checkbox"/> Restriction Type Balance from field<br><input type="checkbox"/> Restriction Type Balance to field | The securities balance type of BalanceFrom must be different from the securities balance type of BalanceTo. | The securities balance type of BalanceFrom must be different from the securities balance type of BalanceTo.              |
| QMPC006                     | <input type="checkbox"/> Quantity or nominal securities – from field   | The lower limit of the Securities Quantity range is greater than the  | In case the Securities Quantity is stated as a range, the lower limit of the Securities Quantity range must be less than |

| Reference for error message | Field or Button  | Error Text  | Description  |
|-----------------------------|--|---|--|
|                             | <input type="checkbox"/> Quantity or nominal securities – to field<br><input type="checkbox"/> Search button   | upper limit of the Securities Quantity range.                               | the upper limit of the Securities Quantity range.  |
| QMPC012                     | <input type="checkbox"/> Intended Settlement Date – from field<br><input type="checkbox"/> Intended Settlement Date – to field<br><input type="checkbox"/> Search button | The Intended Settlement Date From is after the Intended Settlement Date To. | In case the Intended Settlement Date is stated as a range, the Intended Settlement Date From must be before the Intended Settlement Date To, i.e. earlier or on the same day as the Intended Settlement Date To. |
| QMPC013                     | <input type="checkbox"/> Actual Settlement Date – from field<br><input type="checkbox"/> Search button   | The requested Actual Settlement Date From is older than 90 business days.   | The requested Actual Settlement Date From must not be older than 90 business days.   |
| QMPC014                     | <input type="checkbox"/> Actual Settlement Date – from field<br><input type="checkbox"/> Actual Settlement Date – to field<br><input type="checkbox"/> Search button     | The Actual Settlement Date From is after the Actual Settlement Date To.     | In case the Actual Settlement Date is stated as a range, the Actual Settlement Date From must be before the Actual Settlement Date To, i.e. earlier or on the same day as the Actual Settlement Date To.         |
| QMPC015                     | <input type="checkbox"/> Search button<br><input type="checkbox"/> Entry Date Time – from field<br><input type="checkbox"/> Entry Date Time – to field                   | The Date From is after the Date To.   | In case the Date is stated as a range, the Date From has to be before or equal to the Date To.   |
| QMPC018                     | <input type="checkbox"/> ISIN field<br><input type="checkbox"/> Search button  | The specified ISIN is not known in T2S.                                     | In case an ISIN is specified, it has to be known in T2S.   |

| Reference for error message | Field or Button   | Error Text  | Description   |
|-----------------------------|---|---|---|
| QMPC030                     | <input type="checkbox"/> Securities Account Number field<br><input type="checkbox"/> Search button  | The specified Securities Account Number is not known in T2S.              | In case a Securities Account Number is specified, it has to be known in T2S.  |
| QMPC032                     | <input type="checkbox"/> Instructing Party BIC field<br><input type="checkbox"/> Securities Account Owner BIC field<br><input type="checkbox"/> Search button | The specified Party BIC is not known in T2S.                              | In case a Party BIC is specified, it has to be known in T2S.  |
| QMPC048                     | <input type="checkbox"/> Instructing Party Parent BIC field<br><input type="checkbox"/> Search button   | The specified Parent BIC is not known in T2S.                             | In case a Parent BIC is specified, it has to be known in T2S.   |
| QMPC073                     | <input type="checkbox"/> Search button<br><input type="checkbox"/> Entry Date Time – from field   | The specified Date is in the future.                                      | In case a date from is specified, it must not be in the future.   |
| QMPC084                     | <input type="checkbox"/> Instructing Party BIC field<br><input type="checkbox"/> Instructing Party Parent BIC field<br><input type="checkbox"/> Search button | The specified Parent BIC is not the System Entity of the specified party. | In case the BIC of a party as well as its parent BIC are specified, a party with these two BICs has to be known in T2S. |
| QMPC095                     | <input type="checkbox"/> Search button<br><input type="checkbox"/> Entry Date Time – to field   | The entry date is after the current business date.                        | In case the Entry Date To is stated, it must not be in the future.  |

### 5.4.2.61 Limit Utilisation - Search/List Screen

△ [▶ 348]

| Reference for error message | Field or Button   | Error Text  | Description   |
|-----------------------------|---|---|---|
| QMPC036                     | <input type="checkbox"/> Identification field<br><input type="checkbox"/> Search button | The specified Limit Identification is not known in T2S. | In case a Limit Identifier is specified, it has to be known in T2S. |



| Reference for error message | Field or Button   | Error Text  | Description   |
|-----------------------------|---|---|---|
| QMPC040                     | <input type="checkbox"/> Percentage range field<br><input type="checkbox"/> Search button | The specified lower value for Limit Utilisation is higher than the upper value for Limit Utilisation. | In case both the lower and upper value for Limit Utilisation are specified, the lower value for Limit Utilisation has to be lower than the upper value for Limit Utilisation. |

### 5.4.2.62 Limit Utilisation Journal - Search/List Screen

△ [▶ 352]

| Reference for error message | Field or Button  | Error Text   | Description  |
|-----------------------------|--|--|--|
| QMPC031                     | <input type="checkbox"/> T2S Dedicated Cash Account Number field<br><input type="checkbox"/> Search button | The specified T2S Dedicated Cash Account Number is not known in T2S. | In case a T2S Dedicated Cash Account Number is specified, it has to be known in T2S. |
| QMPC055                     | <input type="checkbox"/> Date field<br><input type="checkbox"/> Search button                              | The specified business date is in the future.                        | In case a business date is specified, it must not be in the future.                  |

### 5.4.2.63 Maintenance Cash Instructions – Search/List Screen

△ [▶ 447]

| Reference for error message | Field or Button  | Error Text   | Description  |
|-----------------------------|--|--|--|
| QMPC031                     | <input type="checkbox"/> Search button<br><input type="checkbox"/> n/a | The specified T2S Dedicated Cash Account Number is not known in T2S. | In case a T2S Dedicated Cash Account Number is specified, it has to be known in T2S. |

| Reference for error message | Field or Button   | Error Text  | Description   |
|-----------------------------|---|---|---|
| QMPC032                     | <input type="checkbox"/> Instructing Party BIC field<br><input type="checkbox"/> Search button  | The specified Party BIC is not known in T2S.                              | In case a Party BIC is specified, it has to be known in T2S.  |
| QMPC048                     | <input type="checkbox"/> Instructing Party Parent BIC field<br><input type="checkbox"/> Search button   | The specified Parent BIC is not known in T2S.                             | In case a Parent BIC is specified, it has to be known in T2S.   |
| QMPC084                     | <input type="checkbox"/> Instructing Party BIC field<br><input type="checkbox"/> Instructing Party Parent BIC field<br><input type="checkbox"/> Search button | The specified Parent BIC is not the System Entity of the specified party. | In case the BIC of a party as well as its parent BIC are specified, a party with these two BICs has to be known in T2S. |
| QMPC095                     | <input type="checkbox"/> n/a  | The entry date is after the current business date                         | In case the Entry Date To is stated, it must not be in the future.  |

#### 5.4.2.64 Maintenance Securities Instructions - Search/List Screen

△ [▶ 163]

| Reference for error message | Field or Button  | Error Text   | Description  |
|-----------------------------|--|--|--|
| QMPC016                     | <input type="checkbox"/> Execution Date field<br><input type="checkbox"/> Search button            | The Date From is older than three calendar months.           | The Date From must not be older than three calendar months.                  |
| QMPC030                     | <input type="checkbox"/> Securities Account Number field<br><input type="checkbox"/> Search button | The specified Securities Account Number is not known in T2S. | In case a Securities Account Number is specified, it has to be known in T2S. |
| QMPC032                     | <input type="checkbox"/> Instructing Party BIC field<br><input type="checkbox"/> Search button     | The specified Party BIC is not known in T2S.                 | In case a Party BIC is specified, it has to be known in T2S.                 |

| Reference for error message | Field or Button   | Error Text  | Description   |
|-----------------------------|---|---|---|
| QMPC048                     | <input type="checkbox"/> Instructing Party Parent BIC field<br><input type="checkbox"/> Search button   | The specified Parent BIC is not known in T2S.                             | In case a Parent BIC is specified, it has to be known in T2S.   |
| QMPC073                     | <input type="checkbox"/> Entry Date field<br><input type="checkbox"/> Execution Date field<br><input type="checkbox"/> Search button                          | The specified Date is in the future.                                      | In case a date from is specified, it must not be in the future.   |
| QMPC084                     | <input type="checkbox"/> Instructing Party BIC field<br><input type="checkbox"/> Instructing Party Parent BIC field<br><input type="checkbox"/> Search button | The specified Parent BIC is not the System Entity of the specified party. | In case the BIC of a party as well as its parent BIC are specified, a party with these two BICs has to be known in T2S. |

#### 5.4.2.65 Outbound File - Details Screen

△ [▶ 643]

| Reference for error message | Field or Button  | Error Text  | Description   |
|-----------------------------|--|---|---|
| IICR001                     | <input type="checkbox"/> Party Technical Address field<br><input type="checkbox"/> Resend button | At least one party technical address does not exist.                            | Resend communication is only possible for existing party technical addresses.   |
| IICR002                     | <input type="checkbox"/> Resend button   | The T2S System User is not authorized to ask for re-sending of a communication. | A T2S System User must have the appropriate privilege assigned with the requested secured object of type <party> to ask for re-sending a given communication. |

#### 5.4.2.66 Outbound Files - Search/List Screen

△ [▶ 640]

| Reference for error message | Field or Button  | Error Text  | Description   |
|-----------------------------|--|---|---|
| IICR001                     | <input type="checkbox"/> Party Technical Address field<br><input type="checkbox"/> Resend button   | At least one party technical address does not exist.                            | Resend communication is only possible for existing party technical addresses.   |
| IICR002                     | <input type="checkbox"/> Resend button   | The T2S System User is not authorized to ask for re-sending of a communication. | A T2S System User must have the appropriate privilege assigned with the requested secured object of type <party> to ask for re-sending a given communication. |
| QMPC015                     | <input type="checkbox"/> Delivery Date and Time from field<br><input type="checkbox"/> Delivery Date and Time to field<br><input type="checkbox"/> Search button | The Date From is after the Date To.   | In case the Date is stated as a range, the Date From has to be before or equal to the Date To.  |
| QMPC073                     | <input type="checkbox"/> Delivery Date and Time from field<br><input type="checkbox"/> Search button   | The specified Date is in the future.  | In case a date from is specified, it must not be in the future.   |

### 5.4.2.67 Outbound Message - Details Screen

△ [▶ 653]

| Reference for error message | Field or Button  | Error Text  | Description  |
|-----------------------------|--|---|--|
| IICR001                     | <input type="checkbox"/> Party Technical Address field<br><input type="checkbox"/> Resend button | At least one party technical address does not exist.                            | Resend communication is only possible for existing party technical addresses.                            |
| IICR002                     | <input type="checkbox"/> Resend button   | The T2S System User is not authorized to ask for re-sending of a communication. | A T2S System User must have the appropriate privilege assigned with the requested secured object of type |

| Reference for error message | Field or Button | Error Text | Description  |
|-----------------------------|-----------------|------------|--|
|                             |                 |            | <party> to ask for re-sending a given communication. |

### 5.4.2.68 Outbound Messages - Search/List Screen

△ [▶ 645]

| Reference for error message | Field or Button  | Error Text  | Description   |
|-----------------------------|--|---|---|
| IICR001                     | <input type="checkbox"/> Party Technical Address field<br><input type="checkbox"/> Resend button   | At least one party technical address does not exist.                            | Resend communication is only possible for existing party technical addresses.   |
| IICR002                     | <input type="checkbox"/> Resend button   | The T2S System User is not authorized to ask for re-sending of a communication. | A T2S System User must have the appropriate privilege assigned with the requested secured object of type <party> to ask for re-sending a given communication. |
| QMPC015                     | <input type="checkbox"/> Delivery Date and Time from field<br><input type="checkbox"/> Delivery Date and Time to field<br><input type="checkbox"/> Delivery Business Date from field<br><input type="checkbox"/> Delivery Business Date to field<br><input type="checkbox"/> Search button | The Date From is after the Date To.   | In case the Date is stated as a range, the Date From has to be before or equal to the Date To.  |

### 5.4.2.69 Outstanding Auto-Collateralisation Credits - Search/List Screen

△ [▶ 392]

| Reference for error message | Field or Button   | Error Text  | Description   |
|-----------------------------|---|---|---|
| QMPC031                     | <input type="checkbox"/> T2S Dedicated Cash Account Number field<br><input type="checkbox"/> Search button                      | The specified T2S Dedicated Cash Account Number is not known in T2S.      | In case a T2S Dedicated Cash Account Number is specified, it has to be known in T2S.                                    |
| QMPC084                     | <input type="checkbox"/> Party BIC field<br><input type="checkbox"/> Parent BIC field<br><input type="checkbox"/> Search button | The specified Parent BIC is not the System Entity of the specified party. | In case the BIC of a party as well as its parent BIC are specified, a party with these two BICs has to be known in T2S. |

### 5.4.2.70 Overall Liquidity - Search/List Screen

△ [▶ 396]

| Reference for error message | Field or Button   | Error Text  | Description   |
|-----------------------------|---|---|---|
| QMPC032                     | <input type="checkbox"/> Party BIC field<br><input type="checkbox"/> Search button  | The specified Party BIC is not known in T2S.                              | In case a Party BIC is specified, it has to be known in T2S.  |
| QMPC048                     | <input type="checkbox"/> Parent BIC field<br><input type="checkbox"/> Search button   | The specified Parent BIC is not known in T2S.                             | In case a Parent BIC is specified, it has to be known in T2S.   |
| QMPC084                     | <input type="checkbox"/> Party BIC field<br><input type="checkbox"/> Parent BIC field<br><input type="checkbox"/> Search button | The specified Parent BIC is not the System Entity of the specified party. | In case the BIC of a party as well as its parent BIC are specified, a party with these two BICs has to be known in T2S. |

### 5.4.2.71 Penalty - Details Screen

△ [▶ 290]

| Reference for error messages | Field or Button                     | Error Text   | Description   |
|------------------------------|-------------------------------------|--|---|
| PMMO010                      | <input type="checkbox"/> Re-include | Only failing CSD can request to modify a penalty   | Only the Failing CSD can request to modify a Penalty  |
| PMMO016                      | <input type="checkbox"/> Re-include | The removal, re-inclusion or switch does not refer to the individual penalty identification of the failing party | The removal, re-inclusion or switch must refer to the individual penalty identification of the failing party            |
| PMMO031                      | <input type="checkbox"/> Re-include | It is not possible to re-include a Penalty that is not removed   | The penalty provided in the re-inclusion request must have status Removed   |
| PMMO032                      | <input type="checkbox"/> Re-include | It is not possible to re-include a Penalty that was removed because of a Reallocation                            | The penalty provided in the re-inclusion request cannot be re-included if it has been removed because of a Reallocation |

### 5.4.2.72 Penalty - Re-allocation Screen

△ [▶ 317]

| Reference for error messages | Field or Button | Error Text   | Description  |
|------------------------------|-----------------|--|--|
| PMMO008                      | Submit          | The Request Type is 'RALO' and the requestor CSD is not the same as the CSD of the LMFP (CSD of the Instructing Party of the underlying instruction) | The request type is 'RALO' and the requestor CSD is not the same as the CSD of the Instructing Party of the underlying instruction |

| Reference for error messages | Field or Button   | Error Text   | Description  |
|------------------------------|---|--|--|
| PMMO021                      | New Failing Party BIC<br>Submit                               | The new failing Party is neither the delivering nor the receiving party of the underlying Settlement Instruction that was sent already matched   | The new failing Party must be either the delivering or the receiving party of the underlying Settlement Instruction that was sent already matched  |
| PMMO023                      | New Failing Party BIC<br>Submit                               | In case the New failing Party BIC corresponds to the delivering party of the underlying Settlement Instruction, the New non-failing Party BIC must correspond to the receiving party, and vice versa | In case the New failing Party BIC corresponds to the delivering party of the underlying Settlement Instruction, the New non-failing Party BIC must correspond to the receiving party, and vice versa |
| PMMO025                      | T2S reference of the Failing Settlement Instruction<br>Submit | The 'T2S reference of the failed Settlement Instruction' is neither the delivering nor the receiving Settlement Instruction created in T2S from the already matched                                  | The 'T2S reference of the failed Settlement Instruction' must be either the delivering or the receiving Settlement Instruction created in T2S  |
| PMMO033                      | Submit  | It is not possible to reallocate a Penalty that is not active  | The penalty provided in the reallocation request must have status Active   |



| Reference for error messages | Field or Button | Error Text  | Description   |
|------------------------------|-----------------|---|---|
| PMMO034                      | Submit          | It is not possible to reallocate a Penalty that is not a LMFP                               | The type of the penalty provided in the reallocation request must be LMFP   |
| PMMO035                      | Submit          | It is not possible to reallocate a Penalty already reallocated before                       | The penalty provided in the reallocation request cannot have been Reallocated before  |
| PMMO037                      | Submit          | The underlying Settlement Instruction of the Penalty was not sent as already matched to T2S | The underlying Settlement Instruction of the penalty provided in the reallocation request must be an instruction sent as already matched to T2S |

### 5.4.2.73 Penalty – Removal Screen

△ [▶ 314]

| Reference for error messages | Field or Button                 | Error Text   | Description  |
|------------------------------|---------------------------------|--|--|
| PMMO010                      | <input type="checkbox"/> Submit | Only failing CSD can request to modify a penalty   | Only the Failing CSD can request to modify a Penalty   |
| PMMO016                      | <input type="checkbox"/> Submit | The removal, re-inclusion or switch does not refer to the individual penalty identification of the failing party | The removal, re-inclusion or switch must refer to the individual penalty identification of the failing party |

| Reference for error messages | Field or Button                 | Error Text  | Description   |
|------------------------------|---------------------------------|---|---|
| PMMO030                      | <input type="checkbox"/> Submit | It is not possible to remove a Penalty that is not active | The penalty provided in the removal request must have status Active |

### 5.4.2.74 Penalty - Switch Screen

△ [▶ 321]

| Reference for error messages | Field or Button                 | Error Text   | Description  |
|------------------------------|---------------------------------|--|--|
| PMMO010                      | <input type="checkbox"/> Submit | Only failing CSD can request to modify a penalty   | Only the Failing CSD can request to modify a Penalty   |
| PMMO016                      | <input type="checkbox"/> Submit | The removal, re-inclusion or switch does not refer to the individual penalty identification of the failing party | The removal, re-inclusion or switch must refer to the individual penalty identification of the failing party |
| PMMO036                      | <input type="checkbox"/> Submit | It is not possible to switch a Penalty that is not active  | The penalty provided in the switch request must have status Active   |

### 5.4.2.75 Queued Static Data Change – Details Screen

△

No references for error messages.

### 5.4.2.76 Queued Static Data Changes – Search/List Screen

△

No references for error messages.

## 5.4.2.77 Resend Communication Screen

△ [▶ 657]

| Reference for error message | Field or Button   | Error Text  | Description  |
|-----------------------------|---|---|--|
| IICR001                     | <input type="checkbox"/> Party Technical Address field<br><input type="checkbox"/> Submit button  | At least one party technical address does not exist.  | Resend communication is only possible for existing party technical addresses.  |
| IICR002                     | <input type="checkbox"/> Submit button  | The T2S System User is not authorized to ask for re-sending of a communication.                   | A T2S System User must have the appropriate privilege assigned with the requested secured object of type <party> to ask for re-sending a given communication.                                      |
| IICR003                     | <input type="checkbox"/> Delivery Date field<br><input type="checkbox"/> Submit button  | The delivery date is no valid business date (current business date or in the past).               | The delivery date has to be a valid business date (current business date or in the past).  |
| IICR004                     | <input type="checkbox"/> Delivery Date field<br><input type="checkbox"/> Party Technical Address field<br><input type="checkbox"/> Single Sequence(s) field<br><input type="checkbox"/> Submit button | At least one sequence number mentioned in the specified selection criteria was not found.         | Resend communication on the basis of the message sequence is only possible, if the sequence number exists for the party technical address for the possibly mentioned delivery date (business day). |
| IICR004                     | <input type="checkbox"/> Delivery Date field<br><input type="checkbox"/> Party Technical Address field<br><input type="checkbox"/> Single Sequence(s) field<br><input type="checkbox"/> Submit button | No communication on the basis of the message sequence found for the specified selection criteria. | Resend communication on the basis of the message sequence is only possible, if the sequence number exists for the party technical address for the possibly mentioned delivery date (business day). |

| Reference for error message | Field or Button   | Error Text  | Description   |
|-----------------------------|---|---|---|
| IICR006                     | <input type="checkbox"/> Party Technical Address field<br><input type="checkbox"/> Delivery Date field<br><input type="checkbox"/> Sender File Reference field<br><input type="checkbox"/> Submit button    | No outbound file found for the specified selection criteria.  | Resend communication on the basis of the sender file reference is only possible, if the sender file reference exists for the party technical address for the possibly mentioned delivery date (business day).       |
| IICR007                     | <input type="checkbox"/> Party Technical Address field<br><input type="checkbox"/> Delivery Date field<br><input type="checkbox"/> Sender Message Reference field<br><input type="checkbox"/> Submit button | At least one sender message reference mentioned in the specified selection criteria was not found.        | Resend communication on the basis of the sender message reference is only possible, if the sender message reference exists for the party technical address for the possibly mentioned delivery date (business day). |
| IICR007                     | <input type="checkbox"/> Party Technical Address field<br><input type="checkbox"/> Delivery Date field<br><input type="checkbox"/> Sender Message Reference field<br><input type="checkbox"/> Submit button | No communication on the basis of the sender message reference found for the specified selection criteria. | Resend communication on the basis of the sender message reference is only possible, if the sender message reference exists for the party technical address for the possibly mentioned delivery date (business day). |

### 5.4.2.78 Revisions/Audit Trail - List Screen

△ [▶ 661]

No references for error messages.

### 5.4.2.79 Securities Position - Details Screen

△ [▶ 173]

No references for error messages.

## 5.4.2.80 Securities Positions - Search/List Screen

△ [▶ 168]

| Reference for error message | Field or Button   | Error Text   | Description  |
|-----------------------------|---|--|--|
| QMPC015                     | <input type="checkbox"/> Date from field<br><input type="checkbox"/> Date to field<br><input type="checkbox"/> Search button  | The Date From is after the Date To.  | In case the Date is stated as a range, the Date From has to be before or equal to the Date To  |
| QMPC016                     | <input type="checkbox"/> Date from field<br><input type="checkbox"/> Search button  | The Date From is older than three calendar months.   | The Date From must not be older than three calendar months.  |
| QMPC018                     | <input type="checkbox"/> ISIN field<br><input type="checkbox"/> Search button   | The specified ISIN is not known in T2S.  | In case an ISIN is specified, it has to be known in T2S.   |
| QMPC030                     | <input type="checkbox"/> Search button<br><input type="checkbox"/> Securities Account Number field  | The specified Securities Account Number is not known in T2S.   | In case a Securities Account Number is specified, it has to be known in T2S.   |
| QMPC032                     | <input type="checkbox"/> Party BIC field<br><input type="checkbox"/> Search button  | The specified Party BIC is not known in T2S.   | In case a Party BIC is specified, it has to be known in T2S.   |
| QMPC048                     | <input type="checkbox"/> Parent BIC field<br><input type="checkbox"/> Search button   | The specified Parent BIC is not known in T2S.  | In case a Parent BIC is specified, it has to be known in T2S.  |
| QMPC065                     | <input type="checkbox"/> Parent BIC field<br><input type="checkbox"/> Party BIC field<br><input type="checkbox"/> Search button<br><input type="checkbox"/> Securities Account Number field | The specified combination of selection parameters Securities Account Number, Account Owner and Account Servicer is not consistent. | In case several of the following selection criteria are specified, they have to be consistent, i. e. the securities account is owned by the account owning party and/or operated by the account servicing CSD; the party belongs to the CSD: |

| Reference for error message | Field or Button   | Error Text  | Description  |
|-----------------------------|---|---|--|
|                             |   |   | <ul style="list-style-type: none"> <li>• Securities Account Number</li> <li>• Account Owner</li> <li>• Account Servicer</li> </ul> |
| QMPC091                     | <input type="checkbox"/> Restriction Type field<br><input type="checkbox"/> Search button | The specified restriction type is not known in T2S. | In case a restriction type is specified, it has to be known in T2S.  |

### 5.4.2.81 Settlement Instruction - Details Screen

△ [▶ 191]

No references for error messages.

### 5.4.2.82 Settlement Instruction - New Screen

△ [▶ 210]

| Reference for error message | Field or Button   | Error Text  | Description  |
|-----------------------------|---|---|--|
| MVCA105                     | <input type="checkbox"/> Payment Type Code field<br><input type="checkbox"/> Externally Matched field<br><input type="checkbox"/> Currency field<br><input type="checkbox"/> T2S Dedicated Cash Account field<br><input type="checkbox"/> Submit button | The Currency of the Settlement Instruction is not the same as the Currency of the debited or credited T2S Dedicated Cash Account. | The Currency of a Settlement Instruction against payment must be the same as the Currency of the debited or credited T2S Dedicated Cash Account (both if it is an already matched Settlement Instruction). |
| MVCA501                     | <input type="checkbox"/> T2S Dedicated Cash Account Number field<br><input type="checkbox"/> Externally Matched field<br><input type="checkbox"/> Submit button   | The Credited T2S Dedicated Cash Account does not exist in T2S.  | The Credited T2S Dedicated Cash Account specified in unmatched Settlement Instruction crediting cash must exist in T2S.  |

| Reference for error message | Field or Button  | Error Text   | Description  |
|-----------------------------|--|--|--|
| MVCA502                     | <ul style="list-style-type: none"> <li><input type="checkbox"/> T2S Dedicated Cash Account Number field</li> <li><input type="checkbox"/> Externally Matched field</li> <li><input type="checkbox"/> Submit button</li> </ul>  | The Debited T2S Dedicated Cash Account does not exist in T2S.  | The Debited T2S Dedicated Cash Account specified in unmatched Settlement Instruction debiting cash must exist in T2S.  |
| MVCA503                     | <ul style="list-style-type: none"> <li><input type="checkbox"/> Payment Type Code field</li> <li><input type="checkbox"/> T2S Dedicated Cash Account Number field</li> <li><input type="checkbox"/> Externally Matched field</li> <li><input type="checkbox"/> Submit button</li> </ul>  | The Credited T2S Dedicated Cash Account does not exist in T2S.   | The Credited T2S Dedicated Cash Account and Debited T2S Dedicated Cash Account specified in an already matched Settlement Instruction against payment must exist in T2S.   |
| MVCA505                     | <ul style="list-style-type: none"> <li><input type="checkbox"/> Payment Type Code field</li> <li><input type="checkbox"/> T2S Dedicated Cash Account Number field</li> <li><input type="checkbox"/> Intended Settlement Date field</li> <li><input type="checkbox"/> Externally Matched field</li> <li><input type="checkbox"/> Submit button</li> </ul> | The Credited T2S Dedicated Cash Account is not open on the Settlement Date.  | The Credited T2S Dedicated Cash Account in unmatched Settlement Instruction crediting cash must be open on the Intended Settlement Date and additionally on the current Business Day if the Intended Settlement Date is in the past. |
| MVCA506                     | <ul style="list-style-type: none"> <li><input type="checkbox"/> T2S Dedicated Cash Account Number field</li> <li><input type="checkbox"/> Intended Settlement Date field</li> <li><input type="checkbox"/> Externally Matched field</li> <li><input type="checkbox"/> Submit button</li> </ul>   | The Debited T2S Dedicated Cash Account in an unmatched Settlement Instruction debiting cash is not open on the ISD and additionally on the current Business Day if the ISD is in the past. | The Debited T2S Dedicated Cash Account in unmatched Settlement Instruction debiting cash must be open on the Intended Settlement Date and additionally on the current  |

| Reference for error message | Field or Button  | Error Text  | Description   |
|-----------------------------|--|---|---|
|                             |  |   | Business Day if the Intended Settlement Date is in the past.  |
| MVCA507                     | <input type="checkbox"/> Payment Type Code field<br><input type="checkbox"/> T2S Dedicated Cash Account Number field<br><input type="checkbox"/> Intended Settlement Date field<br><input type="checkbox"/> Externally Matched field<br><input type="checkbox"/> Submit button     | The Credited T2S Dedicated Cash Account is not open on the Settlement Date.                                   | The Credited T2S Dedicated Cash Account and Debited T2S Dedicated Cash Account in an already matched Settlement Instruction against payment must be open on the Intended Settlement Date and additionally on the current Business Day if the Intended Settlement Date is in the past.                             |
| MVCA509                     | <input type="checkbox"/> Securities Account Number field<br><input type="checkbox"/> Dedicated Cash Account Number field<br><input type="checkbox"/> Intended Settlement Date field<br><input type="checkbox"/> Externally Matched field<br><input type="checkbox"/> Submit button | The Credited T2S Dedicated Cash Account is not associated with the Securities Account on the Settlement Date. | The Credited T2S Dedicated Cash Account specified in unmatched Settlement Instruction crediting cash must be associated in T2S with the Securities Account stated in the instruction on the Intended Settlement Date and additionally on the current Business Day if the Intended Settlement Date is in the past. |
| MVCA510                     | <input type="checkbox"/> Securities Account Number field   | The Debited T2S Dedicated Cash Account is not associated to the Securities                                    | The Debited T2S Dedicated Cash Account specified in unmatched Settlement  |



| Reference for error message | Field or Button  | Error Text  | Description   |
|-----------------------------|--|---|---|
|                             | <ul style="list-style-type: none"> <li><input type="checkbox"/> T2S Dedicated Cash Account Number field</li> <li><input type="checkbox"/> Intended Settlement Date field</li> <li><input type="checkbox"/> Externally Matched field</li> <li><input type="checkbox"/> Submit button</li> </ul>   | Account stated in the Instruction on the Settlement Date.   | Instruction debiting cash must be associated in T2S with the corresponding Securities Account stated in the instruction on the Intended Settlement Date and additionally on the current Business Day if the Intended Settlement Date is in the past.  |
| MVCA511                     | <ul style="list-style-type: none"> <li><input type="checkbox"/> Securities Account Number field</li> <li><input type="checkbox"/> Payment Type Code field</li> <li><input type="checkbox"/> T2S Dedicated Cash Account Number field</li> <li><input type="checkbox"/> Intended Settlement Date field</li> <li><input type="checkbox"/> Externally Matched field</li> <li><input type="checkbox"/> Submit button</li> </ul> | The Credited T2S Dedicated Cash Account is not associated with the Securities Account on the Settlement Date. | The Credited T2S Dedicated Cash Account and Debited T2S Dedicated Cash Account specified in an already matched Settlement Instruction against payment must be associated with the corresponding Securities Account stated in the instruction on the Intended Settlement Date and additionally on the current Business Day if the Intended Settlement Date is in the past. |
| MVCA514                     | <ul style="list-style-type: none"> <li><input type="checkbox"/> T2S Dedicated Cash Account Number field</li> <li><input type="checkbox"/> Settlement Amount field</li> <li><input type="checkbox"/> Externally Matched field</li> </ul>  | There is no default Credited T2S Dedicated Cash Account related to the Currency on the Settlement Date.       | If the Credited T2S Dedicated Cash Account is not specified in an unmatched Settlement Instruction crediting cash, there has to be in T2S a default Cash Account for  |

| Reference for error message | Field or Button   | Error Text  | Description  |
|-----------------------------|---|---|--|
|                             | <ul style="list-style-type: none"> <li><input type="checkbox"/> Submit button</li> </ul>  |   | the Currency of the cash leg of the Instruction on the Intended Settlement Date and additionally on the current Business Day if the Intended Settlement Date is in the past.   |
| MVCA515                     | <ul style="list-style-type: none"> <li><input type="checkbox"/> Dedicated Cash Account Number field</li> <li><input type="checkbox"/> Settlement Amount field</li> <li><input type="checkbox"/> Externally Matched field</li> <li><input type="checkbox"/> Submit button</li> </ul> | There is no default Debited T2S Dedicated Cash Account related to the Currency on the Settlement Date.  | If the Debited T2S Dedicated Cash Account is not specified in an unmatched Settlement Instruction debiting cash, there has to be a default Cash Account for the Currency of the cash leg specified in the Instruction on the Intended Settlement Date and additionally on the current Business Day if the Intended Settlement Date is in the past. |
| MVCA516                     | <ul style="list-style-type: none"> <li><input type="checkbox"/> Dedicated Cash Account Number field</li> <li><input type="checkbox"/> Settlement Amount field</li> <li><input type="checkbox"/> Externally Matched field</li> <li><input type="checkbox"/> Submit button</li> </ul> | There is no default Credited T2S Dedicated Cash Account related to the Currency on the Settlement Date. | If the Credited T2S Dedicated Cash Account and/or Debited T2S Dedicated Cash Account is/are not specified in an already matched Settlement Instruction against payment, there has to be in T2S a default Cash Account associated with the Currency   |

| Reference for error message | Field or Button  | Error Text  | Description   |
|-----------------------------|--|---|---|
|                             |  |   | of the cash leg of the Settlement Instruction on the Intended Settlement Date and additionally on the current Business Day if the Intended Settlement Date is in the past.                            |
| MVCA519                     | <input type="checkbox"/> T2S Dedicated Cash Account Number field<br><input type="checkbox"/> Debit Credit Indication field<br><input type="checkbox"/> Submit button | The debited T2S Dedicated Cash account of the Settlement Instruction is under an Insolvency restriction type  | The debited T2S Dedicated Cash Account specified in a Settlement Instruction must not have any Insolvency Restriction applicable for the current validation timestamp                                 |
| MVCP009                     | <input type="checkbox"/> Securities Account Number field<br><input type="checkbox"/> Submit button   | The sender of the Settlement Instruction is not authorised to send a Settlement Instruction on the Securities Account.                                  | The sender of a Settlement Instruction must be authorised to send a Settlement Instruction on a specific Securities Account.  |
| MVCP010                     | <input type="checkbox"/> Securities Account Number field<br><input type="checkbox"/> Externally Matched field<br><input type="checkbox"/> Submit button              | The sender of an Already Matched Settlement Instructions, is not authorised to send a Settlement Instruction on Securities Account of the counterparty. | For Already Matched Settlement Instructions, the sender of a Settlement Instruction must be authorised to send a Settlement Instruction on both the delivering and the receiving Securities Accounts. |
| MVCP011                     | <input type="checkbox"/> Receiving Depository BIC field<br><input type="checkbox"/> Delivery Depository BIC field<br><input type="checkbox"/> Submit button          | The sender of the Settlement Instruction is not authorised  | If the relevant Depository is an external CSD, the sender of a Settlement Instruction must be authorised to   |

| Reference for error message | Field or Button   | Error Text  | Description   |
|-----------------------------|---|---|---|
|                             |   | to send a Settlement Instruction on behalf of an external CSD.  | send a Settlement Instruction on behalf of that external CSD.   |
| MVCP012                     | <input type="checkbox"/> Allowed Modification Flag field<br><input type="checkbox"/> Submit button  | The sender of the Settlement Instruction is not authorised to send a Settlement Instruction with the non-modifiable flag activated. | If a Settlement Instruction has the Allowed Modification Flag activated, the sender of the Settlement Instruction must be authorised to send a Settlement Instruction with the non-modifiable flag activated. |
| MVCP013                     | <input type="checkbox"/> Link type field<br><input type="checkbox"/> Submit button  | The sender of the Settlement Instruction is not authorised to link to an instruction/pool belonging to another party.               | In case a Settlement Instruction intends to link to another instruction or pool, the sender of the Settlement Instruction must be authorised to link to an instruction/pool belonging to a specific party.    |
| MVCP036                     | <input type="checkbox"/> Securities Account Number field<br><input type="checkbox"/> Party Hold field<br><input type="checkbox"/> Submit button | The sender of a Settlement Instruction is not authorised to perform a Party Hold on the Securities Account.                         | The sender of a Settlement Instruction with a Party Hold activated must be authorised to perform a Party Hold on a specific Securities Account.   |
| MVCP037                     | <input type="checkbox"/> Securities Account Number field<br><input type="checkbox"/> CSD Hold field<br><input type="checkbox"/> Submit button   | The sender of a Settlement Instruction is not authorised to perform a CSD Hold on a specific Securities Account.                    | The sender of a Settlement Instruction with a CSD Hold activated must be authorised to perform a CSD Hold on a specific Securities Account.   |

| Reference for error message | Field or Button   | Error Text  | Description  |
|-----------------------------|---|---|--|
|                             |   |   | ised to perform a CSD Hold on a specific Securities Account.   |
| MVCP038                     | <input type="checkbox"/> Receiving Depository BIC field<br><input type="checkbox"/> Delivery Depository BIC field<br><input type="checkbox"/> CSD Hold field                              | The sender of a Settlement Instruction is not authorised to perform a CSD Hold on behalf of the parent CSD of the external CSD. | If the relevant Depository is an external CSD, the sender of a Settlement Instruction with a CSD Hold activated must be authorised to send a Settlement Instruction with CSD Hold on behalf of the parent CSD of the external CSD. |
| MVCP044                     | <input type="checkbox"/> Securities Account Number field<br><input type="checkbox"/> Securities Account field   | The Securities Account informed in the instruction does not exist in T2S.   | The Securities Account informed in the instruction must exist in T2S.  |
| MVCU101                     | <input type="checkbox"/> Currency field   | The Currency of the Settlement Instruction does not exist in T2S.   | The Currency of a Settlement Instruction must exist in T2S.  |
| MVCU103                     | <input type="checkbox"/> Payment Type Code field<br><input type="checkbox"/> Currency field<br><input type="checkbox"/> Submit button   | The Currency of the Settlement Instruction is not a T2S Settlement Currency.  | The Currency of a Settlement Instruction against payment must be a T2S Settlement Currency.  |
| MVCU107                     | <input type="checkbox"/> Payment Type Code field<br><input type="checkbox"/> Settlement Amount field<br><input type="checkbox"/> Currency field<br><input type="checkbox"/> Submit button | The number of decimals of the Settlement Amount of the Settlement Instruction exceeds the number of decimals defined in         | The number of decimals of the Settlement Amount of a Settlement Instruction against payment cannot exceed the number of decimals   |

| Reference for error message | Field or Button   | Error Text   | Description   |
|-----------------------------|---|--|---|
|                             |   | T2S for the Currency stated in the Settlement Instruction.                                     | defined in T2S for the Currency stated in the Settlement Instruction.   |
| MVCV001                     | <input type="checkbox"/> Securities Account field<br><input type="checkbox"/> Delivering Depository BIC field<br><input type="checkbox"/> Submit button   | The Delivering Securities Account does not exist in T2S.                                       | If the Delivering depository is an internal CSD, the delivering Securities Account specified in a securities Settlement Instruction must exist in T2S.      |
| MVCV002                     | <input type="checkbox"/> Receiving Depository BIC field<br><input type="checkbox"/> Securities Account field<br><input type="checkbox"/> Submit button  | The Receiving Securities Account does not exist in T2S.  | If the Receiving depository is an internal CSD, the receiving Securities Account specified in a securities Settlement Instruction must exist in T2S.        |
| MVCV003                     | <input type="checkbox"/> Externally Matched field<br><input type="checkbox"/> Securities Account field<br><input type="checkbox"/> Delivering Depository BIC field<br><input type="checkbox"/> Receiving Depository BIC field<br><input type="checkbox"/> Submit button | The Delivering or Receiving Securities Account does not exist in T2S.                          | In case of an already matched Settlement Instruction, when the Depository of the counterparty is in T2S, the relevant Securities Account must exist in T2S. |
| MVCV005                     | <input type="checkbox"/> Receiving CSD Participant Party BIC<br><input type="checkbox"/> Submit button  | The Party BIC of the Receiving CSD Participant is not specified in the Settlement Instruction. | The Party BIC of the Receiving Participant must be present in a receiving already matched cross-CSD settlement instructions                                 |
| MVCV006                     | <input type="checkbox"/> Receiving Depository BIC<br><input type="checkbox"/> Submit button   | The Receiving Depository BIC is not specified in the Settlement Instruction.                   | The Receiving Depository BIC must be present in a receiving   |

| Reference for error message | Field or Button  | Error Text  | Description  |
|-----------------------------|--|---|--|
|                             |  |   | already matched cross-CSD settlement instruction   |
| MVCV007                     | <input type="checkbox"/> Delivering CSD Participant Party BIC<br><input type="checkbox"/> Submit button  | The Party BIC of the Delivering CSD Participant is not specified in the Settlement Instruction.           | The Party BIC of the Delivering Participant must be present in a delivering already matched cross-CSD settlement instructions  |
| MVCV008                     | <input type="checkbox"/> Delivering Depository BIC<br><input type="checkbox"/> Submit button   | The Delivering Depository BIC is not specified in the Settlement Instruction.                             | The Delivering Depository BIC must be present in a delivering already matched cross-CSD settlement instruction   |
| MVCV106                     | <input type="checkbox"/> Intended Settlement Date field<br><input type="checkbox"/> Instructing Party BIC field<br><input type="checkbox"/> Instructing Party Parent BIC field<br><input type="checkbox"/> Submit button | The Instructing Party specified in the Settlement Instruction is not open on the settlement date.         | The Instructing Party specified in a Settlement Instruction must be open on the Intended Settlement Date and additionally on the current Business Day if the Intended Settlement Date is in the past.                                  |
| MVCV120                     | <input type="checkbox"/> Party BIC field<br><input type="checkbox"/> Delivering Depository BIC field<br><input type="checkbox"/> Intended Settlement Date field<br><input type="checkbox"/> Submit button                | The T2S Delivering Party BIC specified in the Settlement Instruction is not valid on the settlement date. | If the Delivering Depository specified in a Settlement Instruction is an external CSD, the T2S Delivering Party BIC indicated must be valid in T2S BIC Directory on the Intended Settlement Date and additionally on the current Busi- |

| Reference for error message | Field or Button   | Error Text  | Description  |
|-----------------------------|---|---|--|
|                             |   |   | ness Day if the Intended Settlement Date is in the past in T2S.  |
| MVCV121                     | <ul style="list-style-type: none"> <li><input type="checkbox"/> Party BIC field</li> <li><input type="checkbox"/> Intended Settlement Date field</li> </ul>   | The Client of Delivering CSD Participant BIC specified in the Settlement Instruction is not valid on the settlement date. | The Client of Delivering CSD participant BIC specified in the Settlement Instruction must be valid in T2S BIC Directory on the Intended Settlement Date and additionally on the current Business Day if the Intended Settlement Date is in the past in T2S.  |
| MVCV122                     | <ul style="list-style-type: none"> <li><input type="checkbox"/> Party BIC field</li> <li><input type="checkbox"/> Receiving Depository BIC field</li> <li><input type="checkbox"/> Submit button</li> </ul> | The T2S Receiving Party BIC specified in the Settlement Instruction is not valid on the settlement date.                  | If the Receiving Depository specified in a Settlement Instruction is an external CSD, the T2S Receiving Party BIC indicated must be valid in T2S BIC Directory on the Intended Settlement Date and additionally on the current Business Day if the Intended Settlement Date is in the past in T2S. |
| MVCV123                     | <ul style="list-style-type: none"> <li><input type="checkbox"/> Party BIC field</li> <li><input type="checkbox"/> Intended Settlement Date field</li> <li><input type="checkbox"/> Submit button</li> </ul> | The Client of Receiving CSD Participant BIC specified in the Settlement Instruction is not valid on the settlement date.  | The Client of Receiving CSD participant BIC specified in the Settlement Instruction must be valid in T2S BIC Directory on the Intended Settlement Date and additionally on the current Busi-   |



| Reference for error message | Field or Button  | Error Text   | Description   |
|-----------------------------|--|--|---|
|                             |  |  | ness Day if the Intended Settlement Date is in the past in T2S  |
| MVCV205                     | <input type="checkbox"/> ISIN field<br><input type="checkbox"/> Submit button  | The ISIN code indicated in the Settlement Instruction does not exist in T2S.   | The ISIN code indicated in a Settlement Instruction must exist in T2S   |
| MVCV229                     | <input type="checkbox"/> Instructing Party BIC field<br><input type="checkbox"/> Instructing Party Parent BIC field<br><input type="checkbox"/> Intended Settlement Date field<br><input type="checkbox"/> Submit button | The Instructing Party BIC or Parent BIC specified in the Settlement Instruction is not valid on the settlement date. | The Instructing Party BIC and Parent BIC indicated in a Settlement Instruction must be valid on the Intended Settlement Date and additionally on the current Business Day if the Intended Settlement Date is in the past. |
| MVCV234                     | <input type="checkbox"/> Intended Settlement Date field<br><input type="checkbox"/> Delivering Depository BIC field<br><input type="checkbox"/> Submit button  | The Delivering Depository specified in the Settlement Instruction is not open on the intended settlement date.       | The Delivering Depository in a Settlement Instruction must be open on the Intended Settlement Date and additionally on the current Business Day if the Intended Settlement Date is in the past.                           |
| MVCV235                     | <input type="checkbox"/> Intended Settlement Date field<br><input type="checkbox"/> Delivering Depository BIC field<br><input type="checkbox"/> Submit button  | The Delivering Depository BIC in the Settlement Instruction is not valid on the settlement date.                     | The Delivering Depository BIC in a Settlement Instruction must be valid on the Intended Settlement Date and additionally on the current Business Day  |

| Reference for error message | Field or Button  | Error Text  | Description   |
|-----------------------------|--|---|---|
|                             |  |   | if the Intended Settlement Date is in the past.   |
| MVCV236                     | <ul style="list-style-type: none"> <li><input type="checkbox"/> Delivering Depository BIC field</li> <li><input type="checkbox"/> Submit button</li> </ul>   | The Delivering Depository specified in the Settlement Instruction is not a CSD or an External CSD         | The Delivering Depository specified in a Settlement Instruction must be categorized in T2S as a CSD or as an External CSD.  |
| MVCV237                     | <ul style="list-style-type: none"> <li><input type="checkbox"/> Securities Movement Type Code field</li> <li><input type="checkbox"/> Delivering Depository BIC field</li> <li><input type="checkbox"/> Party BIC field</li> <li><input type="checkbox"/> Submit button</li> </ul> | The T2S Delivering Party is not specified in the Settlement Instruction.                                  | If the Delivering Depository specified in a delivering Settlement Instruction is an external CSD, the T2S Delivering Party must be specified in the Settlement Instruction. |
| MVCV238                     | <ul style="list-style-type: none"> <li><input type="checkbox"/> Delivering Depository BIC field</li> <li><input type="checkbox"/> Party BIC field</li> <li><input type="checkbox"/> Submit button</li> </ul>   | The T2S Delivering Party BIC specified in the Settlement Instruction does not exist in T2S BIC Directory. | If the Delivering Depository specified in a Settlement Instruction is an external CSD, the T2S Delivering Party BIC indicated must exist in T2S BIC Directory.              |
| MVCV239                     | <ul style="list-style-type: none"> <li><input type="checkbox"/> Delivering Depository BIC field</li> <li><input type="checkbox"/> Party BIC field</li> <li><input type="checkbox"/> Submit button</li> </ul>   | The T2S Delivering Party does not exist in T2S.   | If the Delivering Depository specified in a Settlement Instruction is an internal CSD, the T2S Delivering Party specified must exist in T2S                                 |
| MVCV241                     | <ul style="list-style-type: none"> <li><input type="checkbox"/> Intended Settlement Date field</li> <li><input type="checkbox"/> Delivering Depository BIC field</li> <li><input type="checkbox"/> Party BIC field</li> </ul>  | The T2S Delivering Party in the Settlement Instruction is not open on the settlement date.                | If the Delivering Depository in a Settlement Instruction is an internal CSD, the T2S Delivering Party must  |

| Reference for error message | Field or Button  | Error Text  | Description  |
|-----------------------------|--|---|--|
|                             | <ul style="list-style-type: none"> <li><input type="checkbox"/> Submit button</li> </ul>   |   | be open on the Intended Settlement Date and additionally on the current Business Day if the Intended Settlement Date is in the past.   |
| MVCV242                     | <ul style="list-style-type: none"> <li><input type="checkbox"/> Intended Settlement Date field</li> <li><input type="checkbox"/> Delivering Depository BIC field</li> <li><input type="checkbox"/> Party BIC field</li> <li><input type="checkbox"/> Submit button</li> </ul>      | The T2S Delivering Party BIC in the Settlement Instruction is not valid on the settlement date.                           | If the Delivering Depository in a Settlement Instruction is an internal CSD, the T2S Delivering Party BIC must be valid on the Intended Settlement Date and additionally on the current Business Day if the Intended Settlement Date is in the past. |
| MVCV243                     | <ul style="list-style-type: none"> <li><input type="checkbox"/> Securities Movement Type Code field</li> <li><input type="checkbox"/> Party BIC field</li> <li><input type="checkbox"/> Delivering Depository BIC field</li> <li><input type="checkbox"/> Submit button</li> </ul> | The Account Owner BIC and T2S Delivering Party BIC are not consistent.  | The Account Owner BIC and the T2S Delivering Party BIC specified in a delivering Settlement Instruction must be the same.  |
| MVCV244                     | <ul style="list-style-type: none"> <li><input type="checkbox"/> Party BIC field</li> <li><input type="checkbox"/> Submit button</li> </ul>   | The Client of Delivering CSD Participant BIC specified in the Settlement Instruction does not exist in T2S BIC Directory. | The Client of Delivering CSD participant BIC specified in the Settlement Instruction must exist in T2S BIC Directory.  |
| MVCV245                     | <ul style="list-style-type: none"> <li><input type="checkbox"/> Intended Settlement Date field</li> <li><input type="checkbox"/> Receiving Depository BIC field</li> </ul>   | The Receiving Depository in the Settlement Instruction is not open on the settlement date.                                | The Receiving Depository in a Settlement Instruction must be open on the Intended Settlement Date and  |

| Reference for error message | Field or Button   | Error Text   | Description   |
|-----------------------------|---|--|---|
|                             | <ul style="list-style-type: none"> <li><input type="checkbox"/> Submit button</li> </ul>  |  | additionally on the current Business Day if the Intended Settlement Date is in the past.  |
| MVCV246                     | <ul style="list-style-type: none"> <li><input type="checkbox"/> Intended Settlement Date field</li> <li><input type="checkbox"/> Receiving Depository BIC field</li> <li><input type="checkbox"/> Submit button</li> </ul>  | The Receiving Depository BIC in the Settlement Instruction is not valid on the settlement date.          | The Receiving Depository BIC in a Settlement Instruction must be valid on the Intended Settlement Date and additionally on the current Business Day if the Intended Settlement Date is in the past. |
| MVCV247                     | <ul style="list-style-type: none"> <li><input type="checkbox"/> Receiving Depository BIC field</li> <li><input type="checkbox"/> Submit button</li> </ul>   | The Receiving Depository specified in the Settlement Instruction is not a CSD or an External CSD         | The Receiving Depository specified in a Settlement Instruction must be categorized in T2S as a CSD or as an External CSD.   |
| MVCV248                     | <ul style="list-style-type: none"> <li><input type="checkbox"/> Securities Movement Type Code field</li> <li><input type="checkbox"/> Receiving Depository BIC field</li> <li><input type="checkbox"/> Party BIC field</li> <li><input type="checkbox"/> Submit button</li> </ul> | The T2S Receiving Party is not specified in the Settlement Instruction.                                  | If the Receiving Depository specified in a receiving Settlement Instruction is an external CSD, the T2S Receiving Party must be specified in the Settlement Instruction.                            |
| MVCV249                     | <ul style="list-style-type: none"> <li><input type="checkbox"/> Receiving Depository BIC field</li> <li><input type="checkbox"/> Party BIC field</li> <li><input type="checkbox"/> Submit button</li> </ul>   | The T2S Receiving Party BIC specified in the Settlement Instruction does not exist in T2S BIC Directory. | If the Receiving Depository specified in a Settlement Instruction is an external CSD, the T2S Receiving Party BIC indicated in  |

| Reference for error message | Field or Button   | Error Text   | Description  |
|-----------------------------|---|--|--|
|                             |   |  | a Settlement Instruction must exist in T2S BIC Directory.  |
| MVCV250                     | <input type="checkbox"/> Receiving Depository BIC field<br><input type="checkbox"/> Party BIC field<br><input type="checkbox"/> Submit button   | The T2S Receiving Party does not exist in T2S.   | If the Receiving Depository specified in a Settlement Instruction is an internal CSD, the T2S Receiving Party specified must exist in T2S  |
| MVCV251                     | <input type="checkbox"/> Intended Settlement Date field<br><input type="checkbox"/> Receiving Depository BIC field<br><input type="checkbox"/> BIC field<br><input type="checkbox"/> Securities Account field | The T2S Receiving Party in the Settlement Instruction is not open on the settlement date.      | If the Receiving Depository in a Settlement Instruction is an internal CSD, the T2S Receiving Party must be open on the Intended Settlement Date and additionally on the current Business Day if the Intended Settlement Date is in the past.      |
| MVCV252                     | <input type="checkbox"/> Intended Settlement Date field<br><input type="checkbox"/> Receiving Depository BIC field<br><input type="checkbox"/> BIC field<br><input type="checkbox"/> Submit button            | The T2S Receiving Party BIC in the Settlement Instruction is not valid on the settlement date. | If the Receiving Depository in a Settlement Instruction is an internal CSD, the T2S Receiving Party BIC must be valid on the Intended Settlement Date and additionally on the current Business Day if the Intended Settlement Date is in the past. |

| Reference for error message | Field or Button   | Error Text   | Description  |
|-----------------------------|---|--|--|
| MVCV253                     | <input type="checkbox"/> Securities Movement Type Code field<br><input type="checkbox"/> Party BIC field<br><input type="checkbox"/> Securities Account Owner BIC field<br><input type="checkbox"/> Submit button | The Account Owner BIC and T2S Receiving Party BIC are not consistent.  | The Account Owner BIC and the T2S Receiving Party BIC specified in a receiving Settlement Instruction must be the same.  |
| MVCV254                     | <input type="checkbox"/> Party BIC field  | The Client of Receiving CSD Participant BIC specified in the Settlement Instruction does not exist in T2S BIC Directory. | The Client of Receiving CSD participant BIC specified in the Settlement Instruction must exist in T2S BIC Directory.   |
| MVCV256                     | <input type="checkbox"/> Debit Credit Indicator field<br><input type="checkbox"/> T2S Dedicated Cash Account Number field<br><input type="checkbox"/> Submit button   | The Dedicated Cash Account is not consistent with the Debtor Cash Account.   | The Dedicated cash account and Debtor cash account must be the same if both are present in Settlement Instruction debiting cash.   |
| MVCV257                     | <input type="checkbox"/> Debit Credit Indicator field<br><input type="checkbox"/> T2S Dedicated Cash Account Number field<br><input type="checkbox"/> Submit button   | The Dedicated Cash Account is not consistent with the Creditor Cash Account.   | The Dedicated Cash Account and Creditor cash account must be the same if both are present in a Settlement Instruction crediting cash.  |
| MVCV271                     | <input type="checkbox"/> Securities Movement Type Code field<br><input type="checkbox"/> Securities Account Number field<br><input type="checkbox"/> Securities Account field                                     | The Delivering Securities Account is not consistent with the Securities Account of the T2S Delivering Party.             | The Delivering Securities Account of a delivering Settlement Instruction must be the same than the Securities Account of the T2S Delivering Party if this latter is present in the Settlement Instruction. |

| Reference for error message | Field or Button  | Error Text   | Description   |
|-----------------------------|--|--|---|
|                             | <input type="checkbox"/> Submit button   |  |   |
| MVCV272                     | <input type="checkbox"/> Securities Movement Type Code field<br><input type="checkbox"/> Securities Account Number field<br><input type="checkbox"/> Securities Account field<br><input type="checkbox"/> Submit button  | The Receiving Securities Account is not consistent with the Securities Account of the T2S Receiving Party. | The Receiving Securities Account of a receiving Settlement Instruction must be the same than the Securities Account of the T2S Receiving Party if this latter is present in the Settlement Instruction.   |
| MVCV273                     | <input type="checkbox"/> Securities Account Number field<br><input type="checkbox"/> Intended Settlement Date field<br><input type="checkbox"/> Securities Account field<br><input type="checkbox"/> Delivering Depository BIC field<br><input type="checkbox"/> Submit button | The Delivering Securities Account is not open on the settlement date.                                      | If the Delivering depository is an internal CSD the delivering Securities Account specified in a Settlement Instruction must be open on the Intended Settlement Date and additionally on the current Business Day if the Intended Settlement Date is in the past. |
| MVCV274                     | <input type="checkbox"/> Securities Account Number field<br><input type="checkbox"/> Securities Account field<br><input type="checkbox"/> Intended Settlement Date field<br><input type="checkbox"/> Receiving Depository BIC field<br><input type="checkbox"/> Submit button  | The Receiving Securities Account is not open on the settlement date.                                       | If the Receiving depository is an internal CSD the receiving Securities Account specified in a Settlement Instruction must be open on the Intended Settlement Date and additionally on the current Business Day if the Intended Settlement Date is in the past.   |

| Reference for error message | Field or Button   | Error Text   | Description  |
|-----------------------------|---|--|--|
| MVCV275                     | <ul style="list-style-type: none"> <li><input type="checkbox"/> Securities Account Number field</li> <li><input type="checkbox"/> Intended Settlement Date field</li> <li><input type="checkbox"/> Externally Matched field</li> <li><input type="checkbox"/> Securities Account field</li> <li><input type="checkbox"/> Submit button</li> </ul> | The Securities Account of the counterparty in an already matched instruction is not open on the settlement date. | In case of an already matched Settlement Instruction, when the Depository of the counterparty is in T2S, the relevant Securities Account must be open on the Intended Settlement Date and additionally on the current Business Day if the Intended Settlement Date is in the past. |
| MVCV276                     | <ul style="list-style-type: none"> <li><input type="checkbox"/> Securities Account Number field</li> <li><input type="checkbox"/> Securities Account field</li> <li><input type="checkbox"/> Delivering Depository BIC field</li> <li><input type="checkbox"/> Submit button</li> </ul>   | The Delivering Depository is not consistent with the depository of the securities account.                       | If the Delivering Depository specified in a securities Settlement Instruction is internal to T2S, the Delivering Depository must be the same than the depository derived from the delivering securities account in T2S Static Data.  |
| MVCV277                     | <ul style="list-style-type: none"> <li><input type="checkbox"/> Securities Account Number field</li> <li><input type="checkbox"/> Securities Account field</li> <li><input type="checkbox"/> Receiving Depository BIC field</li> <li><input type="checkbox"/> Submit button</li> </ul>  | The Receiving Depository is not consistent with the depository of the securities account.                        | If the Receiving Depository specified in a securities Settlement Instruction is internal to T2S, the Receiving Depository must be the same than the depository derived from the receiving securities account in T2S Static Data.   |
| MVCV278                     | <ul style="list-style-type: none"> <li><input type="checkbox"/> Securities Account Number field</li> </ul>  | The Depository of the counterparty in an already matched   | In case of an already matched Settlement Instruction, when the   |



| Reference for error message | Field or Button   | Error Text  | Description   |
|-----------------------------|---|---|---|
|                             | <input type="checkbox"/> Externally Matched field<br><input type="checkbox"/> Delivering Depository BIC field<br><input type="checkbox"/> Receiving Depository BIC field<br><input type="checkbox"/> Submit button  | instruction is not consistent with the depository of the corresponding securities account.                | Depository of the counterparty is in T2S and it is specified, it must be the same than the depository derived from the relevant securities account in T2S Static Data.  |
| MVCV279                     | <input type="checkbox"/> Securities Movement Type Code field<br><input type="checkbox"/> Securities Account Number field<br><input type="checkbox"/> Delivering Depository BIC field<br><input type="checkbox"/> Securities Account Owner BIC field<br><input type="checkbox"/> Submit button                                   | The Account Owner specified is not consistent with the owner of the delivering securities account.        | If the Delivering Depository is internal to T2S, the Account Owner BIC derived from the delivering securities account in T2S Static Data must be the same than the Account Owner BIC if it is present in a delivering Settlement Instruction. |
| MVCV280                     | <input type="checkbox"/> Securities Movement Type Code field<br><input type="checkbox"/> Securities Account Number field<br><input type="checkbox"/> Party BIC field<br><input type="checkbox"/> Securities Account field<br><input type="checkbox"/> Delivering Depository BIC field<br><input type="checkbox"/> Submit button | The T2S Delivering Party specified is not consistent with the owner of the delivering securities account. | If the Delivering Depository is internal to T2S, the Account Owner BIC derived from the delivering securities account in T2S Static Data must be the same than the T2S Delivering Party BIC if it is present in a Settlement Instruction.     |
| MVCV281                     | <input type="checkbox"/> Securities Movement Type Code field  | The Account Owner specified is not consistent with the  | If the Receiving Depository is internal to T2S, the Account   |

| Reference for error message | Field or Button  | Error Text  | Description  |
|-----------------------------|--|---|--|
|                             | <ul style="list-style-type: none"> <li><input type="checkbox"/> Securities Account Number field</li> <li><input type="checkbox"/> Securities Account field</li> <li><input type="checkbox"/> Receiving Depository BIC field</li> <li><input type="checkbox"/> Securities Account Owner BIC field</li> <li><input type="checkbox"/> Submit button</li> </ul>  | owner of the receiving securities account.  | Owner derived from the receiving securities account in T2S Static Data must be the same than the Account Owner if it is present in a receiving Settlement Instruction.   |
| MVCV282                     | <ul style="list-style-type: none"> <li><input type="checkbox"/> Securities Movement Type Code field</li> <li><input type="checkbox"/> Securities Account Number field</li> <li><input type="checkbox"/> Receiving Depository BIC field</li> <li><input type="checkbox"/> Party BIC field</li> <li><input type="checkbox"/> Securities Account field</li> <li><input type="checkbox"/> Submit button</li> </ul> | The T2S Receiving Party specified is not consistent with the owner of the receiving securities account.                             | If the Receiving Depository is internal to T2S, the Account Owner derived from the receiving securities account in T2S Static Data must be the same than the T2S Receiving Party if it is present in a Settlement Instruction.   |
| MVCV283                     | <ul style="list-style-type: none"> <li><input type="checkbox"/> Externally Matched field</li> <li><input type="checkbox"/> Party BIC field</li> <li><input type="checkbox"/> Delivering Depository BIC field</li> <li><input type="checkbox"/> Receiving Depository BIC field</li> <li><input type="checkbox"/> Submit button</li> </ul>   | The T2S Delivering Party or T2S Receiving Party specified is not consistent with the owner of the corresponding securities account. | In case of an already matched Settlement Instruction, when the Depository of the counterparty is in T2S and it is specified, the Account Owner BIC derived from the counterpart securities account in T2S Static Data must be the same than the counterpart T2S Party BIC. |

| Reference for error message | Field or Button   | Error Text   | Description  |
|-----------------------------|---|--|--|
| MVCV286                     | <ul style="list-style-type: none"> <li><input type="checkbox"/> Settlement Quantity field</li> <li><input type="checkbox"/> Settlement Type field</li> <li><input type="checkbox"/> Settlement Amount field</li> <li><input type="checkbox"/> Submit button</li> </ul>  | The Settlement Amount and Settlement Quantity are zero.  | Either the Settlement Amount or Settlement Quantity of a Settlement Instruction must be greater than zero.   |
| MVCV287                     | <ul style="list-style-type: none"> <li><input type="checkbox"/> Securities Movement Type Code field</li> <li><input type="checkbox"/> Delivering Depository BIC field</li> <li><input type="checkbox"/> Instructing Party BIC field</li> <li><input type="checkbox"/> Instructing Party Parent BIC field</li> <li><input type="checkbox"/> Submit button</li> </ul> | The CSD of the Instructing Party is not consistent with the Delivering Depository of the Settlement Instruction.                         | In a delivering Settlement Instruction the CSD of the Instructing Party must be consistent with the Delivering CSD.  |
| MVCV288                     | <ul style="list-style-type: none"> <li><input type="checkbox"/> Securities Movement Type Code field</li> <li><input type="checkbox"/> Instructing Party BIC field</li> <li><input type="checkbox"/> Instructing Party Parent BIC field</li> <li><input type="checkbox"/> Receiving Depository BIC field</li> <li><input type="checkbox"/> Submit button</li> </ul>  | The CSD of the Instructing Party is not consistent with the Receiving Depository of the Settlement Instruction.                          | In a receiving Settlement Instruction the CSD of the Instructing Party must be consistent with the Receiving CSD.  |
| MVCV289                     | <ul style="list-style-type: none"> <li><input type="checkbox"/> Externally Matched field</li> <li><input type="checkbox"/> Delivering Depository BIC field</li> <li><input type="checkbox"/> Instructing Party BIC field</li> </ul>   | The CSD of the Instructing Party is not consistent with the Delivering Depository or Receiving Depository of the Settlement Instruction. | In case of an already matched Settlement Instruction, the CSD of the Instructing Party must be consistent with either the Receiving or the Delivering CSD. |

| Reference for error message | Field or Button   | Error Text  | Description   |
|-----------------------------|---|---|---|
|                             | <ul style="list-style-type: none"> <li><input type="checkbox"/> Instructing Party Parent BIC field</li> <li><input type="checkbox"/> Receiving Depository BIC field</li> <li><input type="checkbox"/> Submit button</li> </ul>  |   |   |
| MVCV298                     | <ul style="list-style-type: none"> <li><input type="checkbox"/> Delivering Depository BIC field</li> <li><input type="checkbox"/> ISIN field</li> <li><input type="checkbox"/> Securities Movement Type Code field</li> <li><input type="checkbox"/> Submit button</li> </ul> | The Security CSD Links does not allow to identify the relevant external CSD for Delivering Depository and ISIN specified in the instruction.    | If the Delivering Depository specified in a receiving Settlement Instruction is defined by different parent CSDs as an external CSD, the Security CSD Links must allow to identify the relevant external CSD for the ISIN of the instruction. |
| MVCV299                     | <ul style="list-style-type: none"> <li><input type="checkbox"/> ISIN field</li> <li><input type="checkbox"/> Receiving Depository BIC field</li> <li><input type="checkbox"/> Securities Movement Type Code field</li> <li><input type="checkbox"/> Submit button</li> </ul>  | The Security CSD Links does not allow to identify the relevant external CSD for the Receiving Depository and ISIN specified in the instruction. | If the Receiving Depository specified in a delivering Settlement Instruction is defined by different parent CSDs as an external CSD, the Security CSD Links must allow to identify the relevant external CSD for the ISIN of the instruction. |
| MVCV301                     | <ul style="list-style-type: none"> <li><input type="checkbox"/> ISIN field</li> <li><input type="checkbox"/> Intended Settlement Date field</li> <li><input type="checkbox"/> Submit button</li> </ul>  | The ISIN code indicated in the Settlement Instruction is not valid on the settlement date   | The ISIN code indicated in a Settlement Instruction must be valid on the Intended Settlement Date and additionally on the current Business Day if the Intended Settlement Date is in the past.  |

| Reference for error message | Field or Button  | Error Text  | Description  |
|-----------------------------|--|---|--|
| MVCV303                     | <input type="checkbox"/> ISIN field<br><input type="checkbox"/> Intended Settlement Date field<br><input type="checkbox"/> Submit button   | The ISIN Code of the Settlement Instruction is not active on the Settlement Date.                                   | The ISIN Code indicated in a Settlement Instruction must be active on the Intended Settlement Date and additionally on the current Business Day if the Intended Settlement Date is in the past.                                      |
| MVCV305                     | <input type="checkbox"/> Securities Account Number field<br><input type="checkbox"/> Securities Account field<br><input type="checkbox"/> Securities Movement Type Code field<br><input type="checkbox"/> Submit button    | The delivering securities account of the instruction is under an Insolvency restriction type                        | The delivering Securities Account specified in delivering securities Settlement Instruction must not have any Insolvency Restriction applicable for the current validation timestamp   |
| MVDC002                     | <input type="checkbox"/> Transaction Identification field<br><input type="checkbox"/> Instructing Party BIC field<br><input type="checkbox"/> Instructing Party Parent BIC field<br><input type="checkbox"/> Submit button | An unsettled Settlement Instruction exists in T2S for the same T2S Party and the same instruction reference.        | The combination of the Instruction Reference and the Instructing Party of a Settlement Instruction must not be the same as any of the non-cancelled and non-revoked unsettled Settlement Instructions already present in the system. |
| MVDC004                     | <input type="checkbox"/> Transaction Identification field<br><input type="checkbox"/> Instructing Party BIC field  | A Settlement Instruction that has been settled within a predefined number of days in the past already exists in T2S | The combination of the Instruction Reference and the Instructing Party of a Settlement Instruction must not be the same as   |

| Reference for error message | Field or Button  | Error Text   | Description   |
|-----------------------------|--|--|---|
|                             | <ul style="list-style-type: none"> <li><input type="checkbox"/> Instructing Party Parent BIC field</li> <li><input type="checkbox"/> Submit button</li> </ul>  | for the same T2S Party and the same instruction reference.   | any Settlement Instruction present in the system that has been settled within a predefined number of days in the past.  |
| MVDC006                     | <ul style="list-style-type: none"> <li><input type="checkbox"/> Transaction Identification field</li> <li><input type="checkbox"/> Instructing Party BIC field</li> <li><input type="checkbox"/> Instructing Party Parent BIC field</li> <li><input type="checkbox"/> Submit button</li> </ul> | A Settlement Instruction that has been cancelled within a predefined number of days in the past already exists in T2S for the same T2S Party and the same instruction reference. | The combination of the Instruction Reference and the Instructing Party of a Settlement Instruction must not be the same as any Settlement Instruction present in the system that has been cancelled within a predefined number of days in the past. |
| MVDC014                     | <ul style="list-style-type: none"> <li><input type="checkbox"/> Transaction Identification field</li> <li><input type="checkbox"/> Instructing Party BIC field</li> <li><input type="checkbox"/> Instructing Party Parent BIC field</li> <li><input type="checkbox"/> Submit button</li> </ul> | An unsettled Settlement Restriction exists in T2S for the same T2S Party and the same instruction reference.   | The combination of the Instruction Reference and the Instructing Party of a Settlement Instruction must not be the same as any of the non-cancelled and non-revoked unsettled Settlement Restriction already present in the system.                 |
| MVDC016                     | <ul style="list-style-type: none"> <li><input type="checkbox"/> Transaction Identification field</li> <li><input type="checkbox"/> Instructing Party BIC field</li> <li><input type="checkbox"/> Instructing Party Parent BIC field</li> <li><input type="checkbox"/> Submit button</li> </ul> | A Settlement Restriction that has been settled within a predefined number of days in the past already exists in T2S  | The combination of the Instruction Reference and the Instructing Party of a Settlement Instruction must not be the same as any Settlement Restriction present in the  |

| Reference for error message | Field or Button  | Error Text   | Description  |
|-----------------------------|--|--|--|
|                             |  | for the same T2S Party and the same instruction reference.   | system that has been settled within a pre-defined number of days in the past.  |
| MVDC018                     | <ul style="list-style-type: none"> <li><input type="checkbox"/> Transaction Identification field</li> <li><input type="checkbox"/> Instructing Party BIC field</li> <li><input type="checkbox"/> Instructing Party Parent BIC field</li> <li><input type="checkbox"/> Submit button</li> </ul> | A Settlement Restriction that has been cancelled within a predefined number of days in the past already exists in T2S for the same T2S Party and the same instruction reference. | The combination of the Instruction Reference and the Instructing Party of a Settlement Instruction must not be the same as any Settlement Restriction present in the system that has been cancelled within a pre-defined number of days in the past. |
| MVDC020                     | <ul style="list-style-type: none"> <li><input type="checkbox"/> Transaction Identification field</li> </ul>  | A Partially Settled Settlement Instruction exists in T2S for the same T2S Party and the same instruction reference.  | The combination of the Instruction Reference and the Instructing Party of a Settlement Instruction must not be the same as any of the non-cancelled Partially Settled Settlement Instructions already present in the system.                         |
| MVDC021                     | <ul style="list-style-type: none"> <li><input type="checkbox"/> Transaction Identification field</li> <li><input type="checkbox"/> Instructing Party BIC field</li> <li><input type="checkbox"/> Instructing Party Parent BIC field</li> <li><input type="checkbox"/> Submit button</li> </ul> | A Partially Settled Settlement Restriction exists in T2S for the same T2S Party and the same instruction reference.  | The combination of the Instruction Reference and the Instructing Party of a Settlement Instruction must not be the same as any of the non-cancelled Partially Settled Settlement Restriction already present in the system.                          |

| Reference for error message | Field or Button   | Error Text   | Description  |
|-----------------------------|---|--|--|
| MVDC024                     | <input type="checkbox"/> Instructing Party BIC field<br><input type="checkbox"/> Instructing Party Parent BIC field<br><input type="checkbox"/> Submit button   | The Instructing Party specified in the Settlement Instruction does not exist in T2S Static Data.   | The Instructing Party specified in a Settlement Instruction must exist in T2S Static Data.   |
| MVIC305                     | <input type="checkbox"/> ISIN field<br><input type="checkbox"/> Intended Settlement Date field<br><input type="checkbox"/> Receiving Depository BIC field<br><input type="checkbox"/> Delivering Depository BIC field<br><input type="checkbox"/> Submit button | The ISIN Code of the Settlement Instruction is not eligible for settlement in the delivering CSD.  | The ISIN Code of a delivering Settlement Instruction must be eligible for settlement in the delivering CSD on the Intended Settlement Date and additionally on the current Business Day if the Intended Settlement Date is in the past.  |
| MVIC307                     | <input type="checkbox"/> ISIN field<br><input type="checkbox"/> Receiving Depository BIC field<br><input type="checkbox"/> Delivering Depository BIC field<br><input type="checkbox"/> Intended Settlement Date field<br><input type="checkbox"/> Submit button | The CSD of the T2S Party does not allow settlement with the counterpart for the ISIN Code on the ISD and additionally on the current Business Day if the ISD is in the past. | The CSD of the T2S Party of a Settlement Instruction must allow settlement with the CSD of the counterpart for the ISIN Code (either per security or per issuer CSD or per issue country) on the Intended Settlement Date and additionally on the current Business Day if the Intended Settlement Date is in the past. |
| MVIC308                     | <input type="checkbox"/> ISIN field<br><input type="checkbox"/> Receiving Depository BIC field<br><input type="checkbox"/> Delivering Depository BIC field  | The CSD of the counterpart does not allow settlement with the CSD of the T2S Party for the ISIN Code on the ISD and  | The CSD of the counterpart of a Settlement Instruction must allow settlement with the CSD of the T2S Party for the ISIN Code   |



| Reference for error message | Field or Button  | Error Text  | Description  |
|-----------------------------|--|---|--|
|                             | <ul style="list-style-type: none"> <li><input type="checkbox"/> Intended Settlement Date field</li> <li><input type="checkbox"/> Submit button</li> </ul>  | additionally on the current Business Day if the ISD is in the past.   | (either per security or per issuer CSD or per issue country) on the Intended Settlement Date and additionally on the current Business Day if the Intended Settlement Date is in the past.  |
| MVIC309                     | <ul style="list-style-type: none"> <li><input type="checkbox"/> Intended Settlement Date field</li> <li><input type="checkbox"/> Instructing Party BIC field</li> <li><input type="checkbox"/> Instructing Party Parent BIC field</li> <li><input type="checkbox"/> Submit button</li> </ul> | The Issue Date of the Security is later than the Intended Settlement Date of the Settlement Instruction.  | When the Instructing Party is not the technical Issuer CSD or the Issuer CSD of the ISIN Code specified in a Settlement Instruction, the Intended Settlement Date of a Settlement Instruction must be equal to or later than the Issue Date of the Security.   |
| MVIC311                     | <ul style="list-style-type: none"> <li><input type="checkbox"/> ISIN field</li> <li><input type="checkbox"/> Intended Settlement Date field</li> <li><input type="checkbox"/> Submit button</li> </ul>   | The Maturity Date of the Security plus the transformation detection period is earlier or equal than the Intended Settlement Date of the Settlement Instruction. | When the Instructing Party is not the investor CSD, the technical Issuer CSD or the Issuer CSD of the ISIN Code specified in a Settlement Instruction, the Intended Settlement Date of a Settlement Instruction must be earlier than the Maturity Date of the Security plus the transformation detection period. |

| Reference for error message | Field or Button  | Error Text   | Description  |
|-----------------------------|--|--|--|
| MVIC313                     | <input type="checkbox"/> ISIN field<br><input type="checkbox"/> Instructing Party BIC field<br><input type="checkbox"/> Instructing Party Parent BIC field<br><input type="checkbox"/> Submit button | The Maturity Date of the Security plus the transformation detection period is earlier or equal than the Current Business Date. | When the Instructing Party is not the investor CSD, the technical Issuer CSD or the Issuer CSD of the ISIN Code specified in a Settlement Instruction, the Current Business Date must be earlier than the Maturity Date of the ISIN code plus the transformation detection period. |
| MVLI801                     | <input type="checkbox"/> Link Type field<br><input type="checkbox"/> Submit button   | The instruction has a Settlement link indicator 'WITH' and the existing Linked Instruction is already settled.                 | The Settlement Status of a Settlement Instruction or Settlement Restriction stated as linked instruction with Link Processing Position 'WITH' in a Settlement Instruction must not be 'Settled'.   |
| MVLI802                     | <input type="checkbox"/> Link Type field<br><input type="checkbox"/> Submit button   | The instruction has a Settlement link indicator 'WITH' and the existing Linked Instruction is already cancelled.               | The Cancellation Status of a Settlement Instruction or Settlement Restriction stated as linked instruction with Link Processing Position 'WITH' in a Settlement Instruction must not be 'Cancelled'.   |
| MVLI803                     | <input type="checkbox"/> Link Type field<br><input type="checkbox"/> Submit button   | The instruction has a Settlement link indicator 'BEFORE' and   | The Settlement Status of a Settlement Instruction or Settlement Restriction stated as linked instruction with  |

| Reference for error message | Field or Button   | Error Text  | Description   |
|-----------------------------|---|---|---|
|                             |   | the existing linked Settlement instruction is already settled   | Link Processing Position 'BEFORE' in a Settlement Instruction must not be 'Settled'.  |
| MVLI813                     | <input type="checkbox"/> Intended Settlement Date field<br><input type="checkbox"/> Link Type field<br><input type="checkbox"/> Submit button | The instruction has a Settlement link indicator 'WITH' and the Settlement link indicator included in the existing linked instruction is 'BEFORE'. | If a Settlement Instruction states a link 'WITH' with a Settlement Instruction or a Settlement Restriction, these latter must not have a previous link 'BEFORE' with the Settlement Instruction unless they have the same Intended Settlement Date.         |
| MVLI814                     | <input type="checkbox"/> Intended Settlement Date field<br><input type="checkbox"/> Link Type field<br><input type="checkbox"/> Submit button | The instruction has a Settlement link indicator 'WITH' and the Settlement link indicator included in the existing linked instruction is 'AFTER'.  | A Settlement Instruction or Settlement Restriction stated as linked 'WITH' in a Settlement Instruction must not have a previous link 'AFTER' with the latter instruction, provided that the Intended Settlement Date in both instructions is not identical. |
| MVLI815                     | <input type="checkbox"/> Intended Settlement Date field<br><input type="checkbox"/> Link Type field<br><input type="checkbox"/> Submit button | The instruction has a Settlement link indicator 'AFTER' and the Settlement link indicator included in the existing linked instruction is 'AFTER'. | A Settlement Instruction or Settlement Restriction stated as linked 'AFTER' in a Settlement Instruction must not have a previous link 'AFTER' with the latter instruction, provided that the In-  |

| Reference for error message | Field or Button   | Error Text  | Description  |
|-----------------------------|---|---|--|
|                             |   |   | tended Settlement Date in both instructions is not identical.  |
| MVLI816                     | <ul style="list-style-type: none"> <li><input type="checkbox"/> Intended Settlement Date field</li> <li><input type="checkbox"/> Link Type field</li> <li><input type="checkbox"/> Submit button</li> </ul> | The instruction has a Settlement link indicator 'AFTER' and the Settlement link indicator included in the existing linked instruction is 'WITH'.    | A Settlement Instruction or Settlement Restriction stated as linked 'AFTER' in a Settlement Instruction must not have a previous link 'WITH' with the latter instruction, provided that the Intended Settlement Date in both instructions is not identical.    |
| MVLI817                     | <ul style="list-style-type: none"> <li><input type="checkbox"/> Intended Settlement Date field</li> <li><input type="checkbox"/> Link Type field</li> <li><input type="checkbox"/> Submit button</li> </ul> | The instruction has a Settlement link indicator 'BEFORE' and the Settlement link indicator included in the existing linked instruction is 'BEFORE'. | A Settlement Instruction or Settlement Restriction stated as linked 'BEFORE' in a Settlement Instruction must not have a previous link 'BEFORE' with the latter instruction, provided that the Intended Settlement Date in both instructions is not identical. |
| MVLI818                     | <ul style="list-style-type: none"> <li><input type="checkbox"/> Intended Settlement Date field</li> <li><input type="checkbox"/> Link Type field</li> <li><input type="checkbox"/> Submit button</li> </ul> | The instruction has a Settlement link indicator 'BEFORE' and the Settlement link indicator included in the existing linked instruction is 'WITH'.   | A Settlement Instruction or Settlement Restriction stated as linked 'BEFORE' in a Settlement Instruction must not have a previous link 'WITH' with the latter instruction, provided that the In-   |

| Reference for error message | Field or Button  | Error Text  | Description   |
|-----------------------------|--|---|---|
|                             |  |   | tended Settlement Date in both instructions is not identical.   |
| MVLI831                     | <input type="checkbox"/> Intended Settlement Date field<br><input type="checkbox"/> Link Type field<br><input type="checkbox"/> Submit button  | The instruction has a Settlement link indicator 'BEFORE' and the linked instruction's Intended Settlement Date is earlier than the validating instruction's Intended Settlement Date. | The Intended Settlement Date of a Settlement Instruction must be equal to or earlier than the Intended Settlement Date of the Settlement Instruction or Settlement Restriction linked with the first one, if the Link Indicator is 'BEFORE'.            |
| MVLI832                     | <input type="checkbox"/> Intended Settlement Date field<br><input type="checkbox"/> Link Type field<br><input type="checkbox"/> Submit button  | The instruction has a Settlement link indicator 'AFTER' and the linked instruction's Intended Settlement Date is later than the validating instruction's Intended Settlement Date.    | The Intended Settlement Date of a Settlement Instruction must be equal to or later than the Intended Settlement Date of the Settlement Instruction or Settlement Restriction linked with the first one, if the Link Indicator is 'AFTER'.               |
| MVLI833                     | <input type="checkbox"/> Intended Settlement Date field<br><input type="checkbox"/> Link Type field<br><input type="checkbox"/> Pool Instruction Reference field<br><input type="checkbox"/> Submit button | The instruction has either a Settlement link indicator 'WITH' or a pool reference and the linked instruction's Intended Settlement Date is different.                                 | The Intended Settlement Date of a Settlement Instruction must be equal to the Intended Settlement Date of the Settlement Instruction or Settlement Restriction linked with the first one, if the Link Indicator is 'WITH' or in case of Pool reference. |

| Reference for error message | Field or Button   | Error Text  | Description  |
|-----------------------------|---|---|--|
| MVLI843                     | <input type="checkbox"/> Pool Instruction Counter field<br><input type="checkbox"/> Submit button   | The number of instructions belonging to a Pool must be the same that the Linked Instruction Counter of the Settlement Instruction or Settlement Restriction | The value of the Pool Instruction Counter stated in a Settlement Instruction, must be the same as the value of the Pool Instruction Counter for such a Pool in T2S, if any instruction belonging to that Pool is already present in T2S. |
| MVLI845                     | <input type="checkbox"/> Pool Instruction Counter field<br><input type="checkbox"/> Submit button   | The instruction exceeds the number of instructions of the pool.   | The number of instructions that have already been identified in T2S as belonging to the Pool Reference stated in a Settlement Instruction must be lower than the Pool Instruction Counter stated in that Settlement Instruction          |
| MVLI847                     | <input type="checkbox"/> Pool Instruction Reference field<br><input type="checkbox"/> Submit button | The instruction includes more than one Pool Reference or more than one link referring to the same instruction.  | A Settlement Instruction must not include more than one Pool Reference or more than one link referring to the same instruction.  |
| MVLI851                     | <input type="checkbox"/> Link Type field<br><input type="checkbox"/> Submit button                  | The instruction has a Settlement link indicator 'WITH' and the existing Linked Instruction is already partially settled.                                    | The Settlement Status of a Settlement Instruction or Settlement Restriction stated as linked instruction with Link Processing Position 'WITH' in a Settle-   |

| Reference for error message | Field or Button  | Error Text   | Description   |
|-----------------------------|--|--|---|
|                             |  |  | ment Instruction must not be 'Partially Settled'  |
| MVLI854                     | <input type="checkbox"/> Link Type field<br><input type="checkbox"/> Submit button | The instruction has a Settlement link indicator 'BEFORE' and the existing Linked Instruction is already partially settled. | The Settlement Status of a Settlement Instruction or Settlement Restriction stated as linked instruction with Link Processing Position 'BEFORE' in a Settlement Instruction must not be 'Partially Settled' |
| MVLI857                     | <input type="checkbox"/> Link Type field<br><input type="checkbox"/> Submit button | The instruction has a Settlement link indicator 'AFTER' and the existing Linked Instruction is already partially settled.  | The Settlement Status of a Settlement Instruction or Settlement Restriction stated as linked instruction with Link Processing Position 'AFTER' in a Settlement Instruction must not be 'Partially Settled'  |
| MVLI860                     | <input type="checkbox"/> Link Type field<br><input type="checkbox"/> Submit button | The instruction has a Settlement link indicator 'AFTER' and the existing Linked Instruction is already cancelled           | The Settlement Status of a Settlement Instruction or Settlement Restriction stated as linked instruction with Link Processing Position 'AFTER' in a Settlement Instruction must not be 'Cancelled'          |
| MVLI863                     | <input type="checkbox"/> Link Type field<br><input type="checkbox"/> Submit button | The Linked Instruction is 'Revoked'.   | The Approval Status of a Settlement Instruction or Settlement Restriction stated as   |

| Reference for error message | Field or Button  | Error Text   | Description  |
|-----------------------------|--|--|--|
|                             |  |  | linked instruction with Link Processing Position 'WITH' in a Settlement Instruction must not be 'Revoked'  |
| MVLI865                     | <input type="checkbox"/> Link Type field<br><input type="checkbox"/> Submit button   | The Linked Instruction is 'Revoked'.   | The Approval Status of a Settlement Instruction or Settlement Restriction stated as linked instruction with Link Processing Position 'AFTER' in a Settlement Instruction must not be 'Revoked'                                     |
| MVLI868                     | <input type="checkbox"/> Pool Instruction Reference field<br><input type="checkbox"/> Instructing Party BIC field<br><input type="checkbox"/> Instructing Party Parent BIC field<br><input type="checkbox"/> Submit button | A Pool that has been settled within a pre-defined number of days in the past already exists in T2S for the same T2S Party and the same Pool Identification | The combination of the Pool Identification and the Instructing Party of a Pool must not be the same as any Pool Identification already present in the system that has been settled within a pre-defined number of days in the past |
| MVRR926                     | <input type="checkbox"/> Cash Sub Balance Type<br><input type="checkbox"/> Submit button   | The Cash Sub Balance Type specified in the Settlement Instruction is not Deliverable Type.   | The Restriction Type specified in the Cash Sub Balance Type in a Settlement Instruction can only be 'Deliverable'.   |
| MVRR929                     | <input type="checkbox"/> Securities Movement Type Code field<br><input type="checkbox"/> Receiving Securities Sub Balance Type   | If a Settlement Instruction specifies the Receiving Securities Sub Balance Type, it cannot be a  | If the Receiving Securities Sub Balance Type is specified in a Settlement Instruction,   |



| Reference for error message | Field or Button   | Error Text  | Description  |
|-----------------------------|---|---|--|
|                             | <input type="checkbox"/> Submit button  | blocking or reservation securities position.  | it must not be a restriction type of Blocking or Reservation   |
| MVRR934                     | <input type="checkbox"/> Restriction Reference field<br><input type="checkbox"/> Submit button  | The Restriction Reference specified in the Settlement Restriction does not apply on blocked or reserved securities position                     | The Restriction Reference specified in a Settlement Instruction for the use of a restricted securities position must be related to a Blocked or Reserved securities position.  |
| MVRR935                     | <input type="checkbox"/> Restriction Reference field<br><input type="checkbox"/> Submit button  | The Restriction Reference specified in the Settlement Instruction does not exist in T2S.  | The Restriction Reference specified in a Settlement Instruction for the use of a restricted cash balance must exist in T2S.  |
| MVRR936                     | <input type="checkbox"/> Restriction Reference field<br><input type="checkbox"/> Submit button  | The Restriction Reference specified in the Settlement Instruction is not related to a Blocked or Reserved cash balance.                         | The Restriction Reference specified in a Settlement Instruction for the use of a restricted cash balance must be related to a Blocked or Reserved cash balance.  |
| MVRR937                     | <input type="checkbox"/> Delivering Securities Sub Balance Type<br><input type="checkbox"/> Restriction Reference field<br><input type="checkbox"/> Submit button | A Restriction Reference related to securities is not specified in the Settlement Instruction which makes use of a Blocked or Reserved position. | If a Settlement Instruction makes use thru direct debit of a Blocked or Reserved restricted position, a Restriction Reference related to securities must be specified. (I.e. If the Restriction Type specified in the Delivering Securities Sub Balance Type in a Set- |

| Reference for error message | Field or Button  | Error Text   | Description   |
|-----------------------------|--|--|---|
|                             |  |  | tlement Instruction is 'Blocking' or 'Reservation' a Restriction Reference must be specified).  |
| MVRR941                     | <ul style="list-style-type: none"> <li><input type="checkbox"/> Securities Movement Type Code field</li> <li><input type="checkbox"/> Restriction Reference field</li> <li><input type="checkbox"/> Cash Sub Balance Type field</li> <li><input type="checkbox"/> Payment Type Code field</li> <li><input type="checkbox"/> Submit button</li> </ul> | The Settlement Instruction is Free of Payment and makes use of a restricted cash balance.  | A Settlement Instruction Free of Payment cannot make use of a restricted cash balance.  |
| MVRR942                     | <ul style="list-style-type: none"> <li><input type="checkbox"/> Securities Movement Type Code field</li> <li><input type="checkbox"/> Delivering Securities Sub Balance Type</li> <li><input type="checkbox"/> Restriction Reference field</li> <li><input type="checkbox"/> Submit button</li> </ul>  | The Free of Delivering Settlement Instruction tries to make use of a restricted securities position.   | A Free of Delivery Settlement Instruction cannot make use of a restricted securities position (i.e. A Free of Delivery Settlement Instruction cannot specify a Restriction Reference neither a Restriction type related to securities). |
| MVRR944                     | <ul style="list-style-type: none"> <li><input type="checkbox"/> Securities Account Number field</li> <li><input type="checkbox"/> Restriction Reference field</li> <li><input type="checkbox"/> Submit button</li> </ul>   | The delivering securities account of the Settlement Instruction is different than the securities account inferred from the Restriction Reference | If a Settlement Instruction makes use of a restricted position specifying the Restriction Reference, the securities account associated with the Restriction Reference must be the same than the securit-                                |

| Reference for error message | Field or Button  | Error Text   | Description  |
|-----------------------------|--|--|--|
|                             |  |  | ies account specified in the Settlement Instruction.   |
| MVRR945                     | <input type="checkbox"/> Restriction Reference field<br><input type="checkbox"/> ISIN field<br><input type="checkbox"/> Submit button                              | The security of the Settlement Instruction is different than the security inferred from the Restriction Reference.   | If a Settlement Instruction makes use of a restricted position specifying the Restriction Reference, the security associated with the Restriction Reference must be the same than the security specified in the Settlement Instruction.  |
| MVRR947                     | <input type="checkbox"/> T2S Dedicated Cash Account Number field<br><input type="checkbox"/> Restriction Reference field<br><input type="checkbox"/> Submit button | The T2S dedicated cash account specified or default cash account of the Settlement Instruction is different than the cash account inferred from the Restriction Reference. | If a Settlement Instruction makes use of a restricted cash balance specifying the Restriction Reference, the T2S Dedicated Cash Account associated with the Restriction Reference must be the same than the T2S dedicated Cash Account specified in the Settlement Instruction or the default T2S dedicated Cash Account if not present in the Settlement Instruction. |
| MVRR948                     | <input type="checkbox"/> Delivering Securities Sub Balance Type  | A Settlement Instruction cannot make use of a CoSD Blocking or Collateralized position.  | A Settlement Instruction cannot make use of CoSD blocking or Collateralized positions. (I.e. The Restriction Type specified in   |

| Reference for error message | Field or Button   | Error Text  | Description   |
|-----------------------------|---|---|---|
|                             | <ul style="list-style-type: none"> <li><input type="checkbox"/> Receiving Securities Sub Balance Type</li> <li><input type="checkbox"/> Submit button</li> </ul>  |   | either the Delivering or the Receiving Securities Sub Balance Type in a Settlement Instruction cannot be 'CoSD blocking' or 'Collateralized'  |
| MVRR951                     | <ul style="list-style-type: none"> <li><input type="checkbox"/> Restriction Reference field</li> <li><input type="checkbox"/> Submit button</li> </ul>  | The Restriction Reference related to cash is specified in a crediting cash Settlement Instruction         | If a Settlement Instruction specifies a Restriction Reference related to cash, the Settlement Instruction must be debiting cash.  |
| MVRR957                     | <ul style="list-style-type: none"> <li><input type="checkbox"/> Intended Settlement Date field</li> <li><input type="checkbox"/> Cash Sub Balance Type</li> <li><input type="checkbox"/> Submit button</li> </ul> | The Cash Sub Balance Type specified in the Settlement Instruction is not valid on the Settlement Date.    | The Restriction Type specified in the Cash Sub Balance Type in a Settlement Instruction must be valid on the Intended Settlement Date or on the current Business Date if the Intended Settlement Date is in the past. |
| MVRR958                     | <ul style="list-style-type: none"> <li><input type="checkbox"/> Cash Sub Balance Type</li> <li><input type="checkbox"/> Submit button</li> </ul>  | The Cash Sub Balance Type specified in the Settlement Instruction does not apply on cash balance.         | The Restriction Type specified in the Cash Sub Balance Type in a Settlement Instruction must be applicable on cash balance in T2S.  |
| MVRR959                     | <ul style="list-style-type: none"> <li><input type="checkbox"/> Delivering Securities Sub Balance Type</li> <li><input type="checkbox"/> Submit button</li> </ul>   | The Delivering Securities Sub Balance Type specified in the Settlement Instruction does not exist in T2S. | If the Delivering Securities Sub Balance Type is specified in a Settlement Instruction, it must exist as a Restriction Type in T2S.   |

| Reference for error message | Field or Button  | Error Text  | Description   |
|-----------------------------|--|---|---|
| MVRR960                     | <ul style="list-style-type: none"> <li><input type="checkbox"/> Intended Settlement Date field</li> <li><input type="checkbox"/> Delivering Securities Sub Balance Type</li> <li><input type="checkbox"/> Submit button</li> </ul> | The Delivering Securities Sub Balance Type specified in the Settlement Instruction is not valid on the Settlement Date.   | The Restriction Type specified in the Delivering Securities Sub Balance Type in a Settlement Instruction must be valid on the Intended Settlement Date and additionally on the current Business Date if the Intended Settlement Date is in the past.            |
| MVRR961                     | <ul style="list-style-type: none"> <li><input type="checkbox"/> Delivering Securities Sub Balance Type</li> <li><input type="checkbox"/> Submit button</li> </ul>  | The Delivering Securities Sub Balance Type specified in the Settlement Instruction does not apply on securities position. | The Restriction Type specified in the Delivering Securities Sub Balance Type in a Settlement Instruction must be applicable on securities position in T2S.  |
| MVRR962                     | <ul style="list-style-type: none"> <li><input type="checkbox"/> Receiving Securities Sub Balance Type</li> <li><input type="checkbox"/> Submit button</li> </ul>   | The Receiving Securities Sub Balance Type specified in the Settlement Instruction does not exist in T2S.                  | If the Receiving Securities Sub Balance Type is specified in a Settlement Instruction, it must exist as a Restriction Type in T2S.  |
| MVRR963                     | <ul style="list-style-type: none"> <li><input type="checkbox"/> Delivering Securities Sub Balance Type</li> <li><input type="checkbox"/> Restriction Reference field</li> <li><input type="checkbox"/> Submit button</li> </ul>    | The Restriction Reference specified in the Settlement Instruction does not apply on blocked securities position.          | If a Settlement Instruction makes use thru direct debit of a Blocked restricted position, the Restriction Reference specified must be related to a blocked securities position in T2S. (I.e. If the Restriction Type specified in the Delivering Securities Sub |

| Reference for error message | Field or Button   | Error Text   | Description   |
|-----------------------------|---|--|---|
|                             |   |  | Balance Type in a Settlement Instruction is 'Blocking', a Restriction Reference must be related to a blocked securities position in T2S).   |
| MVRR964                     | <ul style="list-style-type: none"> <li><input type="checkbox"/> Delivering Securities Sub Balance Type</li> <li><input type="checkbox"/> Restriction Reference field</li> <li><input type="checkbox"/> Submit button</li> </ul> | The Restriction Reference specified in the Settlement Instruction does not apply on reserved securities position.        | If a Settlement Instruction makes use thru direct debit of a Reserved restricted position, the Restriction Reference specified must be related to reserved securities position in T2S. (I.e. If the Restriction Type specified in the Delivering Securities Sub Balance Type in a Settlement Instruction is 'Reservation', a Restriction Reference must be related to a reserved securities position in T2S). |
| MVRR965                     | <ul style="list-style-type: none"> <li><input type="checkbox"/> Receiving Securities Sub Balance Type</li> <li><input type="checkbox"/> Submit button</li> </ul>  | The Receiving Securities Sub Balance Type specified in the Settlement Instruction does not apply on securities position. | The Restriction Type specified in the Receiving Securities Sub Balance Type in a Settlement Instruction must be applicable on securities position in T2S.   |
| MVRR972                     | <ul style="list-style-type: none"> <li><input type="checkbox"/> Receiving Securities Sub Balance Type</li> </ul>  | The Receiving Securities Sub Balance Type specified in the   | The Restriction Type specified in the Receiving Securities Sub Balance Type in a Set-   |

| Reference for error message | Field or Button   | Error Text   | Description   |
|-----------------------------|---|--|---|
|                             | <ul style="list-style-type: none"> <li><input type="checkbox"/> Submit button</li> </ul>  | Settlement Instruction is not valid on the Settlement Date.  | tlement Instruction must be valid on the Intended Settlement Date and additionally on the current Business Date if the Intended Settlement Date is in the past.   |
| MVRR984                     | <ul style="list-style-type: none"> <li><input type="checkbox"/> Receiving Securities Sub Balance Type</li> <li><input type="checkbox"/> Restriction Reference field</li> <li><input type="checkbox"/> Submit button</li> </ul>  | The Restriction Reference related to securities is specified in the receiving securities Settlement Instruction.                     | A receiving securities Settlement Instruction can set up or increase an 'Earmarking' or 'Earmarking for auto collateralization securities position', therefore the Restriction Reference must not be specified in the Settlement Instruction.               |
| MVRR986                     | <ul style="list-style-type: none"> <li><input type="checkbox"/> Delivering Securities Sub Balance Type</li> <li><input type="checkbox"/> Restriction Reference field</li> <li><input type="checkbox"/> Submit button</li> </ul> | The Restriction Type associated to the Restriction Reference is different than the Restriction Type of the Settlement Instruction.   | If a Settlement Instruction makes use thru direct debit of a Blocked restricted position, the Restriction Type associated with the Restriction Reference must be the same than the Delivering Securities Sub Balance specify in the Settlement Instruction. |
| MVRR987                     | <ul style="list-style-type: none"> <li><input type="checkbox"/> Delivering Securities Sub Balance Type</li> <li><input type="checkbox"/> Restriction Reference field</li> <li><input type="checkbox"/> Submit button</li> </ul> | The Restriction Type associated with the Restriction Reference is different than the Restriction Type of the Settlement Instruction. | If a Settlement Instruction makes use thru direct debit of a Reserved restricted position, the Restriction Type associated with the Restriction Refer-  |

| Reference for error message | Field or Button   | Error Text   | Description   |
|-----------------------------|---|--|---|
|                             |   |  | ence must be the same than the Delivering Securities Sub Balance specify in the Settlement Instruction.   |
| MVRR988                     | <input type="checkbox"/> Cash Sub Balance Type field  | The Cash Sub Balance Type specified in the Settlement Instruction does not exist in T2S.   | If the Cash Sub Balance Type is specified in a Settlement Instruction, it must exist as a Restriction Type in T2S.  |
| MVSD401                     | <input type="checkbox"/> Intended Settlement Date field<br><input type="checkbox"/> Trade Date field<br><input type="checkbox"/> Submit button  | The Trade Date is later than the Intended Settlement Date of the Settlement Instruction.   | The Trade Date of a Settlement Instruction has to be equal to or earlier than its Intended Settlement Date.   |
| MVSD403                     | <input type="checkbox"/> Payment Type Code field<br><input type="checkbox"/> Settlement Amount field<br><input type="checkbox"/> Intended Settlement Date field<br><input type="checkbox"/> Submit button | The Intended Settlement Date of the Settlement Instruction against payment is not a T2S Settlement Date for the Settlement Currency. | The Intended Settlement Date of a Settlement Instruction against payment must be a T2S Settlement Date for the Settlement Currency of the Settlement Instruction. |
| MVSD406                     | <input type="checkbox"/> Payment Type Code field<br><input type="checkbox"/> Intended Settlement Date field<br><input type="checkbox"/> Submit button   | The Intended Settlement Date of the Settlement Instruction free of payment is Saturday, Sunday or a Closing Day in T2S.              | The Intended Settlement Date of a Settlement Instruction free of payment must be a day from Monday to Friday and a Business Date in T2S                           |
| MVSD411                     | <input type="checkbox"/> Intended Settlement Date field<br><input type="checkbox"/> Submit button   | The Intended Settlement Date of the instruction exceeds the predefined time frame for past-dated instructions                        | If the Intended Settlement Date of an instruction is a date in the past, the Intended Settlement Date must not exceed the pre-                                    |



| Reference for error message | Field or Button   | Error Text   | Description  |
|-----------------------------|---|--|--|
|                             |   |  | defined time frame for past-dated instructions.  |
| MVSD412                     | <input type="checkbox"/> Intended Settlement Date field<br><input type="checkbox"/> Submit button   | The Intended Settlement Date of the instruction exceeds the predefined time frame for future-dated instructions                    | If the Intended Settlement Date of an instruction is a date in the future, the Intended Settlement Date must not exceed the predefined time frame for future-dated instructions.   |
| MVSP208                     | <input type="checkbox"/> Priority field<br><input type="checkbox"/> Submit button   | 'Reserved priority' not allowed for the Instructing Party Type (only CSDs can use it)  | 'Reserved priority' is allowed in a Settlement Instruction only if the Instructing Party is a CSD  |
| MVSP602                     | <input type="checkbox"/> ISIN field<br><input type="checkbox"/> Settlement Quantity field<br><input type="checkbox"/> Securities Transaction Type field<br><input type="checkbox"/> Submit button | The Settlement Quantity stated in the instruction is not expressed using the same Settlement Type specified in T2S Reference Data. | The Settlement Quantity stated in a Settlement Instruction with exchange of Securities must be expressed using the same Settlement Type as the one specified in T2S Reference Data for the ISIN Code of the Instruction. |
| MVSP604                     | <input type="checkbox"/> ISIN field<br><input type="checkbox"/> Settlement Quantity field<br><input type="checkbox"/> Settlement Type field<br><input type="checkbox"/> Submit button             | The Settlement Quantity of the Settlement Instruction is lower than the Minimum Settlement Unit                                    | The Settlement Quantity specified in a Settlement Instruction with exchange of securities and not related to a 'Corporate Action', 'Market Claim' or 'Transformation', must be equal or greater                          |

| Reference for error message | Field or Button   | Error Text   | Description  |
|-----------------------------|---|--|--|
|                             |   |  | than the Minimum Settlement Unit specified in T2S.   |
| MVSQ606                     | <input type="checkbox"/> ISIN field<br><input type="checkbox"/> Settlement Quantity field<br><input type="checkbox"/> Settlement Transaction Type field<br><input type="checkbox"/> Submit button<br><input type="checkbox"/> n/a | The Settlement Quantity of the Settlement Instruction is neither a multiple of Settlement Unit Multiple nor a Deviating Settlement Unit.           | The Settlement Quantity of a Settlement Instruction with exchange of securities and not related to a 'Corporate Action', 'Market Claim' or 'Transformation', must be a multiple of the Settlement Unit Multiple or a Deviating Settlement Unit.  |
| MVSQ610                     | <input type="checkbox"/> Settlement Quantity field<br><input type="checkbox"/> Settlement Transaction Type field<br><input type="checkbox"/> Submit button<br><input type="checkbox"/> n/a  | The remaining Settlement Quantity of the Settlement Instruction is neither a multiple of Settlement Unit Multiple nor a Deviating Settlement Unit. | In case of a partially settled Settlement Instruction with exchange of securities and not related to a 'Corporate Action', 'Market Claim' or 'Transformation', the remaining Settlement Quantity must be a multiple unit of the Settlement Unit Multiple or a Deviating Settlement Unit. |
| MVIC315                     | <input type="checkbox"/> ISIN field<br><input type="checkbox"/> Intended Settlement Date field<br><input type="checkbox"/> Securities Account Number field  | The ISIN Code of the Settlement Instruction is not eligible for settlement in the receiving CSD.   | The ISIN Code of a receiving Settlement Instruction must be eligible for settlement in the receiving CSD on the Intended Settlement Date and additionally on the current   |

| Reference for error message | Field or Button  | Error Text   | Description  |
|-----------------------------|--|--|--|
|                             | <ul style="list-style-type: none"> <li><input type="checkbox"/> Securities Movement Type Code field</li> <li><input type="checkbox"/> Receiving Depository BIC field</li> <li><input type="checkbox"/> Submit button</li> </ul>  |  | Business Day if the Intended Settlement Date is in the past.   |
| MVIC316                     | <ul style="list-style-type: none"> <li><input type="checkbox"/> ISIN field</li> <li><input type="checkbox"/> Delivering Depository BIC field</li> <li><input type="checkbox"/> Externally Matched field</li> <li><input type="checkbox"/> Intended Settlement Date field</li> <li><input type="checkbox"/> Receiving Depository BIC field</li> <li><input type="checkbox"/> Securities Movement Type Code field</li> <li><input type="checkbox"/> Submit button</li> </ul> | The ISIN Code of the already matched Settlement Instruction is not eligible for settlement in the delivering or receiving CSD. | The ISIN Code of an already matched Settlement Instruction must be eligible for settlement in the delivering and receiving CSD on the Intended Settlement Date and additionally on the current Business Day if the Intended Settlement Date is in the past.  |
| MVIC317                     | <ul style="list-style-type: none"> <li><input type="checkbox"/> ISIN field</li> <li><input type="checkbox"/> Intended Settlement Date field</li> <li><input type="checkbox"/> Securities Account Number field</li> <li><input type="checkbox"/> Securities Movement Type Code field</li> <li><input type="checkbox"/> Submit button</li> </ul>   | The ISIN Code of the delivering Settlement Instruction is not eligible for settlement in the delivering Issuance Account.      | The delivering Issuance Account in a delivering Settlement Instruction must be eligible for settlement in the CSD of the delivering Issuance Account, which must also be the issuer CSD for the ISIN Code specified in the instruction, on the Intended Settlement Date and additionally on the current Business Day if the Intended Settlement Date is in the past. |

| Reference for error message | Field or Button  | Error Text   | Description  |
|-----------------------------|--|--|--|
| MVIC318                     | <ul style="list-style-type: none"> <li><input type="checkbox"/> ISIN field</li> <li><input type="checkbox"/> Intended Settlement Date field</li> <li><input type="checkbox"/> Securities Account Number field</li> <li><input type="checkbox"/> Securities Movement Type Code field</li> <li><input type="checkbox"/> Submit button</li> </ul>   | The ISIN Code of the receiving Settlement Instruction is not eligible for settlement in the receiving Issuance Account.        | The receiving Issuance Account in a receiving Settlement Instruction must be eligible for settlement in the CSD of the receiving Issuance Account, which must also be the issuer CSD for the ISIN Code specified in the instruction, on the Intended Settlement Date and additionally on the current Business Day if the Intended Settlement Date is in the past.          |
| MVIC319                     | <ul style="list-style-type: none"> <li><input type="checkbox"/> ISIN field</li> <li><input type="checkbox"/> Intended Settlement Date field</li> <li><input type="checkbox"/> Securities Account Number field</li> <li><input type="checkbox"/> Submit button</li> <li><input type="checkbox"/> Externally Matched field</li> <li><input type="checkbox"/> Securities Account field</li> </ul> | The ISIN Code of the already matched Settlement Instruction is not eligible for settlement in the delivering Issuance Account. | The delivering Issuance Account in an already matched Settlement Instruction must be eligible for settlement in the CSD of the delivering Issuance Account, which must also be the issuer CSD for the ISIN Code specified in the instruction, on the Intended Settlement Date and additionally on the current Business Day if the Intended Settlement Date is in the past. |
| MVIC320                     | <ul style="list-style-type: none"> <li><input type="checkbox"/> ISIN field</li> <li><input type="checkbox"/> Intended Settlement Date field</li> </ul>   | The ISIN Code of the already matched Settlement Instruc-   | The receiving Issuance Account in an already matched Set-  |

| Reference for error message | Field or Button  | Error Text  | Description   |
|-----------------------------|--|---|---|
|                             | <ul style="list-style-type: none"> <li><input type="checkbox"/> Securities Account Number field</li> <li><input type="checkbox"/> Submit button</li> <li><input type="checkbox"/> Securities Account field</li> <li><input type="checkbox"/> Externally Matched field</li> </ul>   | <p>tion is not eligible for settlement in the receiving Issuance Account.</p>   | <p>tlement Instruction must be eligible for settlement in the CSD of the receiving Issuance Account, which must also be the issuer CSD for the ISIN Code specified in the instruction, on the Intended Settlement Date and additionally on the current Business Day if the Intended Settlement Date is in the past.</p> |
| MVCA517                     | <ul style="list-style-type: none"> <li><input type="checkbox"/> Debit Credit Indicator field</li> <li><input type="checkbox"/> T2S Dedicated Cash Account Number field</li> <li><input type="checkbox"/> Intended Settlement Date field</li> <li><input type="checkbox"/> Payment Type Code field</li> <li><input type="checkbox"/> Submit button</li> </ul> | <p>The Debtor Party BIC stated in the Settlement Instruction is not the same as the Account Owner BIC of the debited T2S Dedicated Cash Account on the settlement date.</p> | <p>The Debtor Party BIC stated in a Settlement Instruction that debits cash must be the Party BIC of the owner of the debited T2S Dedicated Cash Account on the Intended Settlement Date and additionally on the current Business Day if the Intended Settlement Date is in the past.</p>                               |
| MVCA518                     | <ul style="list-style-type: none"> <li><input type="checkbox"/> Debit Credit Indicator field</li> <li><input type="checkbox"/> T2S Dedicated Cash Account field</li> <li><input type="checkbox"/> Intended Settlement Date field</li> </ul>  | <p>The Creditor Party BIC stated in the Settlement Instruction is not the same as the Account Owner BIC of the credited T2S Dedic-</p>                                      | <p>The Creditor Party BIC stated in a Settlement Instruction that credits cash must be the Party BIC of the owner of the credited T2S Dedicated Cash Account on the Intended Settlement Date and</p>  |

| Reference for error message | Field or Button  | Error Text  | Description   |
|-----------------------------|--|---|---|
|                             | <input type="checkbox"/> Payment Type Code field<br><input type="checkbox"/> Submit button   | ated Cash Account on the settlement date.   | additionally on the current Business Day if the Intended Settlement Date is in the past.  |
| MVCP092                     | <input type="checkbox"/> Party Hold field<br><input type="checkbox"/> Submit button  | The sender of a Settlement Instruction with a Party Hold activated is not authorised to send a Settlement Instruction with Party Hold on behalf of an external CSD. | If the relevant Depository is an external CSD, the sender of a Settlement Instruction with a Party Hold activated must be authorised to send a Settlement Instruction with Party Hold on behalf of that external CSD. |
| MVCP102                     | <input type="checkbox"/> Delivering Depository BIC field<br><input type="checkbox"/> Submit button   | The Delivering Depository informed in a Settlement Instruction does not exist in T2S.   | The Delivering Depository informed in a Settlement Instruction must exist in T2S.   |
| MVCP103                     | <input type="checkbox"/> Receiving Depository BIC field<br><input type="checkbox"/> Submit button  | The Receiving Depository informed in a Settlement Instruction does not exist in T2S.  | The Receiving Depository informed in a Settlement Instruction must exist in T2S.  |
| MVCP124                     | <input type="checkbox"/> Party Hold field<br><input type="checkbox"/> External Matched field<br><input type="checkbox"/> Securities Account field<br><input type="checkbox"/> Securities Account field<br><input type="checkbox"/> Submit button | The sender of a Settlement Instruction is not authorised to perform a Party Hold on the Securities Account of the counterparty.                                     | The sender of an already matched Settlement Instruction with Party Hold activated must be authorised to perform a Party Hold on the Securities Account of the counterparty.   |

| Reference for error message | Field or Button   | Error Text  | Description  |
|-----------------------------|---|---|--|
| MVCP125                     | <input type="checkbox"/> Party Hold field<br><input type="checkbox"/> External Matched field<br><input type="checkbox"/> Securities Account field<br><input type="checkbox"/> Securities Account field<br><input type="checkbox"/> Submit button            | The sender of a Settlement Instruction is not authorised to perform a Party Hold on behalf of the external CSD of the counterparty.                 | If the Depository of the counterpart is an external CSD, the sender of an already matched Settlement Instruction with Party Hold activated must be authorised to perform a Party Hold on behalf of that external CSD.                |
| MVCP126                     | <input type="checkbox"/> CSD Hold field<br><input type="checkbox"/> External Matched field<br><input type="checkbox"/> Securities Account field<br><input type="checkbox"/> Securities Account field<br><input type="checkbox"/> Submit button              | The sender of a Settlement Instruction is not authorised to perform a CSD Hold on the Securities Account of the counterparty.                       | The sender of an already matched Settlement Instruction with CSD Hold activated must be authorised to perform a CSD Hold on the Securities Account of the counterparty.  |
| MVCP127                     | <input type="checkbox"/> CSD Hold field<br><input type="checkbox"/> External Matched field<br><input type="checkbox"/> Receiving Depository BIC field<br><input type="checkbox"/> Delivering Depository BIC field<br><input type="checkbox"/> Submit button | The sender of a Settlement Instruction is not authorised to perform a CSD Hold on behalf of the parent CSD of the external CSD of the counterparty. | If the Depository of the counterpart is an external CSD, the sender of an already matched Settlement Instruction with a CSD Hold activated must be authorised to perform a CSD Hold on behalf of the parent CSD of the external CSD. |
| MVCP119                     | <input type="checkbox"/> Instructing Party BIC field<br><input type="checkbox"/> Instructing Party Parent BIC field<br><input type="checkbox"/> Submit button   | The sender of a Settlement Instruction is not authorised to send a Settlement Instruction using this Instructing Party.                             | If the sender of a Settlement Instruction does not belong to the Instructing Party, then the sender of a Settlement Instruction must   |

| Reference for error message | Field or Button   | Error Text  | Description  |
|-----------------------------|---|---|--|
|                             |   |   | be authorised to send a Settlement Instruction using the Instructing Party.  |
| MVDC024                     | <input type="checkbox"/> Instructing Party BIC field  | The Instructing Party specified in a Settlement Instruction must exist in T2S Static Data.  | The Instructing Party specified in the Settlement Instruction does not exist in T2S Static Data.   |
| MVCP110                     | <input type="checkbox"/> External Matched field<br><input type="checkbox"/> Submit button   | The sender of an already matched Settlement Instruction is not authorised to send a Settlement Instruction on behalf of the external CSD of the counterparty. | If the Depository of the counterpart is an external CSD, the sender of an already matched Settlement Instruction must be authorised to send a Settlement Instruction on behalf of that external CSD. |
| MVCP099                     | <input type="checkbox"/> Reference Type field<br><input type="checkbox"/> Reference field<br><input type="checkbox"/> Submit button | The Reference Owner of the Linked Instruction does not belong to the CSD (parent CSD in case of an external CSD) or NCB of the Instructing Party.             | If a T2S actor wants to make use of linkages across several instructions sent to T2S via different CSDs or NCBs he holds accounts with, the T2S actor has to make use of the T2S reference.          |
| MVLI869                     | <input type="checkbox"/> Reference field<br><input type="checkbox"/> Submit button  | The Linked Instruction, referenced by a T2S Instruction Reference, does not exist.  | If the reference indicated in the linkage section is the T2S Instruction Reference, then the referenced  |



| Reference for error message | Field or Button  | Error Text   | Description  |
|-----------------------------|--|--|--|
|                             |  |  | Settlement Instruction or Settlement Restriction must exist in T2S.  |
| MVLI872                     | <input type="checkbox"/> Link Type field<br><input type="checkbox"/> Reference field<br><input type="checkbox"/> Submit button | The Processing Position must be specified.   | If a Settlement Instruction specifies a link with another instruction using a T2S Actor Instruction Reference or a T2S Instruction Reference , the Processing Position must be specified |
| MVLI875                     | <input type="checkbox"/> Link Type field<br><input type="checkbox"/> Submit button   | The instruction cannot be linked to a Pool with a Processing Position with AFTER or BEFORE.                                  | If a Settlement Instruction specifies a link to a Pool , if the Processing Position for this link is specified, it only can be WITH  |
| MVCP052                     | <input type="checkbox"/> Securities Transaction Type field<br><input type="checkbox"/> Submit button                           | The sender of the Settlement Instruction is not authorised to send a Settlement Instruction using this ISO Transaction Code. | The sender of a Settlement Instruction must be authorised to send a Settlement Instruction using the ISO Transaction Code CNCB.  |
| MVCP053                     | <input type="checkbox"/> Securities Transaction Type field<br><input type="checkbox"/> Submit button                           | The sender of the Settlement Instruction is not authorised to send a Settlement Instruction using this ISO Transaction Code. | The sender of a Settlement Instruction must be authorised to send a Settlement Instruction using the ISO Transaction Code BSBK.  |
| MVCP054                     | <input type="checkbox"/> Securities Transaction Type field<br><input type="checkbox"/> Submit button                           | The sender of the Settlement Instruction is not authorised to send a Settlement  | The sender of a Settlement Instruction must be authorised to send a Settlement In-   |

| Reference for error message | Field or Button  | Error Text   | Description   |
|-----------------------------|--|--|---|
|                             |  | Instruction using this ISO Transaction Code.   | struction using the ISO Transaction Code COLI.  |
| MVCP055                     | <input type="checkbox"/> Securities Transaction Type field<br><input type="checkbox"/> Submit button | The sender of the Settlement Instruction is not authorised to send a Settlement Instruction using this ISO Transaction Code. | The sender of a Settlement Instruction must be authorised to send a Settlement Instruction using the ISO Transaction Code COLO. |
| MVCP056                     | <input type="checkbox"/> Securities Transaction Type field<br><input type="checkbox"/> Submit button | The sender of the Settlement Instruction is not authorised to send a Settlement Instruction using this ISO Transaction Code. | The sender of a Settlement Instruction must be authorised to send a Settlement Instruction using the ISO Transaction Code CONV. |
| MVCP057                     | <input type="checkbox"/> Securities Transaction Type field<br><input type="checkbox"/> Submit button | The sender of the Settlement Instruction is not authorised to send a Settlement Instruction using this ISO Transaction Code. | The sender of a Settlement Instruction must be authorised to send a Settlement Instruction using the ISO Transaction Code FCTA. |
| MVCP058                     | <input type="checkbox"/> Securities Transaction Type field<br><input type="checkbox"/> Submit button | The sender of the Settlement Instruction is not authorised to send a Settlement Instruction using this ISO Transaction Code. | The sender of a Settlement Instruction must be authorised to send a Settlement Instruction using the ISO Transaction Code INSP. |
| MVCP059                     | <input type="checkbox"/> Securities Transaction Type field<br><input type="checkbox"/> Submit button | The sender of the Settlement Instruction is not authorised to send a Settlement  | The sender of a Settlement Instruction must be authorised to send a Settlement In-  |

| Reference for error message | Field or Button  | Error Text   | Description   |
|-----------------------------|--|--|---|
|                             |  | Instruction using this ISO Transaction Code.   | struction using the ISO Transaction Code ISSU.  |
| MVCP060                     | <input type="checkbox"/> Securities Transaction Type field<br><input type="checkbox"/> Submit button | The sender of the Settlement Instruction is not authorised to send a Settlement Instruction using this ISO Transaction Code. | The sender of a Settlement Instruction must be authorised to send a Settlement Instruction using the ISO Transaction Code MKDW. |
| MVCP061                     | <input type="checkbox"/> Securities Transaction Type field<br><input type="checkbox"/> Submit button | The sender of the Settlement Instruction is not authorised to send a Settlement Instruction using this ISO Transaction Code. | The sender of a Settlement Instruction must be authorised to send a Settlement Instruction using the ISO Transaction Code MKUP. |
| MVCP062                     | <input type="checkbox"/> Securities Transaction Type field<br><input type="checkbox"/> Submit button | The sender of the Settlement Instruction is not authorised to send a Settlement Instruction using this ISO Transaction Code. | The sender of a Settlement Instruction must be authorised to send a Settlement Instruction using the ISO Transaction Code NETT. |
| MVCP063                     | <input type="checkbox"/> Securities Transaction Type field<br><input type="checkbox"/> Submit button | The sender of the Settlement Instruction is not authorised to send a Settlement Instruction using this ISO Transaction Code. | The sender of a Settlement Instruction must be authorised to send a Settlement Instruction using the ISO Transaction Code NSYN. |
| MVCP064                     | <input type="checkbox"/> Securities Transaction Type field<br><input type="checkbox"/> Submit button | The sender of the Settlement Instruction is not authorised to send a Settlement  | The sender of a Settlement Instruction must be authorised to send a Settlement In-  |

| Reference for error message | Field or Button  | Error Text   | Description   |
|-----------------------------|--|--|---|
|                             |  | Instruction using this ISO Transaction Code.   | struction using the ISO Transaction Code OWNE.  |
| MVCP065                     | <input type="checkbox"/> Securities Transaction Type field<br><input type="checkbox"/> Submit button | The sender of the Settlement Instruction is not authorised to send a Settlement Instruction using this ISO Transaction Code. | The sender of a Settlement Instruction must be authorised to send a Settlement Instruction using the ISO Transaction Code OWNI. |
| MVCP066                     | <input type="checkbox"/> Securities Transaction Type field<br><input type="checkbox"/> Submit button | The sender of the Settlement Instruction is not authorised to send a Settlement Instruction using this ISO Transaction Code. | The sender of a Settlement Instruction must be authorised to send a Settlement Instruction using the ISO Transaction Code PAIR. |
| MVCP067                     | <input type="checkbox"/> Securities Transaction Type field<br><input type="checkbox"/> Submit button | The sender of the Settlement Instruction is not authorised to send a Settlement Instruction using this ISO Transaction Code. | The sender of a Settlement Instruction must be authorised to send a Settlement Instruction using the ISO Transaction Code PLAC. |
| MVCP068                     | <input type="checkbox"/> Securities Transaction Type field<br><input type="checkbox"/> Submit button | The sender of the Settlement Instruction is not authorised to send a Settlement Instruction using this ISO Transaction Code. | The sender of a Settlement Instruction must be authorised to send a Settlement Instruction using the ISO Transaction Code PORT. |
| MVCP069                     | <input type="checkbox"/> Securities Transaction Type field<br><input type="checkbox"/> Submit button | The sender of the Settlement Instruction is not authorised to send a Settlement  | The sender of a Settlement Instruction must be authorised to send a Settlement In-  |

| Reference for error message | Field or Button  | Error Text   | Description   |
|-----------------------------|--|--|---|
|                             |  | Instruction using this ISO Transaction Code.   | struction using the ISO Transaction Code REAL.  |
| MVCP070                     | <input type="checkbox"/> Securities Transaction Type field<br><input type="checkbox"/> Submit button | The sender of the Settlement Instruction is not authorised to send a Settlement Instruction using this ISO Transaction Code. | The sender of a Settlement Instruction must be authorised to send a Settlement Instruction using the ISO Transaction Code REDI. |
| MVCP071                     | <input type="checkbox"/> Securities Transaction Type field<br><input type="checkbox"/> Submit button | The sender of the Settlement Instruction is not authorised to send a Settlement Instruction using this ISO Transaction Code. | The sender of a Settlement Instruction must be authorised to send a Settlement Instruction using the ISO Transaction Code REDM. |
| MVCP072                     | <input type="checkbox"/> Securities Transaction Type field<br><input type="checkbox"/> Submit button | The sender of the Settlement Instruction is not authorised to send a Settlement Instruction using this ISO Transaction Code. | The sender of a Settlement Instruction must be authorised to send a Settlement Instruction using the ISO Transaction Code RELE. |
| MVCP073                     | <input type="checkbox"/> Securities Transaction Type field<br><input type="checkbox"/> Submit button | The sender of the Settlement Instruction is not authorised to send a Settlement Instruction using this ISO Transaction Code. | The sender of a Settlement Instruction must be authorised to send a Settlement Instruction using the ISO Transaction Code REPU. |
| MVCP074                     | <input type="checkbox"/> Securities Transaction Type field<br><input type="checkbox"/> Submit button | The sender of the Settlement Instruction is not authorised to send a Settlement  | The sender of a Settlement Instruction must be authorised to send a Settlement In-  |

| Reference for error message | Field or Button  | Error Text   | Description   |
|-----------------------------|--|--|---|
|                             |  | Instruction using this ISO Transaction Code.   | struction using the ISO Transaction Code RODE.  |
| MVCP075                     | <input type="checkbox"/> Securities Transaction Type field<br><input type="checkbox"/> Submit button | The sender of the Settlement Instruction is not authorised to send a Settlement Instruction using this ISO Transaction Code. | The sender of a Settlement Instruction must be authorised to send a Settlement Instruction using the ISO Transaction Code RPTO. |
| MVCP076                     | <input type="checkbox"/> Securities Transaction Type field<br><input type="checkbox"/> Submit button | The sender of the Settlement Instruction is not authorised to send a Settlement Instruction using this ISO Transaction Code. | The sender of a Settlement Instruction must be authorised to send a Settlement Instruction using the ISO Transaction Code RVPO. |
| MVCP077                     | <input type="checkbox"/> Securities Transaction Type field<br><input type="checkbox"/> Submit button | The sender of the Settlement Instruction is not authorised to send a Settlement Instruction using this ISO Transaction Code. | The sender of a Settlement Instruction must be authorised to send a Settlement Instruction using the ISO Transaction Code SBBK. |
| MVCP078                     | <input type="checkbox"/> Securities Transaction Type field<br><input type="checkbox"/> Submit button | The sender of the Settlement Instruction is not authorised to send a Settlement Instruction using this ISO Transaction Code. | The sender of a Settlement Instruction must be authorised to send a Settlement Instruction using the ISO Transaction Code SBRE. |
| MVCP079                     | <input type="checkbox"/> Securities Transaction Type field<br><input type="checkbox"/> Submit button | The sender of the Settlement Instruction is not authorised to send a Settlement  | The sender of a Settlement Instruction must be authorised to send a Settlement In-  |

| Reference for error message | Field or Button  | Error Text   | Description   |
|-----------------------------|--|--|---|
|                             |  | Instruction using this ISO Transaction Code.   | struction using the ISO Transaction Code SECB.  |
| MVCP080                     | <input type="checkbox"/> Securities Transaction Type field<br><input type="checkbox"/> Submit button | The sender of the Settlement Instruction is not authorised to send a Settlement Instruction using this ISO Transaction Code. | The sender of a Settlement Instruction must be authorised to send a Settlement Instruction using the ISO Transaction Code SECL. |
| MVCP081                     | <input type="checkbox"/> Securities Transaction Type field<br><input type="checkbox"/> Submit button | The sender of the Settlement Instruction is not authorised to send a Settlement Instruction using this ISO Transaction Code. | The sender of a Settlement Instruction must be authorised to send a Settlement Instruction using the ISO Transaction Code SLRE. |
| MVCP082                     | <input type="checkbox"/> Securities Transaction Type field<br><input type="checkbox"/> Submit button | The sender of the Settlement Instruction is not authorised to send a Settlement Instruction using this ISO Transaction Code. | The sender of a Settlement Instruction must be authorised to send a Settlement Instruction using the ISO Transaction Code SUBS. |
| MVCP083                     | <input type="checkbox"/> Securities Transaction Type field<br><input type="checkbox"/> Submit button | The sender of the Settlement Instruction is not authorised to send a Settlement Instruction using this ISO Transaction Code. | The sender of a Settlement Instruction must be authorised to send a Settlement Instruction using the ISO Transaction Code SYND. |
| MVCP084                     | <input type="checkbox"/> Securities Transaction Type field<br><input type="checkbox"/> Submit button | The sender of the Settlement Instruction is not authorised to send a Settlement  | The sender of a Settlement Instruction must be authorised to send a Settlement In-  |

| Reference for error message | Field or Button  | Error Text   | Description   |
|-----------------------------|--|--|---|
|                             |  | Instruction using this ISO Transaction Code.   | struction using the ISO Transaction Code TBAC.  |
| MVCP085                     | <input type="checkbox"/> Securities Transaction Type field<br><input type="checkbox"/> Submit button | The sender of the Settlement Instruction is not authorised to send a Settlement Instruction using this ISO Transaction Code. | The sender of a Settlement Instruction must be authorised to send a Settlement Instruction using the ISO Transaction Code TRAD. |
| MVCP086                     | <input type="checkbox"/> Securities Transaction Type field<br><input type="checkbox"/> Submit button | The sender of the Settlement Instruction is not authorised to send a Settlement Instruction using this ISO Transaction Code. | The sender of a Settlement Instruction must be authorised to send a Settlement Instruction using the ISO Transaction Code TRPO. |
| MVCP087                     | <input type="checkbox"/> Securities Transaction Type field<br><input type="checkbox"/> Submit button | The sender of the Settlement Instruction is not authorised to send a Settlement Instruction using this ISO Transaction Code. | The sender of a Settlement Instruction must be authorised to send a Settlement Instruction using the ISO Transaction Code TRVO. |
| MVCP088                     | <input type="checkbox"/> Securities Transaction Type field<br><input type="checkbox"/> Submit button | The sender of the Settlement Instruction is not authorised to send a Settlement Instruction using this ISO Transaction Code. | The sender of a Settlement Instruction must be authorised to send a Settlement Instruction using the ISO Transaction Code TURN. |
| MVCP089                     | <input type="checkbox"/> Securities Transaction Type field<br><input type="checkbox"/> Submit button | The sender of the Settlement Instruction is not authorised to send a Settlement  | The sender of a Settlement Instruction must be authorised to send a Settlement In-  |



| Reference for error message | Field or Button  | Error Text   | Description   |
|-----------------------------|--|--|---|
|                             |  | Instruction using this ISO Transaction Code.   | struction using the ISO Transaction Code CORP.  |
| MVCP090                     | <input type="checkbox"/> Securities Transaction Type field<br><input type="checkbox"/> Submit button | The sender of the Settlement Instruction is not authorised to send a Settlement Instruction using this ISO Transaction Code. | The sender of a Settlement Instruction must be authorised to send a Settlement Instruction using the ISO Transaction Code CLAI. |
| MVCP091                     | <input type="checkbox"/> Securities Transaction Type field<br><input type="checkbox"/> Submit button | The sender of the Settlement Instruction is not authorised to send a Settlement Instruction using this ISO Transaction Code. | The sender of a Settlement Instruction must be authorised to send a Settlement Instruction using the ISO Transaction Code AUTO. |
| MVCP128                     | <input type="checkbox"/> Securities Transaction Type field<br><input type="checkbox"/> Submit button | The sender of the Settlement Instruction is not authorised to send a Settlement Instruction using this ISO Transaction Code. | The sender of a Settlement Instruction must be authorised to send a Settlement Instruction using the ISO Transaction Code ETFT. |
| MVCP130                     | <input type="checkbox"/> Securities Transaction Type field<br><input type="checkbox"/> Submit button | The sender of the Settlement Instruction is not authorised to send a Settlement Instruction using this ISO Transaction Code. | The sender of a Settlement Instruction must be authorised to send a Settlement Instruction using the ISO Transaction Code BYIY. |
| MVCP131                     | <input type="checkbox"/> Securities Transaction Type field<br><input type="checkbox"/> Submit button | The sender of the Settlement Instruction is not authorised to send a Settlement  | The sender of a Settlement Instruction must be authorised to send a Settlement In-  |

| Reference for error message | Field or Button  | Error Text  | Description   |
|-----------------------------|--|---|---|
|                             |  | Instruction using this ISO Transaction Code.  | struction using the ISO Transaction Code SWIF   |
| MVCP132                     | <input type="checkbox"/> Securities Transaction Type field<br><input type="checkbox"/> Submit button                               | The sender of the Settlement Instruction is not authorised to send a Settlement Instruction using this ISO Transaction Code.  | The sender of a Settlement Instruction must be authorised to send a Settlement Instruction using the ISO Transaction Code SWIT  |
| MVSR612                     | <input type="checkbox"/> Settlement Quantity<br><input type="checkbox"/> Settlement Type<br><input type="checkbox"/> Submit button | The number of decimals of the Settlement Quantity of the Settlement Instruction is greater than the number of decimals of the Settlement Multiple of the related security | The number of decimals of the Settlement Quantity of a Settlement Instruction <b>with exchange on of</b> Securities must be equal or lower than the number of decimals of the Settlement Unit Multiple of the related Security. <b>{CR-847}</b> |
| MVSR701                     | <input type="checkbox"/> Transaction Identification field<br><input type="checkbox"/> Submit button                                |   | A Settlement Instruction that fulfils a specific restriction configured by its System Entity with positive Restriction Processing Type 'CSD Validation Hold' is accepted, and its CSD Validation Hold Status is set to 'Yes'.                   |
| MVSR702                     | <input type="checkbox"/> Transaction Identification field<br><input type="checkbox"/> Submit button                                |   | A Settlement Instruction that fulfils a specific restriction configured by its System Entity with negative  |

| Reference for error message | Field or Button   | Error Text  | Description  |
|-----------------------------|---|---|--|
|                             |   |   | Restriction Processing Type 'CSD Validation Hold' is accepted, and its CSD Validation Hold Status is set to 'No'.  |
| MVSR703                     | <input type="checkbox"/> Transaction Identification field<br><input type="checkbox"/> Submit button | Settlement Instruction rejected due to a Restriction Type.  | A new Settlement Instruction that fulfils a specific restriction configured by its System Entity with positive Restriction Processing Type 'Rejection' is rejected.                |
| MVSR704                     | <input type="checkbox"/> Transaction Identification field<br><input type="checkbox"/> Submit button |   | A Settlement Instruction that fulfils a specific restriction configured by its System Entity with negative Restriction Processing Type 'Rejection' is not rejected nor cancelled.  |
| MVSR707                     | <input type="checkbox"/> Transaction Identification field<br><input type="checkbox"/> Submit button | Settlement Instruction cancelled due to a Restriction Type. | An already existing Settlement Instruction that fulfils a specific restriction configured by its System Entity with positive Restriction Processing Type 'Rejection' is cancelled. |

### 5.4.2.83 Settlement Instructions - Search/List Screen

△ [▶ 176]

| Reference for error message | Field or Button  | Error Text   | Description  |
|-----------------------------|--|--|--|
| QMPC005                     | <input type="checkbox"/> Settlement Amount field<br><input type="checkbox"/> Search button   | The lower limit of the Cash Amount range is more than the upper limit of the Cash Amount range.                    | In case the Cash Amount is stated as a range, the lower limit of the Cash Amount range must be less than the upper limit of the Cash Amount range.   |
| QMPC006                     | <input type="checkbox"/> Quantity/Nominal field<br><input type="checkbox"/> Search button  | The lower limit of the Securities Quantity range is greater than the upper limit of the Securities Quantity range. | In case the Securities Quantity is stated as a range, the lower limit of the Securities Quantity range must be less than the upper limit of the Securities Quantity range.   |
| QMPC007                     | <input type="checkbox"/> Trade Date field<br><input type="checkbox"/> Search button  | The Trade Date From is later than the Trade Date To.   | In case the Trade Date is stated as a range, the Trade Date From must be before the Trade Date To, i.e. earlier or on the same day as the Trade Date To.   |
| QMPC010                     | <input type="checkbox"/> Trade Date field<br><input type="checkbox"/> Intended Settlement Date field<br><input type="checkbox"/> Search button | The Trade Date From is after the Intended Settlement Date From.  | In case the Trade Date and the Intended Settlement Date are specified, the Trade Date From must not be after the Intended Settlement Date From, i.e. it must be earlier or on the same day as the Intended Settlement Date From. |
| QMPC011                     | <input type="checkbox"/> Trade Date field<br><input type="checkbox"/> Actual Settlement Date field<br><input type="checkbox"/> Search button   | The Trade Date From is after the Actual Settlement Date From.  | In case the Trade Date and the Actual Settlement Date are specified, the Trade Date  |

| Reference for error message | Field or Button  | Error Text   | Description  |
|-----------------------------|--|--|--|
|                             |  |  | From must not be after the Actual Settlement Date From, i.e. it must be earlier or on the same day as the Actual Settlement Date From.   |
| QMPC012                     | <input type="checkbox"/> Intended Settlement Date field<br><input type="checkbox"/> Search button        | The Intended Settlement Date From is after the Intended Settlement Date To.    | In case the Intended Settlement Date is stated as a range, the Intended Settlement Date From must be before the Intended Settlement Date To, i.e. earlier or on the same day as the Intended Settlement Date To. |
| QMPC013                     | <input type="checkbox"/> Actual Settlement Date and Time field<br><input type="checkbox"/> Search button | The requested Actual Settlement Date From is older than three calendar months. | The requested Actual Settlement Date From must not be older than three calendar months.  |
| QMPC014                     | <input type="checkbox"/> Actual Settlement Date and Time field<br><input type="checkbox"/> Search button | The Actual Settlement Date From is after the Actual Settlement Date To.        | In case the Actual Settlement Date is stated as a range, the Actual Settlement Date From must be before the Actual Settlement Date To, i.e. earlier or on the same day as the Actual Settlement Date To.         |
| QMPC018                     | <input type="checkbox"/> ISIN field<br><input type="checkbox"/> Search button                            | The specified ISIN is not known in T2S.  | In case an ISIN is specified, it has to be known in T2S.   |
| QMPC030                     | <input type="checkbox"/> Securities Account Number field<br><input type="checkbox"/> Search button       | The specified Securities Account Number is not known in T2S.                   | In case a Securities Account Number is specified, it has to be known in T2S.   |

| Reference for error message | Field or Button  | Error Text   | Description  |
|-----------------------------|--|--|--|
| QMPC031                     | <input type="checkbox"/> T2S Dedicated Cash Account Number field<br><input type="checkbox"/> Search button | The specified T2S Dedicated Cash Account Number is not known in T2S. | In case a T2S Dedicated Cash Account Number is specified, it has to be known in T2S. |
| QMPC032                     | <input type="checkbox"/> Instructing Party BIC field<br><input type="checkbox"/> Search button             | The specified Party BIC is not known in T2S.                         | In case a Party BIC is specified, it has to be known in T2S.                         |
| QMPC048                     | <input type="checkbox"/> Instructing Party Parent BIC field  | The specified Parent BIC is not known in T2S.                        | In case a Parent BIC is specified, it has to be known in T2S.                        |
| QMPC054                     | <input type="checkbox"/> Settlement Currency field<br><input type="checkbox"/> Search button               | The specified Currency is not known in T2S.                          | In case a Currency is specified, it has to be known in T2S.                          |

#### 5.4.2.84 Status History - Details Screen

△ [▶ 266]

No references for error messages.

#### 5.4.2.85 T2S BIC Directory Items - Search/List Screen

△

| Reference for error message | Field or Button   | Error Text                   | Description  |
|-----------------------------|---|------------------------------|--|
| DRDQ003                     | <input type="checkbox"/> Status field<br><input type="checkbox"/> Valid from field<br><input type="checkbox"/> Valid to field | Data to be updated not found | When performing a T2S BIC Directory deletion request it must refer to an existing and active instance of T2S BIC Directory already closed or with a future Valid From. |
| DRDQ004                     | <input type="checkbox"/> Status field<br><input type="checkbox"/> Valid from field  | Data to be updated not found | When performing a T2S BIC Directory restore request it must refer to   |

| Reference for error message | Field or Button   | Error Text   | Description   |
|-----------------------------|---|--|---|
|                             | <input type="checkbox"/> Valid to field   |  | an existing and deleted instance of T2S BIC Directory already closed or with a future Valid From.   |
| DRDQ005                     | <input type="checkbox"/> Party BIC field<br><input type="checkbox"/> Valid from field<br><input type="checkbox"/> Valid to field  | BIC already assigned   | When performing a T2S BIC Directory restore request it, the pair BIC and BIC Branch Code specified must not be already assigned in the same validity period.    |
| <b>QMPC021</b>              | <input type="checkbox"/> <del>Valid from from field</del><br><input type="checkbox"/> <del>Valid from to field</del><br><input type="checkbox"/> <del>Search button</del> | <del>The From value of the Date From is after the To value of the Date From.</del> | <del>In case the Date From is stated as a range, the From value of the Date From has to be before or equal to the To value of the Date From.</del>              |
| <b>QMPC022</b>              | <input type="checkbox"/> <del>Valid from from field</del><br><input type="checkbox"/> <del>Valid to to field</del><br><input type="checkbox"/> <del>Search button</del>   | <del>The From value of the Date From is after the To value of the Date To.</del>   | <del>In case the Date From and Date To are specified as ranges, the From value of the Date From has to be before or equal to the To value of the Date To.</del> |
| <b>QMPC023</b>              | <input type="checkbox"/> <del>Valid to from field</del><br><input type="checkbox"/> <del>Valid to to field</del><br><input type="checkbox"/> <del>Search button</del>     | <del>The From value of the Date From is after the To value of the Date To.</del>   | <del>In case the To Date is stated as a range, the From value of the Date To has to be before or equal to the To value of the Date To.</del><br><b>{CR-847}</b> |

## 5.4.2.86 T2S DCA Balance - Details Screen

△ [▶ 361]

No references for error messages.

## 5.4.2.87 T2S DCA Balances - Search/List Screen

△ [▶ 357]

| Reference for error message | Field or Button  | Error Text   | Description   |
|-----------------------------|--|--|---|
| QMPC031                     | <input type="checkbox"/> Search button<br><input type="checkbox"/> T2S Dedicated Cash Account Number field   | The specified T2S Dedicated Cash Account Number is not known in T2S.   | In case a T2S Dedicated Cash Account Number is specified, it has to be known in T2S.  |
| QMPC032                     | <input type="checkbox"/> Party BIC field<br><input type="checkbox"/> Search button   | The specified Party BIC is not known in T2S.   | In case a Party BIC is specified, it has to be known in T2S.  |
| QMPC048                     | <input type="checkbox"/> NCB Parent BIC field<br><input type="checkbox"/> Search button  | The specified Parent BIC is not known in T2S.  | In case a Parent BIC is specified, it has to be known in T2S.   |
| QMPC054                     | <input type="checkbox"/> Currency field<br><input type="checkbox"/> Search button  | The specified Currency is not known in T2S.  | In case a Currency is specified, it has to be known in T2S.   |
| QMPC072                     | <input type="checkbox"/> Party BIC field<br><input type="checkbox"/> NCB Parent BIC field<br><input type="checkbox"/> T2S Dedicated Cash Account Number field<br><input type="checkbox"/> Currency field<br><input type="checkbox"/> Search button | The specified combination of T2S Dedicated Cash Account Number, Currency, Account Owner and Account Servicer are not consistent. | In case at least two of the following selection criteria are specified, they have to be consistent, i. e. the T2S Dedicated Cash Account is owned by the specified Party <ul style="list-style-type: none"> <li>• T2S Dedicated Cash Account Number</li> <li>• Account Owner</li> <li>• Account Servicer</li> <li>• Currency, in which the T2S Dedicated Cash Account is issued and/</li> </ul> |



| Reference for error message | Field or Button   | Error Text  | Description   |
|-----------------------------|---|---|---|
|                             |   |   | or in which the Party owns T2SDedicated Cash Accounts   |
| QMPC073                     | <input type="checkbox"/> Date field<br><input type="checkbox"/> Search button   | The specified Date is in the future.                                      | In case a date from is specified, it must not be in the future.   |
| QMPC084                     | <input type="checkbox"/> Party BIC field<br><input type="checkbox"/> NCB Parent BIC field<br><input type="checkbox"/> Search button | The specified Parent BIC is not the System Entity of the specified party. | In case the BIC of a party as well as its parent BIC are specified, a party with these two BICs has to be known in T2S. |
| QMPC091                     | <input type="checkbox"/> Restriction Type field<br><input type="checkbox"/> Search button   | The specified restriction type is not known in T2S.                       | In case a restriction type is specified, it has to be known in T2S.   |

### 5.4.2.88 T2S DCA Postings - Search/List Screen

△ [▶ 363]

| Reference for error message | Field or Button  | Error Text  | Description  |
|-----------------------------|--|---|--|
| QMPC016                     | <input type="checkbox"/> Date field<br><input type="checkbox"/> Search Button  | The Date From is older than three calendar months.                                | The Date From must not be older than three calendar months.  |
| QMPC032                     | <input type="checkbox"/> Party BIC field<br><input type="checkbox"/> Search button   | The specified Party BIC is not known in T2S.                                      | In case a Party BIC is specified, it has to be known in T2S.   |
| QMPC054                     | <input type="checkbox"/> Currency field<br><input type="checkbox"/> Search button  | The specified Currency is not known in T2S.                                       | In case a Currency is specified, it has to be known in T2S.  |
| QMPC072                     | <input type="checkbox"/> Party BIC field<br><input type="checkbox"/> NCB Parent BIC field<br><input type="checkbox"/> T2S Dedicated Cash Account field | The specified combination of T2S Dedicated Cash Account Number, Currency, Account | In case at least two of the following selection criteria are specified, they have to be consistent, i. e. the T2S Dedic- |

| Reference for error message | Field or Button  | Error Text  | Description   |
|-----------------------------|--|---|---|
|                             | <input type="checkbox"/> Currency field<br><input type="checkbox"/> Search button  | Owner and Account Servicer are not consistent.      | ated Cash Account is owned by the specified Party <ul style="list-style-type: none"> <li>• T2S Dedicated Cash Account Number</li> <li>• Account Owner</li> <li>• Account Servicer</li> <li>• Currency, in which the T2S Dedicated Cash Account is issued and/or in which the Party owns T2SDedicated Cash Accounts</li> </ul> |
| QMPC073                     | <input type="checkbox"/> Date field<br><input type="checkbox"/> Date and Time from field<br><input type="checkbox"/> Search button | The specified Date is in the future.                | In case a date from is specified, it must not be in the future.   |
| QMPC091                     | <input type="checkbox"/> Restriction Type field<br><input type="checkbox"/> Search button  | The specified restriction type is not known in T2S. | In case a restriction type is specified, it has to be known in T2S.   |

### 5.4.2.89 Total Amount of Standing/Predefined Liquidity Transfer Orders - Search/List Screen

△ [▶ 400]

| Reference for error message | Field or Button   | Error Text                                    | Description   |
|-----------------------------|---|---|---|
| QMPC032                     | <input type="checkbox"/> Party BIC field<br><input type="checkbox"/> Search button  | The specified Party BIC is not known in T2S.  | In case a Party BIC is specified, it has to be known in T2S.  |
| QMPC048                     | <input type="checkbox"/> Parent BIC field<br><input type="checkbox"/> Search button | The specified Parent BIC is not known in T2S. | In case a Parent BIC is specified, it has to be known in T2S. |

| Reference for error message | Field or Button   | Error Text  | Description   |
|-----------------------------|---|---|---|
| QMPC084                     | <input type="checkbox"/> Parent BIC field<br><input type="checkbox"/> Party BIC field<br><input type="checkbox"/> Search button | The specified Parent BIC is not the System Entity of the specified party. | In case the BIC of a party as well as its parent BIC are specified, a party with these two BICs has to be known in T2S. |

### 5.4.2.90 Total Collateral Value per T2S Dedicated Cash Account - Search/List Screen

△ [▶ 369]

| Reference for error message | Field or Button  | Error Text   | Description  |
|-----------------------------|--|--|--|
| QMPC031                     | <input type="checkbox"/> Search button<br><input type="checkbox"/> T2S Dedicated Cash Account Number field   | The specified T2S Dedicated Cash Account Number is not known in T2S. | In case a T2S Dedicated Cash Account Number is specified, it has to be known in T2S. |
| QMPC032                     | <input type="checkbox"/> Search button<br><input type="checkbox"/> T2S Dedicated Cash Account Owner Party BIC field<br><input type="checkbox"/> NCB Parent BIC field<br><input type="checkbox"/> Securities Account Owner Party BIC field<br><input type="checkbox"/> CSD Parent BIC field | The specified Party BIC is not known in T2S.                         | In case a Party BIC is specified, it has to be known in T2S.                         |
| QMPC054                     | <input type="checkbox"/> Currency field<br><input type="checkbox"/> Search button  | The specified Currency is not known in T2S.                          | In case a Currency is specified, it has to be known in T2S.                          |

| Reference for error message | Field or Button  | Error Text  | Description   |
|-----------------------------|--|---|---|
| QMPC084                     | <input type="checkbox"/> CSD Parent BIC field<br><input type="checkbox"/> Securities Account Owner Party BIC field | The specified Parent BIC is not the System Entity of the specified party. | In case the BIC of a party as well as its parent BIC are specified, a party with these two BICs has to be known in T2S. |

### 5.4.3 References for Error Messages for TMS Screens

#### 5.4.3.1 Trouble Case - Search/List Screen

△ [▶ 786]

| Reference for error message | Field or Button  | Error Text   | Description  |
|-----------------------------|--|--|--|
| ARERR10000                  | <input type="checkbox"/> From field<br><input type="checkbox"/> To field<br><input type="checkbox"/> Search button | Dates into From and To fields are not congruous. Check values! | In case the Date is stated as a range, the Date From has to be before or equal to the Date To. |

#### 5.4.3.2 Trouble Case - Details Screen

△ [▶ 792]

No references for error messages.

#### 5.4.3.3 Trouble Case - Export Screen

△ [▶ 798]

| Reference for error message | Field or Button  | Error Text   | Description  |
|-----------------------------|--|--|--|
| ARERR10000                  | <input type="checkbox"/> From field<br><input type="checkbox"/> To field | Dates into From and To fields are not congruous. Check values! | In case the Date is stated as a range, the Date From has to be before or equal to the Date To. |